

INSTRUCTION MANUAL

AIR 7020

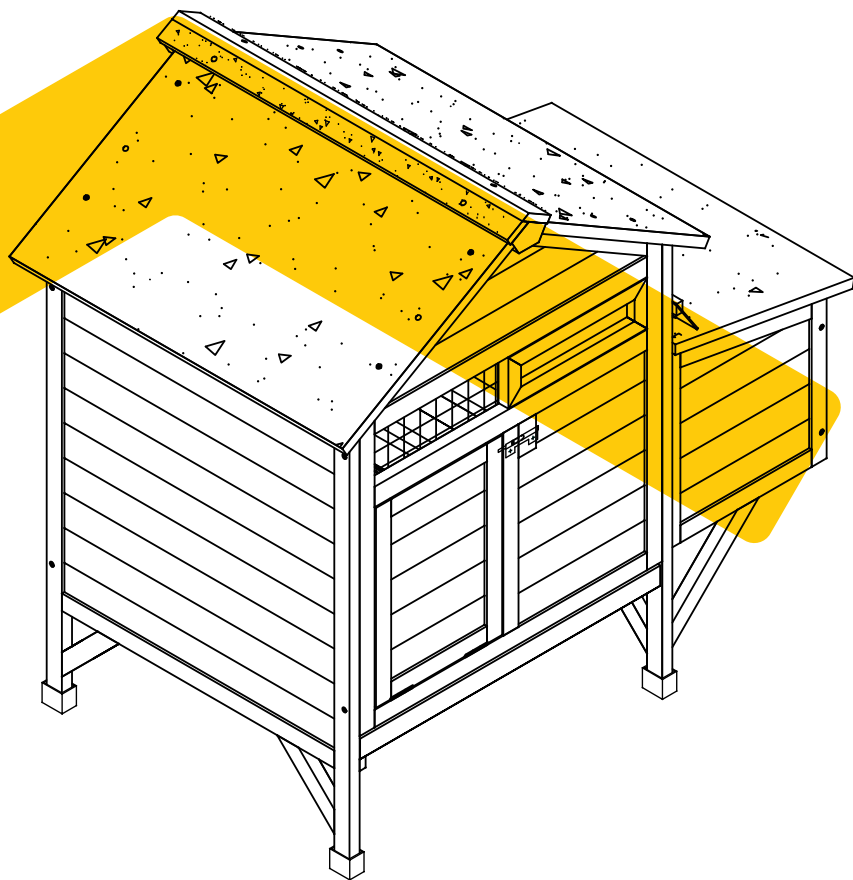



NOTICE

Please retain these instructions for future reference.

- Firmly secure all bolts,screws and knobs before use.
- Reconfirm that all bolts,screws,and knobs are secure every 90 days.
- Fasten screws loosely during initial assembly. Do not fully tighten screws until the item is completely assembled.
- Do not use or store this item in the proximity of open flame or flammable/combustible chemicals.
- Be aware that some parts are heavy and have sharp edges.
- Be aware that moving parts can injure,crush and cut.
- If any parts are missing,broken,damaged,or worn,stop using this product until repairs are made and/or factory replacement parts are installed.
- Do not use this item in a way inconsistent with the manufacturer' s instructions as this could void the product warranty.

TOOLS REQUIRED //



PHILLIPS
SCREWDRIVER

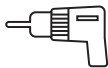

DRILL
(RECOMMENDED)



2PERSON
ASSEMBLY



APPROXIMATELY
45MIN. ASSEMBLY

HARDWARE //

M3.5x50mm SCREW
4PCS+1 spare



P1

M3.5x40mm SCREW
12PCS+1 spare



P2

M3.5x35mm SCREW
8PCS+1spare



P3

M3.5x25mm SCREW
7PCS+1 spare



P4

M3.0x16mm SCREW
8PCS+1 spare



P5

Foot pad
4PCS



P6

M6.0x50mm BOLT
4PCS+1spare



P7

Spring latch
1PC

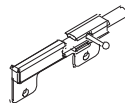

P8

PARTS //

Front panel
1PC

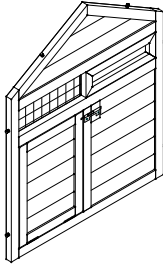

A

Back panel
1PC

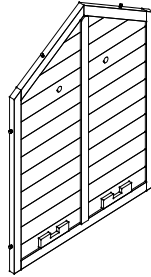

B

Left panel
1PC

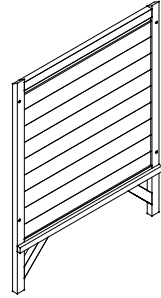

C

Right panel
1PC

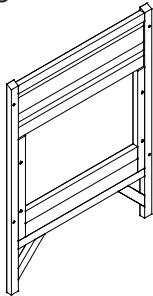

D

Perches
2PCS

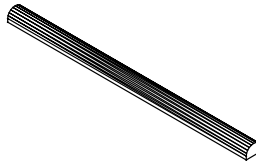

E

Tray
1PC

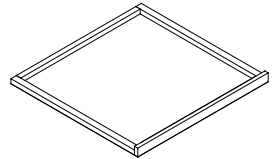

F

Left panel of nesting box
1PC

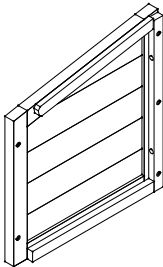

G

Right panel of nesting box
1PC

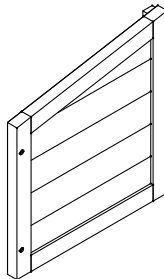

H

Front panel of nesting box
1PC

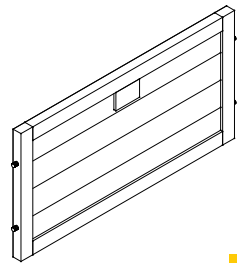

I

PARTS //

Bottom panel of nesting box
1PC

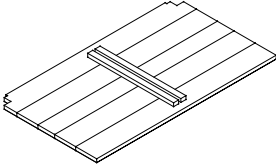

J

Divider panel of nesting box
1PC

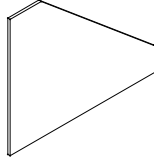

K

Roof of nesting box
1PC

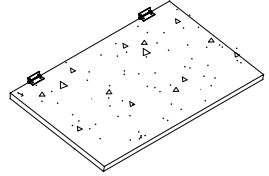

L

PVC waterproof strip of nesting box
1PC

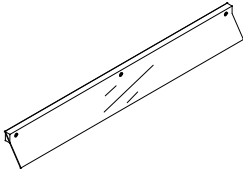

M

Support slats
2PCS

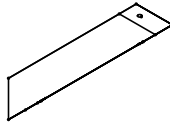

N

Roofs
2PCS

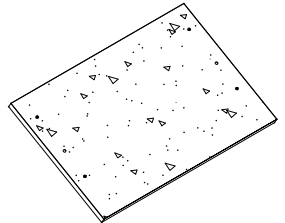

O

Roof cap
1PC

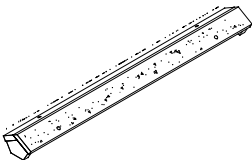

P

PRODUCT ASSEMBLY //

01 Attach the front panel Part A and the back panel Part B to the Part C & D by 8XP2 screws.

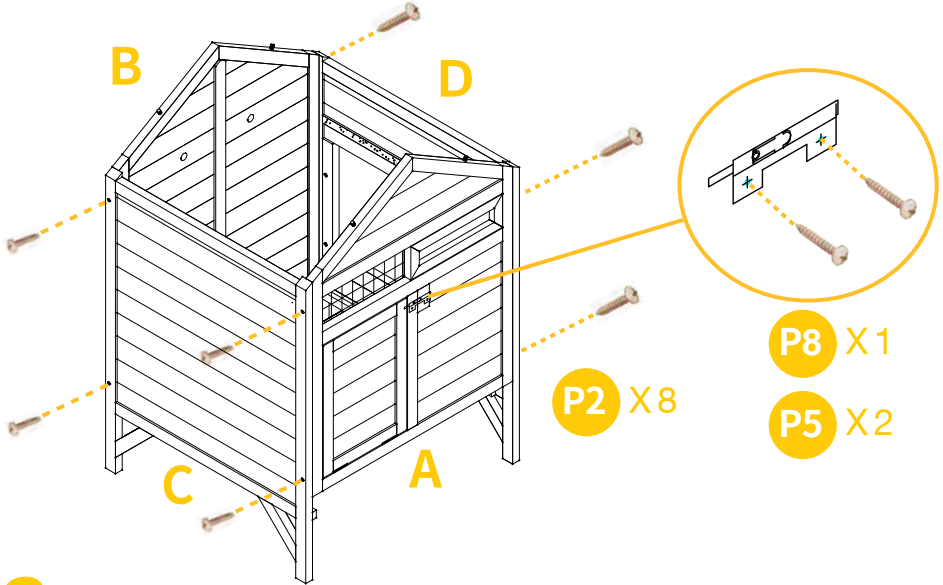

02 Using 4XP6 to stabilize the coop's feet.

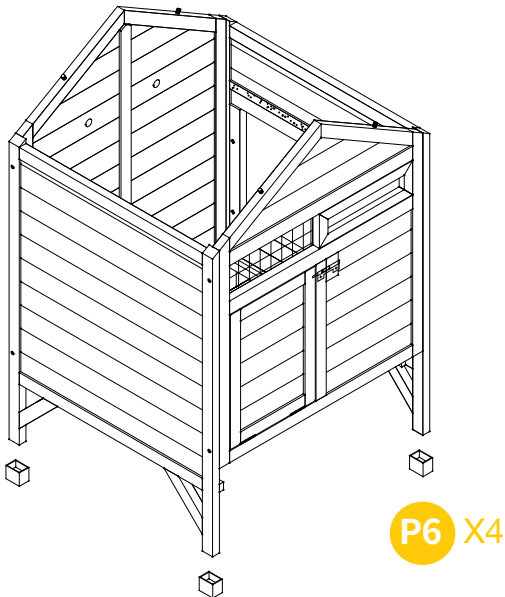

PRODUCT ASSEMBLY //

03

Insert the 2 perches Part E into slots inside Part A & B.
Slide in the tray Part F.

Ex2

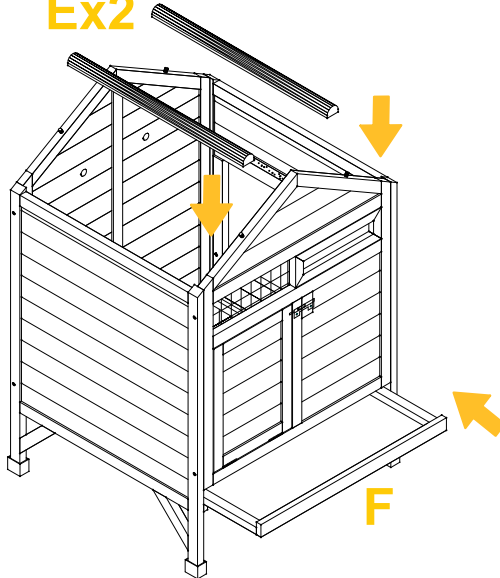

04

Attach the Part G and Part H to the coop by 4XP7 bolts.

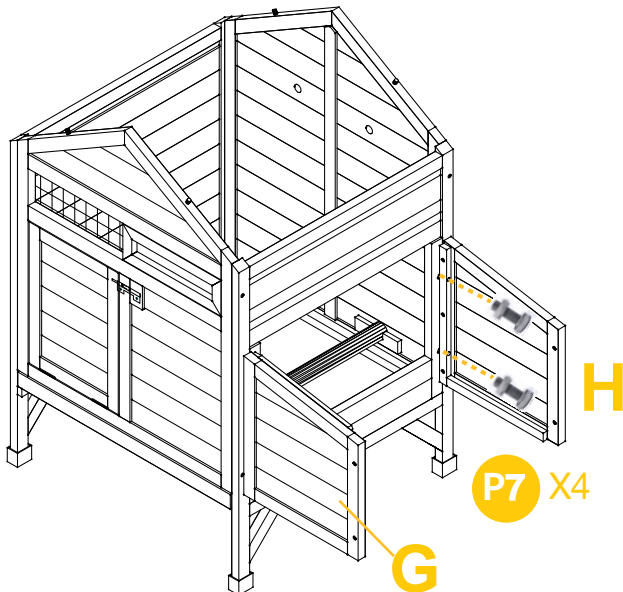

PRODUCT ASSEMBLY //

05

Attach the Part I to the Part G and Part H by 4XP2 screws .

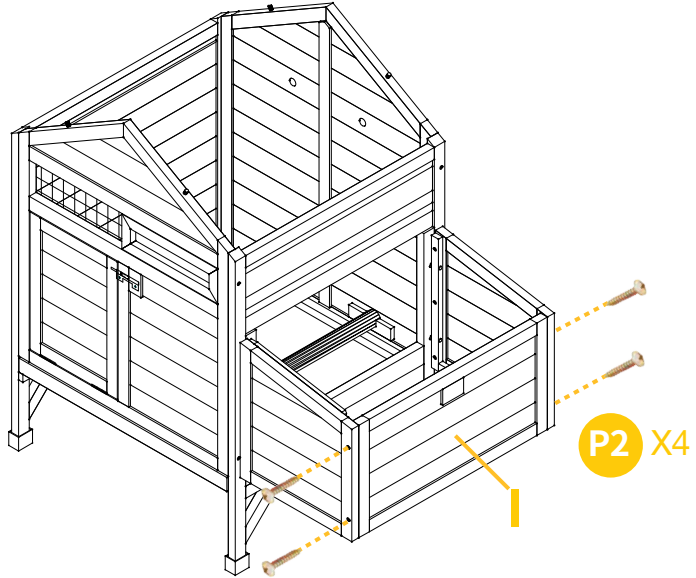

06

Drop in the bottom floor Part J to the nesting box.
Insert the divider Part K into the slots of bottom floor.

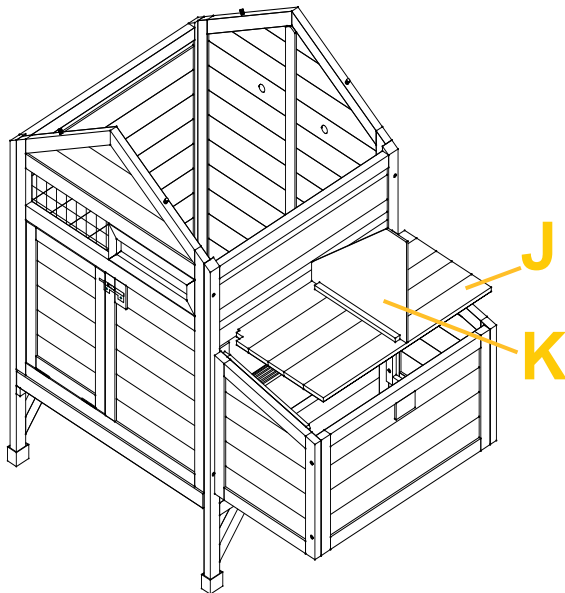

07

PRODUCT ASSEMBLY //

07 Attach the roof of nesting box Part L by 6XP5 screws.

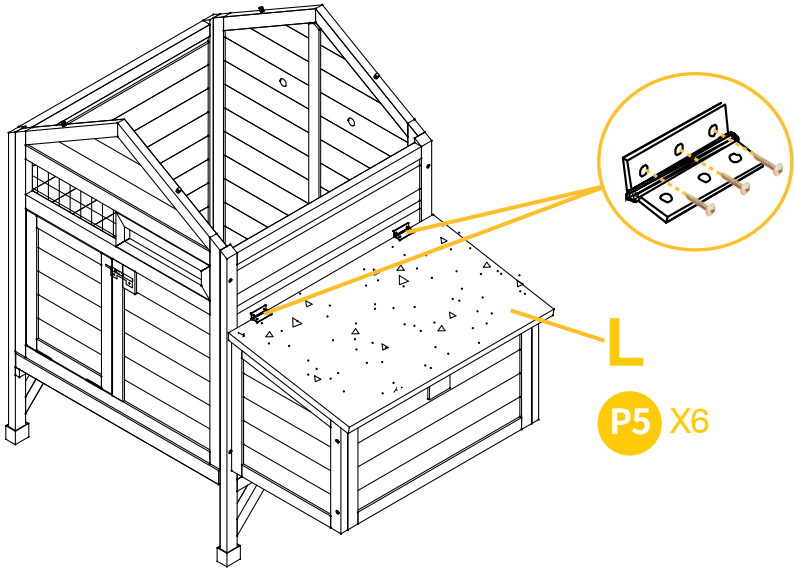

08 Attach the PVC Waterproof Strip Part M to the nesting box by 3XP4 screws.

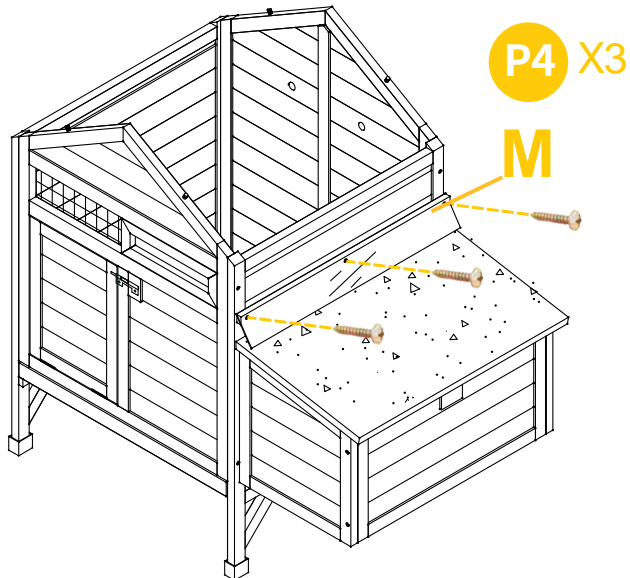

PRODUCT ASSEMBLY //

- 09** Attach the support Part N to the nesting box bottom of left side by 2XP1 screws.

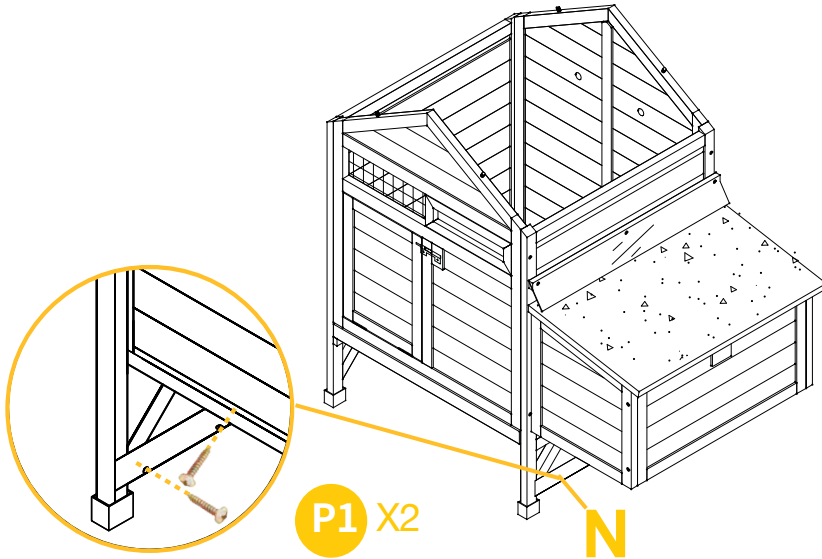

- 10** Attach the support Part N to the nesting box bottom of right side by 2XP1 screws.

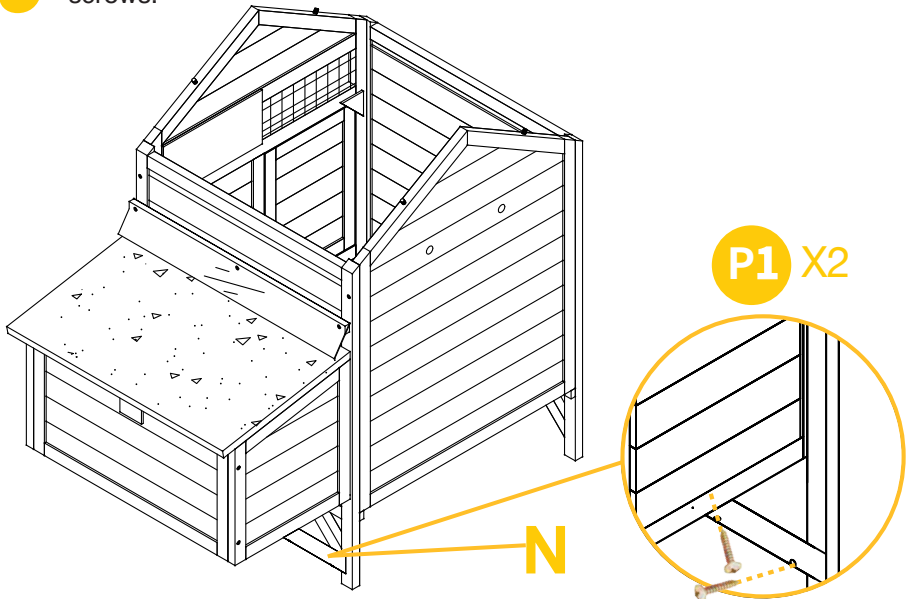

PRODUCT ASSEMBLY

11

Attach the roof Part O to the coop by 8xP3 screws.

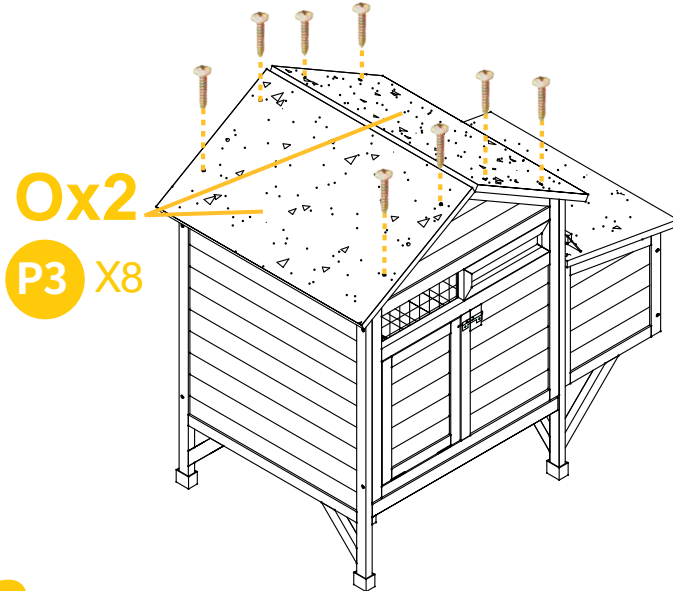

12

Ensure top roof panels line up with each other before screwing the cap Part P by 4xP4 screws.

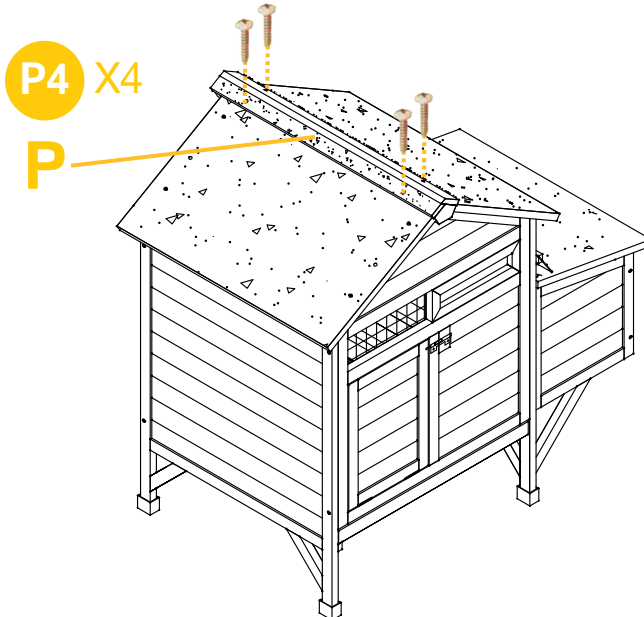



WARNING

Manufacturer and seller expressly disclaim any and all liability for personal injury, property damage or loss, whether direct, indirect, or incidental, resulting from the incorrect attachment, improper use, inadequate maintenance, or neglect of this product.