

# YARD COMMANDER

## 48" PLUG AERATOR OWNER'S MANUAL

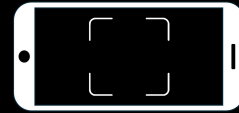

SCAN ME



48-Inch Plug Aerator

Scan QR code with your phone's camera to access testimonials, manuals, in use videos, maintenance guides and view related items.



**YTL-694-466**



### **WARNING:**

Read carefully and understand all **ASSEMBLY AND OPERATION INSTRUCTIONS** before operating. Failure to follow the safety rules and other basic safety precautions may result in serious personal injury.

Thank you very much for choosing this Yard Commander product! For future reference, please complete the owner's record below:

Model: \_\_\_\_\_ Purchase Date: \_\_\_\_\_

Save the receipt, warranty and these instructions. It is important that you read the entire manual to become familiar with this product before you begin using it.

This product is designed for certain applications only. The manufacturer cannot be responsible for issues arising from modification. We strongly recommend this product not be modified and/or used for any application other than that for which it was designed. If you have any questions relative to a particular application, DO NOT use the product until you have first contacted us to determine if it can or should be performed on the product.

For technical questions please call: 888-723-6534

## INTENDED USE

This tow-behind aerator helps to get water and nutrients to the roots of plants in compacted soil.

## TECHNICAL SPECIFICATIONS

Item	Description
Working Width	48"
Wheels	10" pneumatic
Construction	Steel

## GENERAL SAFETY RULES



**WARNING:** Read and understand all instructions. Failure to follow all instructions listed below may result in serious injury.



**CAUTION:** Do not allow persons to operate or assemble this aerator until they have read this manual and have developed a thorough understanding of how the aerator works.



**WARNING:** The warnings, cautions, and instructions discussed in this instruction manual cannot cover all possible conditions or situations that could occur. It must be understood by the operator that common sense and caution are factors which cannot be built into this product, but must be supplied by the operator.

## SAVE THESE INSTRUCTIONS

### WORK AREA

- **Keep work area clean**, free of clutter and well lit. Cluttered and dark work areas can cause accidents.
- **Keep children and bystanders** away while operating the aerator . Distractions can cause you to lose control, so visitors should remain at a safe distance from the work area.
- **Be aware of all power lines, electrical circuits**, water pipes and other mechanical hazards in your work area, particularly those hazards below the work surface hidden from the operator's view that may be unintentionally contacted and may cause personal harm or property damage.
- **Be alert of your surroundings.**

### PERSONAL SAFETY

- **Stay alert**, watch what you are doing and use common sense when using the aerator . Do not use the aerator while you are tired or under the influence of drugs, alcohol or medication. A moment of inattention while operating the aerator may result in serious personal injury.
- **Dress properly.** Do not wear loose clothing, dangling objects, or jewelry. Keep your hair, clothing and gloves away from moving parts.
- **Use safety apparel and equipment.** Use safety goggles or safety glasses with side shields which comply with current national standards, or when needed, a face shield. Also use non-skid safety shoes, hardhat, heavy-duty work gloves, dust collection systems, and hearing protection when appropriate.

### AERATOR USE AND CARE

- **Do not modify aerator in any way.** Unauthorized modification may impair the function and/or safety and could affect the life of the equipment. There are specific applications for which the aerator was designed.
- **Always check for damaged or worn out parts before using the aerator .** Broken parts will affect the aerator operation. Replace or repair damaged or worn parts immediately.
- **Do not exceed the aerator load capacity.**
- **Distribute the load evenly.** Uneven loads may cause the aerator to tip, resulting in personal injury to the operator or others.
- **Use the aerator on flat and level surfaces** capable of supporting the aerator and its maximum load. Pulling or pushing a load on a slanted or uneven surface can result in loss of control.
- **Storing aerator .** When the aerator is not in use, store it in a secure place out of the reach of children. Inspect it for good working condition prior to storage and before re-use.
- **Product is not designed to be used with zero-turn mowers.**

## Pre-assembly Instructions:

For best results, follow all directions step by step.

Read entire instruction manual first, then proceed with set up.

Open all boxes before beginning to assemble and check parts and hardware.

HELPFUL TIP: Read ALL instructions before starting to assemble.

## Check Parts and Hardware:

Group together and check that all hardware and parts are included.

Refer to parts and hardware illustrations below.

If you are missing parts, contact Customer Service at 218-943-6296 for missing hardware or parts.

## Recommended Tools for Assembly:

1 each Combination Wrench 10mm, 11 mm, 12mm, 13mm, 19mm (one ratcheting for faster work)

1 \_Adjustable Wrench Medium Size

1 \_Medium Size Pliers

1 Tape Measure may be useful to measure parts

## PARTS LISTINGS:

### Main Parts Listing

Ref#	Part#	Qty	Description
1	AE48-01	1	Top Tray
2	AE48-02	3	Wheel Bracket
3	AE48-03	1	Middle Brace
4	AE48-04	1	Hitch Bracket
5	AE48-05	1	Tongue
6	AE48-06	2	End Plate

Ref#	Part#	Qty	Description
7	AE48-07	1	Lift Handle
8	AE48-08	1	Axle/ Shaft
9	AE48-09	4	Double Spool Assembly
10	AE48-10	2	Wheel Assembly

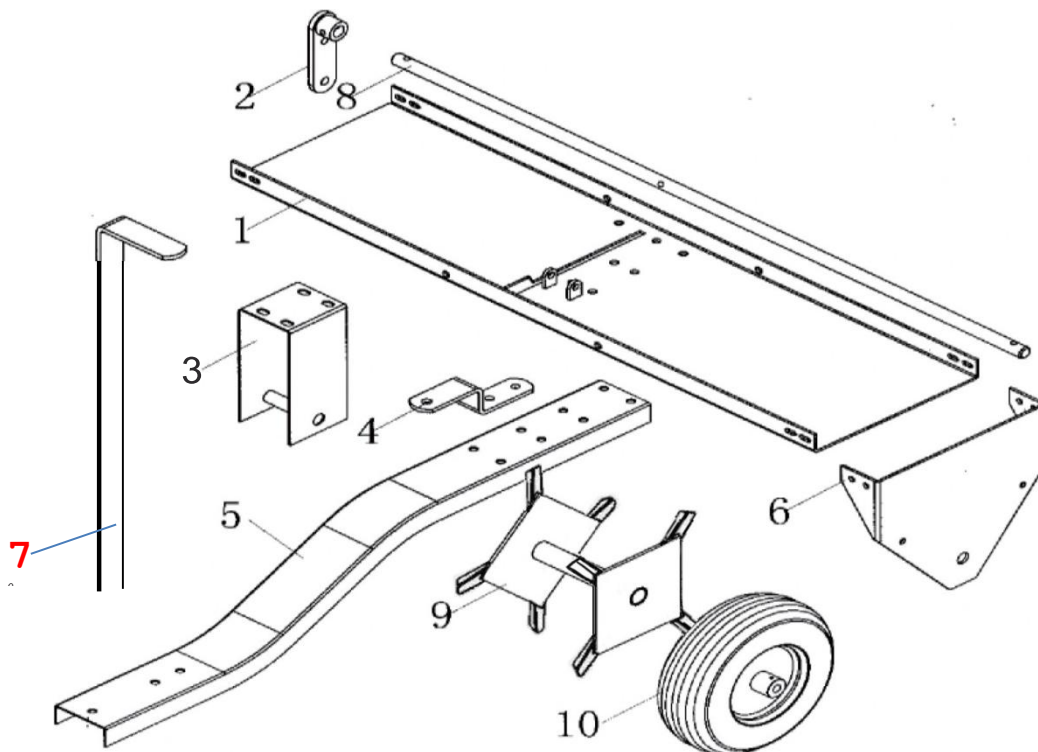

# HARDWARE PARTS: (not actual size)

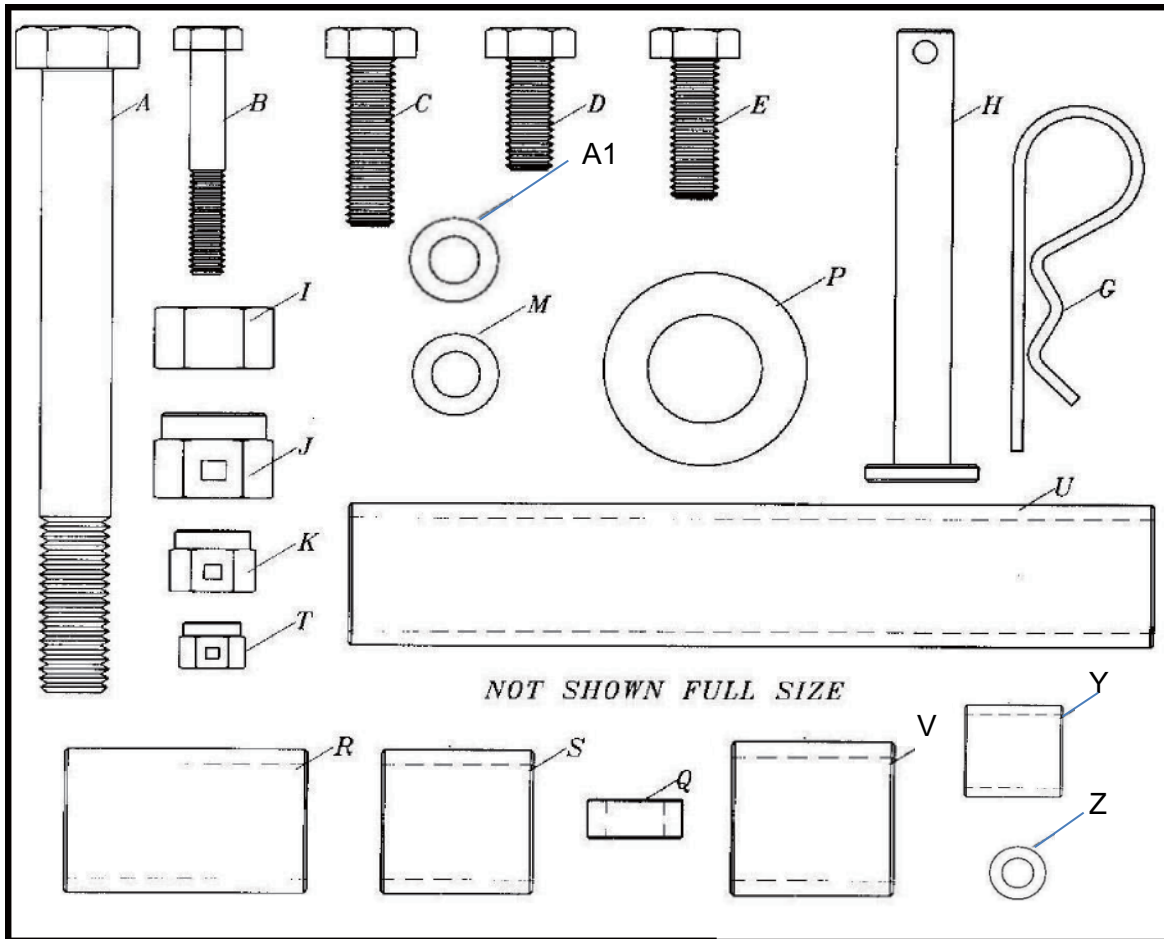

## Hardware Pack Listing:

Ref#	Part #	Qty	Description
A	AE48-A	2	Hex Bolt M12 x 110mm
B	AE48-BT	3	Hex Bolt M6 x 40mm
C	AE48-C	4	Hex Bolt M8x 30mm
D	AE48-D	10	Hex Bolt M8 x 16mm
E	AE48-E	8	Hex Bolt M8 x 20mm
F	AE48-F	1	Lock Pin (Not Shown)
G	AE48-G	1	Hair Cotter Pin
H	AE48-H	1	Hitch Pin
I	AE48-I	2	Hex Nut, M12

Ref#	Part #	Qty	Description
J	AE48-J	2	Lock Nut, M12
K	AE48-K	22	Lock Nut, M8
M	AE48-M	22	Flat Washer, M8
P	AE48-P	4	Flat Washer, 22mm
Q	AE48-Q	8	Spacer 6mm long
R	AE48-RT	1	Spacer Tube, 53mm
S	AE48-S	1	Spacer Tube, 25mm
T	AE48-TT	3	Lock Nut, M6
U	AE48-U	2	Spacer Tube, 134mm
V	AE48-V	2	Spacer Tube 38mm
Y	AE48-Y	2	Spacer Tube 12mm
Z	AE48-Z	3	Flat Washer, 6mm
A1	AE48-A1	4	Flat Washer, 12mm

# Assembly Instructions:

## Step 1:

- Assembling Tongue & Middle Bracket to Top Tray as shown in Figure 1

### Hardware Needed

- 1- Top Tray: Ref #1
- 1- Tongue: Ref #5
- 1- Middle Brace: Ref #3
- 6- Hex Bolt 8mm x 20mm: Ref # E
- 6 - 8 mm Flat washer: Ref # M
- 6- 8mm Lock nut: Ref # K

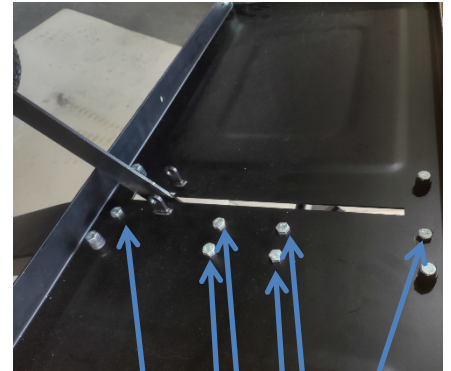
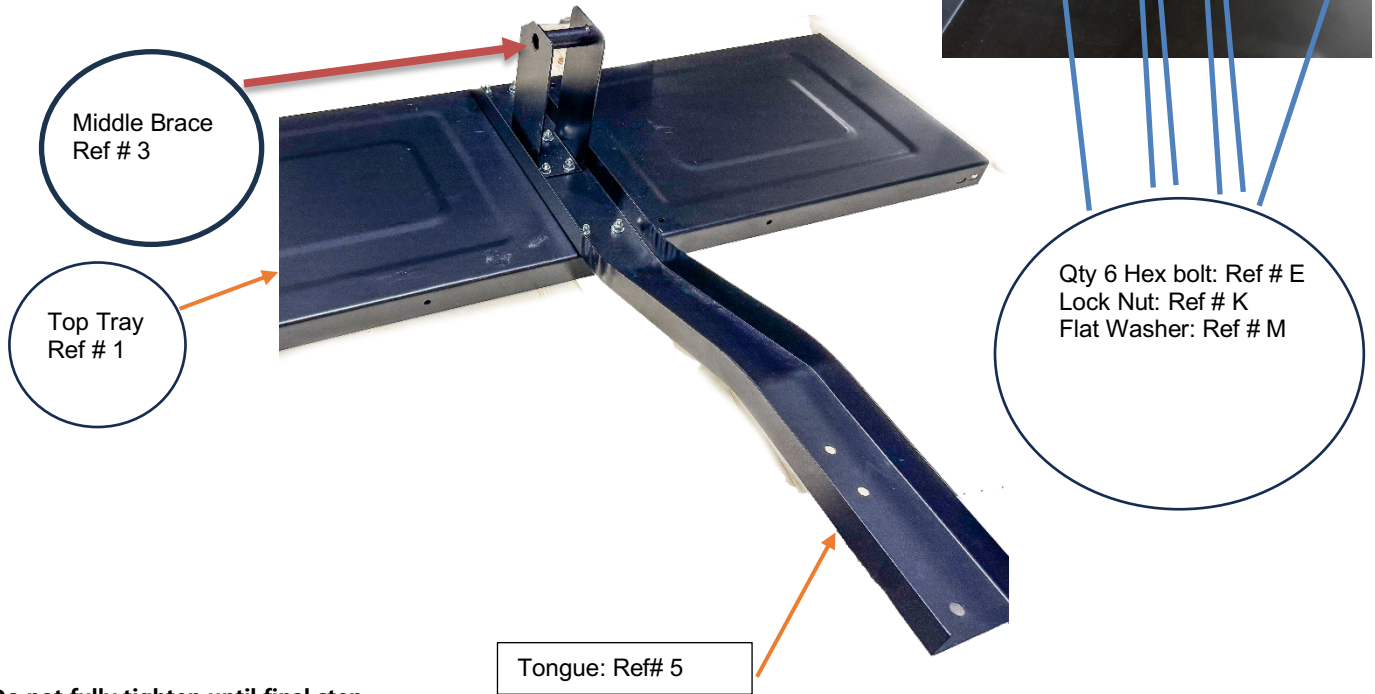

Figure 1



Do not fully tighten until final step.

## Step 2: Determine Short and Long Side of Axle/ Shaft

### Hardware Needed

- 1- Axle/ Shaft: Ref #8

Figure 2

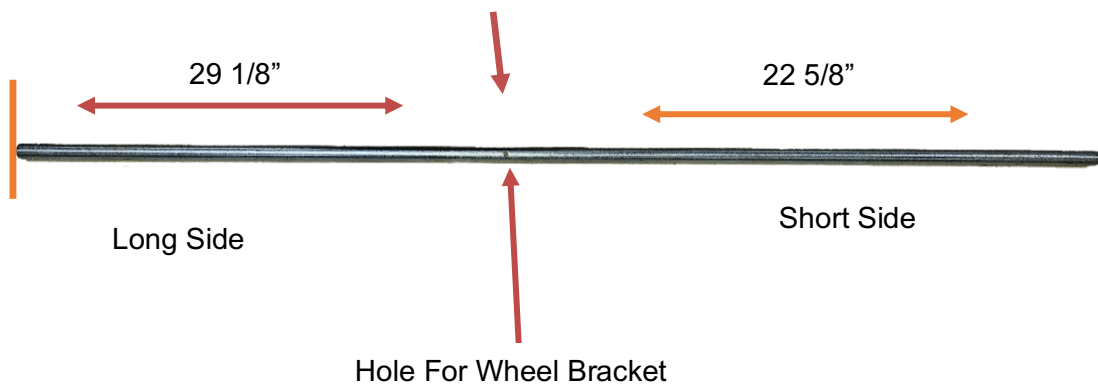

Step 3: Assemble Short Side of Axle/ Shaft as Shown in Figure 3 below.

Hardware needed:

- 1- 22mm Flat washer: Ref # P
- 1- Spacer Tube 25mm: Ref # S
- 1- Wheel Bracket: Ref # 2
- 2- Double Spool Assembly: Ref # 9
- 1- Space Tube 134mm: Ref # U
- 1- Spacer Tube 38mm: Ref # V
- 1- Hex Bolts M6x40 Ref # B
- 1- 6 mm Flat washer: Ref # Z
- 1- Lock Nuts M6 Ref # T

Figure 3

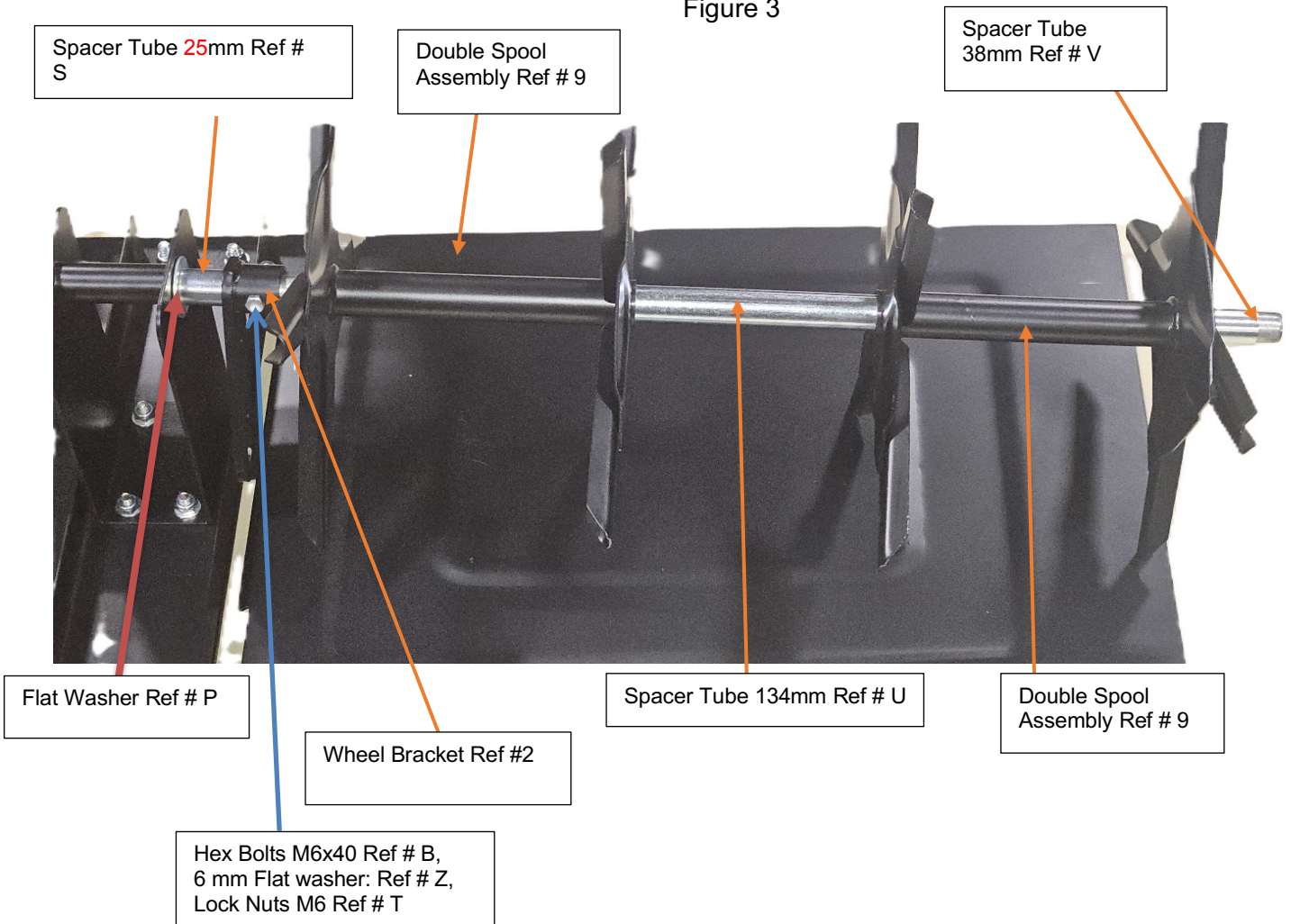

**Step 4:**

Assemble Long side of Axle/ Shaft as shown in Figure 4 below

Hardware needed:

- 1- 22 mm Flat Washer: Reference # P
- 1- Spacer Tube 53mm: Reference # R
- 2- Double Spool Assembly's: Reference # 9
- 1- Spacer Tube 134mm: Reference # U
- 1- Spacer Tube 38mm Reference # V.

Figure 4

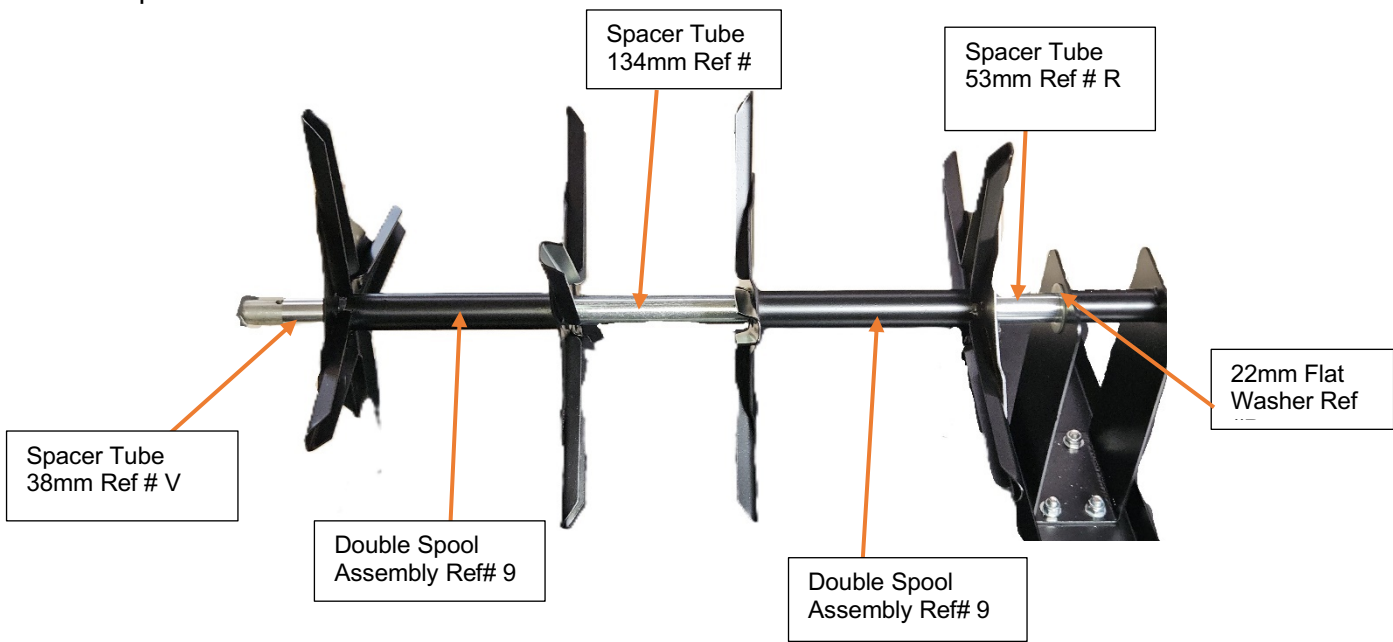

**Step 5:**

Assemble End Plats onto Top Tray as shown in Figure 5. Assemble both End Plates.

Hardware Needed:

- 2- End Plates: Ref # 6
- 8- Hex bolts 8mm x 16mm Ref # D
- 8- Lock Nuts: Ref #K
- 8 - 8 mm Flat washer: Ref # M

Figure 5

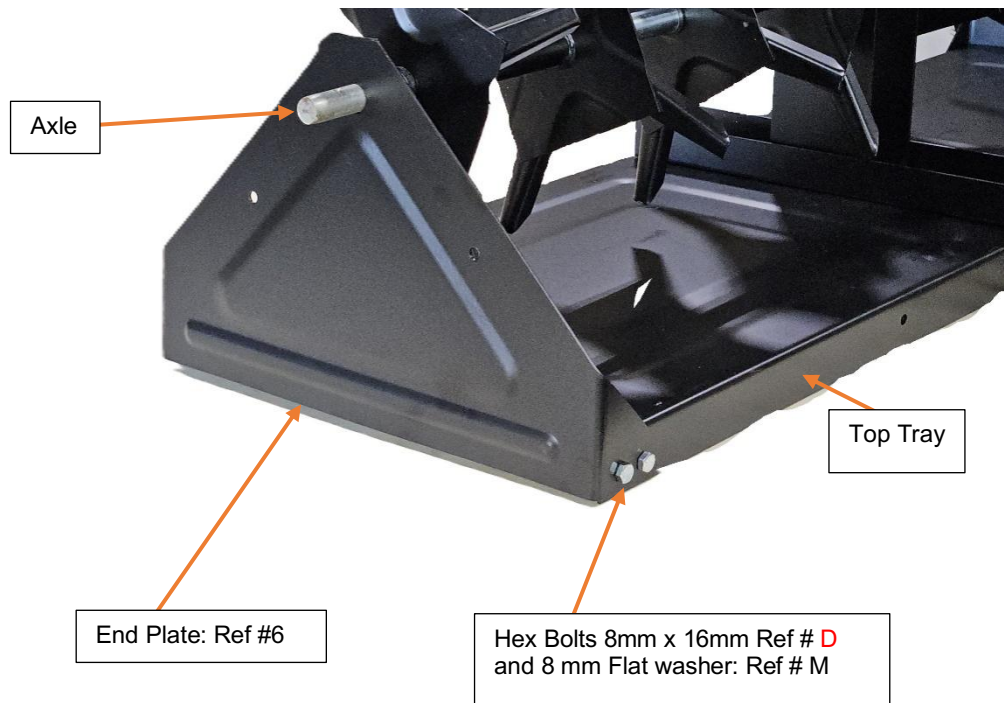

Step 6: Assemble the lift handle to the wheel bracket on axle shaft as shown in Figure 6 & 6A.

**Step 6 Hardware Needed**

- 1- Lift Handle Ref # 7
- 2- Hex Bolts M8x20mm Ref # E
- 2- Lock Nuts M8 Ref # K
- 2 - 8 mm Flat washer: Ref # M

Figure 6

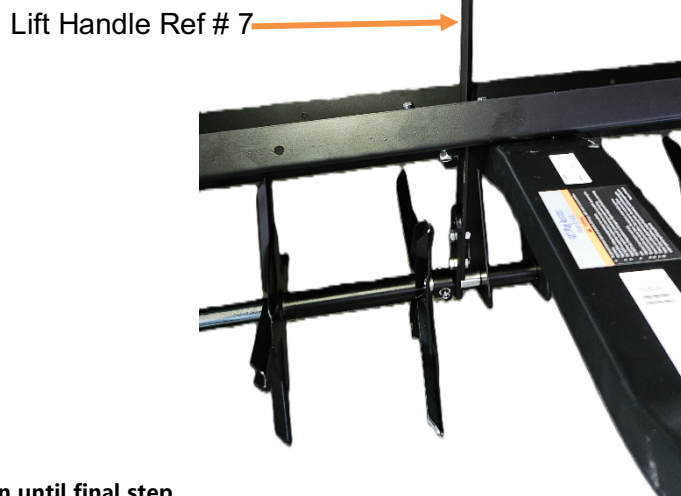

Figure 6A



**Do not fully tighten until final step.**

Step 7: Assemble the wheel bracket & wheel assembly as shown in Figure 7.

**Step 7 Hardware Needed**

- 2- Wheel Brackets Ref # 2
- 2- Wheel Assembly's Ref # 10
- 2- Hex Bolt M12x110mm Ref # A
- 2- Lock Nuts M12 Ref # J
- 2- Hex Nuts M12 Ref # I
- 2- Hex Bolts M6x40 Ref # B
- 2- Lock Nuts M6 Ref # T
- 2- Flat Washers 22mm Ref # P
- 2 - 6 mm Flat washer: Ref # Z
- 2- Spacer Tube 12mm: Ref # Y
- 4- Flat Washers 12mm Ref # A1

Figure 7

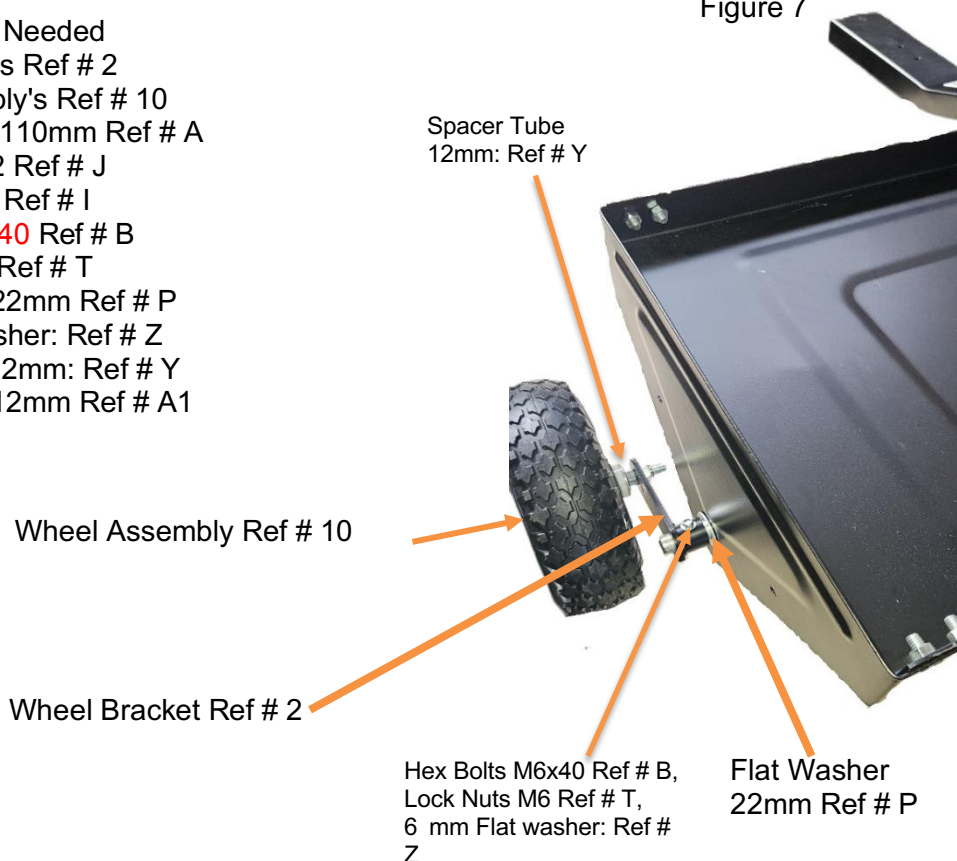

Step 8: Top Tray Weight Stops. Install weight stops as shown in Figure 8

Hardware Needed

- 4- Hexbolts M8x30mm Ref # C
- 4- Lock Nut M8 Ref # K
- 4- Flat Washer M8 Ref # M
- 8- Spacer 6mm Long Ref # Q

Figure 8



Install Hex Bolt M8x30 Ref # C, Flatwasher M8 Ref # M, qty 2 Spacer 6mm Long through top tray and assemble with Lock Nut M8 Ref # K

Step 9: Assemble Hitch Bracket & Hitch Pin onto Tongue as shown in Figure 9

Hardware Needed

- 1- Hitch Bracket Ref # 4
- 2- Hex Bolt M8x16mm Ref D
- 2- Lock Nut M8 Ref # K
- 1- Hitch Pin Ref # H
- 1- Hair Cotter Pin # G
- 2 - 8 mm Flat washer: Ref # M

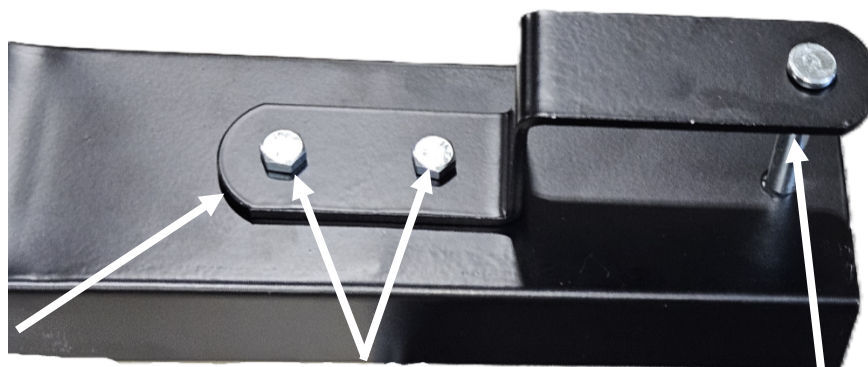

Hitch Bracket Ref # 4

Hex Bolt M8x19mm Ref # D  
Lock Nut M8 Ref # M

Hitch Pin Ref # H

## Final Step: Check Handle & Tighten Connections

Carefully place the aerator upright on the wheels.

Check that lift handle moves freely with-in slot;

IF NEEDED, make following adjustments

Lock the lift handle by moving into large offset hole in front of tray slot, then secure with locking pin. Refer to Figure #10.

### For #1 in Figure #10:

Adjust the Tray side to side until the lift handle moves freely from back to front

### For #2 in Figure #10:

Re-straighten end plates, then fully tighten all 8 corner connections making sure lift handle still moves freely.

**Tighten middle brace and top tray connections from step 1 and 6**

**CHECK THAT ALL CONNECTIONS ARE TIGHT.**

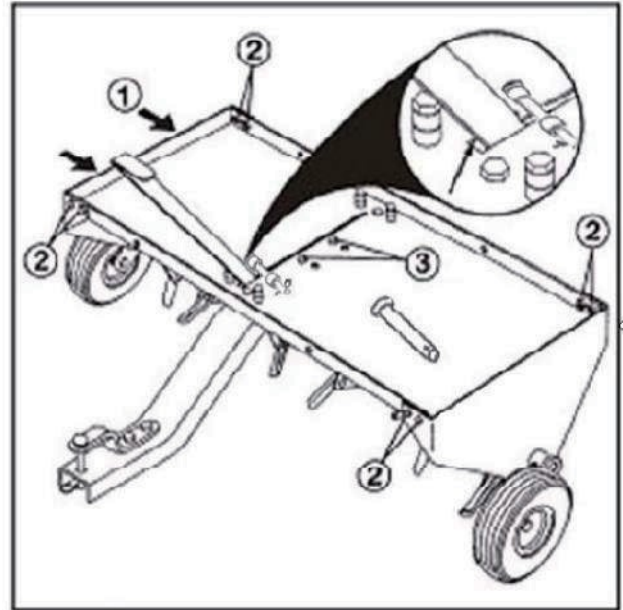

Figure 10

## Figure #10 Close Up Photo

BEHIND THE LIFT ARM on the top tray is a place for locking pin device. Slide locking pin through holes when aerator is in the upright position. This is a safety lock to keep the aerator from dropping down while towing and not in use. This can help prevent damage to plug knives.

Your Aerator is now fully assembled and ready for use.

## MAINTENANCE :

Pluggers knives can be periodically sharpened with a small grinder to have continued good plugs from the soil.

Oil the axle shaft and wheel hubs as needed with spray lubricant or small amount of grease

Clean and dry the aerator before long periods of storage.

DO NOT EXCEED maximum weight capacity on top tray.

# AE-48TL

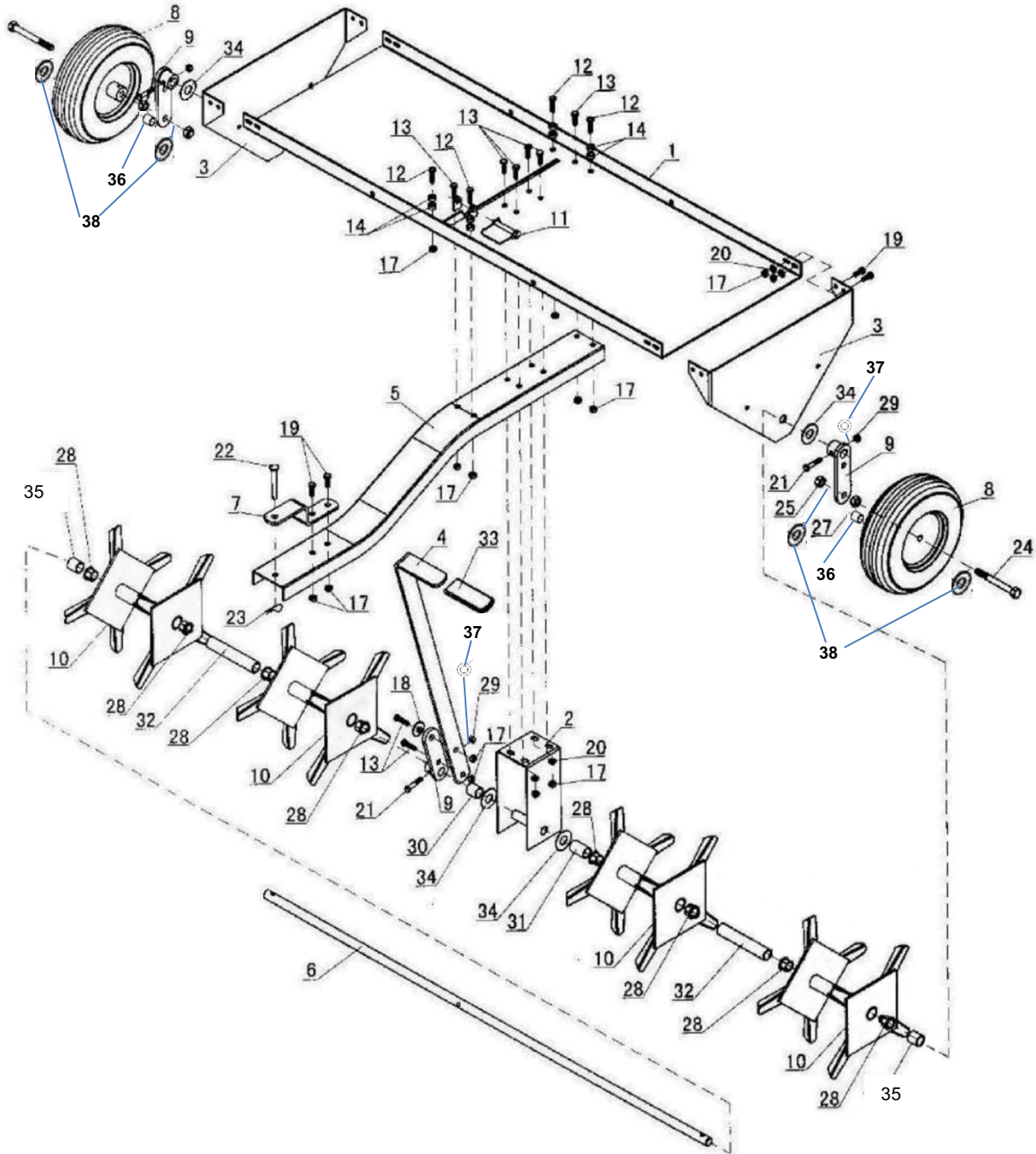

# AE-48TL

Ref#	Part #	Description	QTY
1	AE48-01	Top Tray	1
2	AE48-03	Middle Brace	1
3	AE48-06	End Plate	2
4	AE48-07	Lift Handle	1
5	AE48-05	Tongue	1
6	AE48-08	Axle / Shaft	1
7	AE48-04	Hitch Bracket	1
8	AE48-10	Wheel Assembly	2
9	AE48-02	Wheel Bracket	3
10	AE48-09	Welded Double Spool Assembly	4
11	AE48-F	Lock Pin M10X70	1
12	AE48-C	Hex Bolt M8 x 30	4
13	AE48-E	Hex Bolt M8 x 20mm	8
14	AE48-Q	Spacer 6mm	8

Ref#	Part #	Description	QTY
17	AE48-K	Lock Nut, M8	22
19	AE48-D	Hex Bolt M8 x 16	10
20	AE48-M	Flat Washer, 8mm	22
21	AE48-BT	Hex Bolt M6 x 40	3
22	AE48-H	Hitch Pin	1
23	AE48-G	Hair Cotter Pin	1
24	AE48-A	Hex Bolt M12 110	2
25	AE48-J	Lock Nut, M12	2
27	AE48-I	Hex Nut, M12	2
28	AE-48X	Split Plastic Bearing	8
29	AE48-TT	Lock Nut, M6	3
30	AE48-S	Spacer Tube, 25mm	1
31	AE48-RT	Spacer Tube, 53mm	1
32	AE48-U	Spacer Tube, 134mm	2
33	AE-48W	Handle Grip	1
34	AE48-P	Flat Washer, 22	4
35	AE48-V	Spacer 38mm	2
36	AE48-Y	Spacer Tube 12mm	2
37	AE48-Z	Flat Washer, 6mm	3
38	AE48-A1	Flat Washer, 12mm	4

**48" Plug Aerator**  
YTL-694-466

**⚠ WARNING**

1. To prevent serious injury or property damage, read owner's manual before operating.
2. Inspect the work area before each use. Keep work area clean, dry, free of clutter, and well lit. Cluttered, wet, or dark work areas can result in injury.
3. Keep children and bystanders away from the work area while operating the tool. Do not allow children to handle the dethatcher.
4. Wear the proper personal protective equipment when necessary. Use ANSI compliant safety goggles/safety glasses with side shields, or when needed, a face shield. Use a dust mask in dusty work conditions. Also use non-skid safety shoes/boots, hardhat, heavy-duty work gloves, dust collection systems, and hearing protection when appropriate. This applies to ALL persons in the work area.
5. Never allow riders on equipment or tow vehicle.
6. DO NOT exceed this implement's maximum speed of 5 MPH. Exceeding this speed may result in loss of control during transport or braking.
7. DO NOT use if equipment is damaged. Repair equipment before continuing use.
8. Operate from lawn tractor/ATV seat only.
9. Sharp points can cause injury. Store out of reach of children. Not for use by or around children.

Made in Thailand

Made in Thailand

# **WARRANTY**

---

## **Limited Warranty**

YTL International warrants that the product is free from defects in material and workmanship under normal use for

this warranty, YTL International shall, at its exclusive option, either repair or replace the product (lawn sweeper). YTL International shall have no obligation under the warranty set forth above if the original purchaser or other person: improperly assembles the product, misuses the product, overloads the product, operates or uses the product contrarily to instructions, or if the product has been repaired or altered by anyone other than an authorized representative.

## **Limited Warranty Exclusions**

The limited warranty does not cover cosmetic defects, including, but not limited to, product paint and decals; nor does it cover items subject to ordinary wear from use of the product, including, but not limited to, tires. The warranty shall be voided by alteration of the product (except by YTL International), tampering with, improper installation or maintenance, accident or misuse. This warranty expressly excludes all damage to the product resulting from careless or neglectful handling or transportation once it has left YTL International's premises.

The product (lawn sweeper) requires consistent, periodic service for optimal performance and normal maintenance of the product is expressly excluded from the warranty. The warranty does not cover repair when normal use has exhausted the life of a part or the equipment as a whole. YTL International also does not warranty consumable

The warranty will not apply to parts and/or labor if the product (lawn sweeper) has been misused, neglected,

## **Limits of Implied Warranty and Consequential Damage Exclusion**

YTL International disclaims any obligation to cover any loss of time, use of this product, freight, or any incidental or consequential claim by anyone from using this lawn sweeper. This warranty is given in place of all other

for purpose, or merchantability and the vendor accepts no liability, under any circumstances whatsoever, for any consequential damage or loss suffered by anyone as a result of using or being unable to use the product.

An exchanged/replaced product will be subject to the original limited warranty and warranty coverage will be calculated from the purchase date of the original product.