



1 YEAR LIMITED WARRANTY

TELESOPES

BARSKA® Optics, as manufacturer, warrants this new precision optical product to be free of original defects in materials and/or workmanship for the length of time specified by this warranty. This warranty does not include damage caused by abuse, improper handling, installation, maintenance, normal wear-and-tear, unauthorized repairs or modifications and tampering in anyway. This warranty is limited to the original purchaser and is not transferable.

This warranty applies only to products purchased in the United States of America and Canada.

In the event of a defect within 30 days, the consumer must return the defective unit to the BARSKA dealer (the place of purchase) at his/her own expense.

Beyond 30 days, BARSKA products should be sent to the following address for warranty repairs. Products must be packed carefully and sturdily to prevent damage in transit, and returned freight prepaid to:

BARSKA® OPTICS
855 Towne Center Drive
Pomona, CA 91767

For additional and updated information
please visit our website at www.barska.com

Please email info@barska.com or call 1.888.666.6769 for Return Merchandise Number (RMA#) before any returns. NOTE: All merchandise received without a valid RMA # will be returned to shipper at his/her own expense.

Please include all of the following when returning BARSKA products for service and/or replacement:

1. Please write your complete details (Name, Address, Telephone #, E-mail address, RMA#, etc.)
 2. Purchase receipt or Proof of Purchase. (Original/Copy)
 3. A brief explanation of the defect.
 4. A Check/Money Order of \$25.00 cover inspection, shipping and handling.
- *Please allow 6-8 weeks for delivery.

This product will either be replaced or repaired at the discretion of the warrantor. If it's a discontinued item, we will replace the product with an equivalent product. Should the repair not be covered by this warranty, an estimate will be sent for your approval. Non-warranty repairs or refurbishing of your optical products are always provided at a reasonable cost.

BARSKA® shall not be liable for any consequential, incidental and/or contingent damages whatsoever. We will not pay shipping, insurance or transportation charges from you to us, or any import fees, duties and or taxes. This warranty supersedes all previous BARSKA warranties.



TELESCOPE
STARWATCHER
231 POWER > 0060
HIGHEST ATTAINABLE POWER

CAUTION: DO NOT LOOK DIRECTLY AT THE SUN. VIEWING THE SUN OR ANY LIGHT SOURCE WITH THIS OPTICAL DEVICE CAN CAUSE PERMANENT EYE DAMAGE.



- | | |
|---|--------------------------|
| 1. Tripod Brace with Leg Adjustment Screw | 7. Eyepiece |
| 2. Accessory Tray | 8. Finderscope |
| 3. Tripod Leg | 9. Finderscope Bracket |
| 4. Vertical Axis Handle | 10. Telescope Main Body |
| 5. Focus Knob | 11. Objective Lens |
| 6. Rotating Diagonal | 12. Horizontal Axis Knob |

Setup Instructions

Unpack and lay out all of the parts in a large, clear area where you will have room to assemble the pieces.

1. Fully extend the legs of the tripod apart
2. Under the plate of the tripod head is locking screw for the tripod head
3. Place the telescope tube on the mount so that the screw in the mounting platform lines up with the holes in the telescope
4. Keep telescope in place by tightening the mounting plate adjustment

Initial set up is shown in the picture on the left. Should look like picture on the right when finished.



5. Remove caps from telescope

Note: When mounting the parts ensure that the securing screws are not tightened too tightly. Tightening too tightly could result in damage the parts or the internal thread of the holders.

Attaching the Accessories

Accessory Tray

1. Included with the telescope is an accessory tray that is mounted in the center and on the leg braces. If necessary fully extend the legs of the tripod apart.

Initial set up is shown in the picture on the left. Should look like picture on the right when finished.

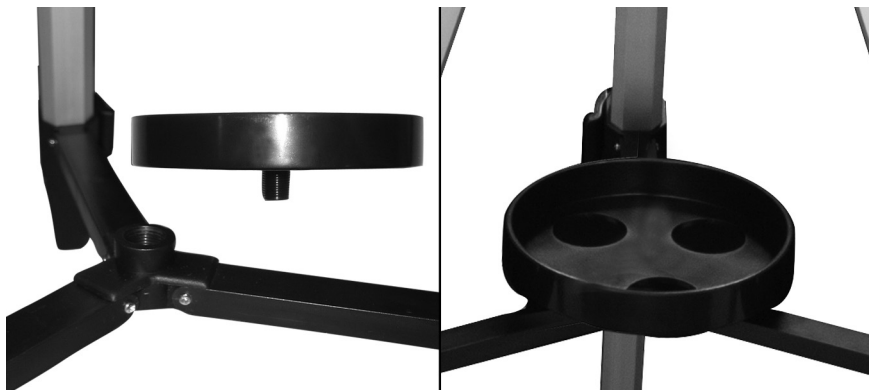

Eyepiece

1. Select an eyepiece, place it into the rotating diagonal. Lock the eyepiece into place with the thumb screw.

Barlow Lens

The included 3x Barlow lens triples the magnifying power of each eyepiece. See Barlow Lens page 7

Eyepiece initial set up is shown in the picture on the left. Should look like picture on the right when finished.

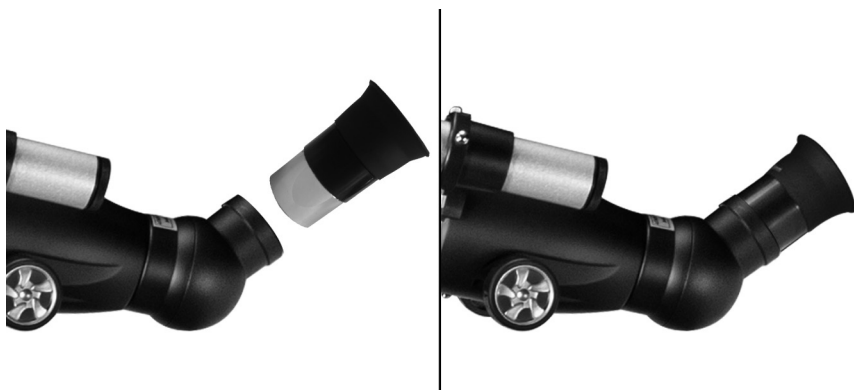

Finderscope

The mount of the finderscope bracket slides into the main body of the telescope. Located between the compass and the focus knob.

1. Unscrew the 3 silver thumbscrews located on the finderscope bracket and place the finderscope through the opening of the finderscope bracket. Tighten the 3 silver thumbscrews to keep finderscope in place.
2. Slide the finderscope bracket into the body of the telescope, located between the compass and the focus knob.
3. Remove cap from the eyepiece of the finderscope.
4. If necessary adjust the thumb screw of finderscope bracket to change the angle of viewing for the finderscope.

Initial set up is shown in the picture on the left. Should look like picture on the right when finished.

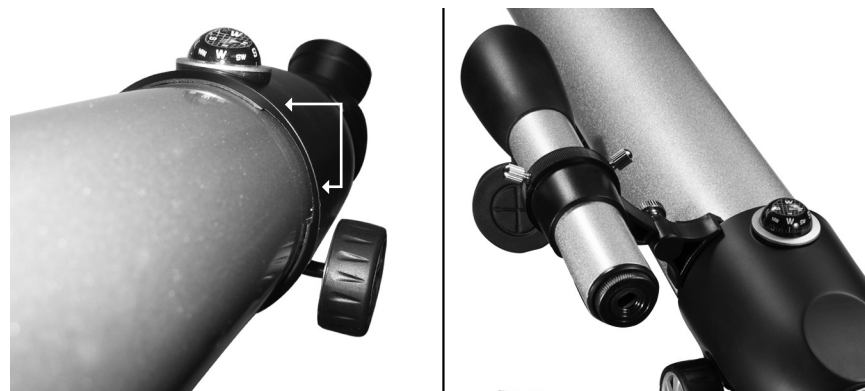

How to Use Telescope:

First try out your telescope in the daytime and learn to use the telescope looking at easily identifiable objects. Get familiar with the telescope's movements, pointing, focusing, different eyepieces, and magnifying powers. Below is some information on how to use the telescope.

Telescope Movement:

In order to move the telescope horizontally (left to right)
 - Loosen Horizontal Axis Screw

In order to move the telescope vertically (up and down)
 - Turn the Tripod Handle to the left to loosen the tripod vertically allowing movement.

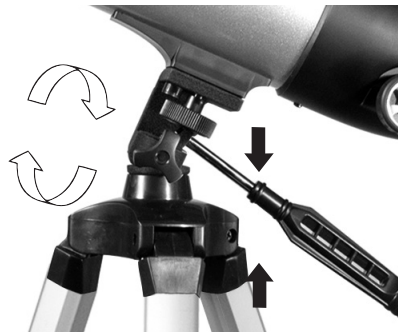

Adjusting the Finder Scope:

Since the telescope has a limited field of view, it can be quite difficult to locate a given star or planet. For this reason the telescope is fitted with a finder scope with reticule for orientation. It is advisable to complete the following settings in daylight.

1. Insert the eyepiece with the lowest magnification in the Zenith mirror or Zenith prism. Look at a stationary easily recognizable object that is not further away than 300m. Turn the telescope with the horizontal axle, and move the vertical axle until the object is in the middle of the field of view, and then focus the image. Tighten the adjusting screw on the mount so that the telescope remains in this position (the higher the object is above the horizon, the easier it is to locate).
2. Now look through the finder scope. If the object seen through the telescope is not visible, then release the adjusting screws and move the finder scope until the object can be seen. Now retighten the adjusting screw while ensuring that the object remains visible in the centre of the finder scope. To simplify this procedure use the adjusting screws to adjust the object in the centre. The finder scope will move in the direction of the screw in which it is being turned. All screws can be finally tightened as soon as the setting with the eyepiece coincides with that of the finder scope.

WHICH MAGNIFICATION? SELECTING THE CORRECT EYEPIECE

Magnification defines the power of a telescope to enlarge an image or to 'pull it in' closer for viewing.

Example:

$$\frac{700\text{mm focal length}}{12.5\text{mm focal length of eyepiece}} = 56 \times \text{magnification}$$

The required magnification depends upon the object being observed. The following general guideline is recommended for this purpose: Ideal viewing conditions are obtained if the magnification is not more than 15x - 20x the diameter of the objective lens, i.e. an optimal magnification of 100x - 125x can be expected with 60 mm diameter objective lens to observe most celestial objects. A lower magnification power is advisable for the observation of stars.

The field of view is wider so that the object for observation is more easily localized. The highest magnification power should only be used for particularly clear observations of the moon an object that is relatively close and exceptionally bright, so that good detail resolution is achieved at high magnification ratios.

Barlow Lens:

The Barlow lens increases the magnification of the telescope. A 3x Barlow lens will therefore triple the telescope's magnification power. Consequently a 56x magnification can be tripled to 168x with a 3x Barlow lens. The highest magnification power of the Barlow lens should only be used for large and bright objects such as the moon and the brightest planets, as well as for nights with optimal observation conditions.

To use the Barlow lens take the angle prism out of the tube. Insert the Barlow lens into the rotating diagonal and then attach the required eyepiece to the Barlow lens, focusing is then completed in the customary manner.

VERY IMPORTANT GENERAL REMARKS

CAUTION

TO AVOID EYE DAMAGE NEVER LOOK THROUGH THE TELESCOPE INTO ANOTHER OPTICAL INSTRUMENT, INTO THE SUN OR A LIGHT SOURCE. NEVER LEAVE THE TELESCOPE UNATTENDED, A CHILD COULD LOOK AT THE SUN WITH IT AND SUFFER PERMANENT EYE DAMAGE.

Avoid sudden temperature fluctuations as the moisture in the air will condense on the objective lens. Should this happen, then place the objective lens not too close to a source of heat and allow the moisture to evaporate slowly.

When mounting the parts ensure that the securing screws are not tightened too firmly. This could damage the parts or the internal thread of the holders with the result that the screws can no longer be tightened.