

## Desk with 2 drawers

Bureau avec 2 tiroirs

Schreibtisch mit 2 Schubladen

Scrivania con 2 cassetti

Escritorio con 2 cajones

引き出し2個付きデスク

侧框书桌

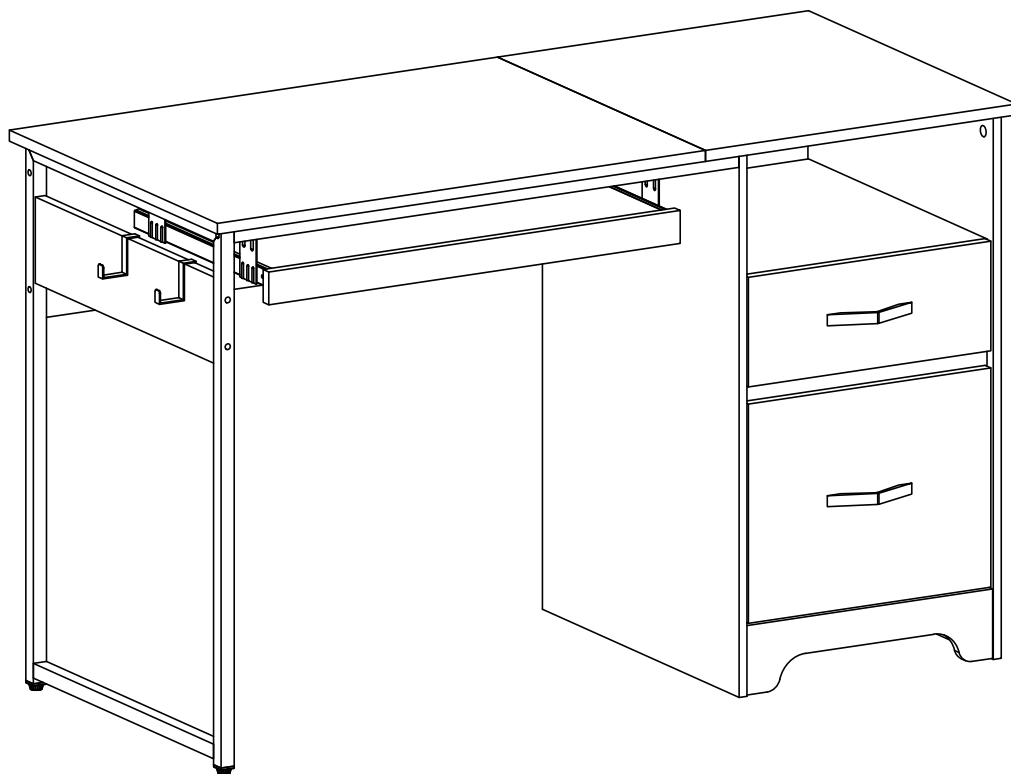

### ASSEMBLY INSTRUCTION

Montageanleitung  
Instructions De Montage  
Istruzioni Per L'assemblaggio  
Instrucciones De Montaje  
組立説明書  
安装说明书



## HELPFUL HINTS

### BEFORE YOU START

- Inspect product packaging to ensure the appearance is good.
- Read the assembly instruction carefully and follow it step by step.
- To avoid any scratching, putting a soft blanket on the floor is suggested.
- Identify, sort and count all the parts with tags.
- Find out installation position according to the drawing and install it in correct steps.

### OTHER

- People needed for assembly: 1-2.
- Estimated assembly time: 0.5-1h.

### CAUTION

- Be cautious when using a power drill or power screwdriver.
- Please be aware to slow down and stop when screw is nearly tight.
- Do Not use any harsh chemicals or abrasive cleaners for this item.
- Push, pull or drag this item carefully.

## ASTUCES UTILES

### AVANT DE COMMENCER

- Inspectez l'emballage du produit pour vous assurer que l'apparence est bonne.
- Lisez attentivement les instructions de montage et suivez-les étape par étape.
- Pour éviter toute rayure, posez une couverture douce sur le sol est suggéré.
- Identifiez, triez et comptez toutes les pièces avec des étiquettes.
- Trouver la position d'installation selon le dessin et l'installer dans les étapes correctes.

### AUTRE

- Personnes nécessaires pour l'assemblage : 1-2.
- Temps de montage estimé : 0.5-1 h.

### AVERTIR

- Soyez prudent lorsque vous utilisez une perceuse électrique ou un tournevis électrique.
- Veuillez être conscient de ralentir et d'arrêter lorsque la vis est presque serrée.
- N'utilisez pas de produits chimiques corrosifs ou de nettoyants abrasifs pour cet article.
- Poussez, tirez ou tirez cet article avec précaution.

## CONSEJOS ÚTILES

### ANTES DE EMPEZAR

- Inspeccione el paquete del producto para asegurarse de que la apariencia es buena.
- Lea atentamente las instrucciones de montaje y sígala paso a paso.
- Para evitar rayas, se sugiere poner una manta suave en el suelo.
- Identifique, clasifique y enumere todas las piezas con etiquetas.
- Averigüe la posición de instalación según el dibujo e instálela en los pasos correctos.

### OTROS

- Personas necesarias para el montaje: 1-2.
- Tiempo de montaje estimado: 0.5-1 h.

### PRECAUCIÓN

- Tenga cuidado al utilizar un taladro eléctrico o un destornillador eléctrico.
- Tenga en cuenta que debe hacerlo más despacio y detenerse cuando el tornillo esté casi apretado.
- No utilice productos químicos agresivos ni limpiadores abrasivos para este artículo.
- Empuje, tire o arrastre este elemento con cuidado.

## SUGGERIMENTI UTILI

### PRIMA DI INIZIARE

- Controllare la confezione del prodotto per assicurarsi che sia in buono stato.
- Leggere con attenzione le istruzioni per l'assemblaggio e seguirle passo dopo passo.
- Per evitare graffi al pavimento, suggeriamo di stendervi una coperta morbida.
- Identificare, suddividere e contare tutte le parti con etichetta.
- Trovare la posizione adatta per il montaggio in base al disegno e montare lo scaffale seguendo correttamente i vari passaggi.

### ALTRO

- Persone necessarie per l'assemblaggio: 1-2.
- Tempo di assemblaggio stimato: 0.5-1 ora.

### ATTENZIONE

- Prestare molta attenzione quando si utilizza un trapano elettrico o un cacciavite elettrico.
- Rallentare con accortezza e fermarsi quando una vite è già sufficientemente serrata.
- Non utilizzare prodotti chimici aggressivi o detergenti abrasivi su questo articolo.
- Spingere, tirare o trascinare questo articolo con cautela.

## NÜTZLICHE HINWEISE

### ⚠️ BEVOR SIE BEGINNEN

- Überprüfen Sie die Produktverpackung auf Schäden.
- Lesen Sie sich die Montageanleitung sorgfältig durch und befolgen Sie sie Schritt für Schritt.
- Um etwaiges Zerkratzen zu vermeiden, wird das Auslegen einer weichen Decke auf dem Boden empfohlen.
- Identifizieren, sortieren und zählen Sie alle Teile mit Tags nach.
- Identifizieren Sie die Montageposition gemäß der Zeichnung und bauen Sie das Regal den richtigen Schritten entsprechend auf.



### SONSTIGES

- Für den Zusammenbau erforderliche Anzahl an Menschen: 1-2.
- Ungefähre Montagedauer: 0.5-1 h.

### ⚠️ VORSICHT

- Seien Sie bei der Verwendung einer Bohrmaschine oder eines Akkuschraubers vorsichtig.
- Bitte vergessen Sie nicht darauf, langsamer zu werden und zu stoppen, sobald die Schraube fast festgezogen ist.
- Verwenden Sie keinerlei aggressive Chemikalien oder scheuernden Reinigungsmittel für dieses Produkt.
- Schieben oder ziehen Sie dieses Produkt vorsichtig.

## 温馨提示

### ⚠️ 安装前注意事项

- 检查产品包装，确保外观良好。
- 仔细阅读安装说明，按步骤操作。
- 为了避免刮伤，建议在地板上放一条柔软的毯子。
- 标识、分类和清点所有部件。
- 根据图形找到安装孔位，按正确步骤安装。



### 其他:

- 组装所需人员: 1-2人。
- 预计组装时间: 0.5-1小时。

### ⚠️ 注意:

- 小心使用电钻或电动螺丝刀。
- 当螺丝快要拧紧时，请注意减速。
- 不要使用任何刺激性化学物质或擦洗剂。
- 当推、拉或拖动产品时，注意小心谨慎，防止损坏。

## 役に立つヒント

### ⚠️ 組立の場所を確保し、順番通りに組み立てる

- 組立場所（充分広くて平たい場 所）を確保してください。
- 床や壁、商品を傷つけないように、商品の下に厚めの布や段ボールなどを敷いてください。
- 組立の順番を守らないと、組立できなくなったり、商品を傷つけたりします。



### その他

- 組み立てに必要な人: 1-2。
- 組立時間: 約0.5~1時間。

### ⚠️ 部品を確認する

- ネジ類などの部品番号、形状を説明書の部品一覧で確認してください。
- 部品をなくさないように纏めて置いてください。
- 部品を取り出すときに使う分だけ取り出してください。

# DETAILS

DETAILS  
DÉTAILS/POINTS DE MONTAGE  
NOTE PARTICOLARI

DETALLES  
組み立てのポイント  
詳細情報

UNIT:INCH/CM/厘米

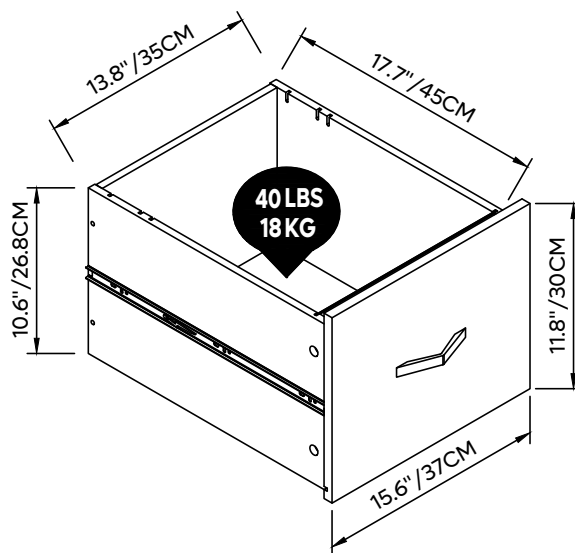
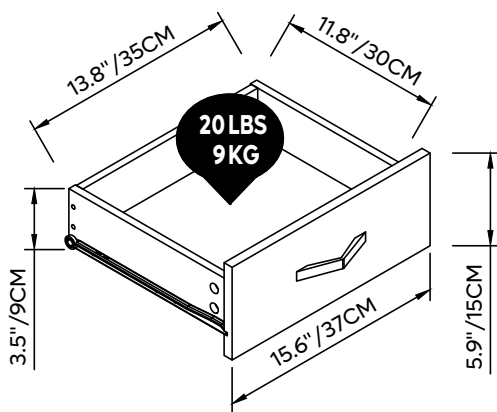
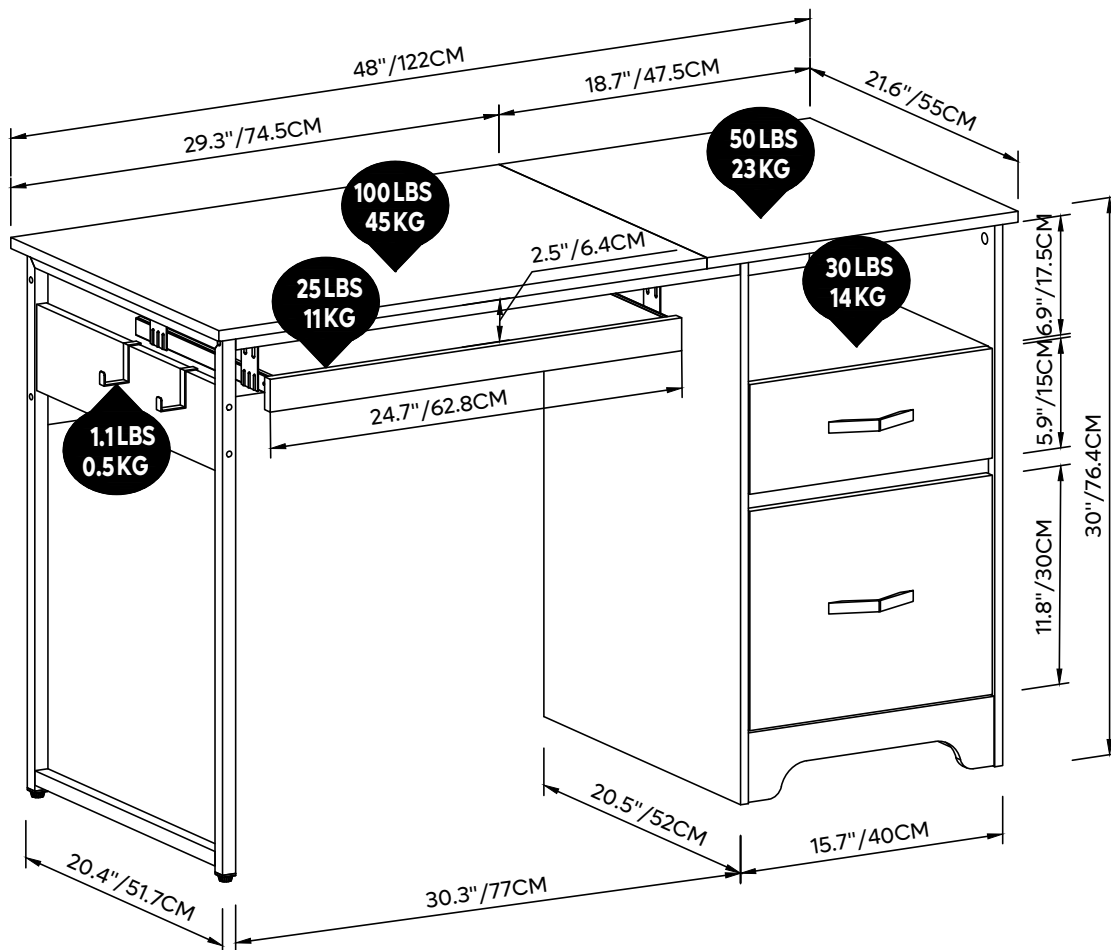

# DETAILS

DETAILS  
DÉTAILS/POINTS DE MONTAGE  
NOTE PARTICOLARI

DETALLES  
組み立てのポイント  
詳細情報

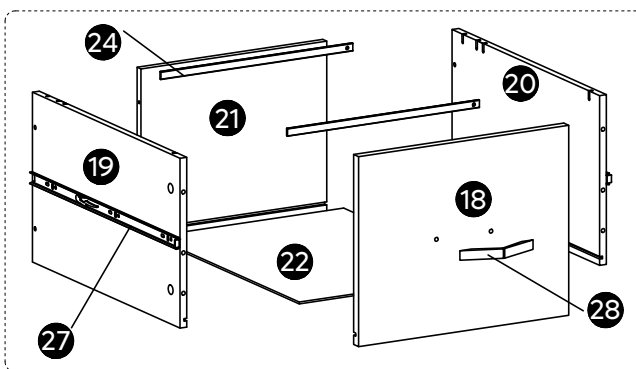
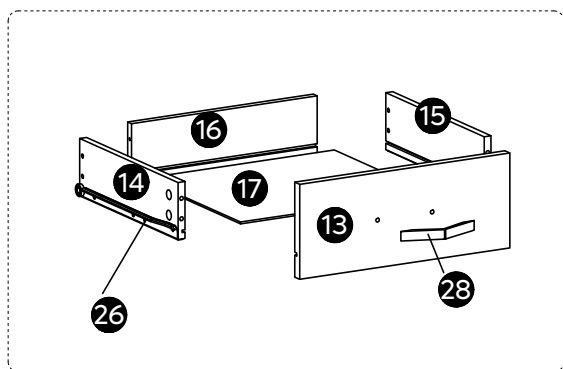
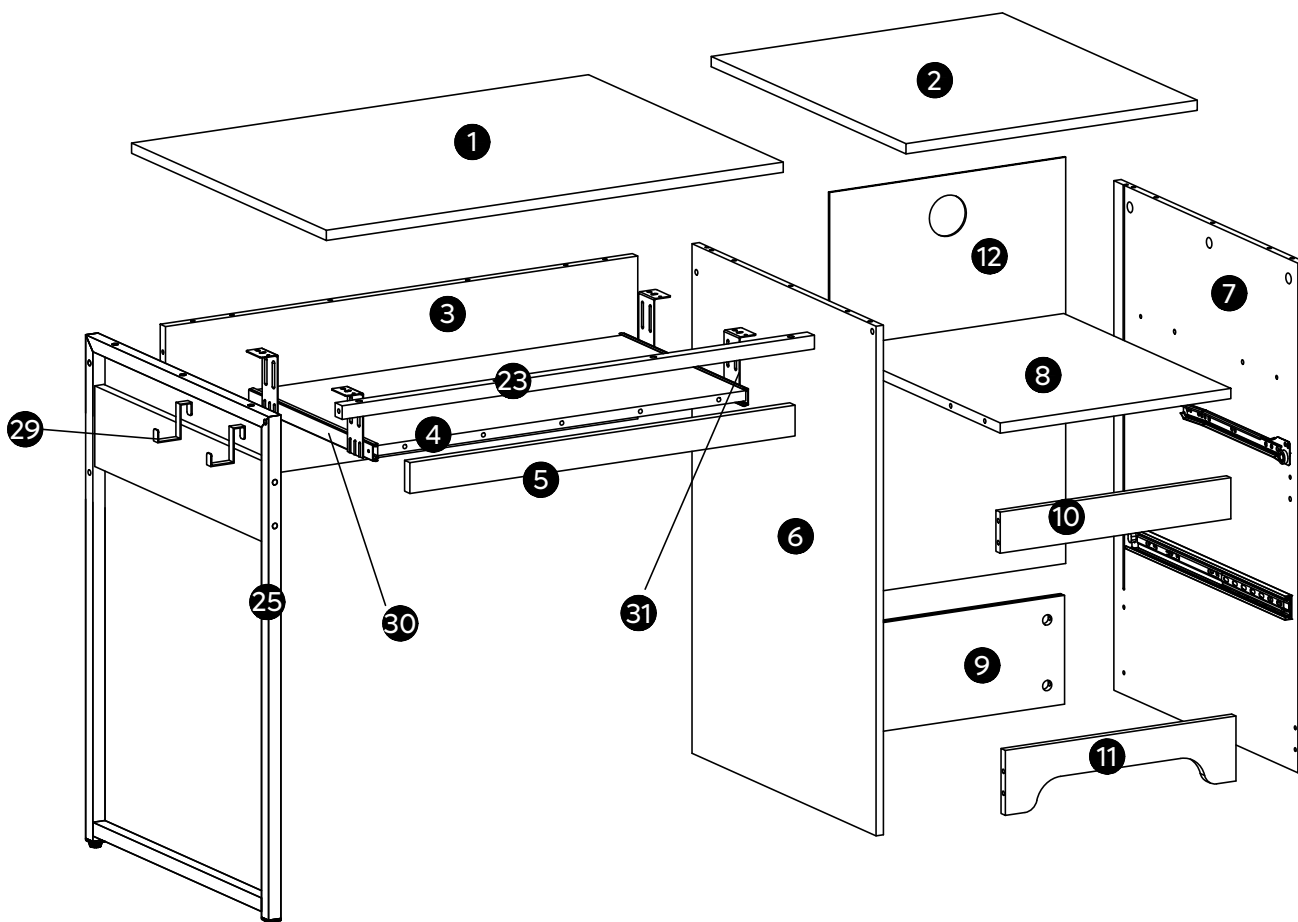

# PART LIST

STÜCKLISTE  
LISTE DES PIÈCES  
ELENCO DEI PEZZI

LISTA DE PIEZAS  
部品の確認  
部件清单

1

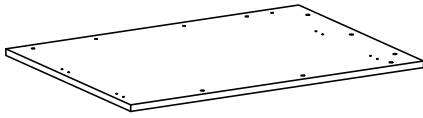

X1

2

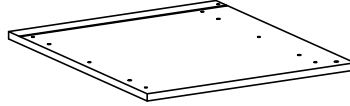

X1

3

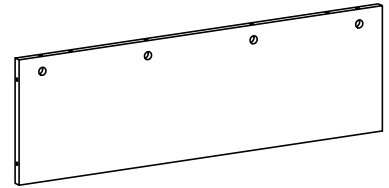

X1

4

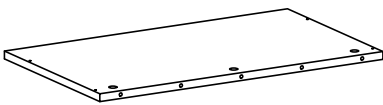

X1

5

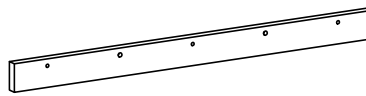

X1

6



X1

7



X1

8

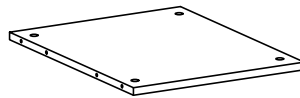

X1

9



X1

10



X1

11



X1

12

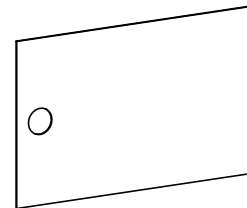

X1

13

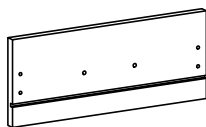

X1

14

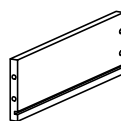

X1

15

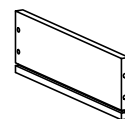

X1

# PART LIST

STÜCKLISTE  
LISTE DES PIÈCES  
ELENCO DEI PEZZI

LISTA DE PIEZAS  
部品の確認  
部件清单

16



X1

17



X1

18

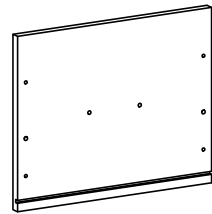

X1

19

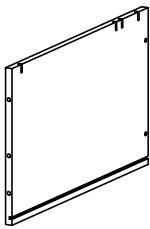

X1

20

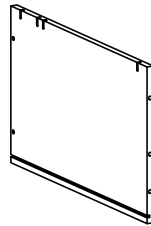

X1

21

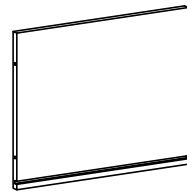

X1

22

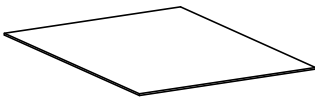

X1

23



X1

24



X2

25

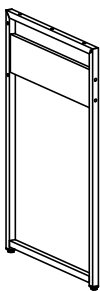

X1

26

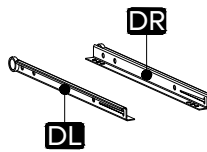

X1

27



X2

28



X2

29

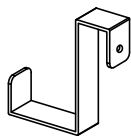

X2

30

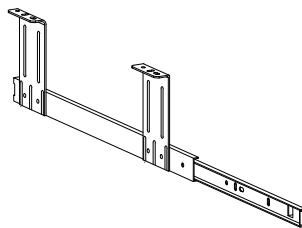

X1

31

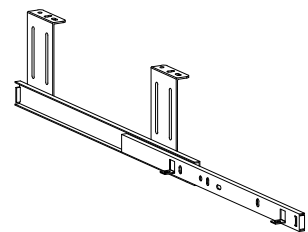





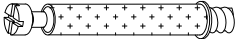

X1

# ACCESSORY LIST

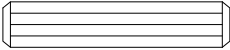
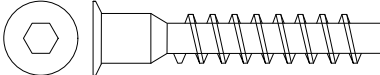
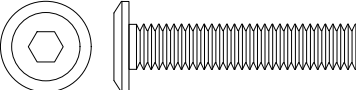
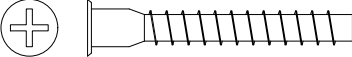
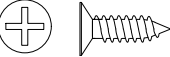
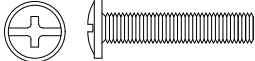
ZUBEHÖRLISTE  
LISTE DES ACCESSOIRES  
ELENCO DEGLI ACCESSORI

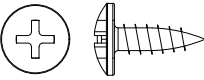
LISTA DE ACCESORIOS  
付属品部品の確認  
配件清单

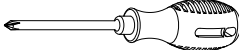
<b>A</b>	ST6x35mm	35+2	
<b>B</b>	Ø15mm	35+2	
<b>C</b>	Ø6x30mm	16+2	
<b>D</b>	ST7x38mm	4+1	
<b>E</b>	M6x30mm	9+1	
<b>F</b>	ST5x35mm	8+1	
<b>G</b>	ST3.5x12mm	14+1	
<b>H</b>	M4x20mm	4+1	
<b>I</b>		4+1	
<b>J</b>	ST4x12mm	12+1	
	M4	1	
		1	

# Detailed Installation for Accessory A B

Installation détaillée pour l'accessoire A B  
 Detaillierte Installation des Zubehörs A B  
 Installazione dettagliata per l'accessorio A B  
 Instalación detallada del accesorio A B  
 カムロック取り付け方  
 配件A、B详细安装

**1**

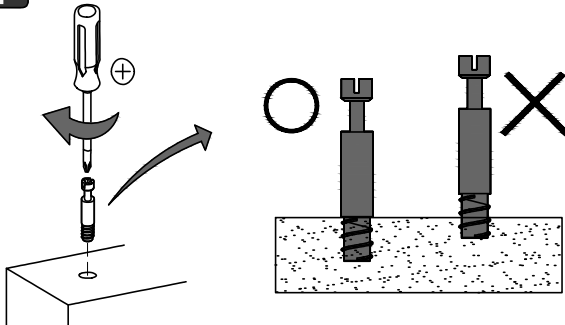

Screw cam dowel on the panel.  
 Vissez la goupille de came au panneau.  
 Nockendübel auf die Platte schrauben.  
 Avvitare il tassello a camme sul pannello.  
 tornillo de pasador de leva en el panel.  
 カムロックネジを部品に取り付ける。  
 螺杆用十字螺丝刀装入对应的预留孔内

Place another panel via the dowel.  
 Placez un autre panneau par le goujon.  
 Setzen Sie eine weitere Platte über den Dübel ein.  
 Posizionare un altro pannello tramite il tassello.  
 Coloque otro panel a través del pasador.  
 カムロックネジをカムロック穴に差し込む。  
 螺杆插入对应孔位，将两块板材对接起来。

**2**

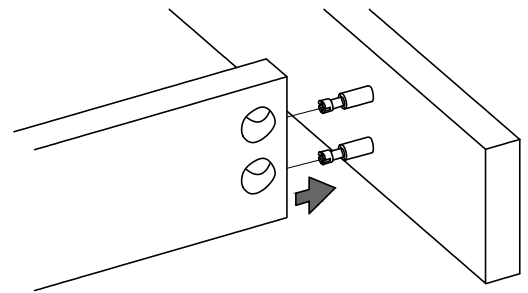

**3**

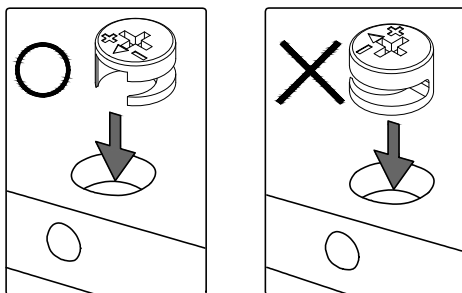

Pay attention to the direction of cam lock when putting it into hole.

Faites attention à la direction du verrou à came en entrant dans le trou.

Achten Sie auf die Richtung des Nockenschlosses, wenn Sie es in das Loch stecken.

Fare attenzione alla direzione della serratura a camme quando lo si inserisce nel foro.

Preste atención a la dirección de la leva de fijación al insertarla en el orificio.

カムロックネジの方向にカムロックの穴の穴の向きを合わせ取り付け。

装入锁扣圆盘，注意锁扣圆盘的方向；

Tighten up cam lock clockwise until it stops.  
 Serrez le verrou à came dans le sens des aiguilles d'une montre jusqu'à ce qu'il s'arrête.  
 Ziehen Sie die Nockenverriegelung im Uhrzeigersinn bis zum Anschlag an.  
 Stringere la serratura a camme in senso orario fino all'arresto.  
 Apriete la leva de fijación en sentido horario hasta el tope.  
 カムロックをドライバーで締め固定する。  
 顺时针旋转锁扣圆盘并锁紧。

**4**

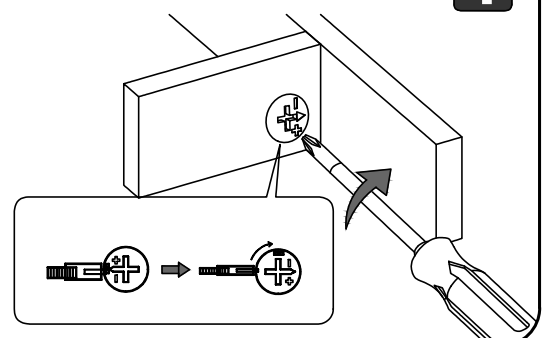

1

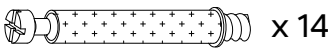
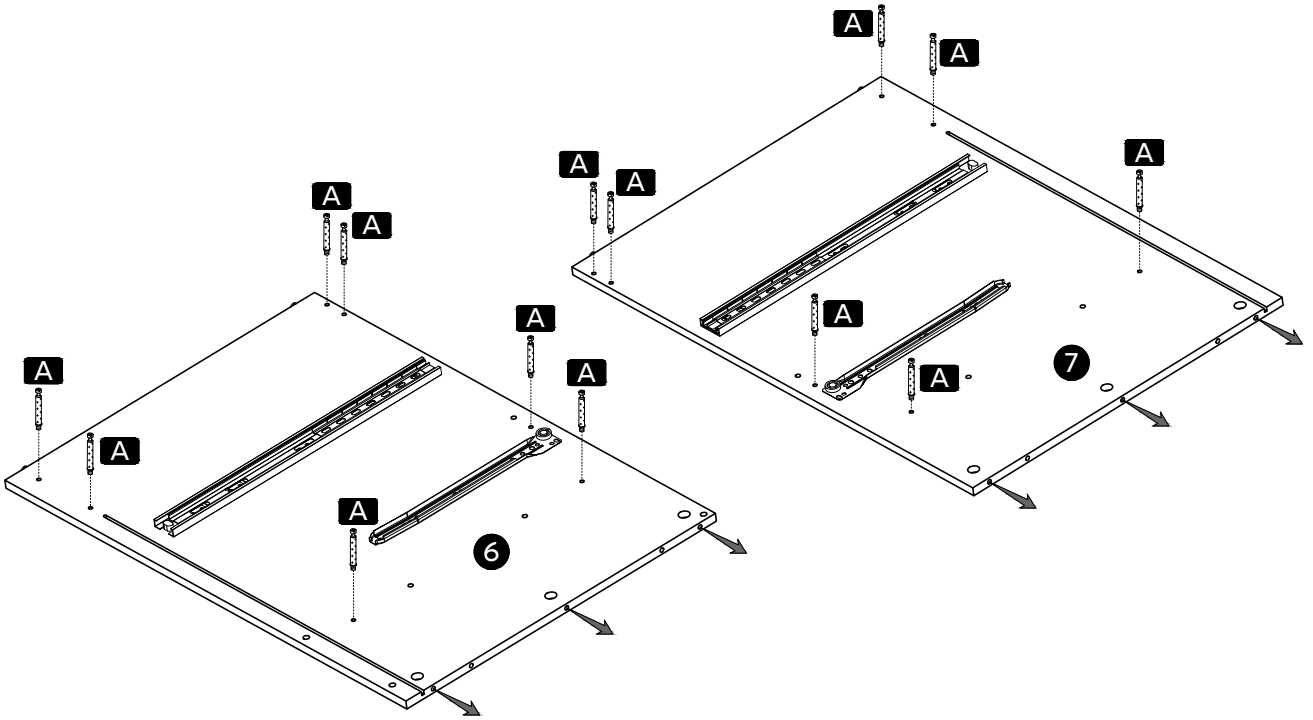

x 14

**A** ST6x35mm

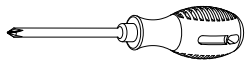

2

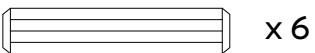
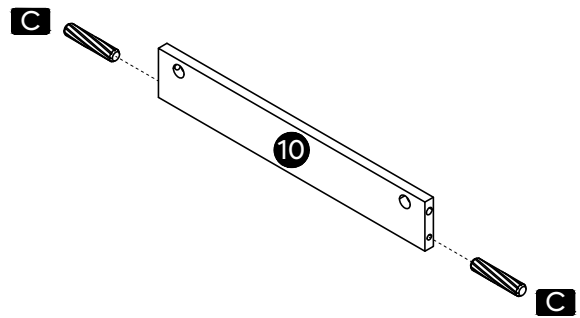
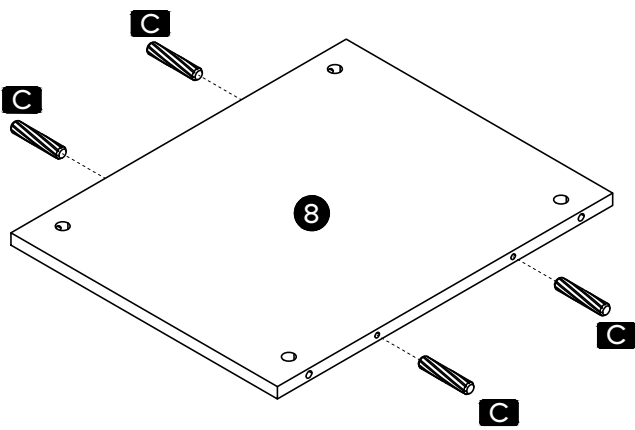

x 6

**C** Ø6x30mm

10

H104612N

### 3

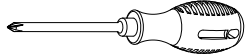
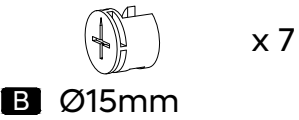
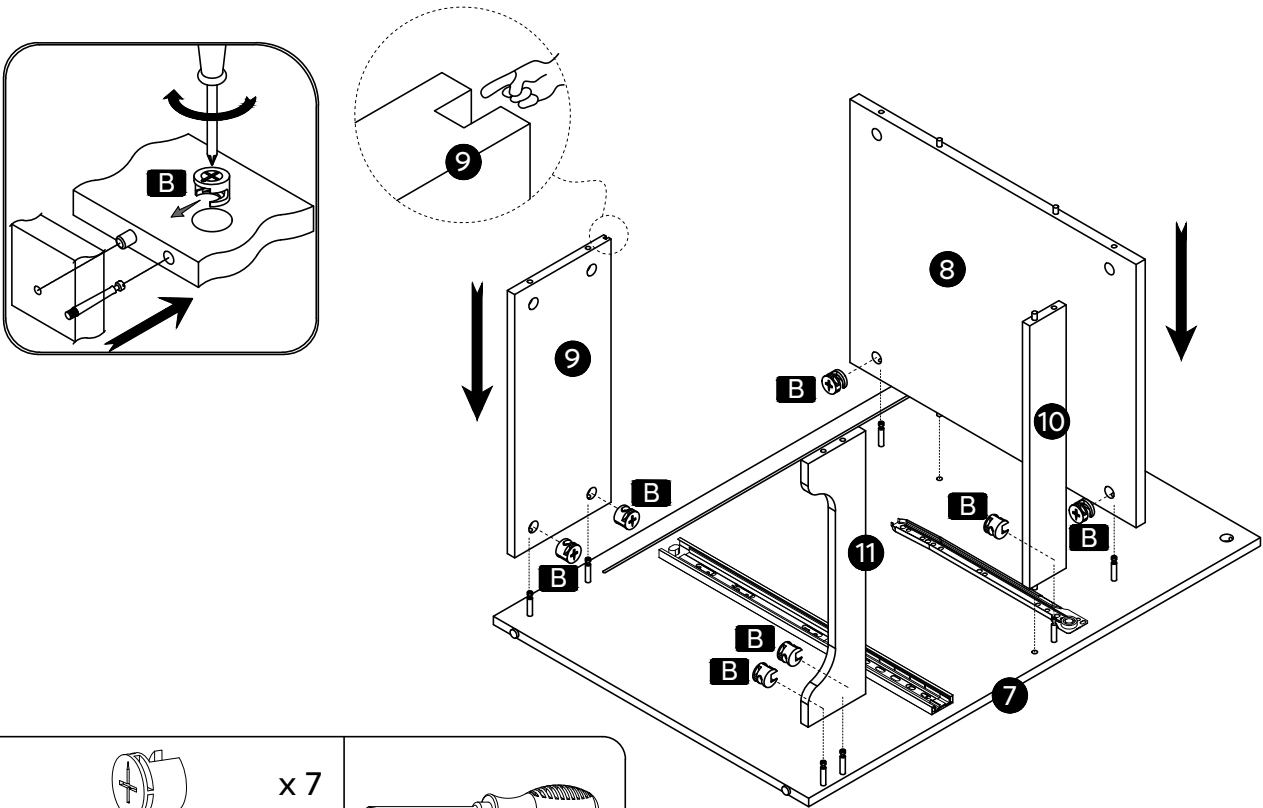

### 4

- ※ Two persons are needed.
- ※ Deux personnes sont nécessaires.
- ※ Zwei Personen sind erforderlich.
- ※ Sono necessarie due persone.
- ※ Se necesitan dos personas.
- ※ 必ず2人で作業してください。
- ※ 需要2个人协助。

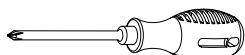
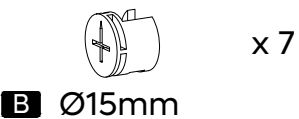
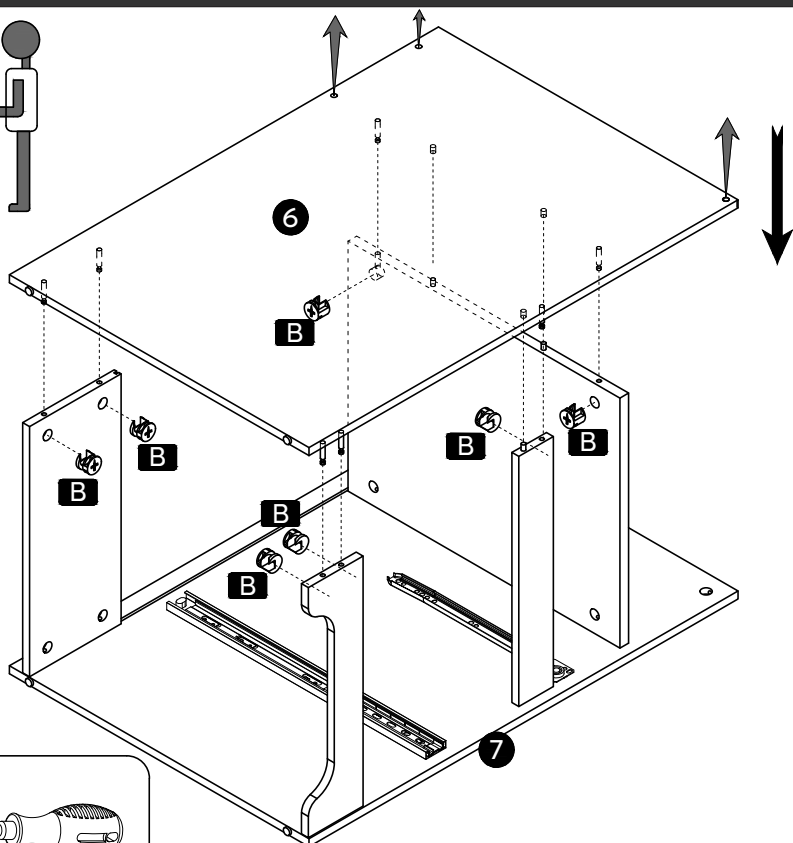
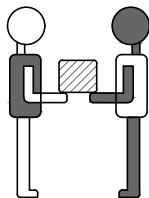

# 5



Turn over  
Retournement  
Umdrehen  
Capovolgere  
Girar  
反転する  
翻转过来

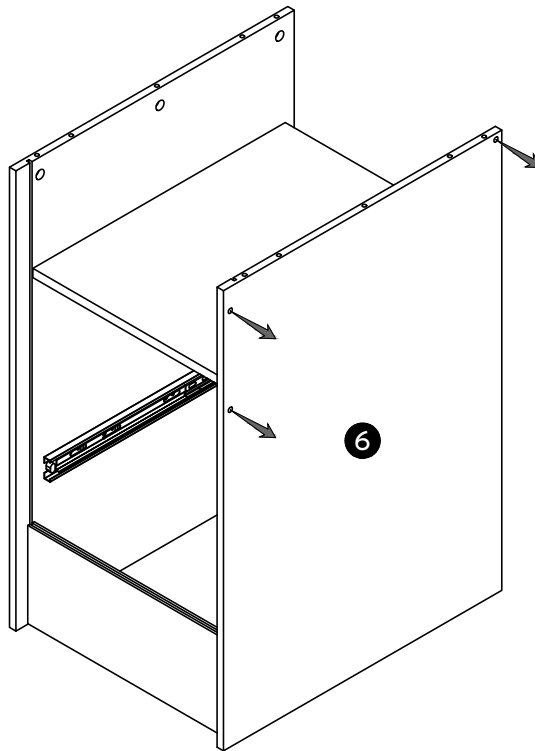

※ Back view.  
※ Vue arrière.  
※ Rückansicht.  
※ Vista posteriore.  
※ Vista trasera.  
※ バックビュー。  
※ 背视图。

# 6

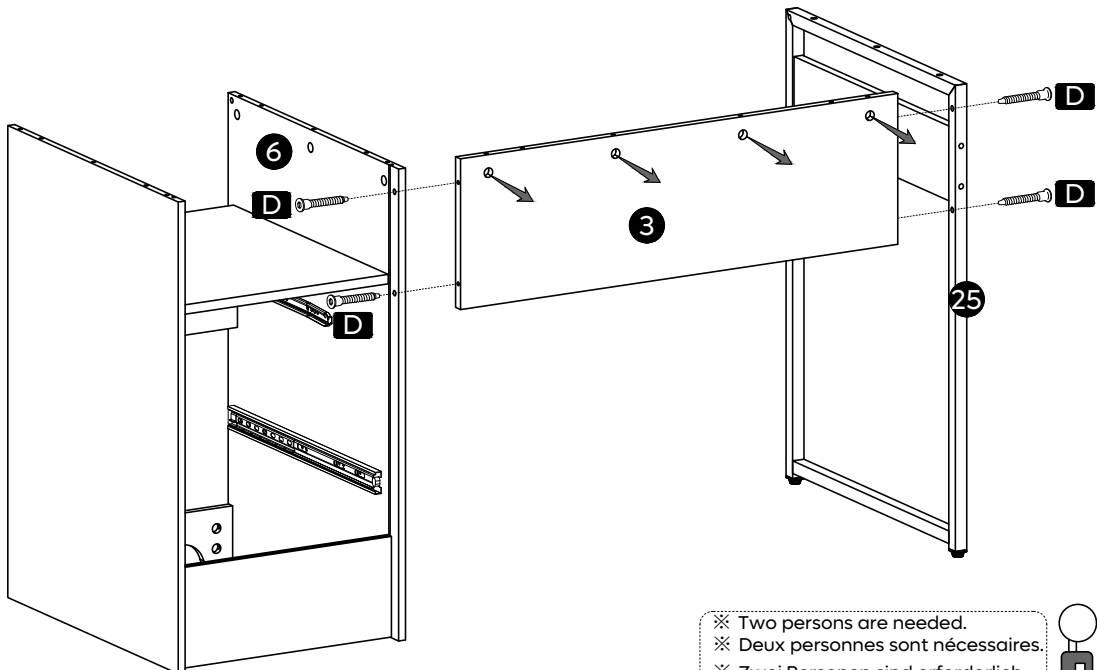

※ Two persons are needed.  
※ Deux personnes sont nécessaires.  
※ Zwei Personen sind erforderlich.  
※ Sono necessarie due persone.  
※ Se necesitan dos personas.  
※ 必ず2人で作業してください。  
※ 需要2个人协助。

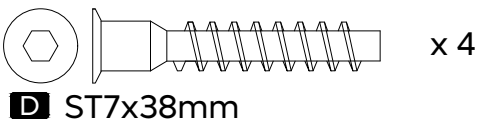
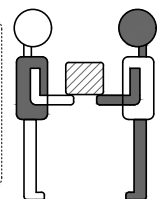

7

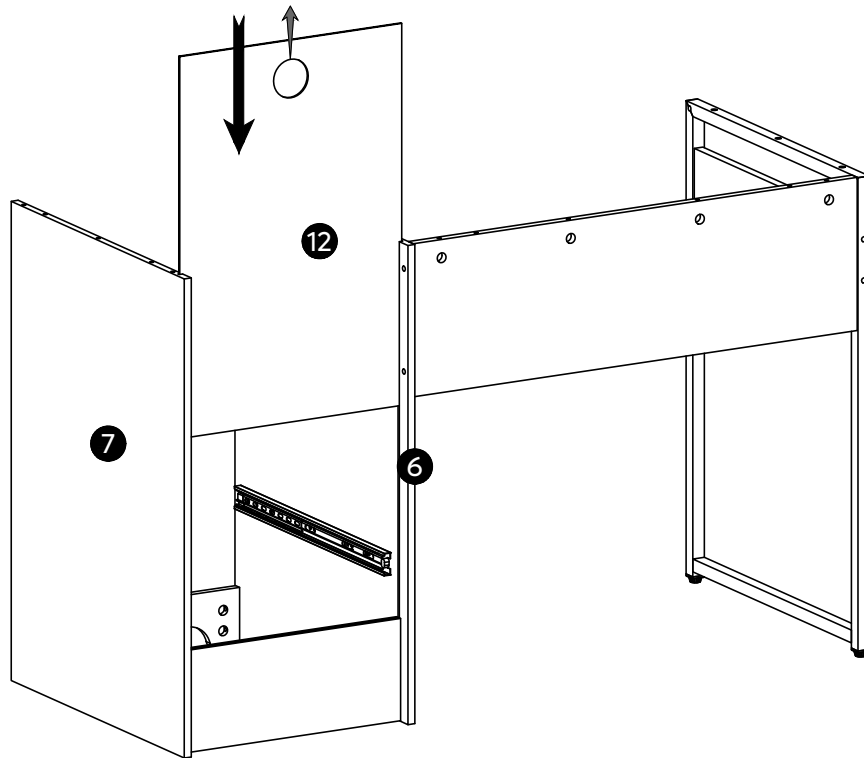

8

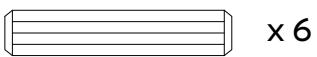
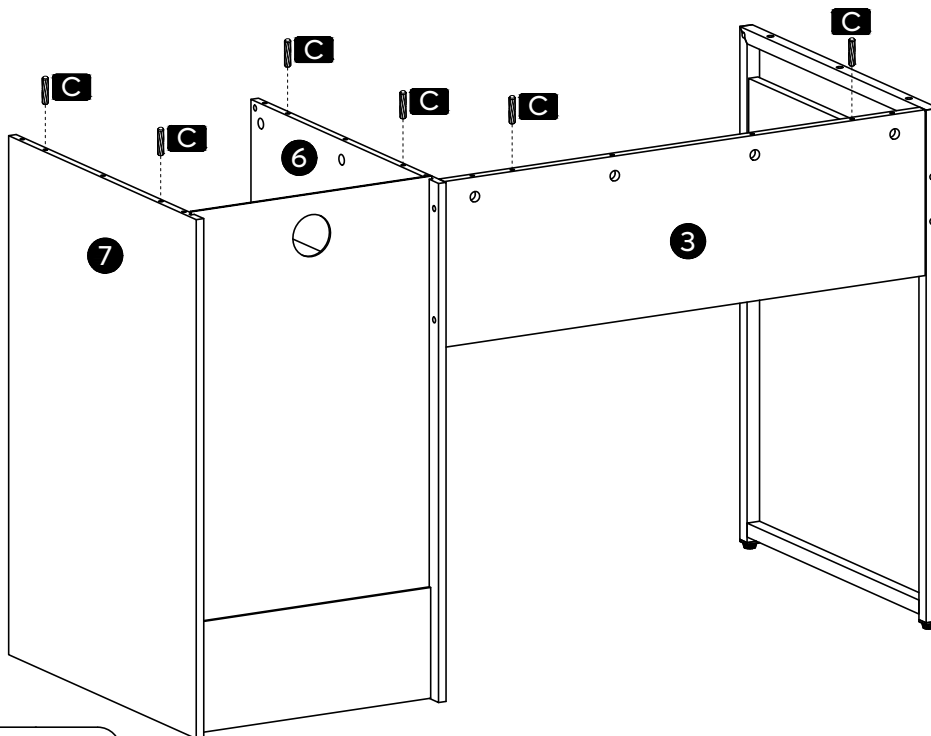

**C** Ø6x30mm

H104612N

9

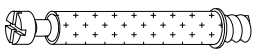
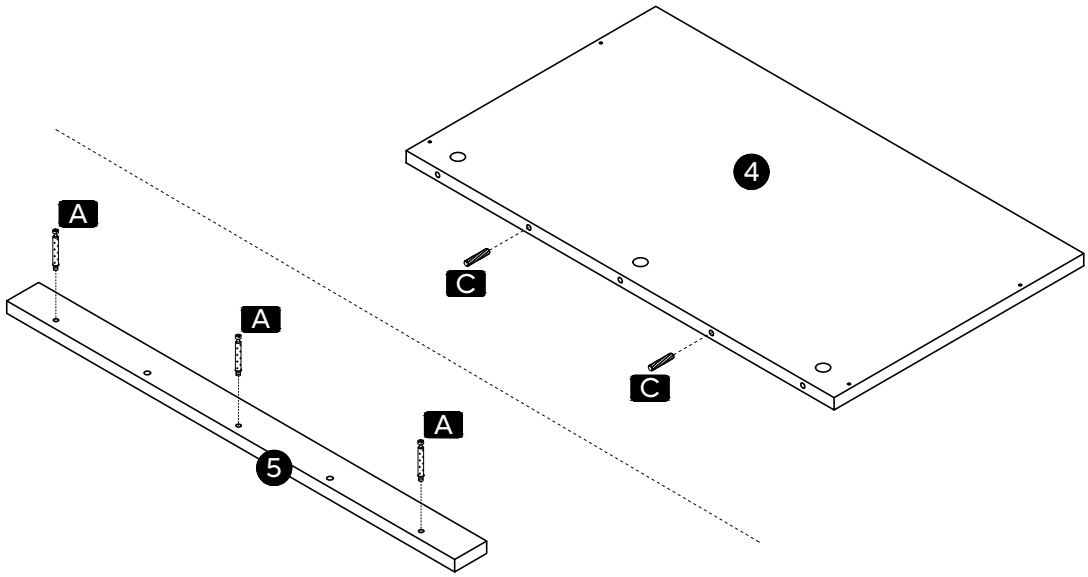

x 3

**A** ST6x35mm

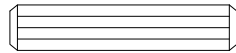

x 2

**C** Ø6x30mm

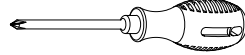

10

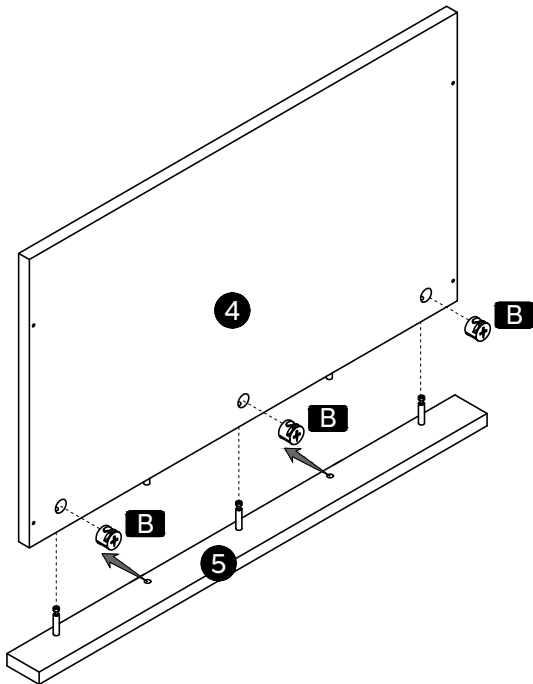

x 3

**B** Ø15mm

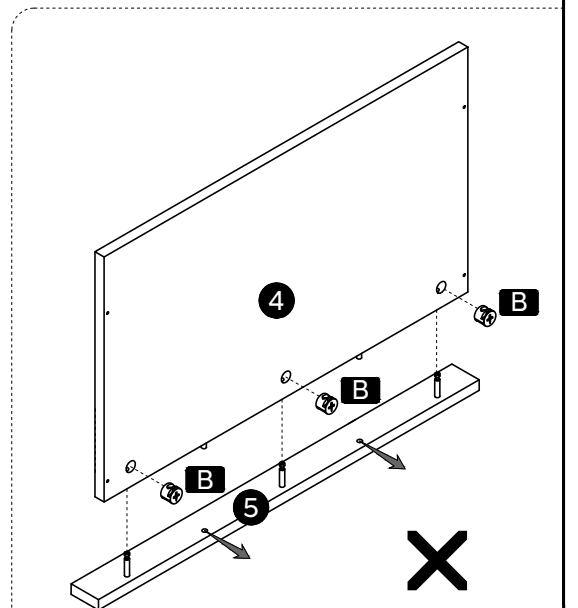
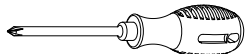

11

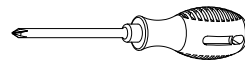
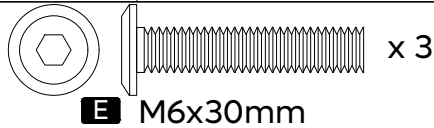
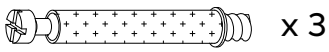
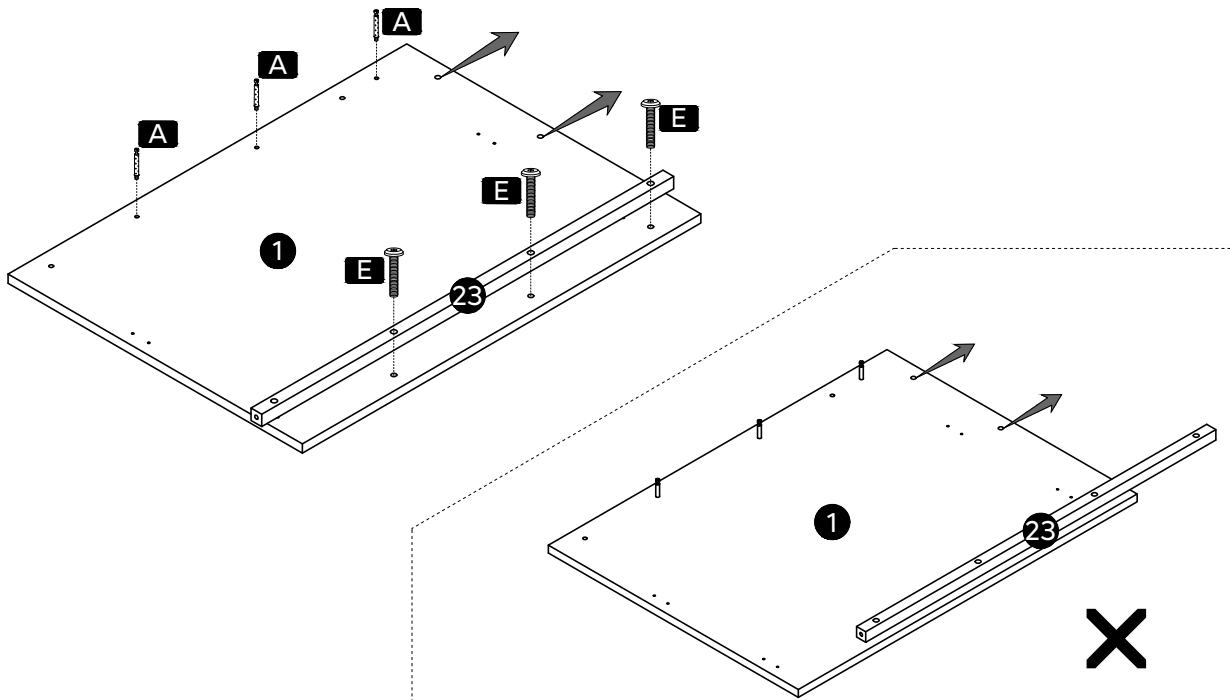

12

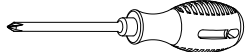
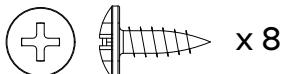
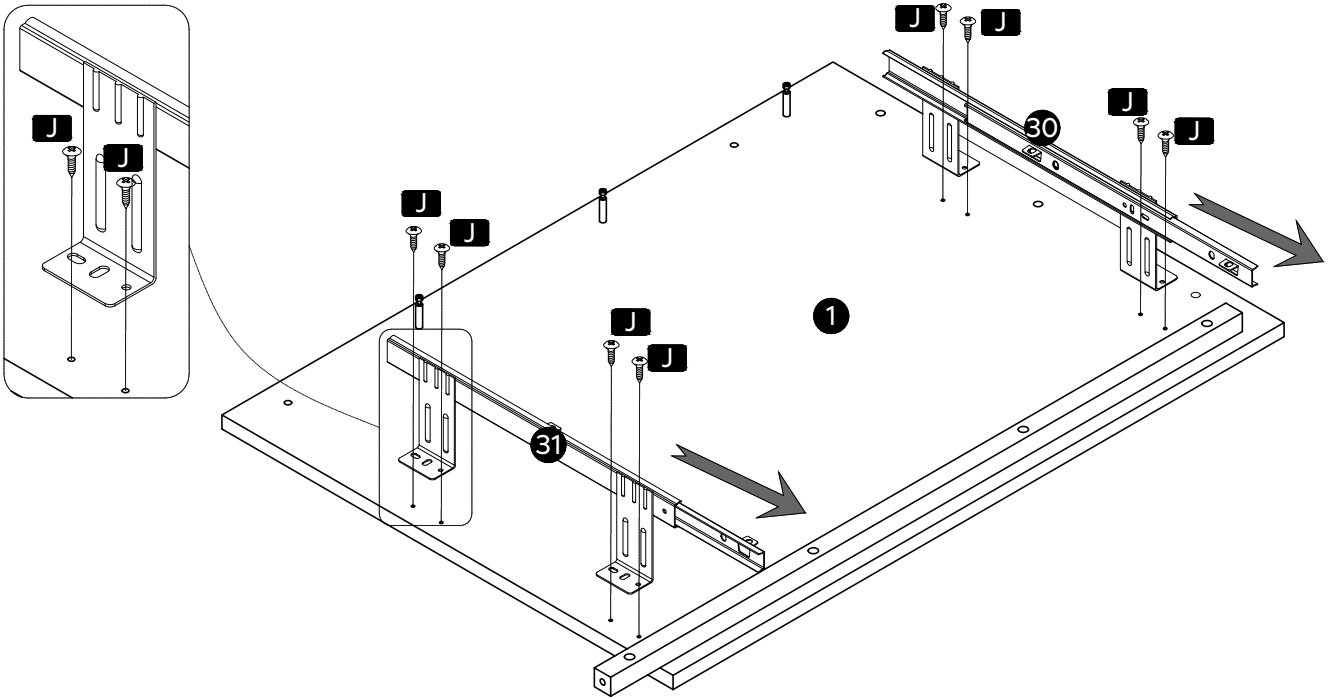

H104612N

15

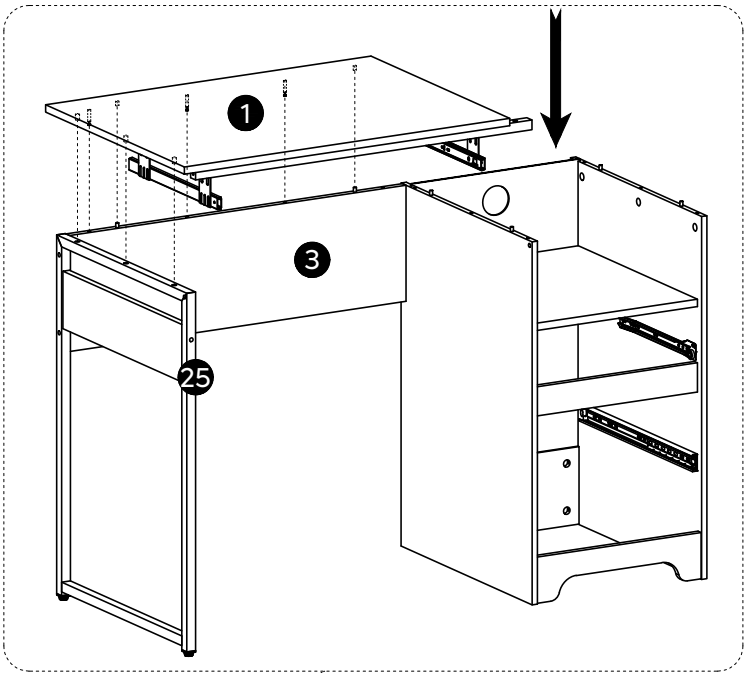
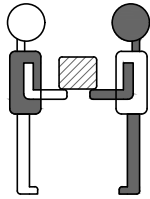

# 13

- ※ Two persons are needed.
- ※ Deux personnes sont nécessaires.
- ※ Zwei Personen sind erforderlich.
- ※ Sono necessarie due persone.
- ※ Se necesitan dos personas.
- ※ 必ず2人で作業してください。
- ※ 需要2个人协助。

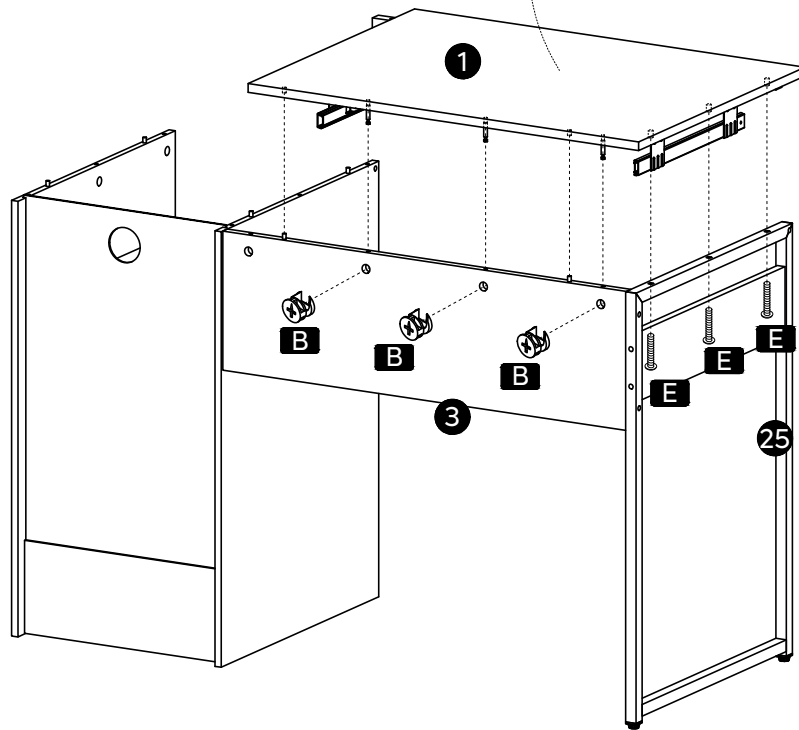

80% tighten  
80 % serré  
80% festziehen  
Serraggio al 80%  
80 % reforzado  
80%締め付け  
80%锁紧

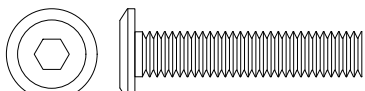
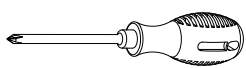

 <p><b>B</b> Ø15mm x 3</p>	 <p><b>E</b> M6x30mm x 3</p>		
---	---	---	---

14

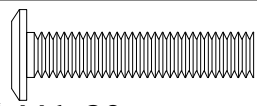
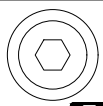
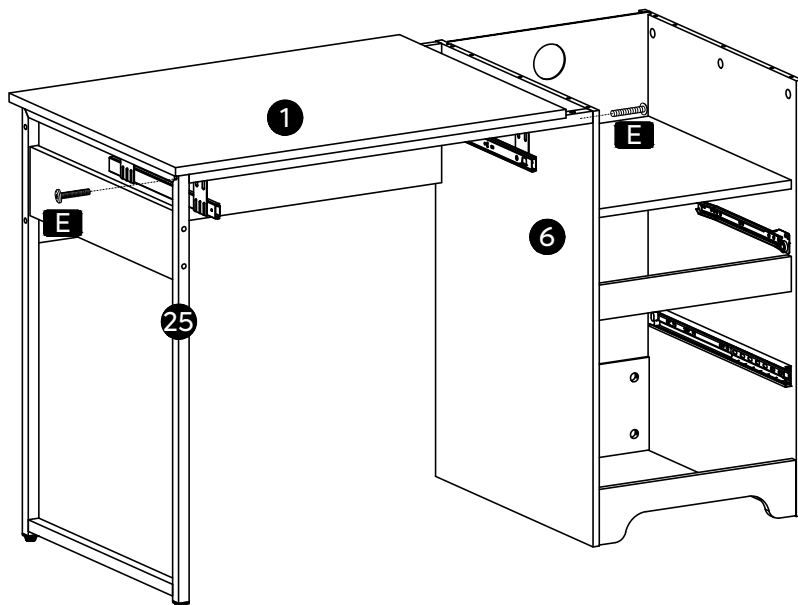

x 2



**E** M6x30mm

15

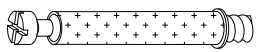
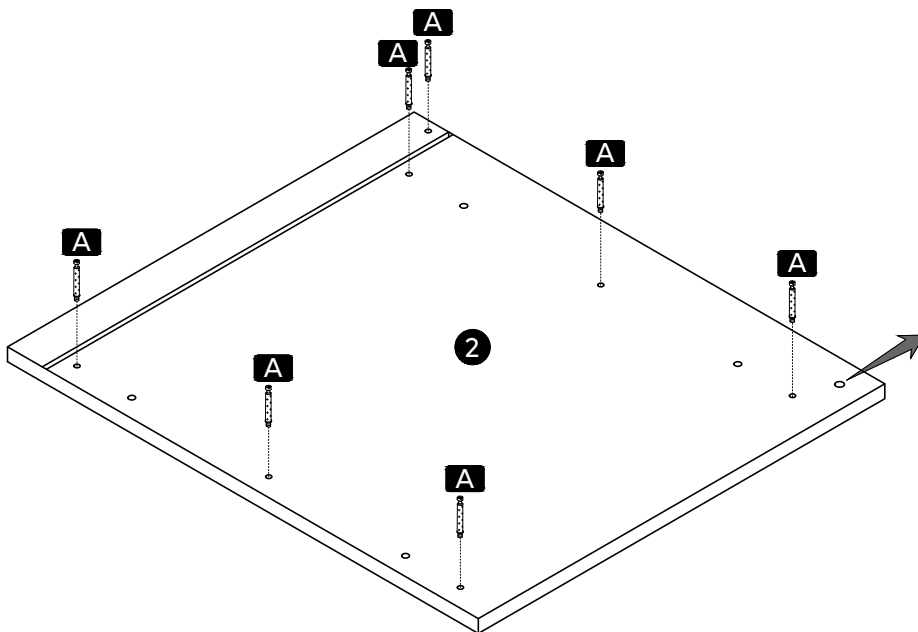

x 7

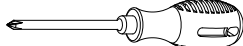



**A** ST6x35mm

H104612N

17

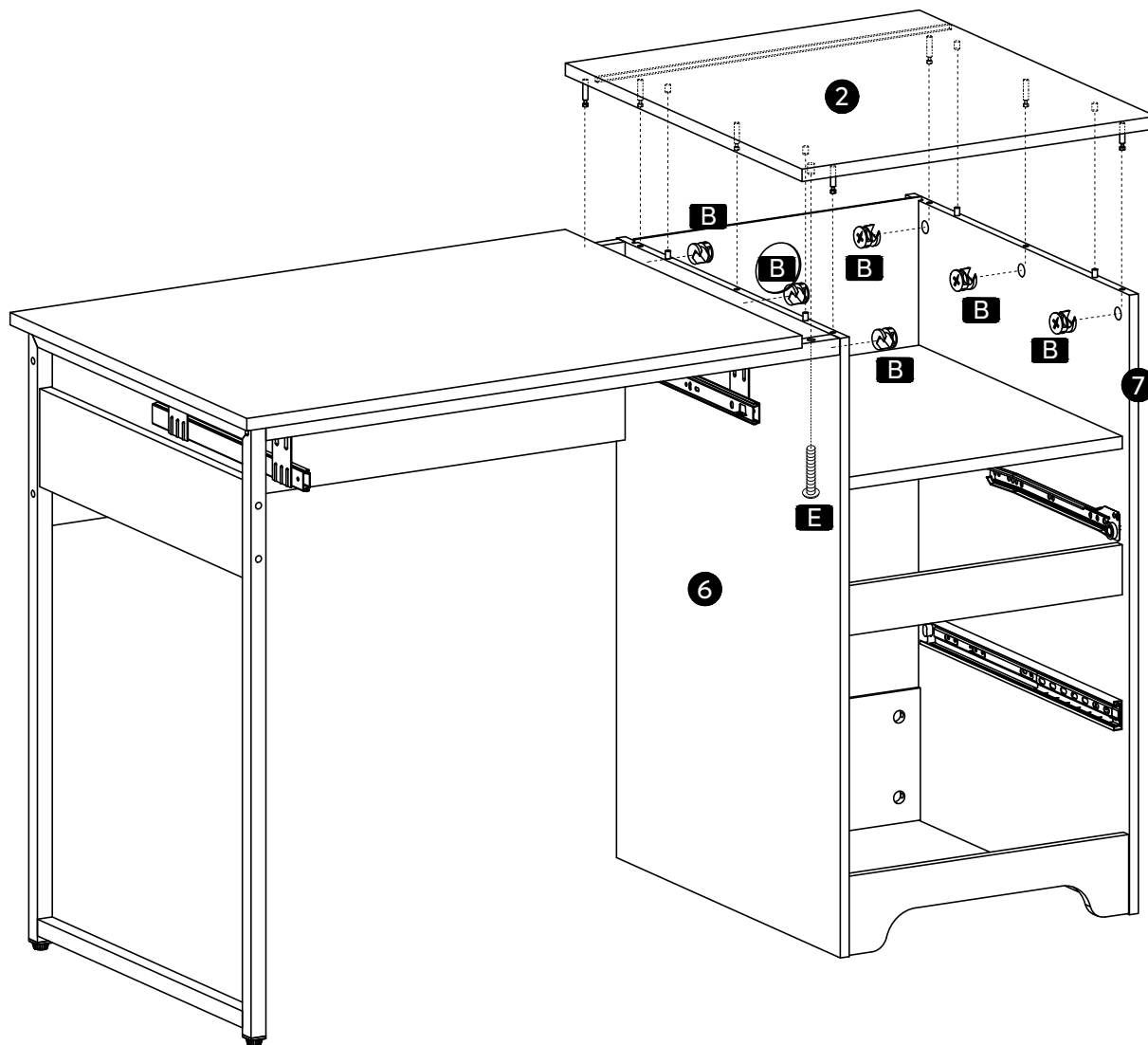

 100% tighten  
 100 % serré  
 100% festziehen  
 Serraggio al 100%  
 100 % reforzado  
 100%締め付け  
 100%锁紧

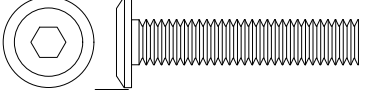

 x 6  
**B** Ø15mm

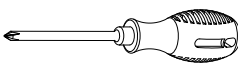

 x 1  
**E** M6x30mm



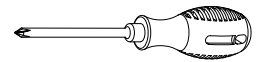
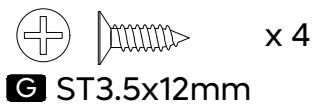
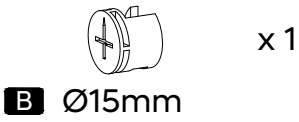
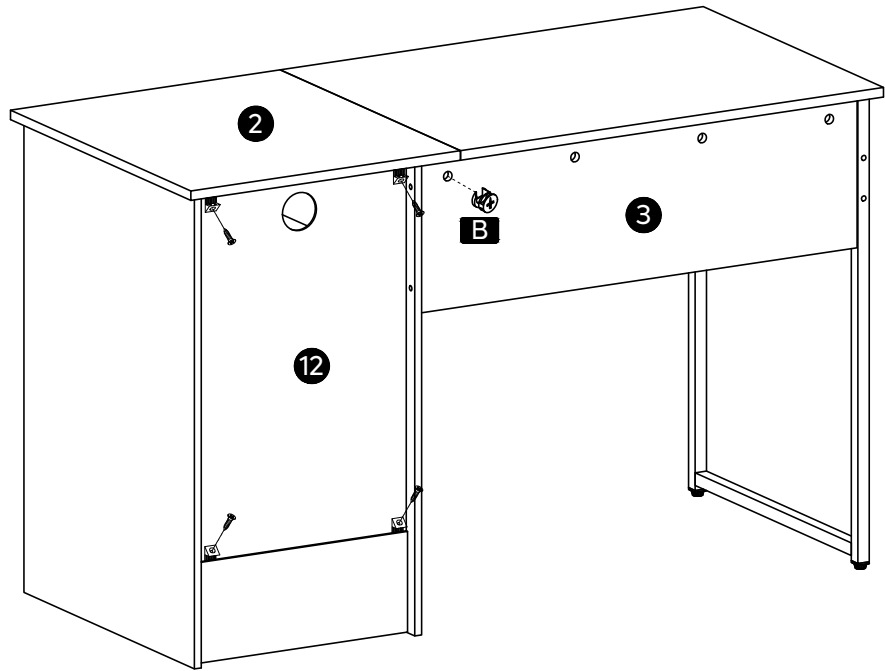
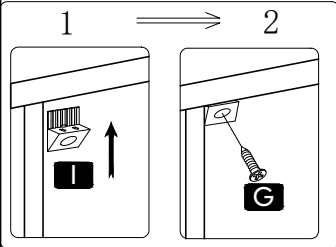

# 17

- ※ Back view.
- ※ Vue arrière.
- ※ Rückansicht.
- ※ Vista posteriore.
- ※ Vista trasera.
- ※ バックビュー。
- ※ 背视图。



# 18

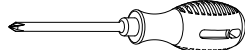
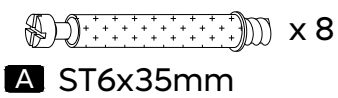
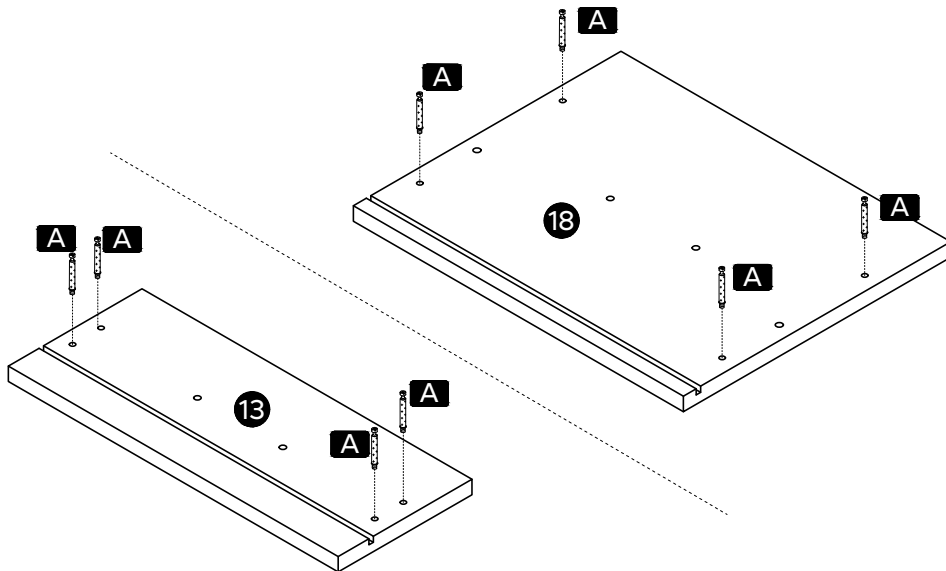

19

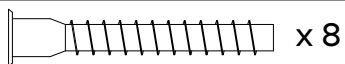
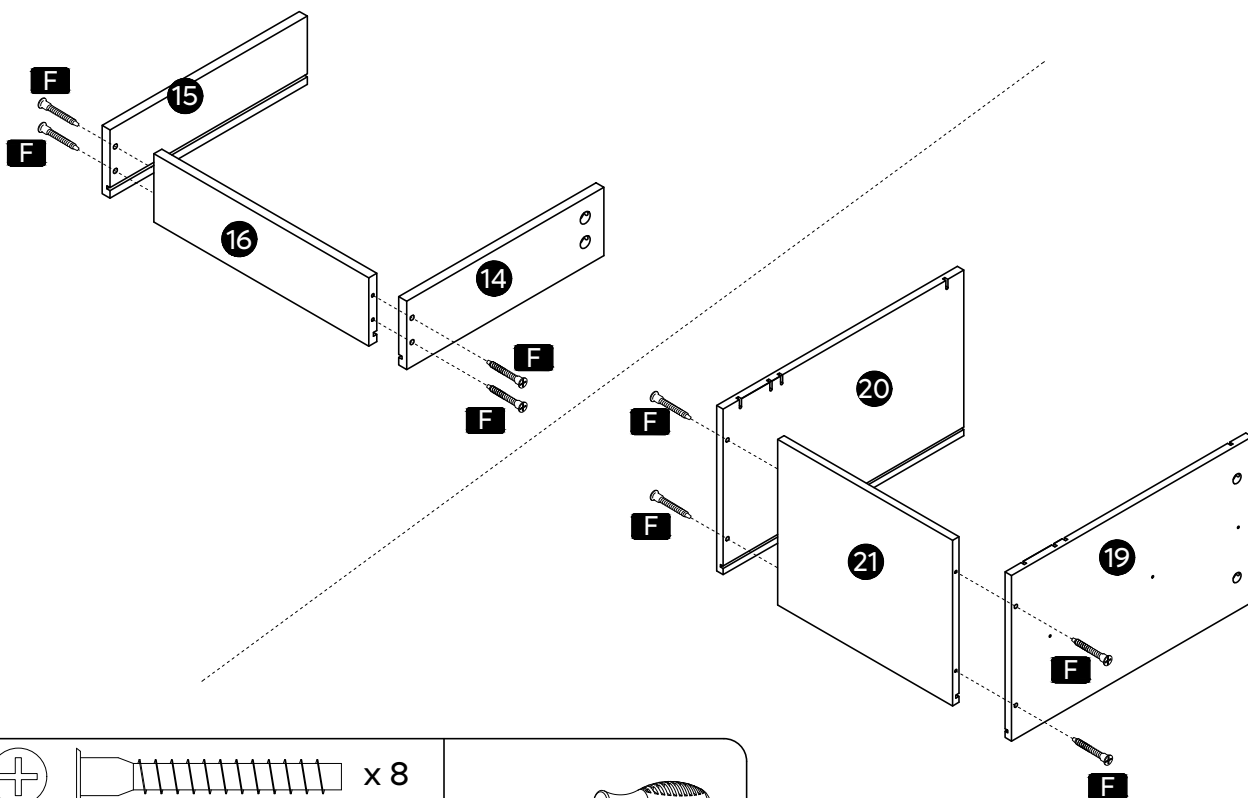

**F** ST5x35mm

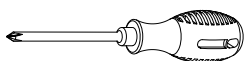

20

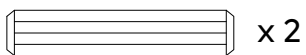
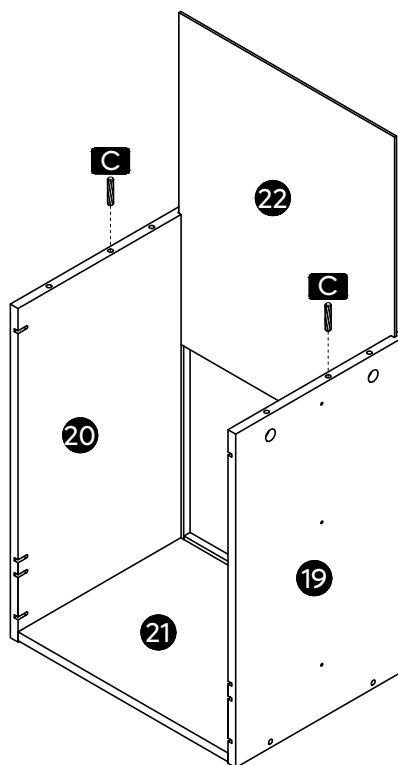
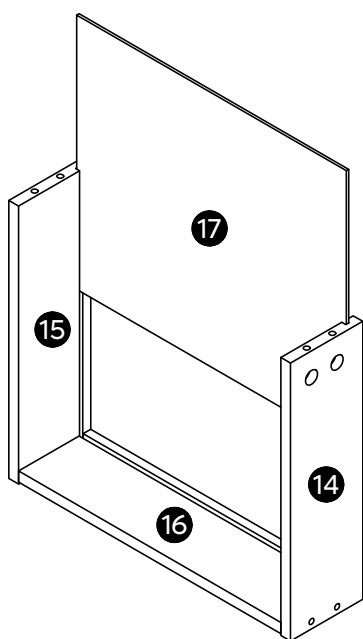

**C** Ø6x30mm

20

H104612N

21

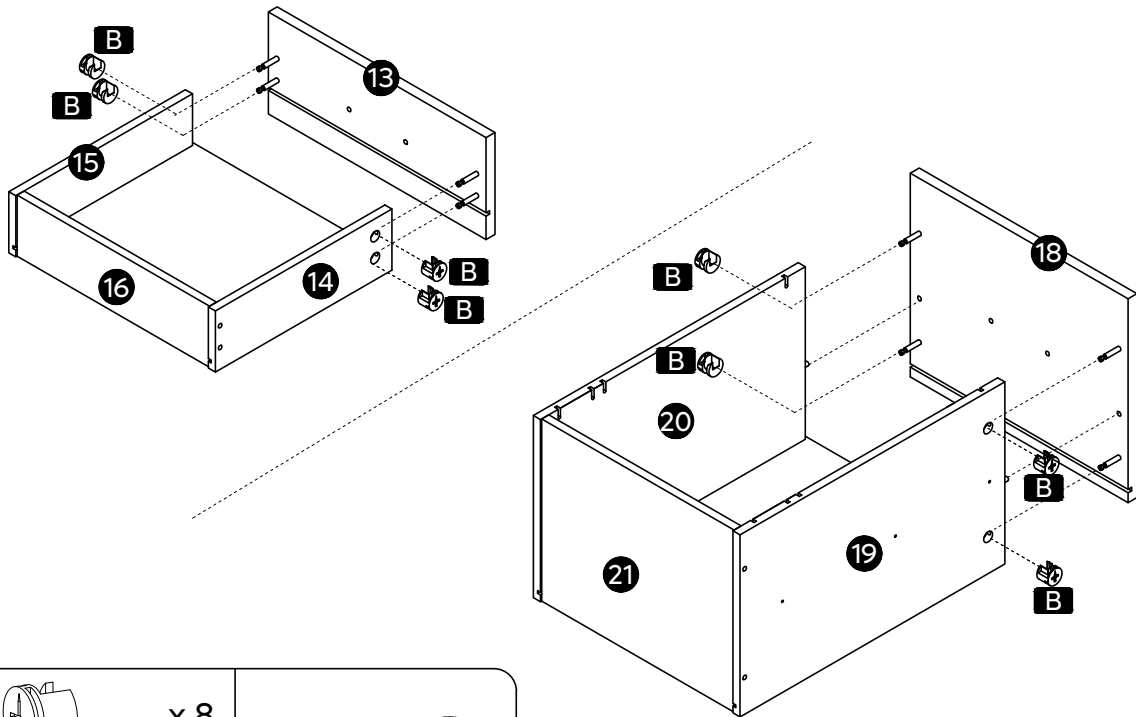

x 8

**B** Ø15mm

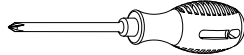

22

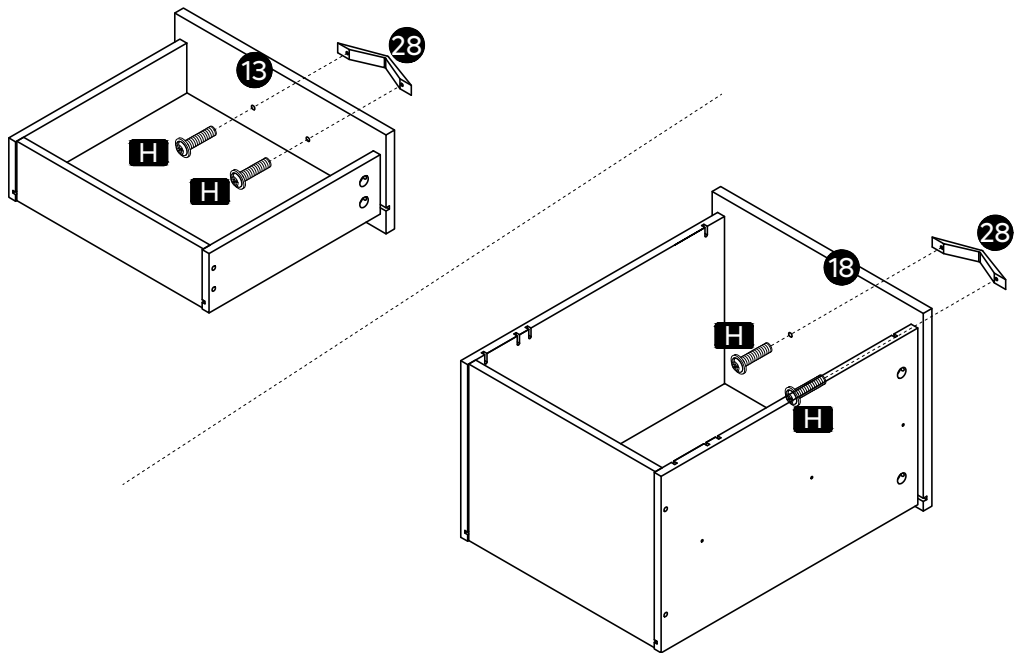

x 4

**H** M4x20mm

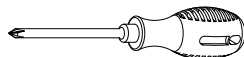

H104612N

21

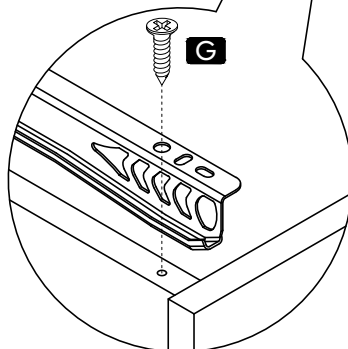
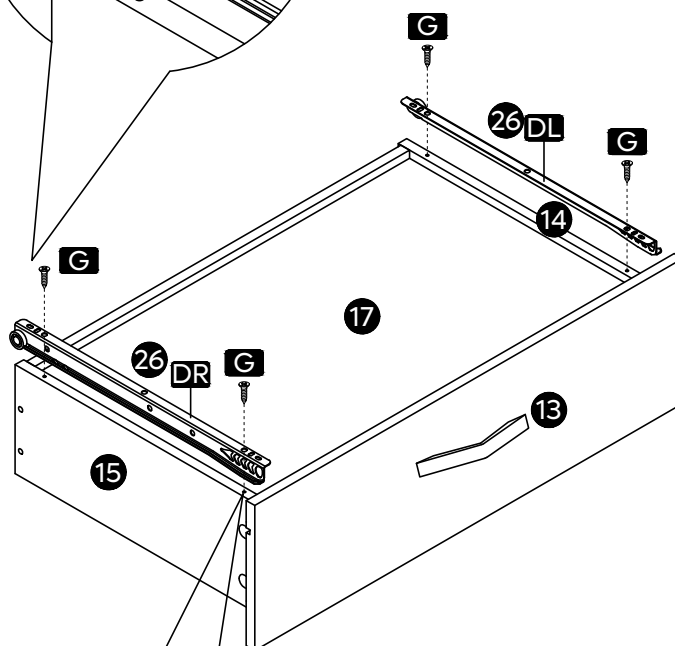
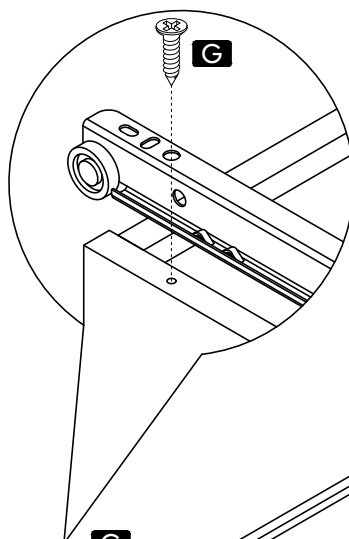
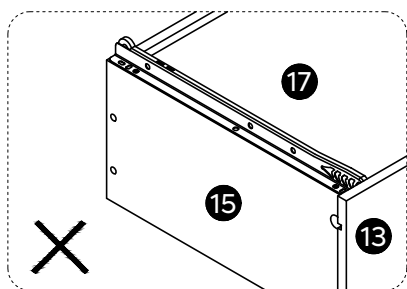
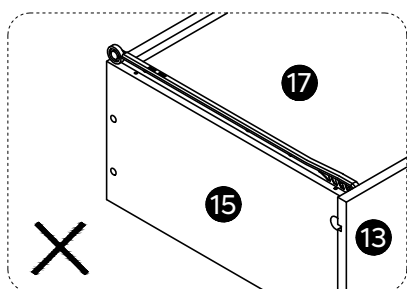
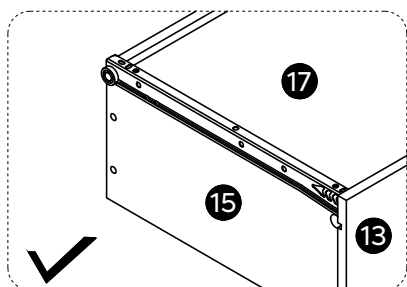

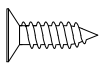

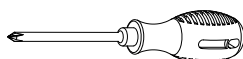
 x 4  
**G** ST3.5x12mm

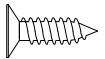
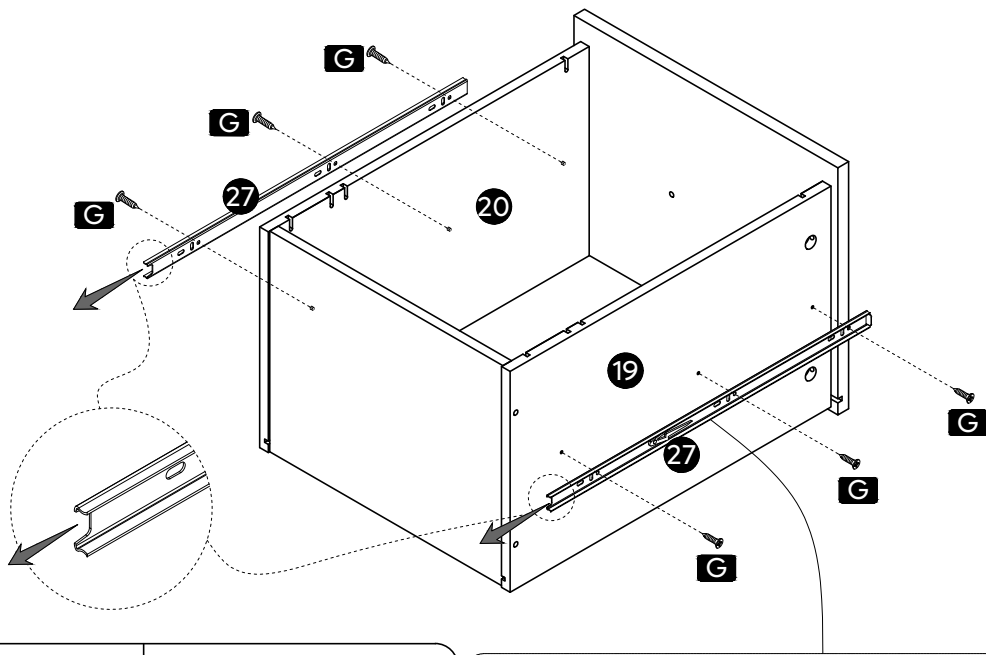

24



x 6

G ST3.5x12mm

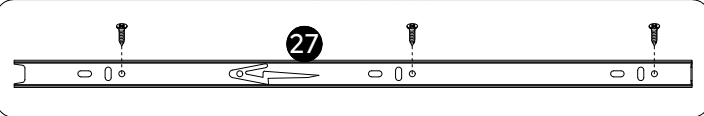
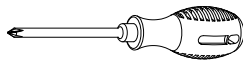

25

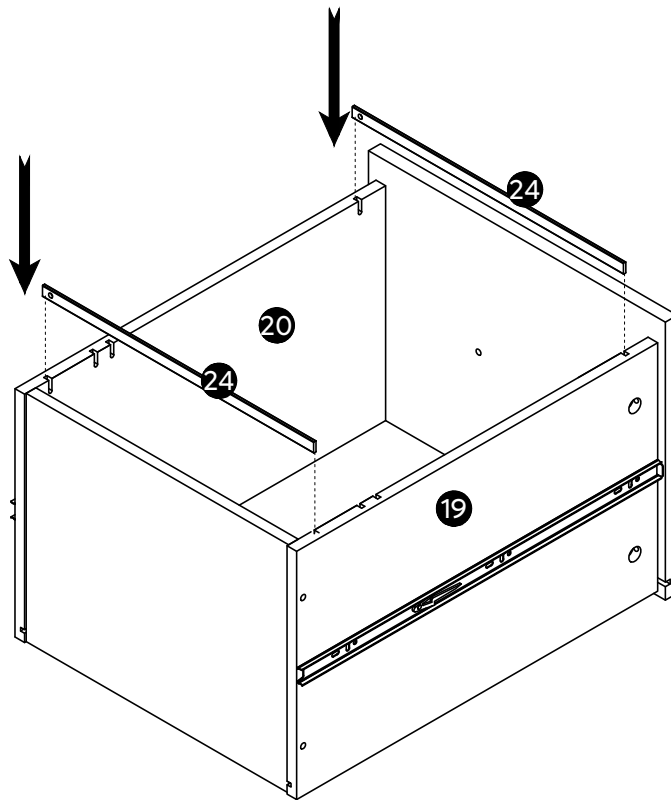

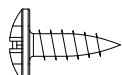
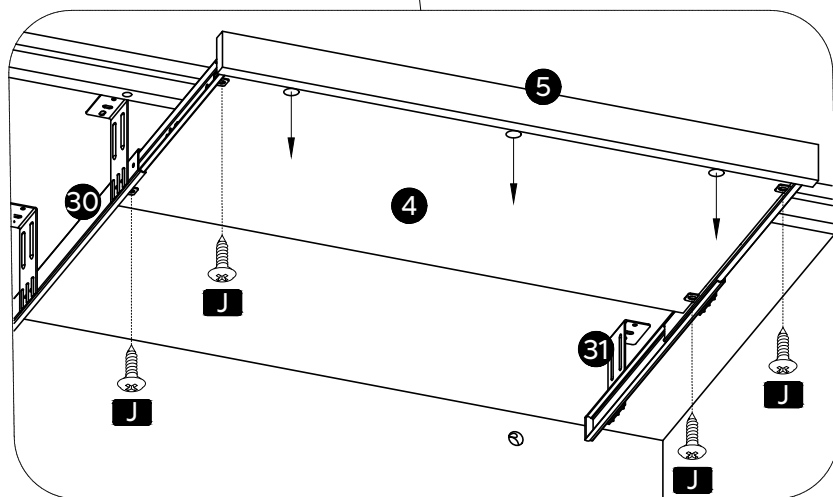
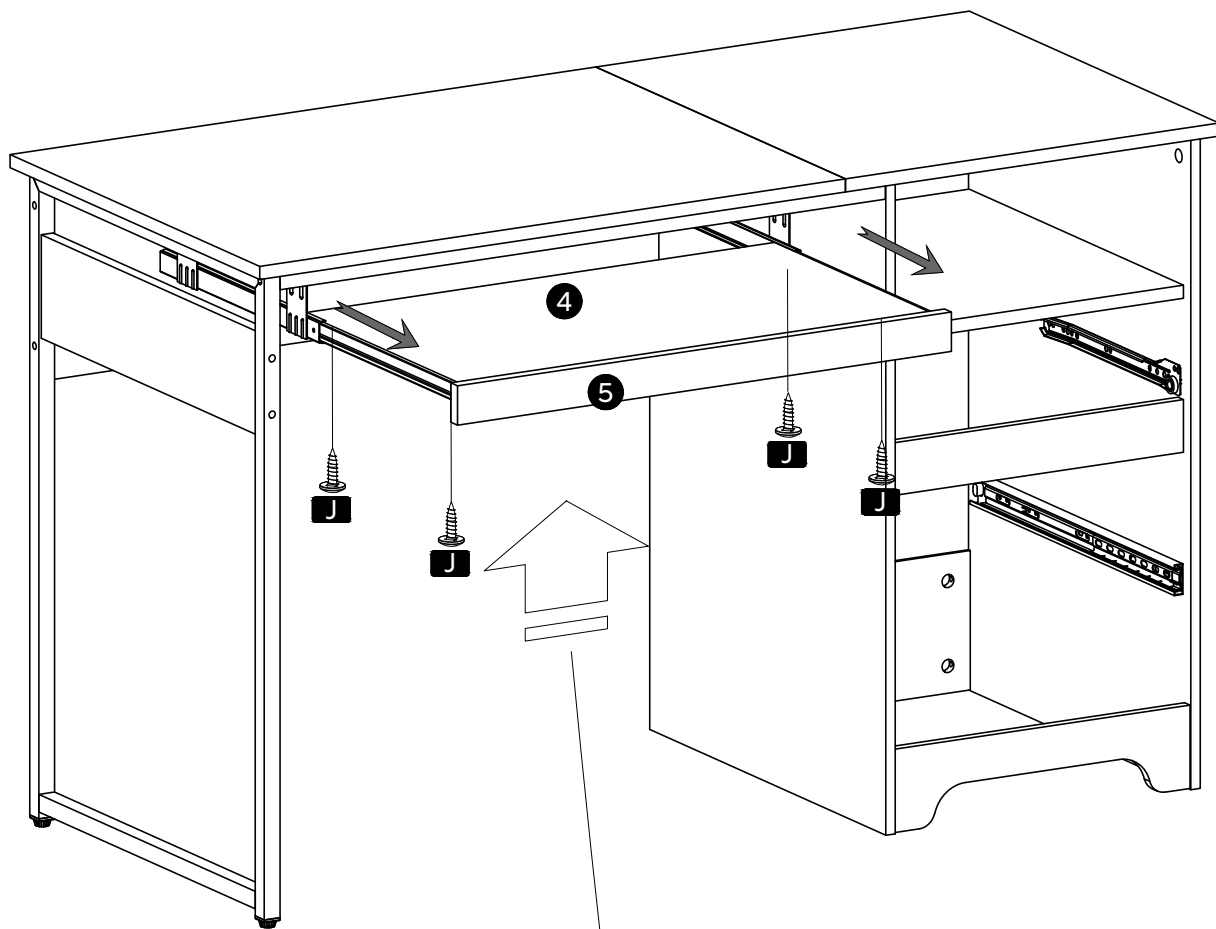

x 4

**J** ST4x12mm

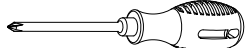

27

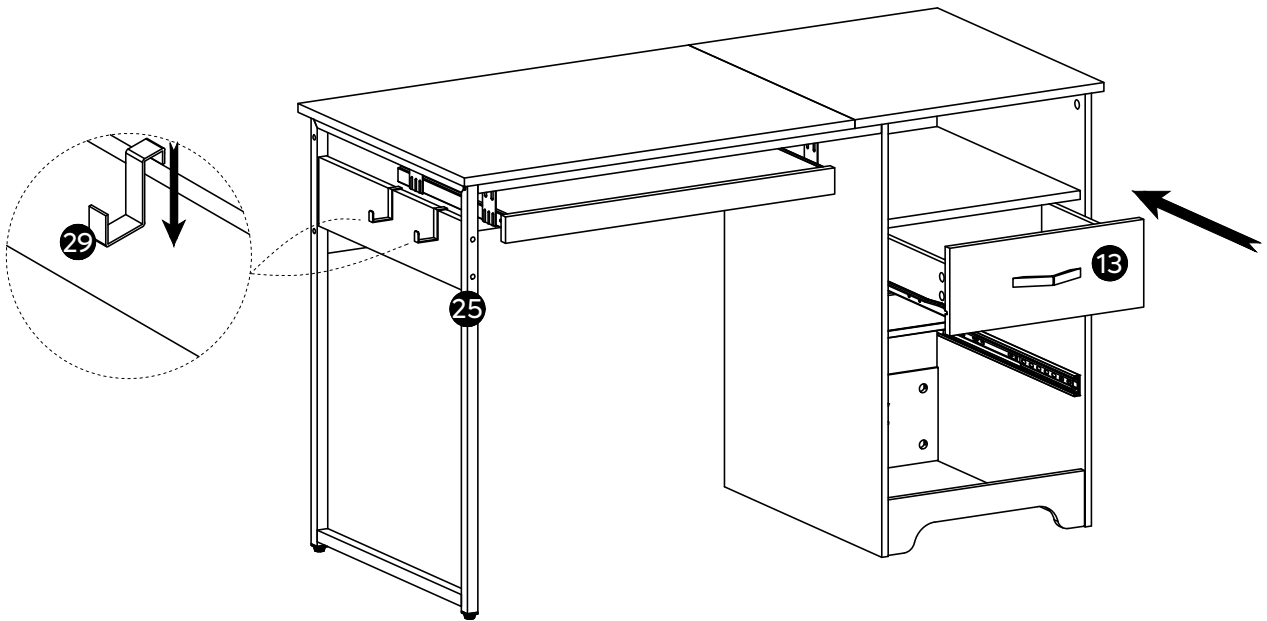

28

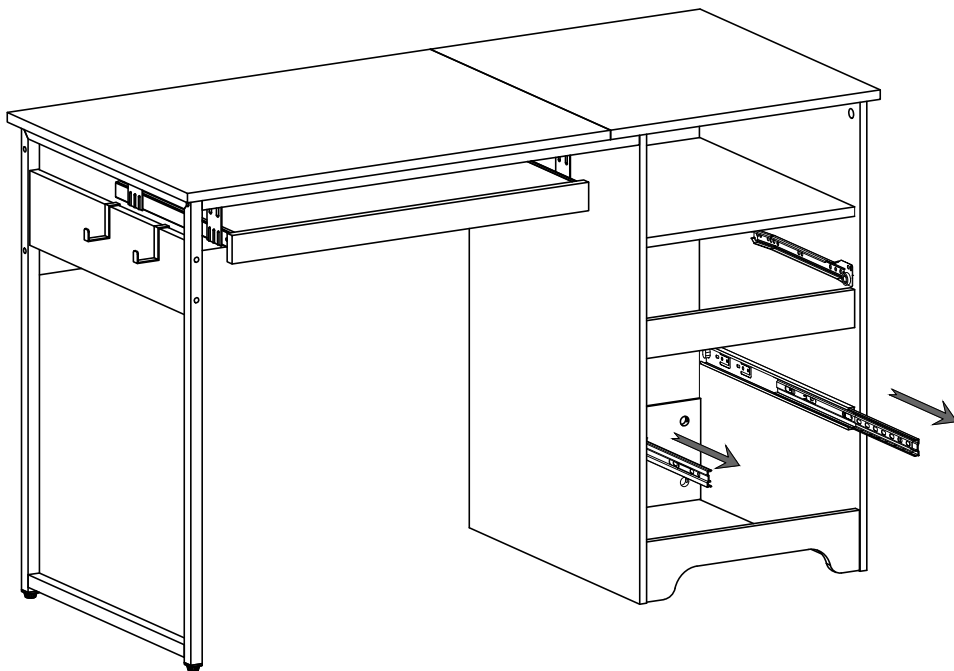

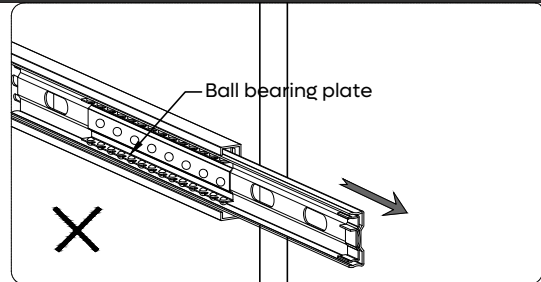
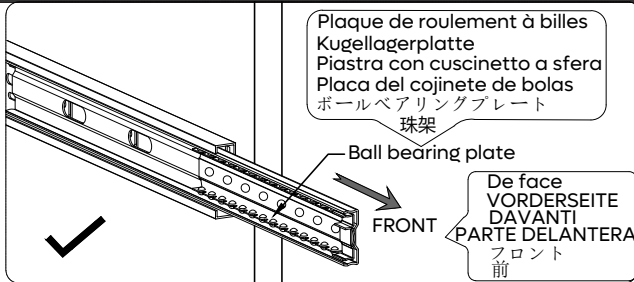

1

※Before inserting the Drawer, make sure to slide the ball bearing plates located on the Side Frames to the FRONT of the unit as illustrated.

※Avant d'insérer le tiroir, assurez-vous de faire glisser les plaques de roulement à billes situées sur les cadres latéraux à l'AVANT de l'unité, comme illustré.

※Bevor Sie die Schublade einsetzen, schieben Sie die Kugellagerplatten an den Seitenrahmen wie abgebildet nach VORN.

※Prima di inserire il cassetto, assicurarsi di far scorrere le piastre con cuscinetto a sfera situate sui telai laterali verso la parte anteriore dell'unità, come illustrato.

※Antes de insertar el cajón, asegúrese de hacer deslizar las placas de los cojinetes de bolas situadas en los marcos laterales hasta la parte FRONTAL de la unidad, como puede verse en la ilustración.

※引き出しを挿入する前に、図のように、サイドフレームにあるボールbearingプレートをユニットの前面にスライドさせてください。

※将两侧板上的导轨球架移至导轨最前端；

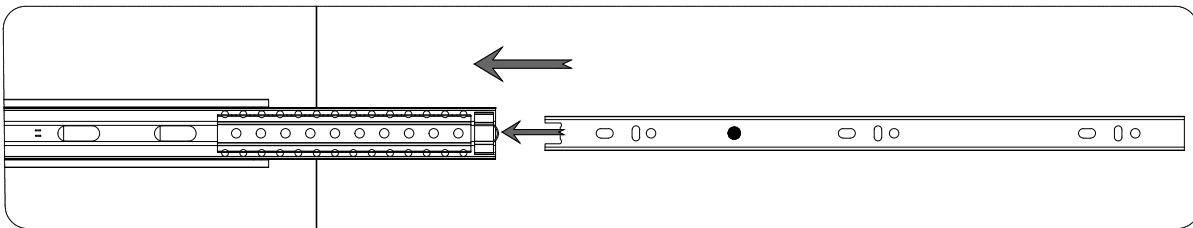

2

※Insert the rails on both sides of the drawer into the ball bearing plate and slowly push in horizontally.

※Insérez les rails des deux côtés du tiroir dans la plaque de roulement à billes et poussez doucement à l'horizontale.

※Führen Sie die Schienen auf beiden Seiten der Schublade in die Kugellagerplatte ein und schieben Sie sie langsam und waagrecht hinein.

※Inserire le guide su entrambi i lati del cassetto nella piastra con cuscinetto a sfera e spingere lentamente in orizzontale.

※Inserte los carriles de ambos lados del cajón en la placa de cojinete de bolas y empuje lentamente en dirección horizontal.

※引き出しの両側にあるレールをボールbearingプレートに差し込み、ゆっくりと水平に押し込みます。

※将抽屉两侧的导轨片，对准导轨最前端，水平缓慢将其推入；

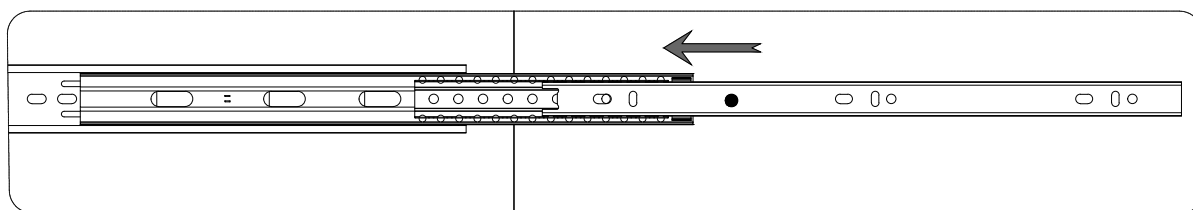

3

※Note: Push in slowly and horizontally.

※Remarque : poussez lentement et à l'horizontale.

※Hinweis: Schieben Sie sie langsam und waagrecht ein.

※Nota: Spingere lentamente e orizzontalmente.

※Nota Empuje lenta y horizontalmente.

※注意: ゆっくり水平に押し込みます。

※注意: 水平缓慢推入。

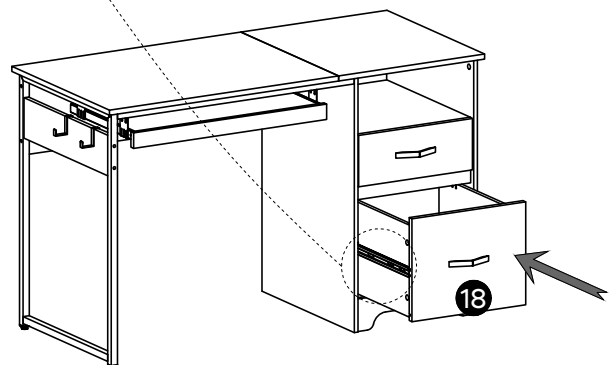

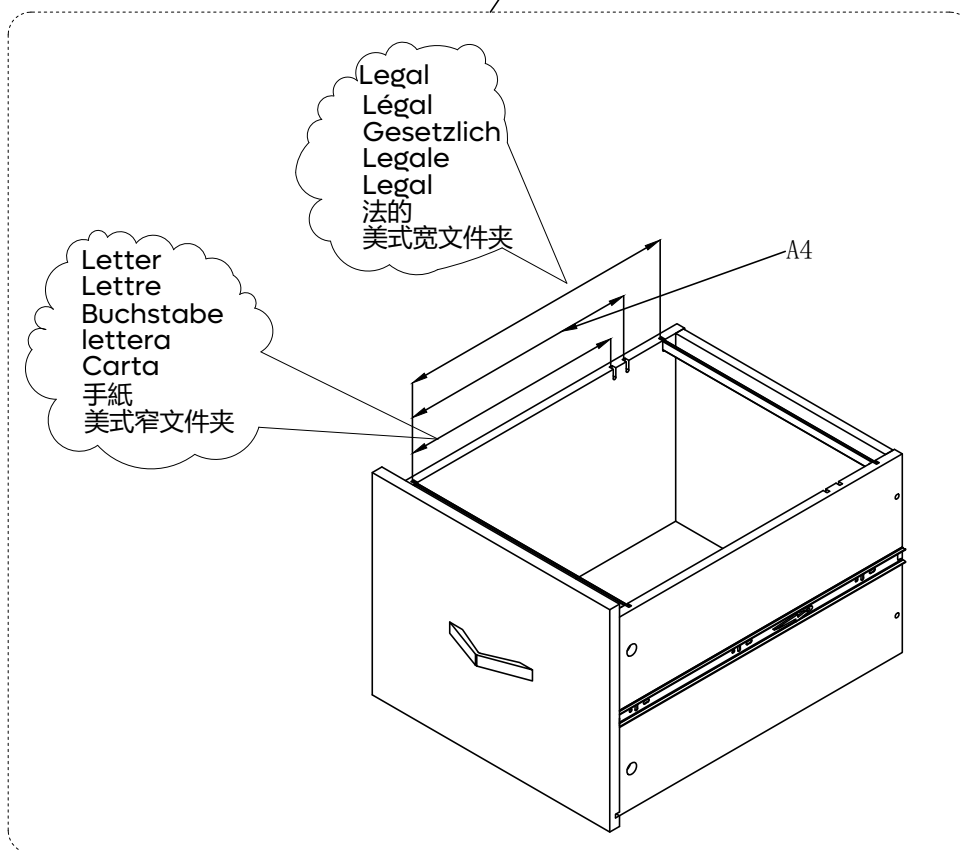
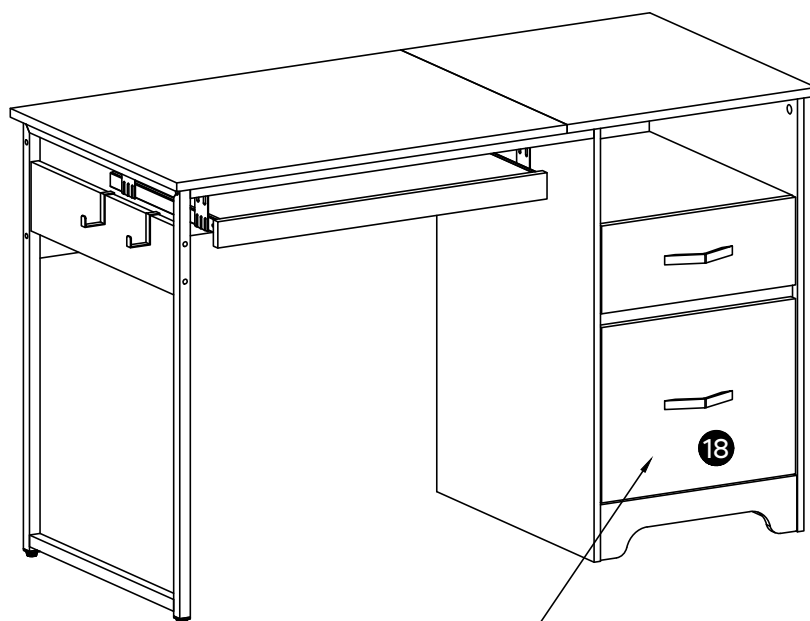

# Bestier

Love coming home.

Comfort Zone Co.,Limited

RM1903 19F BeiYou technology Building, Yuehai Street,  
No.42 Gaoxin South Ring Road,Nanshan,Shenzhen



<b>CUSTOMER SUPPORT 售后联系方式</b>		
<b>North American</b>	<b>Europe</b>	<b>Asia</b>
888-666-1086 Service.US@bestier.net	Service.UK@bestier.net Service.FR@bestier.net Service.ES@bestier.net	Service.DE@bestier.net Service.IT@bestier.net 04-8888-0283 Service.JP@bestier.net
<b>Global</b> Service@bestier.net      国内 电话: 0755-26917626      邮箱: sskj@bestier.net		