

SBC90 SANDBLAST CABINET

OPERATING INSTRUCTIONS AND PARTS MANUAL

MODEL: 40200004

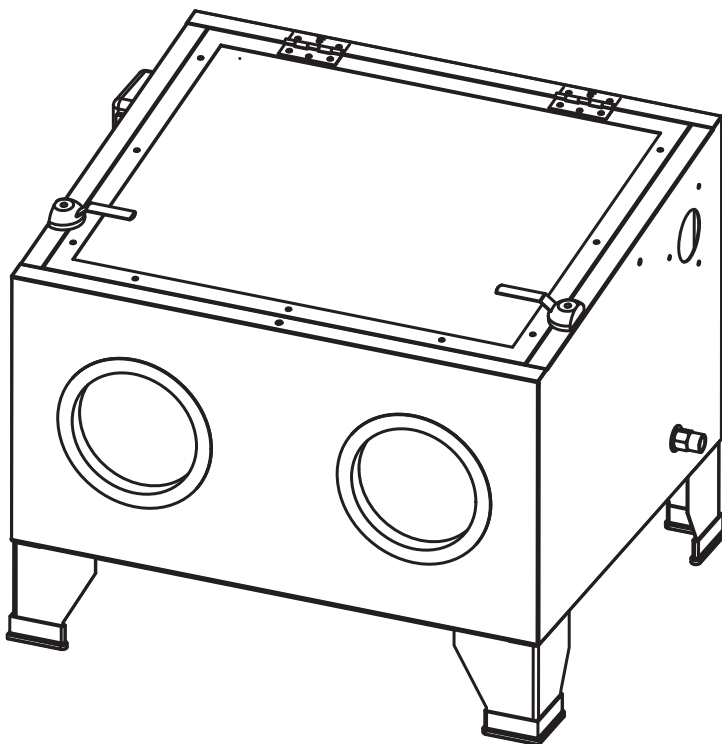

Please read and save these instructions.

Read through this owner's manual carefully before using product. Protect yourself and others by observing all safety information, warnings, and cautions. Failure to comply with instructions could result in personal injury and/or damage to product or property. Please retain instructions for future reference.

Operating Instructions and Parts Manual

Description

This Abrasive Blast Cabinet is designed for cleaning, polishing and finishing with dry abrasive ONLY.

Unpacking

After unpacking unit, inspect carefully for any damage that may have occurred during transit. Check for loose, missing, or damaged parts.

Specifications and Dimensions

Max. Work Pressure	Media Capacity	Dimensions		
		Length	Width	Height
125 PSI	2 Gallons	23 inches	18.9 inches	19.3 inches
125 PSI	7.5 Liters	58.5 cm	48 cm	49 cm

12V FLUORESCENT WORK LIGHT WITH 120VAC 60Hz/230VAC 50HZ input 12V 800mAoutput

Recommend Vacuum Air flow: NOT more than 200-350L/min (7CFM-12CFM)

General Safety Information

Any blast cabinet will produce a powerful flow of abrasive Particles. Please avoid personal injury and property damage. Study this manual thoroughly before assembling, operating or servicing this blast cabinet.

⚠️WARNING

1. During operation, do not expose the hands or skin directly in the line of the blast nozzle.
2. Ensure all components seal properly after assembly.
3. Do not exceed the maximum operating pressure of the blasting equipment
4. Disconnect the cabinet from the air supply before changing accessories or attempting to install, service, relocate or perform any maintenance.
5. Check hoses and air lines for weak or worn condition before each use. Make sure all the connections are secure before use.
6. Do not point the abrasive blaster gun at anyone or objects.

Operating Instructions and Parts Manual

⚠ DANGER

Chemicals, including lead includes in this product or its power cord. Wash hands after handling.



⚠ DANGER

The dust can be created when you sweep, blast, cut, sand, drill or grind materials such as wood, paint, metal, concrete, cement, or other masonry. This dust often contains chemicals known to cause cancer, birth defects, or other reproductive harm. Wear protective gear.



⚠ DANGER

Fire or Explosion Hazard! DO NOT USE a sand blaster around combustible or flammable liquids, dusts, gases, oily rags, or other materials that can explode or burn quickly. Some abrasives create sparks when they hit metal. Abrasives similar to aluminum oxide may generate static electric sparks which will cause fires or explosions in an unsafe environment.



⚠ DANGER

Static electric shocks can be painful. Please wear leather or rubber soled shoes or boots and stand on the ground to avoid static electricity. A grounded wire attached to the sand blast gun will safely remove the static electricity.



Assembly & Operation

Step 1 : Insert sand suction adapter (23) into the bottom of the funnel with a flat washer and locked by M16 Nut (37).

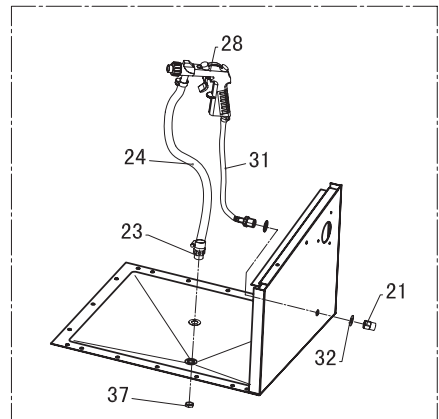

Assembly & Operation

Step 2:

1. Place cabinet on a workbench where you will be working.
2. Connect air supply (21) (max. 125 psi) to the fitting on the side of the cabinet.
3. Check if there are any leaks for air. If any, repairing or adding Teflon tape is needed.
4. Plug the 12V power supply into a 110V/230V wall outlet. Ensure the switch is in the OFF position, plug the other end of 12V power supply cord into the light switch on the cabinet.
5. Check if the light works.
6. Add a plastic window protector to the inside surface of the glass door.
7. Eye protection need to be done before load no more than 7.4 liters in to the cabinet. Excessiveness will cause the ineffective performance.
8. Close and latch door(18).
9. Protect your hands in gloves(15), aim blast gun (28)at surface to be cleaned and pull trigger. If there is no flow, please clear the tube by covering the gun nozzle.

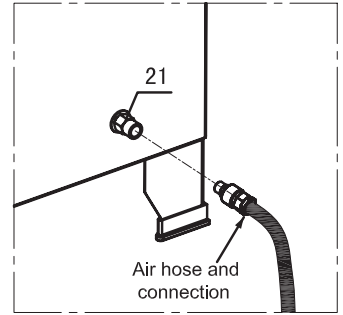

Maintenance

- Secure the glove (15) with glove clamp (16) onto the front panel as illustrated.

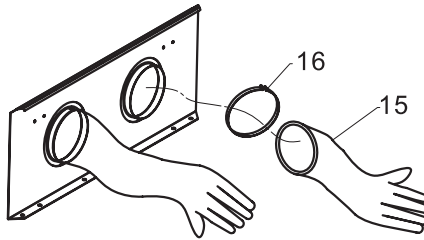

- Push the fluorescent lamp (2) forward into lamp clip (3). Then put the enclosed on the cord to secure the hole through left panel.

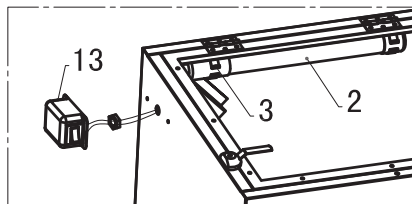

Maintenance

NOTE: Disconnect power and air before the maintenance.

Cleaning: please clean the plastic door or parts with a soft cloth. **DO NOT** use solvents to clean.

Avoiding Block: the moist media will cause the block of nozzle. Try dislodging the media with a drill bit.

Blast Gun Connection: Please assemble them as picture shown, when a blast gun (28) need to be replaced.

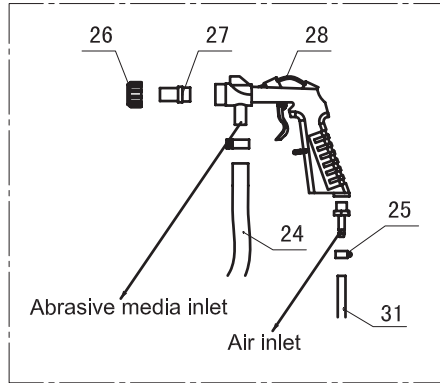

Troubleshooting Chart

Symptom (s)	Possible Causes(s)	Corrective Action(s)
Excessive dust in the cabinet	<ol style="list-style-type: none"> 1.Exhaust vent or air flow block. 2.Air fittings and connections losing. 3.Overload abrasive media inside of the cabinet. 	<ol style="list-style-type: none"> 1.Clean the vent and keep it away from any wall. 2.Tighten fittings and make sure all the connections are secure. 3.Remove the excessive media.
Uneven blasting actions	<ol style="list-style-type: none"> 1.Moisture present inside of the cabine. 	<ol style="list-style-type: none"> 1.See Caution in General Safety Information.
Improper speed or Inefficient blast	<ol style="list-style-type: none"> 1.Abrasive media worn. 2.Pressure too low. 	<ol style="list-style-type: none"> 1.Replace media 2.Increase inlet pressure and make sure control valve is fully opened.
Gun will not shut off Trigger stuck	Damaged o-rings in air valve	Remove and replace o-rings.

Parts

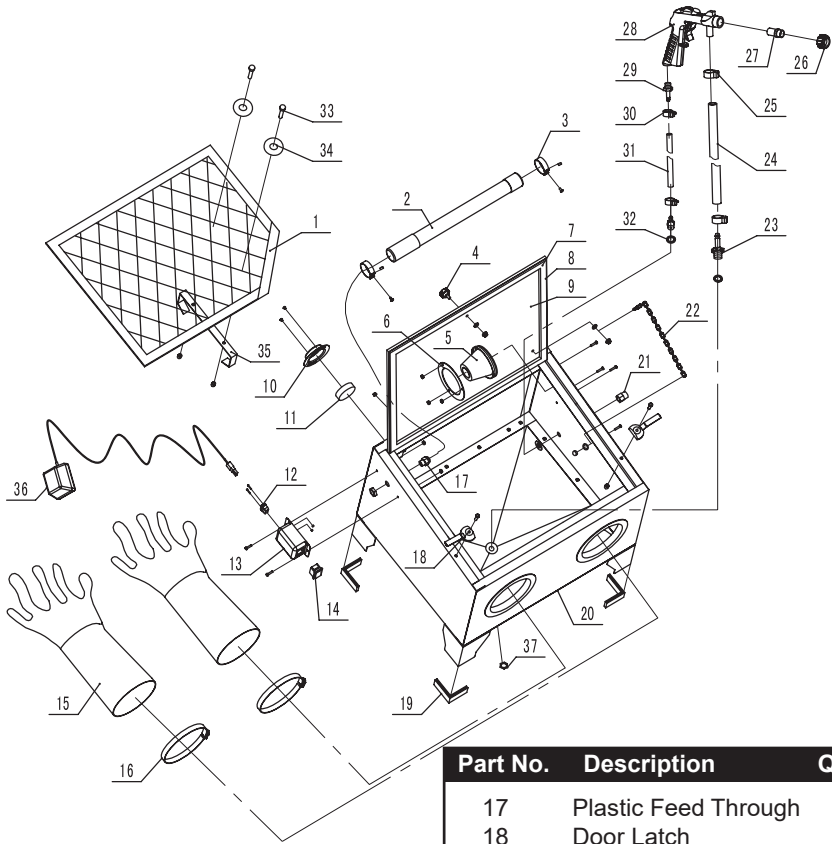

Part No.	Description	Qty.
1	Steel Screen	1
2	Fluorescent Lamp	1
3	Lamp Clip	2
4	Knob	2
5	Filter	1
6	Retaining Ring	1
7	Glass	1
8	Foam Pad	1
9	PE Film	1
10	Filter Housing	1
11	Cabinet Filter	1
12	Switch Outlet	1
13	Lamp Switch Box	1
14	Lamp Switch	1
15	Gloves	1 Pair
16	Large Hose Clamp	2

Part No.	Description	Qty.
17	Plastic Feed Through	1
18	Door Latch	2
19	Foot Cover	4
20	Cabinet	1
21	Air Adapter Nut	1
22	Chain	1
23	Sand Suction Adapter	1
24	Abrasius Intake Hose	1
25	Large Hose Clamp	2
26	Nozzle Adapter Nut	1
27	Nozzle Sets	4
28	Blasting Gun	1
29	Air Hose Adapter	1
30	Small Hose Clamp	2
31	Air Inlet Suction	1
32	Flat Washer	6
33	Screw M6*15	2
34	Flat Washer	2
35	Rack Leg	1
36	AC Adaptor	1
37	M16 Nut	1