

PLEXALIFE™

SOLAR LIGHTS FOR SHEDS

INSTRUCTION MANUAL

Item #PLC-SOLARL-BX1/1

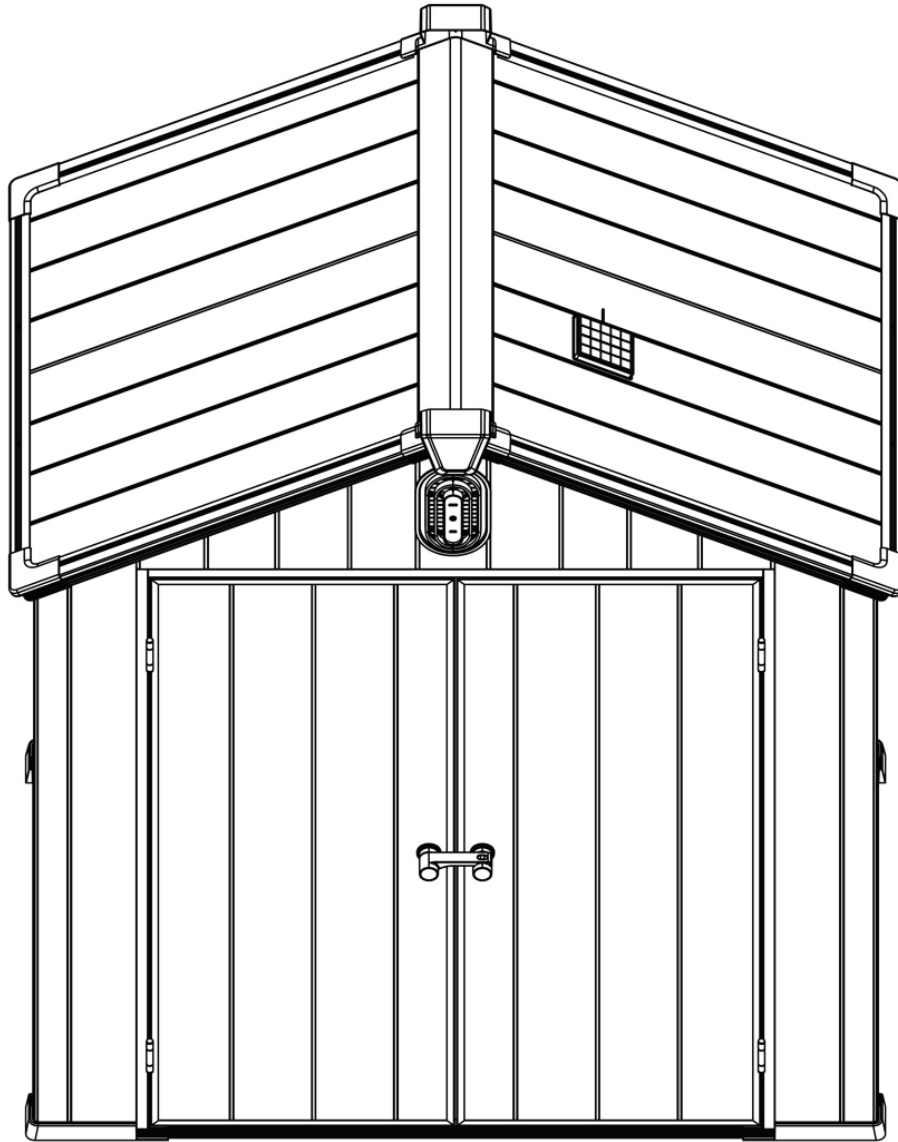

SCAN HERE to Activate your extended warranty

WARRANTY

PLEXALIFE™

Exclusively Distributed by
Pharo Deals NY Inc.

support@pharodeals.com
www.pharodeals.com

Accessory & Parts

Item no.	Reference Image	Parameter	Qty.
IM2.1		LED strip with conduit 15.6 * 14.6 with adhesive magnetic strip PC tube length 600, wire length 500, waterproof male connector, self-light	X1
IM2.2		Solar-powered rechargeable battery case Black 5.5*2.1/2C*24AWG DC straight male plug wire, 1.2m in length	X1
IM2.3		TJ2 Power Bank_DC 21700 3.6V 4600mAh (PH)7015 Single Channel Black	X1
IM2.4		TJ2 Charging Dock DFSS-0702-CONB-V02 Black	X1
IM2.5		Power light string connecting cable Waterproof female connector cable, cable length 1500mm/XH-2Y	X1
IM2.6		magnet φ20*5.7mm Center counterbore 4.0mm N40	X2
IM2.7		Cable organizer	X5
FT.13	M4x16 		X3
IM2.8			X1
FT.6	ST4x14 		X5

SS-0705 product function and design parameters description

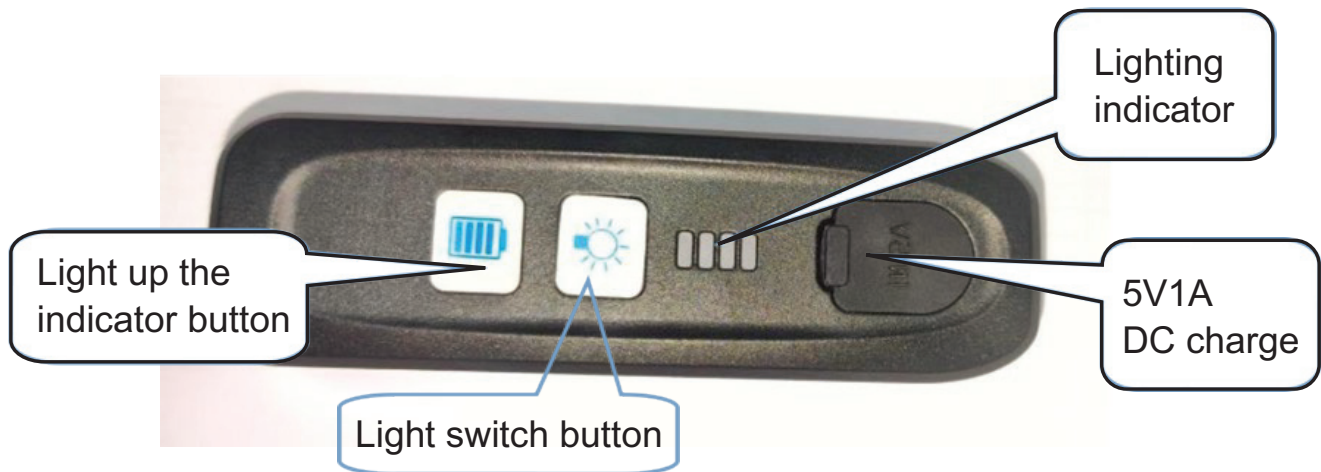

I. Product images



II. Main configuration and parameters

- This product is a power bank light bar controller; constant current control circuit,
- Static current: less than 200UA
- 21700 ternary lithium battery 3.6V battery capacity 4600MAH
- Average discharge time: 5 hours
- Total lamp lumens: 260LM
- Solar panel power: 2W (5V/400 MAH) charging time 14 hours (subject to actual weather conditions)
- Maximum discharge power: 3 W (850 MAH/3.6V)
- Charging method: DC charging
- Charging time: 5V/1000MAH more than 5 hours (subject to actual conditions)

III. HOW TO USE

- Control the lighting mode  the light 1, short press the key to open  the light 2, again short press the key to turn off the lighting mode
- In order to prevent the light from causing harm to human eyes and vision, do not look directly at the light source when the product is bright.

IV. Disposal

- The product should not be discarded in the household waste treatment point, but should be properly recycled to promote the sustainable recycling of raw material resources, so as to reduce its impact on the environment or human health;
- For the disposal of used equipment, please contact the recycling center or the product distributor.

III. Assembly

1



IM2.8
1pcs



FT.6
4pcs



IM2.2
1pcs

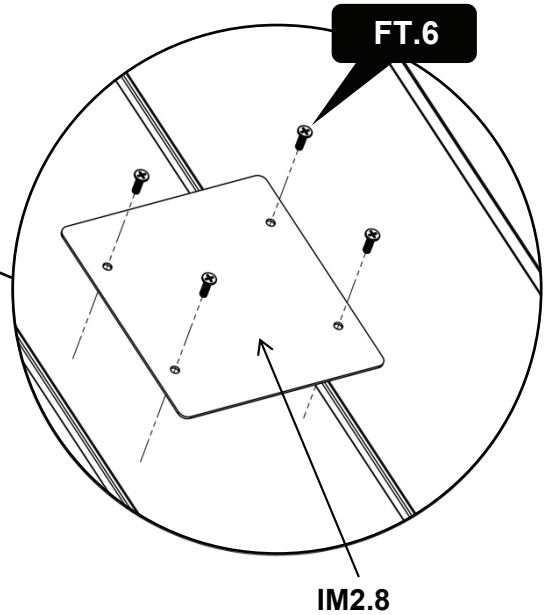
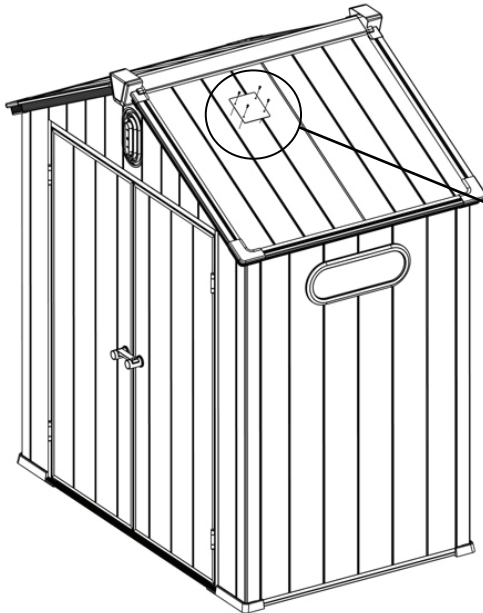

Notes: Fix the IM2.8 to the roof with screws FT.6 .

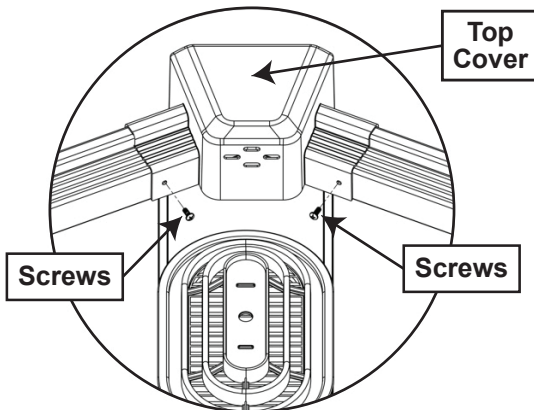

- ① Remove the screws from the top cover and then the top cover

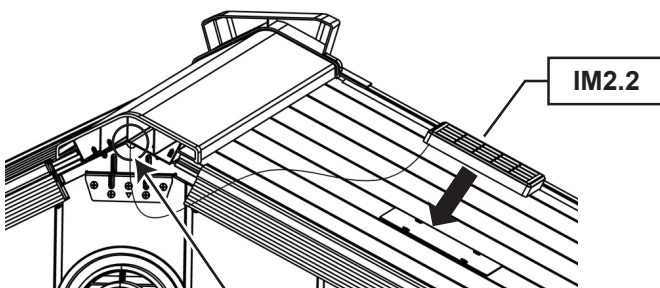

- ② Hold the solar panels (IM2.2) by magnets on its back onto the IM2.8 and send the wires into the sheds from the opening of the top cover as shown in the picture.

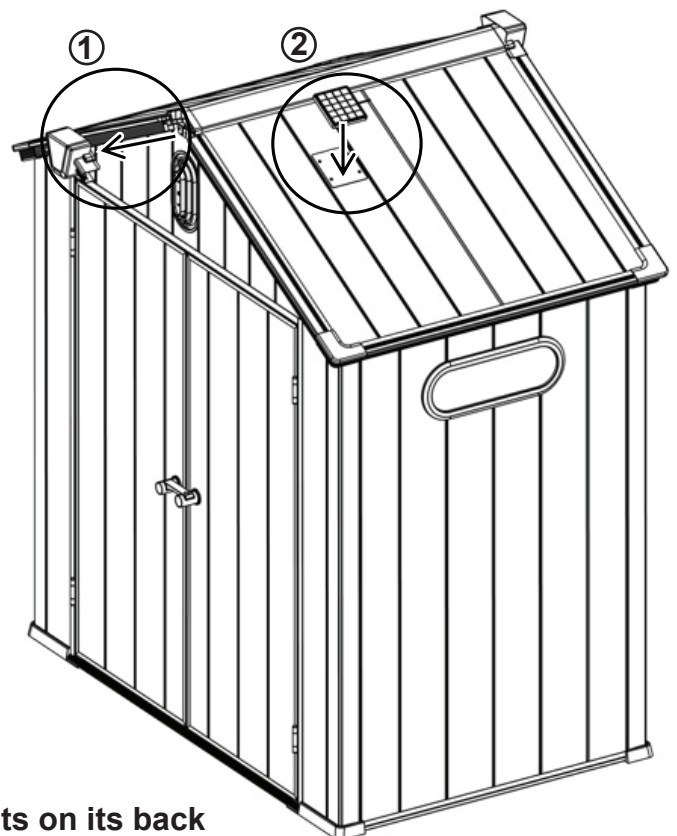

2



IM2.4
1pcs



IM2.6
2pcs



FT.13
2pcs



IM2.1
1pcs

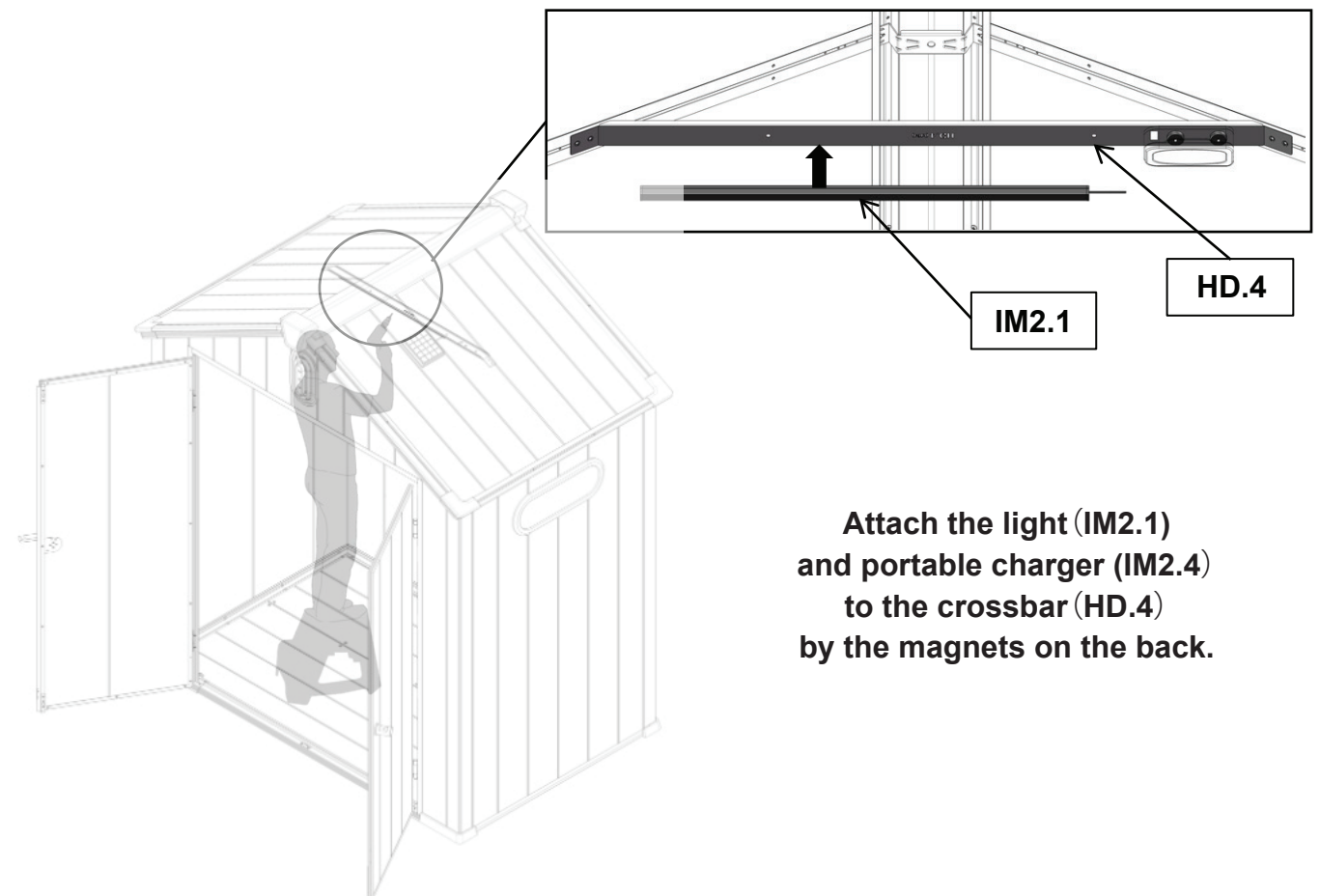
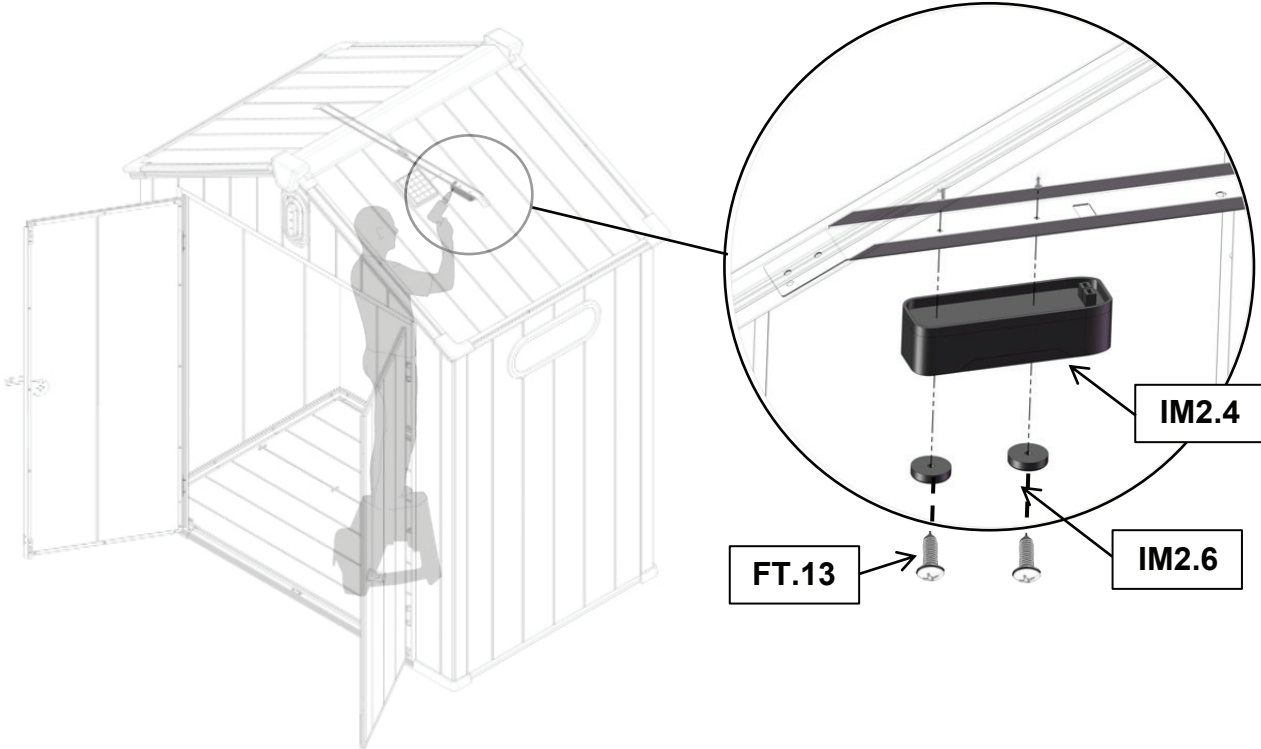

Attach the light (IM2.1)
and portable charger (IM2.4)
to the crossbar (HD.4)
by the magnets on the back.

2



IM2.5
1pcs



IM2.7
2pcs

Use wire organizers (IM2.7) to hide all the wires (IM2.5) under the FR.7.

