

3 Installation

3.1 Installation Instructions

1. The installation must conform with local codes or, in the absence of local codes, with the National Fuel Gas Code, ANSI Z223.1/NFPA 54, and/or CSA B149.1, Natural Gas and Propane Installation Code.
2. All water heaters require proper and careful installation to ensure safe and efficient operation. This manual must be strictly observed.
3. The manifold pressure is preset at the factory. It is computer-controlled and does not require adjustment.
4. Maintain proper maintenance space when installing equipment so that it can be easily connected or removed.
5. The electrical connection requires disconnecting the water heater for maintenance and safety to turn off the power to the water heater.
6. Do not install the water heater where the exhaust vents point to any openings in the building or where noise may disturb the neighbors. Ensure that the vent terminal meets the required distance from any door or opening by local regulations to prevent exhaust gases from entering the building.
7. Carefully select the installation location of the water heater. Lint and fine powder contaminants such as flour can block the air intake and reduce fan operation. This, in turn, can lead to burning anomalies and shorten the life of the water heater. Regularly ensure that the area around the water heater and the air inlet are free of dust, debris, and other contaminants.
8. This water heater is for indoor installation only.
9. The water heater requires a 3 in. / 5 in. concentric vent pipe. See the subsequent sections for more details.
10. Only install the water heater in a heated area where the temperature cannot be below freezing. The warranty does not cover damage caused by freezing.
11. The water heater must be securely mounted to a wall or other suitable structure.
12. The water heater cannot be installed on the floor.

Installation and repair must be performed by a qualified installer (for example, a licensed plumber or gas fitter) or the warranty will be void.

The installer (authorized professional) is responsible for properly installing the water heater and complying with all national, state/provincial, and local regulations.

The manufacturer does not recommend installing the water heater in a pit or location where gas and water may accumulate.

Do not point the vent to any operating window, door, or opening to the building.

Do not install near any air debris source (such as a dryer) that could cause debris to get trapped in the combustion chamber unless the system is directly vented.

Do not install the unit in water, debris, or flammable vapors that may enter the flue terminal or intake line.

Due to safety issues, the manufacturer does not recommend installing the water heater in the attic.

Make sure the equipment has adequate combustion air and proper ventilation. Failure to do so may result in carbon monoxide poisoning or death.

Keep the area around the water heater clean. When dust collects on the flame, the sensor will turn off and display the error code.

Place the equipment for easy repair and maintenance.

If a leak occurs, it is recommended to install a drain pan or other waterproof protection under the water heater.

Failure to follow these warnings can result in serious personal injury, death, and/or property damage.

Installation and repair must be performed by a qualified installer (for example, a licensed plumber or gas fitter) or the warranty will be void.

The installer (authorized professional) is responsible for properly installing the water heater and complying with all national, state/provincial, and local regulations.

The manufacturer does not recommend installing the water heater in a pit or location where gas and water may accumulate.

Do not point the vent to any operating window, door, or opening to the building.

Do not install near any air debris source (such as a dryer) that could cause debris to get trapped in the combustion chamber unless the system is directly vented.

Do not install the unit in water, debris, or flammable vapors that may enter the flue terminal or intake line.

Due to safety issues, the manufacturer does not recommend installing the water heater in the attic.

Make sure the equipment has adequate combustion air and proper ventilation. Failure to do so may result in carbon monoxide poisoning or death.

Keep the area around the water heater clean. When dust collects on the flame, the sensor will turn off and display the error code.

Place the equipment for easy repair and maintenance.

If a leak occurs, it is recommended to install a drain pan or other waterproof protection under the water heater.

Failure to follow these warnings can result in serious personal injury, death, and/or property damage.

The warranty does not cover damage caused by water quality.

For all other types of applications, the water hardness level for single-family applications should not exceed 7 grains per gallon (120 ppm) or 4 grains (70 ppm) per gallon. The hardness of the water can cause scaling and can affect/damage the water heater. Hard scale must be avoided or controlled by proper water treatment.

This water heater can only use drinking water. Do not introduce pool or hot spring water or any chemically treated water into the water heater.

The pH of the water must be between 6.5 and 8.5.

Well water must be disposed of.

When the water heater is installed in a beauty salon, dry cleaner, or in an area where such chemicals exist, the manufacturer recommends direct venting. Certain chemicals used in beauty salons or dry cleaners may affect the flame sensor. In this circumstance, the water heater may not work properly.

Although the water heater is designed to operate with minimal sound, the manufacturer does not recommend installing the unit on a wall close to a bedroom or in a room intended for quiet study or meditation.

The water heater must be located in an area where leakage of the unit or connections will not result in damage to the area adjacent to the appliance or to lower floors of the structure. When such locations cannot be found, installation of an adequately drained drain pan under the water heater is highly recommended. When installing the drain pan, ensure that the installation does not restrict combustion air flow.

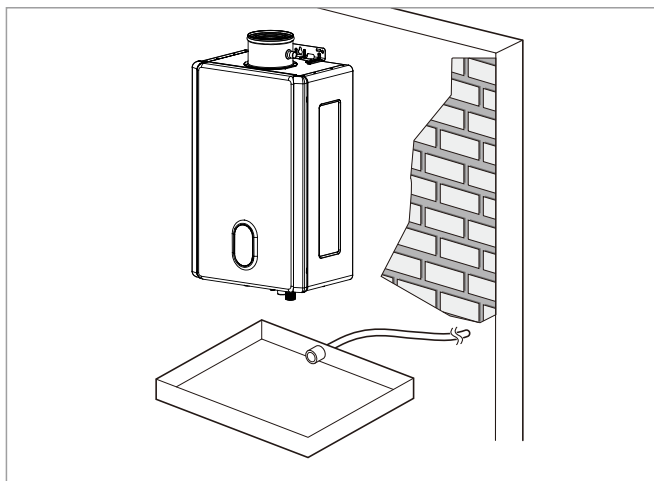

3.2 Installation Checklist

- Unbox and check whether the water heater, installation manual and owner's guide, parts and accessories bag, are coming in the box.
- Check to ensure there are no corrosive chemicals in the air intake.
- Water supply should be free of chemicals, and water hardness that higher than allowed level may damage the water heater.
- Ensure there is enough space required for installation.
- Ensure there is enough distance required between the exhaust vent and air inlet of houses.
- Ensure you are using the right exhaust vent products, and follow the installation manual from the suppliers.
- For indoor water heater models, ensure the number of elbows used does not exceed the maximum quantity allowed, and the exhaust vent pipe's total length (including the elbows, each is equivalent to 6 feet) does not exceed the maximum length allowed for the water heater.
- Slope horizontal exhaust run towards the water heater 1/4 in. per foot (21 mm per meter). DO NOT slope intake air pipe towards water heater.
- Turn off hot water switch, turn on cold water switch and the drain screw, flush the debris and air out of the water pipes. Debris inside the water may damage the water heater. Please use buckets or extra water pipes if needed.
- Ensure no water leakages.
- Turn off cold and hot water switches before cleaning up water inlet filter. Put a bucket under the water heater's filter to catch any water out of the water heater. Screw out the water inlet filter, wash off debris and dusts, and then hand screw the filter back in. When it's done, turn on the cold and hot water switches.
- Ensure the pressure relieve valve's relieving capacity exceeds that of the water heater BTU input rating. Please refer to the specifications on the side of machine for BTU input ratings.
- Install a manual gas shut-off valve between the water heater and your gas supply line.
- Check to confirm there is no gas leakage in piping and fittings.
- Confirm the gas inlet pressure in the min-max range as required.
- Confirm you are using the gas type as required by the water heater.
- Confirm the power supply is 120 V/60 Hz, and properly grounded.
- Confirm the thermostat works normally.

- Connect a gas manometer to the pressure port to verify the system is working normally. Turn on appliances that use high flow rate hot water and set the water heater to its maximum operation capacity, the inlet gas pressure must be higher than the minimum pressure on the specification label.
- Do not induct poisonous chemicals into drinking water, like the chemicals used to process broiler water.
- Drain the water out of the water heater if you are not using the water heater for a significant time period.

3.3 Prepare for installation

The following tools are recommended for installing the water heater.

■ Parts included

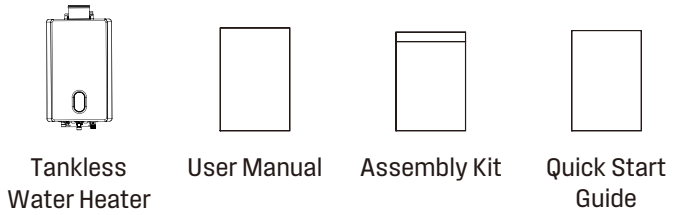

■ Tools and Materials needed (Not included)



■ Materials that may be needed (Not included)

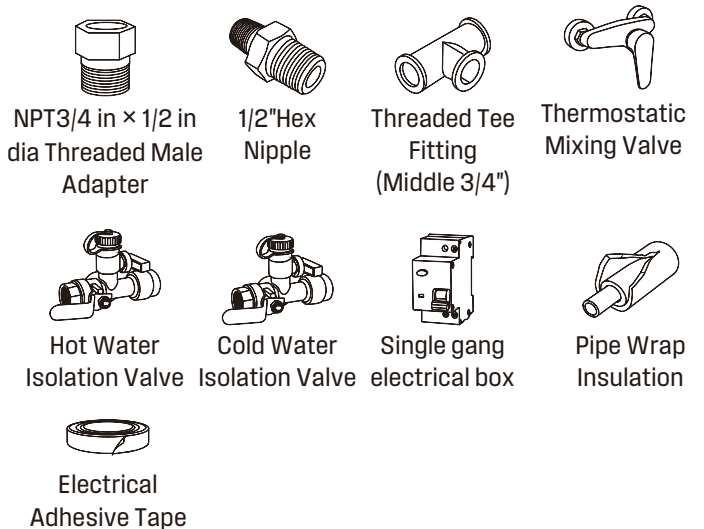

3.4 Determine Installation Location



WARNING

- DO NOT Install in areas where air for combustion can be contaminated with chemicals.
- Before installation, consider where air has the ability to travel within the building to the water heater.
- Make sure the equipment has adequate combustion air and proper ventilation. Failure to do so may result in carbon monoxide poisoning or death.
- Chemicals that are corrosive in nature should not be stored or used near the water heater.



WARNING

- Install the water heater as far away as possible from exhaust vent hoods.
- Install as far away as possible from air inlet vents. Corrosive fumes may be released through these vents when air is not being brought in through them.
- Chemicals that are corrosive in nature should not be stored or used near the water heater or vent termination.

When selecting an installation location, you must ensure that all water heater and venting clearances will be met and that the vent length will be within required limits. Consider the installation environment, water quality, and the need for freeze protection. Requirements for the gas line, water lines, and electrical connection can be found in their respective installation sections in this manual.

Water quality

The water must be potable, free of corrosive chemicals, sand, dirt, or other contaminants. It is up to the installer to ensure the water does not contain corrosive chemicals or elements that can affect or damage the heat exchanger.

Consideration of care for your water heater should include evaluation of water quality. Water that contains chemicals exceeding the levels below can affect and damage the heat exchanger. Replacement of the heat exchanger due to water quality damage is not covered by the warranty.

Water Quality Guidelines

Contaminant	Maximum Level
Total Hardness	Up to 200 mg/L
Aluminum*	Up to 0.2 mg/L
Chlorides*	Up to 250 mg/L
Copper*	Up to 1.0 mg/L
Dissolved Carbon Dioxide (CO ₂)	Up to 15.0 mg/L
Iron*	Up to 0.3 mg/L
Manganese*	Up to 0.05 mg/L
pH*	6.5 to 8.5
TDS (Total Dissolved Solids)*	Up to 500 mg/L
Zinc*	Up to 5 mg/L

*Source: 40 CFR Part 143 National Secondary Drinking Water Regulation

Environment

The water heater, venting, and vent termination(s) should not be installed in any areas where the air may contain these corrosive compounds. If it is necessary for a water heater to be located in areas which may contain corrosive compounds, the following instructions are strongly recommended.

Air surrounding the water heater, venting, and vent termination(s) is used for combustion and must be free of any compounds that cause corrosion of internal components. These include corrosive compounds that are found in aerosol sprays, detergents, bleaches, cleaning solvents, oil-based paints/varnishes, and refrigerants. The air in beauty shops, dry cleaning stores, photo processing labs, and storage areas for pool supplies often contains these compounds.

Therefore, it is recommended that outdoor models be used for these locations where possible.

The water heater, venting, and vent termination(s) should not be installed in any areas where the air may contain these corrosive compounds. If it is necessary for a water heater to be located in areas which may contain corrosive compounds, the following instructions are strongly recommended.

IMPORTANT CONSIDERATIONS FOR:

Indoor Water Heaters

- DO NOT install in areas where air for combustion might be contaminated with chemicals.
- Where possible, install the water heater in a sealed closet so that it is protected from the potential of contaminated indoor air.
- Before installation, consider where air has the ability to travel within the building to the water heater.
- Chemicals that are corrosive in nature should not be stored or used near the water heater.

3.5 Installation Space

■ Clearances



WARNING

Keep all the space around the water heater. Failure to do so may result in fire and may result in death, injury and or property loss.

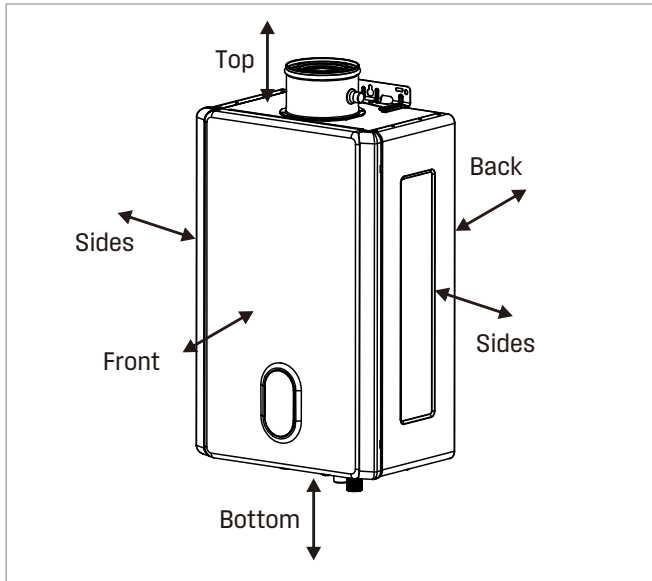

Top	Bottom	Front	Back	Side
12 in. (305mm)	12 in. (305mm)	24 in. (610mm)	0 in. (0mm)	6 in. (150mm)

Table 1

Provide clearances as outlined in Table 1

As for vent connector and hot water pipe from combustible construction, please consult with a qualified technician.

If the heater was installed in a narrow space or corner, please ensure that there is sufficient space for service and maintenance access. For regular maintenance, there should not be any problem to approach gas and water line.

3.6 Mount to Wall

1. After considering all required clearances and ensuring proper air supply and ventilation locations, determine the optimal mounting position for the wall bracket. The wall must be constructed of concrete, wood, or plywood, must contain structural studs, and must be strong enough to support the weight of the water heater. Refer to Section 3.3 Specifications for the unit weight.
2. Secure the upper and lower mounting brackets firmly to the wall, ensuring that all screws are fully driven in and flush with the wall surface.

- Any mounting hole on the upper and lower brackets may be used.
- Use a level (either horizontal or vertical) to ensure the water heater is mounted perfectly level. The unit must be level for proper operation.
- Ensure that the mounting method and wall structure are capable of supporting the full weight of the water heater.

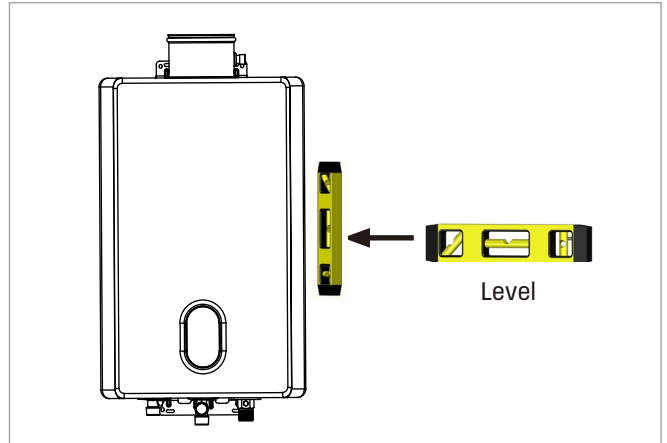

WARNING: IMPORTANT

The water heater must be installed in an upright position. DO NOT install the water heater upside down or on its side.

3.7 Venting the Water Heater



DANGER

The vent system will operate with a positive pressure in the pipe. Exhaust gases must be piped directly outdoors using the vent materials and rules outlined in these instructions. Do not connect vent connectors serving appliances vented by natural draft into any portion of mechanical draft systems operating under positive pressure. Follow the venting instructions carefully. Failure to do so will result in substantial property damage, severe personal injury, or death.



WARNING

Improper venting of the water heater can result in excessive levels of carbon monoxide, which can lead to severe personal injury or death. This water heater must be vented in accordance with the "Venting of Equipment" section of the latest edition of the ANSI Z223.1/NFPA 54 Natural Fuel Gas Code in the USA, as well as all applicable local building codes and regulations. Follow all instructions and guidelines when venting the water heater. Venting should be performed only by a qualified service agency.

- Venting system must be sealed gas tight to prevent flue gas spillage and carbon monoxide emissions, which will result in severe personal injury or death.
- The building owner is responsible for keeping the exhaust and intake terminations free of snow, ice, or other potential blockages, as well as scheduling routing maintenance. Blocked or obstructed vent piping terminations could result in property damage, severe personal injury, or death.

The water heater is designed for a concentric venting system, which uses one pipe with two ducts for combustion air and exhaust air, respectively.

The water heater must be properly vented to ensure a constant supply of clean intake air and to ensure that exhaust air is properly removed from living areas. The vent system must vent directly to the outside of the building and use outside air for combustion.

When venting the water heater, follow these guidelines

- Do not install the water heater in areas with contaminated air (containing a high level of dust, sawdust, sand, flour, aerosols, or any other such airborne contaminants), as contaminants can cause operational problems. The warranty does not cover damage caused by contaminants in the installation area.
- Do not use PVC, CPVC, ABS, or any galvanized material to vent the water heater.
- Do not combine any vent components or parts from different manufacturers.
- Do not lessen the vent diameter.
- Do not connect the venting system with an existing vent or chimney.
- Do not vent in common with the vent pipe of any other water heater or appliance.
- For best results, keep the venting system as short and straight as possible.
- Locate the water heater as close as possible to the vent termination.
- For horizontal runs, slope the horizontal section upward toward the vent termination at a rate of 1/4 in per foot (2 % slope) when using a condensate collector. Slope the horizontal section downward toward the vent termination when not using a condensate collector. Refer to the manufacturer's instructions for using a condensate collector.
- Do not vent in common with the vent pipe of any other water heater or appliance.
- Create an airtight seal at the joint in the vent pipe that leads from the water heater collar to the vent termination by fully inserting the vent pipe into the water heater collar. The vent pipe must be inserted 1.3 in (34 mm) into the water heater collar. Once fully inserted, mark the vent pipe with a permanent marker directly above the water heater collar to observe any displacement during the installation process. If displaced, then readjust the vent pipe to ensure full insertion into the water heater collar.

3.8 Exhaust Pipe Specifications

- The maximum length of exhaust vent piping must not exceed 43 ft (13.3 m) for 3 in.x5 in. concentric pipe (76.2 mm/127mm) venting, which depends on the elevation where the water heater is installed, Do not use more than 5 elbows. See the table below.
- When the horizontal vent run exceeds 5 ft (1.5 m), support the vent run at 3 ft (0.9 m) intervals with overhead hangers.

Vent Type	Diameter	Number of 90° Elbows	Maximum Vent Length
Concentric	3 in./ 5 in. (80 mm / 125 mm)	0	43 ft (13.3 m)
		1	37 ft (11.5 m)
		2	31 ft (9.7 m)
		3	25 ft (7.9 m)
		4	19 ft (6.1 m)
		5	25 ft (4.3 m)

For each elbow added, deduct 6 ft (1.8 m) from max. vent length.

The Maximum Vertical and Horizontal (Total) Vent Length does not include any elbows.

- Each 90° elbow is equivalent to 6 feet of vent length.
- Two 45° elbows are equivalent to one 90° elbow.
- The value in the table include the terminating vent length.
- The condensate collector must be used if the venting system height is more than 5 ft (1.52 m) above the water heater.

3.9 Venting Instructions



WARNING

- Improper installation of ventilation on this equipment can result in excessive carbon levels and carbon monoxide can cause severe personal injury or death.
- Improper installation can result in nausea or suffocation, serious injury or death from carbon monoxide and smoke poisoning. Improper installation will void the product warranty.

Indoor models must be vented according to the current version of the National Gas Code "Equipment Exhaust" section: US ANSI Z 223.1/NFPA 54 and/or B 149.1 NATURAL GAS section 8 Canadian PROPANE and PROPANE INSTALLATION specifications, And applicable local building codes.

General rules for venting water heaters:

- Place the water heater as close as possible to the vent termination.
- Exhaust pipe must be easily removed from the top of the

water heater for proper service and inspection.

- Avoid using oversized exhaust pipes or using extremely long pipes unless it is part of an approved general exhaust system.
- For roof ventilation, a rain cap or other form of terminal must be installed to prevent rain from entering indoor.
- A water heater shall not be connected to a chimney flue serving a separate appliance, designed to burn solid fuel.
- Provisions for adequate combustion and ventilation air in accordance with one of the following:
 - A) The National Fuel Gas Code, ANSI Z223.1/NFPA 54.
 - B) CSA B149.1, Natural Gas and Propane Installation Code.
 - C) Applicable provisions of the local building code.
- Minimum clearances from combustible or noncombustible construction,6 inches sides,0 inches back, and 12 inches top. Minimum clearance from Type B flue or vent connector to combustible construction 1 inches. Type B

General rules for the termination of vents:

- The water heater should not be connected to the chimney flue of a separate unit used to burn solid fuel.
- Avoid placing the water heater exhaust terminal near any indoor air intake. These fans can take the exhaust flue products out of the water heater and return them to the building. This can be harmful to your health.
- Locate the exhaust terminal so that it will not be blocked by any debris at all times. Most specifications require the terminal to be at least 12 inches (305 mm) above grade and the expected snow level, but the installer can determine if it should be higher based on job site conditions and applicable specifications.

3.10 Direct Vent Terminal Clearances (Indoor Units)

For indoor models, you must install a vent termination to bring in combustion air and expel exhaust to the outside.

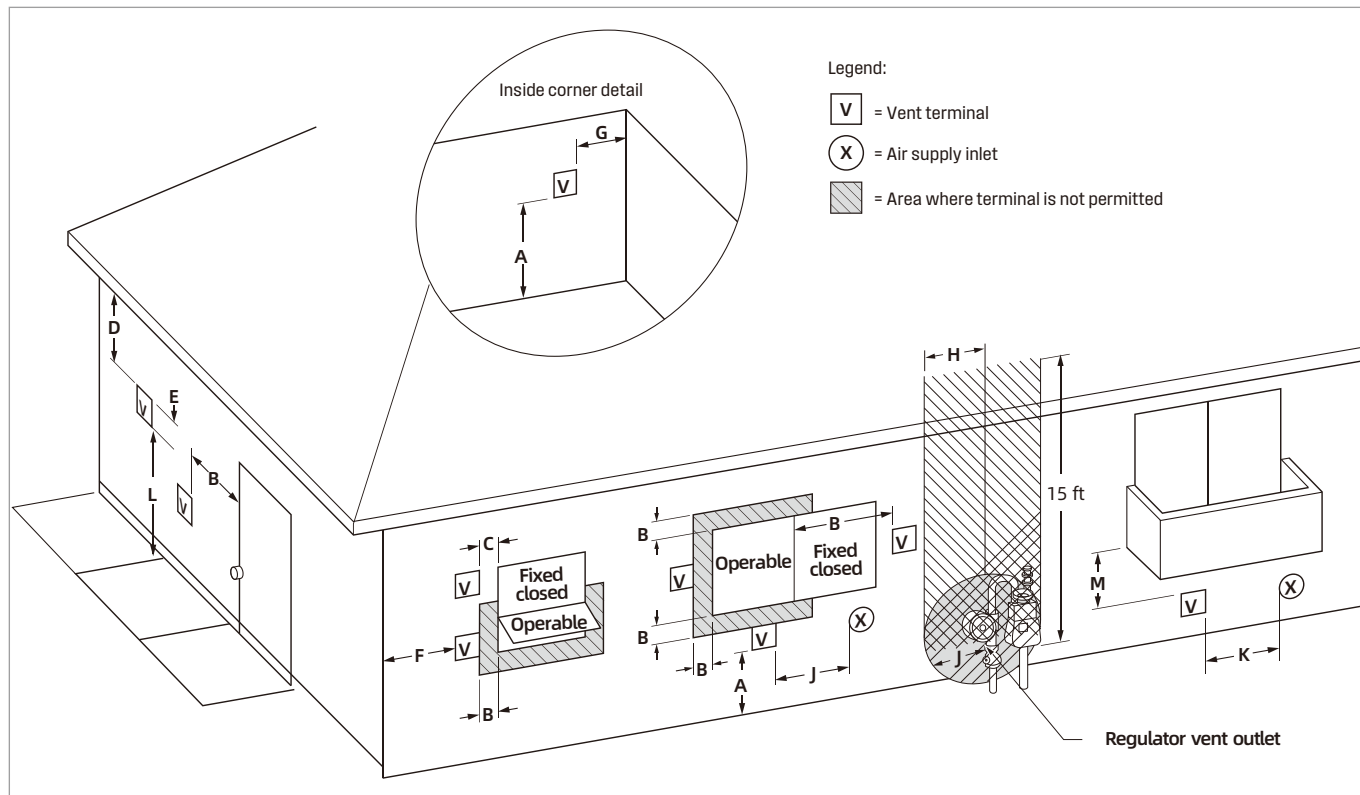

	Description	Canadian installations	US installations ²
A =	Clearance above grade, veranda, porch, deck, or balcony	12 in (30 cm)	12 in (30 cm)
B =	Clearance to window or door that may be opened	6 in (15 cm) for appliances ≤ 10,000 Btu/h (3 kW), 12 in. (30 cm) for appliances >10,000 Btu/h (3 kW) and ≤ 100,000 Btu/h (30 kW), 36 in. (91 cm) for appliances >100,000 Btu/h (30 kW)	
C =	Clearance to permanently closed window	*	*
D =	Vertical clearance to ventilated soffit located above the terminal within a horizontal distance of 2 ft (61 cm) from the center line of the terminal	*	*
E =	Clearance to unventilated soffit	*	*
F =	Clearance to outside corner	*	*
G =	Clearance to inside corner	*	*
H =	Clearance to each side of center* line extended above meter/ regulator assembly	*	*
I =	Clearance to service regulator vent outlet	Above a regulator within 3 ft (91 cm) horizontally of the vertical center line of the regulator vent outlet to a maximum vertical distance of 15 ft (4.5m)	

	Description	Canadian installations	US installations ²
J =	Clearance to nonmechanical air supply inlet to building or the combustion air inlet to any other appliance	6 in (15 cm) for appliances ≤ 10,000 Btu/h (3 kW), 12 in (30 cm) for appliances >10,000 Btu/h (3 kW) and ≤ 100,000 Btu/h (30 kW), 36 in (91 cm) for appliances >100,000 Btu/h (30 kW)	
K =	Clearance to a mechanical air supply inlet	6 ft (1.83 m)	3 ft (91 cm) above if within 10 ft (3 m) horizontally
L =	Clearance above paved sidewalk or paved driveway located on public property	7 ft (2.13m) [1]	*
M =	Clearance under veranda, porch deck, or balcony	12 in (30 cm) [2]	*

[1] A vent shall not terminate directly above a sidewalk or paved driveway that is located between two single family dwellings and serves both dwellings.

[2] Permitted only if veranda, porch, deck, or balcony is fully open on a minimum of two sides beneath the floor.

* For clearances not specified in ANSI Z223.1/NFPA 54, clearances are in accordance with local installation codes and the requirements of the gas supplier.

Clearance to opposite wall is 24 inches (60 cm).

Additional clearances

Check to determine whether local codes supersede these clearances.

- Avoid termination locations near a dryer vent.
- Avoid termination locations near commercial cooking exhaust.
- Avoid termination locations near any air inlets.
- You must install a vent termination at least 12 inches above the ground or anticipated snow level.

The vent for this appliance shall not terminate:

- Over public walkways; or
- Near soffit vents or crawl space vents or other area where condensate or vapor could create a nuisance or hazard or cause property damage; or
- Where condensate or vapor could cause damage or could be detrimental to the operation of regulators, relief valves, or other equipment.

Important considerations for locating vent termination under a soffit (ventilated or unventilated or eave vent; or to a deck or porch)

- Do not install vent termination under a soffit vent such that exhaust can enter the soffit vent
- Install vent termination such that exhaust and rising moisture will not collect under eaves. Discoloration to the exterior of the building could occur if installed too close.
- Do not install the vent termination too close under the soffit where it could present recirculation of exhaust gases back into the combustion air intake part of the termination.



NOTICE

1. In accordance with the current CSA B149.1, Natural Gas and Propane Installation Code.
2. In accordance with the current ANSI Z223.1/NFPA 54, National Fuel Gas Code.
3. If locally adopted installation codes specify clearances different than those illustrated, then the most stringent clearance shall prevail.
4. For other than a direct vent appliance, the appliance must be located as close as practicable to a chimney or gas vent.

3.11 Venting Installation

Terminating the Vent

Before installing the water heater, determine what type of vent termination is appropriate for the installation location and situation. Examples in this section describe typical venting configurations, but they do not include all possible options.

The following installation guidelines can be used. Refer to the vent manufacturer's instructions for detailed installation procedures.

Horizontal Termination

Regions with cold climates will produce more condensate in the vent system. The condensate collector should be used in cold climates.

If more than one elbow is used in the vertical section, the condensate collector must be used.

* The condensate collector must also be used in horizontal terminations if a vertical rise in the vent system exceeds 5 ft.

Slope the vent 1/4 in. per foot downward toward the termination or upward if using a condensate collector as illustrated below.



WARNING

The air inlet cannot be covered.

Vertical Termination

Use a condensate collector in all installations.

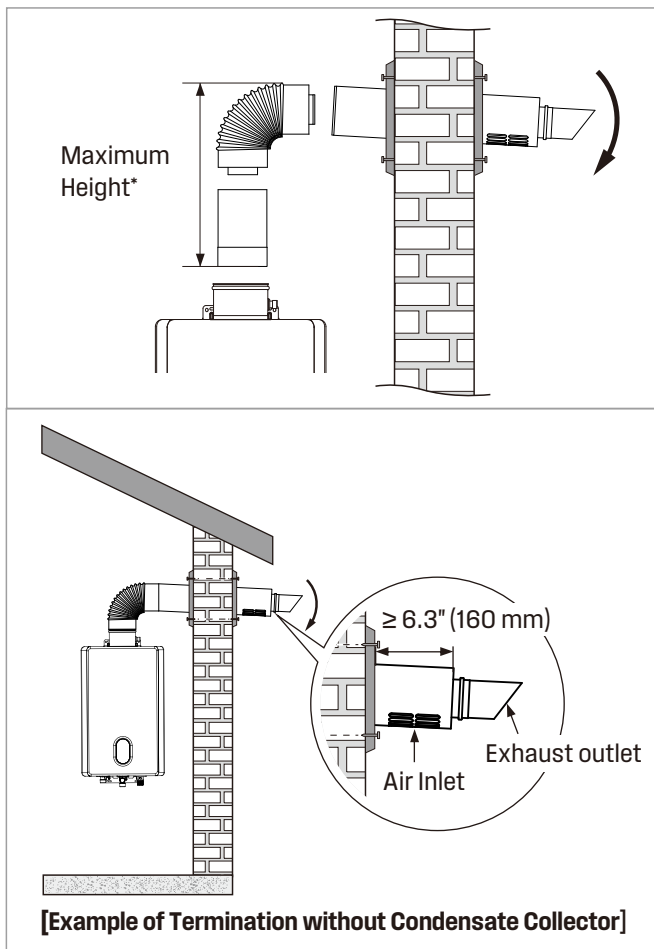
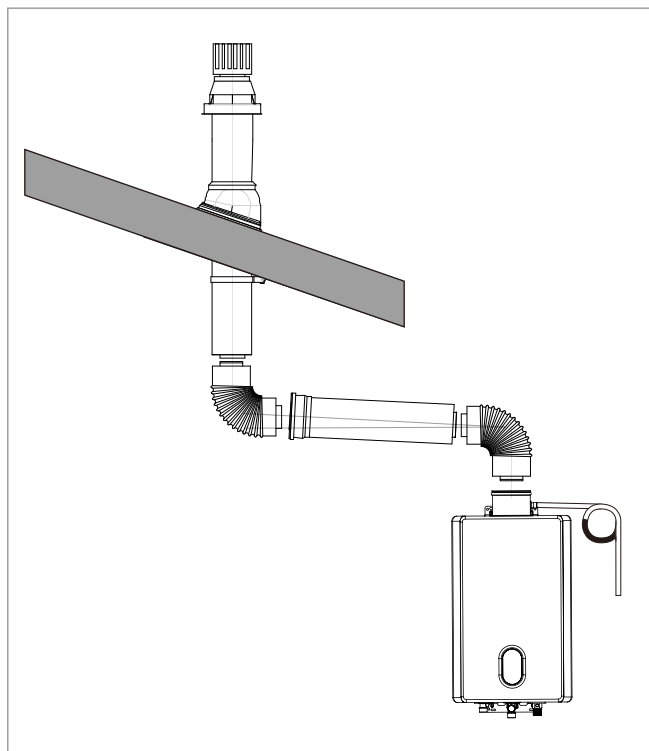
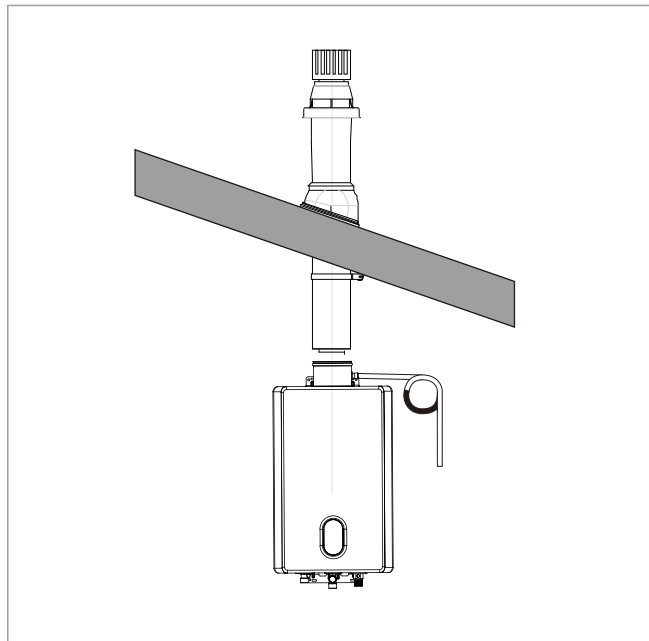

3.12 Condensate



WARNING

If a condensate trap hose is installed, the water inside the hose should be higher than 3 in. (75 mm), and water should be inside the hose before operating the water heater. Do not remove the condensate collector cap unless a condensate trap is attached.

If a condensate trap is not installed properly as explained above, it could result in injury or death.

Condensate can form in the vent of high efficiency direct vent appliances. Without proper drainage, condensate will damage the heat exchanger.

To prevent condensate damage, follow these instructions.

DO NOT

- DO NOT allow condensate to enter the water heater.
- DO NOT connect the condensate drain pipe directly to the rain sewer.
- DO NOT connect the condensate drain line with an air conditioning evaporator coil drain or.
- DO NOT connect the condensate drain line to the pressure relief valve/line of the appliance.

MUST DO

- Use only venting that is approved and identified as acceptable for your particular model.
- For vertical terminations, use the integrated condensate collector and install a condensate trap.
- Slope the venting toward the appliance according to the vent manufacturer's installation instructions.
- All condensate must drain and be disposed of according to local codes.
- Use only corrosion resistant materials for the condensate drain lines such as PVC pipe or plastic hose.
- The condensate drain pipe (along its entire length) must be at least the same diameter as the drain line, (5/8 inch).
- The end of the condensate drain pipe should be open to the atmosphere. The end should not be under water or other substances.
- To minimize freezing of the condensate, run the condensate drain line through an interior wall or between insulation and an interior wall.
- The condensate collector should be used for all combination domestic/hydronic heating applications.

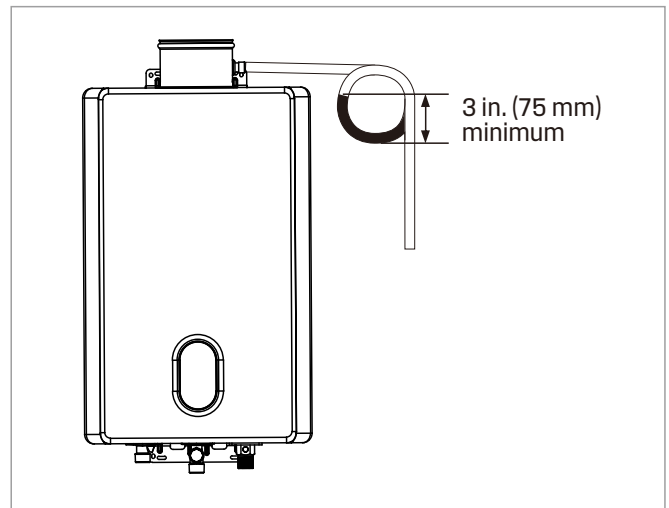

INFORMATION

- Regions of cold climate will create more condensate in the vent system. The condensate collector should be used in cold climates.
- The condensate drain pipe should be as short as possible and have a downward pitch.

3.13 Gas And Gas Pipe Specifications



WARNING

- First check that the gas type matches the nameplate.
- Make sure that all gas regulators in use are operating properly and provide gas pressure within the specified range as shown below. Excessive intake pressure can cause serious accidents.
- Failure to follow these warnings can result in serious personal injury, carbon monoxide poisoning or death.

- Maximum and minimum gas pressure:

Gas type	Intake pressure
Natural Gas	Min. 3.5" W.C. (0.87kPa) Max. 10.5" W.C. (2.61kPa)
Propane	Min. 8.0" W.C. (1.99kPa) Max. 13.0" W.C. (3.23kPa)

- Inlet gas pressures outside the above range of values may adversely affect the performance of the water heater. These pressures are measured when the water heater is fully operational.
- The intake pressure must not exceed the above maximum values; gas pressures outside the specified range will result in hazardous operating conditions and equipment damage.
- Be sure to disconnect the gas line from the water heater before the main gas supply pressure test is completed to avoid damaging the water heater.
- If the heater's supply pressure is greater than the specified maximum, a pressure regulator is required. The regulator must reduce the gas pressure to within acceptable limits.
- Install the gas regulator according to the manufacturer's instructions.
- The regulator must be sized for the water heater input and provided with the specified pressure listed on the nameplate.
- It is recommended that there be at least 3 ft (1 m) of tubing between the regulator outlet and the water inlet gas connection in the absence of a minimum installation distance.

3.14 Gas Connection



WARNING

- A trained and qualified professional must install the gas supply.
- Confirm the gas type before connecting. Failure to install the correct gas type may result in injury or damage to the water heater.
 - Turn off the 120V power supply.
 - Turn off the gas.
 - Gas is flammable. DO NOT smoke or provide other ignition sources while working with gas.
 - DO NOT turn on the water heater or gas until all fumes are gone.

1. Install a manual gas shut-off valve between the water heater and the air supply line.
2. When the gas connection is completed, the gas leak test must be performed by applying soapy water to all gas fittings and observing the air bubbles or using a gas leak detection device.
 - During any system stress test where the test pressure exceeds 1/2 psi (3.5 KPa), it must be the water heater and its separate shut-off valve are disconnected from the air supply piping system.
 - During pressure testing of any gas supply piping system with a test pressure equal to or less than 1/2 psi (3.5 KPa), the water heater must be isolated from the air supply piping system by closing its separate manual shut-off valve.
3. Always remove any debris and/or water gas lines before connecting to the air intake.



NOTICE

Do not use this product if any parts are underwater. Contact the installer or service agency immediately to replace the flooded water heater. Do not try to repair the heater. Replacement must be done!

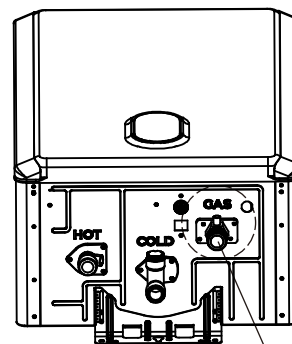

Gas connection 3/4 in. MNPT connection

3.15 Water Connection

Water Connection Guidelines



WARNING

Do not use this appliance if any part has been under water. Immediately contact a qualified installer or service agency to replace a flooded water heater. Do not attempt to repair the unit! It must be replaced!



NOTICE

Do not reverse the hot and cold inlet connections of the water heater. If connected in reverse, the water heater will not start properly.

Determine the type of water pipes in your home. Use fittings appropriate for the type of pipe in your home (copper, CPVC, or PEX). Do not use iron or PVC pipe - they are not suitable for potable water. All pipes, pipe fittings, valves, and other components, including soldering materials, must be suitable for potable water systems.

- A manual shutoff valve must be installed on the cold water inlet to the water heater between the main water supply line and the water heater.
- Connect the hot water supply using 3/4 inch NPT to the fitting marked HOT. Follow the same connection guidelines as for the cold water supply.
- In addition, a manual shutoff valve is also recommended on the hot water outlet.
- Double check to make sure the hot and cold water pipes are connected to the correct hot and cold water fittings on the water heater.
- If needed, install (or adjust) the home's pressure reducing valve.
- Before installing the water heater, flush the water line to remove all debris, and after installation is complete, purge the air from the line. Failure to do so may cause damage to the heater.
- Install insulation (or heat tape) on the water pipes, especially if the indoor installation area is subject to freezing temperatures. Insulating the hot water and return pipes will reduce heat loss.
- After installing the water heater, clean the inlet water filter that is located inside the cold water inlet, and then test the water heater for proper flow and inspect for leaks. Instruct the water heater owner that the filter must be cleaned periodically to maintain proper water flow.

3.16 Pressure Relief Valve

An approved pressure relief valve is required by the American National Standard (ANSI Z21.10.3) for all water heating systems and shall be accessible for servicing.

The water heater has a built-in high-temperature disconnect switch as a standard safety function (called a Hi-limit switch), so a "pressure-only" safety valve is required.

- This valve is not supplied, but is required.
- An approved pressure relief valve must be installed at the hot water outlet.
- The pressure relief valve must comply with ANSI Z21.22 • CSA 4.4. Installation must comply with local regulations.
- The pressure relief valve must be rated up to 150 psi and to at least the maximum Btu/hr of the appliance.
- The drain line of the pressure relief valve must be guided so that hot water does not splash out and cause damage or personal injury.
- Connect the drain hose to the pressure relief valve so that the end of the tube is 6 inches (152 mm) from the floor. The tube must be completely drained without any bends or blockages.
- If the pressure relief valve is periodically discharged, this may be due to thermal expansion.
- In the closed water supply system, please contact your water supplier or local plumbing professional to find out how to correct this situation. Do not block the pressure relief valve.
- The pressure relief valve must be manually operated periodically to check that it is operating correctly. Before manually operating the valve, check that the pressure relief valve is vented in a safe place.
- Do not place a valve between the safety valve and the water heater.

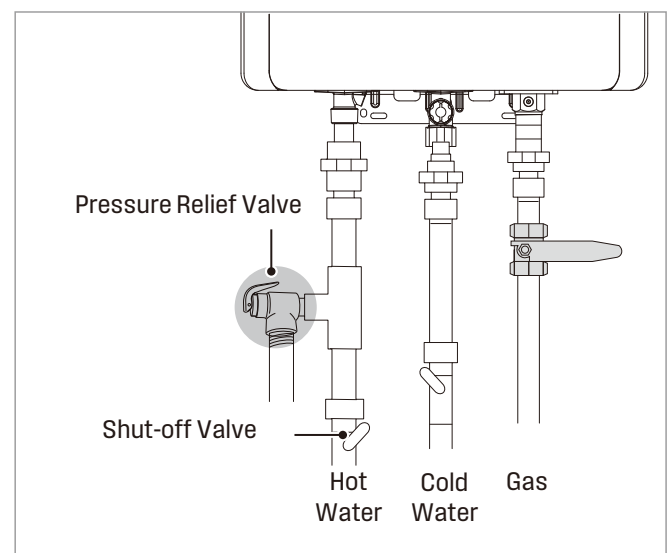

Pressure Relief Valve Maintenance:

For proper care of this approved pressure relief valve, it is recommended that the valve be manually operated once a year. In doing so, it will be necessary to take precautions with regard to the discharge of potentially scalding hot water under pressure. Ensure discharge water has a safe place to flow. Contact with your body or other property may cause damage or harm.

3.17 Connecting the Power Supply



WARNING: Electric Shock Hazard To prevent serious injury or death:

- ALWAYS follow all applicable electrical codes of the local authority having jurisdiction.
- In the absence of such requirements, follow the latest edition of the National Electrical Code (NFPA 70) in the USA or the latest edition of CSA C22.1, Canadian Electrical Code Part 1, in Canada.
- ONLY licensed professionals should connect the power supply.

When connecting the power supply, follow these guidelines:

- DO NOT rely on the gas or water piping to ground the water heater. Ground locations are provided inside the water heater.
- The water heater requires 120 V AC, 60 Hz power from a properly grounded circuit.
- If using the 5 ft (1.5 m) power cord (supplied with indoor water heaters), plug it into a standard 3-prong 120 V AC, 60 Hz properly grounded wall outlet.
- On external (outdoor) models, a proper disconnect (i.e., on/off switch, power cord, etc.) must be provided and installed for the incoming 120 V AC power. The switch should be a type that is suitable for outdoor use. Check the National Electrical Code, ANSI/NFPA 70, and your local codes for a proper switch type to use in your area. Power connections must be protected from the weather, and flexible cords must use an appropriate strain relief.
- The wiring diagram is located on the inside of the water heater front cover.

3.18 Initial Test Run



WARNING

For your safety, please read before operation.

- Check for leaks in the gas and water connections for the first time before the ignition.
- Open the main gas supply valve of the unit by hand only to avoid any sparks. Never use tools. If the knob does not turn by hand, do not attempt to force rotation; call a qualified service technician. Forced repairs may result in a fire or explosion due to a gas leak.
- Always check for leaks at the bottom of the unit, as some gases are heavier than air and may settle toward the floor.
- Check gas pressure. See "6.8 Gas pressure test position".
- Do not attempt to manually ignite the burner. It is equipped with an electronic ignition device that automatically ignites the burner.
- Check that the water heater is ventilated and that the flammable air is normal.
- Do not use this product if it is in contact with water or immersed in water. Contact a qualified installer or service facility immediately to replace the water heater. Do not attempt to repair the device! Must be replaced!









WARNING

If you smell the smell:

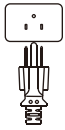
- Do not attempt to start the water heater.
- Do not touch any electric switch.
- Do not use any mobile phones in your building. Call your gas supplier immediately from your neighbor's phone. Follow the instructions of the gas supplier.
- If you are unable to contact your gas supplier, please call the fire department.
- Failure to follow these warnings can result in fire or explosion, resulting in serious injury or death.

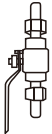
Installation

The user confirms that the water heater is installed correctly before the initial use, and carefully checks whether the connection is correct and there is no leakage. After confirming, please follow the steps below:

Initial Test Run		
1	Turn on the water heater's 120v, 60 Hz power supply.	
2	Remove debris from the inlet screen.	
3	Open the valve on the inlet water.	
4	Turn on the hot water tap, make sure there is water flowing out, then turn off the hot water tap.	
5	Open the manual gas valve.	
6	Press the switch button on the controller and set the desired hot water temperature.	
7	When you turn on the hot water tap, you can enjoy the constant flow of hot water.	