

3 Installation

3.1 Installation Instructions

1. Follow all local regulations, or in the absence of local regulations, follow the current version of the US National Gas Code: US ANSI Z 223. 1/NFPA 54 or Canada b 149. 1 natural gas, propane installation specifications.
2. All gas water heaters require proper and careful installation to ensure safe and efficient operation. This manual must be strictly observed.
3. The manifold pressure is preset at the factory. It is computer controlled and does not require adjustment.
4. Maintain proper maintenance space when installing equipment. So that it can be easily connected or removed.
5. The water heater must be installed in a place where it can be used at any time with a suitable amount of flammable air. The indoor water heater can be directly ventilated.
6. The electrical connection requires disconnecting the unit for maintenance and safety to turn off the power to the water heater.
7. Do not install the unit where the exhaust vents point to any openings in the building or where noise may disturb the neighbors. Ensure that the vent terminal meets the required distance from any door or opening by local regulations to prevent exhaust gases from entering the building.
8. Carefully select the installation location of the water heater, lint and fine powder Contaminants such as flour can block the air intake and reduce fan operation. This in turn, can lead to burning anomalies and shorten the life of the water heater. Regularly ensure that the area around the water heater the air inlet are free of dust, debris and other contaminants.
9. This water heater is for indoor installation only.
 - Only install the water heater in a heated area where the temperature cannot be below freezing. The warranty does not cover damage caused by freezing.
 - The water heater must be securely mounted to a wall or other suitable structure.
 - The water heater cannot be installed on the floor.



WARNING

Water temperatures above 125 °F (52 °C) can cause severe burns or burns. The factory water temperature is set at 107 °F (42 °C) to minimize the risk of burns. Always check the water temperature before taking a shower or shower.

Do not store or use gasoline or other flammable materials, vapors or liquids near this equipment.

Do not connect to water or gas connections as this can damage the valve and can cause serious injury or death.

Do not use this product if it is immersed in water. Call a qualified installer or service facility immediately to replace the water-immersed water heater. Do not attempt to repair the unit. Must be replaced.

Do not disconnect the power supply if the ambient temperature is below freezing. The frost protection system is only effective when the device has power. **If the heat exchanger is damaged due to freezing, it is not covered by the warranty.**

Failure to follow these warnings can result in serious personal injury or death.

**WARNING**

- Installation and repair must be performed by a qualified installer (for example, a licensed plumber or gas fitter) or the warranty will be void.
- The installer (authorized professional) is responsible for properly installing the water heater and complying with all national, state/provincial and local regulations.
- The manufacturer does not recommend installing the water heater in a pit or location where gas and water may accumulate.
- Do not point the vent to any operating window, door or opening to the building.
- Do not install any air debris (such as a dryer) that could cause debris to get trapped in the combustion chamber unless the system is directly ventilated.
- Do not install the unit in water, debris or flammable vapors that may enter the flue terminal or intake line.
- Due to safety issues, the manufacturer does not recommend installing the water heater in the attic.

**WARNING**

- Make sure the equipment has adequate combustion air and proper ventilation. Failure to do so may result in carbon monoxide poisoning or death.
- Keep the area around the water heater clean. When the dust collects on the flame, the sensor will turn off the error code.
- Place the equipment for easy repair and maintenance.
- If a leak occurs, it is recommended to install a drain pan or other waterproof protection under the water heater.
- Failure to follow these warnings can result in serious personal injury, death and/or property damage.

**NOTICE**

- The warranty does not cover damage caused by water quality.
- This water heater can only use potable water. Do not introduce pool or hot spring water or any chemically treated water into the water heater.
- For all other types of applications, the water hardness level for single-family applications should not exceed 7 grains per gallon (120 ppm) or 4 grains (70 ppm) per gallon. The hardness of the water can cause scaling and can affect/damage the water heater. Hard scale must be avoided or controlled by proper water treatment.
- The pH of the water must be between 6.5 and 8.5.
- Well water must be disposed of.
- When the water heater is installed in a beauty salon, dry cleaner or in the air, there is such a chemical. Whenever any other location, the manufacturer recommends direct venting. Certain chemicals used in beauty salons or dry cleaners may affect the flame sensor. In this case underneath, the water heater may not work properly.
- Although the water heater is designed to operate with minimal sound, the manufacturer does not recommend installing the unit on a wall close to the bedroom or in a room for quiet study or meditation.
- Place the heater near the drain and the water will not damage the surrounding area. As with any water heating device, there is a real possibility of leakage at certain times during the life of the product. The manufacturer is not responsible for any water damage that may occur. If you install a drain pan under the unit, make sure it does not restrict the flow of combustion air.

3.2 Installation Checklist

- Unbox and check whether the water heater, installation manual and owner's guide, parts and accessories bag, are coming in the box.
- Check to ensure there are no corrosive chemicals in the air intake.
- Water supply should be free of chemicals, and water hardness that higher than allowed level may damage the water heater.
- Ensure there is enough space required for installation.
- Ensure there is enough distance required between the exhaust vent and air inlet of houses.
- Ensure you are using the right exhaust vent products, and follow the installation manual from the suppliers.
- For indoor water heater models, ensure the number of elbows used does not exceed the maximum quantity allowed, and the exhaust vent pipe's total length (including the elbows, each is equivalent to 6 feet) does not exceed the maximum length allowed for the water heater.
- Slope horizontal exhaust run towards the water heater 1/4 in. per foot (21 mm per meter). DO NOT slope intake air pipe towards water heater.
- Turn off hot water switch, turn on cold water switch and the drain screw, flush the debris and air out of the water pipes. Debris inside the water my damage the water heater. Please use buckets or extra water pipes if needed.
- Ensure no water leakages.
- Turn off cold and hot water switches before cleaning up water inlet filter. Put a bucket under the water heater's filter to catch any water out of the water heater. Screw out the water inlet filter, wash off debris and dusts, and then hand screw the filter back in. When it's done, turn on the cold and hot water switches.
- Ensure the pressure relieve valve's relieving capacity exceeds that of the water heater BTU input rating. Please refer to the specifications on the side of machine for BTU input ratings.
- Install a manual gas shut-off valve between the water heater and your gas supply line.
- Check to confirm there is no gas leakage in piping and fittings.
- Confirm the gas inlet pressure in the min-max range as required.
- Confirm you are using the gas type as required by the water heater.
- Confirm the power supply is 120 V/60 Hz, and properly grounded.
- Confirm the thermostat works normally.
- Connect a gas manometer to the pressure port to verify the system is working normally. Turn on appliances that use high flow rate hot water and set the water heater to its maximum operation capacity, the inlet gas pressure must be higher than the minimum pressure on the specification label.
- Do not induct poisonous chemicals into drinking water, like the chemicals used to process broiler water.
- Drain the water out of the water heater if you are not using the water heater for a significant time period.

3.3 Prepare for installation

Recommends that the following tools be used while installing the Water Heaters.

■ Parts included

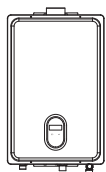

Tankless
Water Heater



User Manual



Assembly Kit

■ Tools needed (Not included)



Screw Driver



Pipe Wrench



Wrench

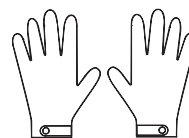

Gloves



Safety Glasses



Levelling
Instrument

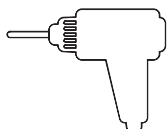

Hammer Drill
With Concrete Bits



Soapy Water

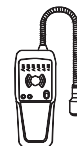

Gas Leak Detector



Ruler

■ Materials needed (Not included)



Teflon Tape

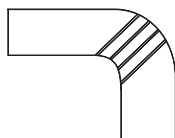

Approved Venting



Pressure Relief Valve

■ Materials that may be needed (Not included)

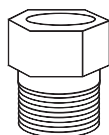

NPT3/4-in x 1/2-in dia
Threaded Male Adapter

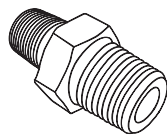

1/2"Hex Nipple

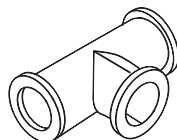

Threaded Tee Fitting
(Middle 3/4")

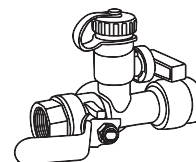

Hot Water
Isolation Valve

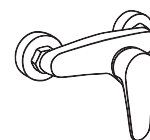

Thermostatic
Mixing Valve

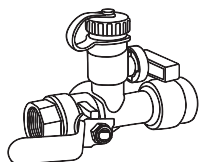

Cold Water
Isolation Valve

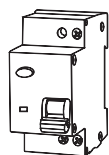

Single gang
electrical box



Electrical
Adhesive Tape

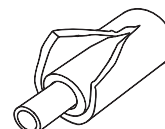

Pipe Wrap
Insulation

3.4 Determine Installation Location



WARNING

- DO NOT Install in areas where air for combustion can be contaminated with chemicals.
- Before installation, consider where air has the ability to travel within the building to the water heater.
- Make sure the equipment has adequate combustion air and proper ventilation. Failure to do so may result in carbon monoxide poisoning or death.
- Chemicals that are corrosive in nature should not be stored or used near the water heater.



WARNING

- Install the water heater as far away as possible from exhaust vent hoods.
- Install as far away as possible from air inlet vents. Corrosive fumes may be released through these vents when air is not being brought in through them.
- Chemicals that are corrosive in nature should not be stored or used near the water heater or vent termination.

You must ensure that clearances will be met and that the vent length will be within required limits. Consider the installation environment, water quality, and need for freeze protection. Requirements for the gas line, water lines, electrical connection, and condensate disposal can be found in their respective installation sections of this manual.

Water quality

Consideration of care for your water heater should include evaluation of water quality.

The water must be potable, free of corrosive chemicals, sand, dirt, or other contaminants. It is up to the installer to ensure the water does not contain corrosive chemicals, or elements that can affect or damage the heat exchanger. Water that contains chemicals exceeding the levels below affect and damage the heat exchanger. Replacement of the heat exchanger due to water quality damage is not covered by the warranty.

Environment

Air surrounding the water heater, venting, and vent termination(s) is used for combustion and must be free of any compounds that cause corrosion of internal components. These include corrosive compounds that are found in aerosol sprays, detergents, bleaches, cleaning solvents, oil based paints/ varnishes, and refrigerants. The air in beauty shops, dry cleaning stores, photo processing labs, and storage areas for pool supplies often contains these compounds.

Therefore it is recommended that outdoor models be used for these locations where possible.

The water heater, venting, and vent termination(s) should not be installed in any areas where the air may contain these corrosive compounds. If it is necessary for a water heater to be located in areas which may contain corrosive compounds, the following instructions are strongly recommended.

IMPORTANT CONSIDERATIONS FOR:

Indoor Water Heaters

- DO NOT Install in areas where air for combustion might be contaminated with chemicals.
- Before installation, consider where air has the ability to travel within the building to the water heater.
- Where possible, install the water heater in a sealed closet so that it is protected from the potential of contaminated indoor air.
- Chemicals that are corrosive in nature should not be stored or used near the water heater.

3.5 Venting Guidelines

Inspection

Before installation inspect each vent component for damage and correct seal placement. Do not attempt to fix or install any damaged vent components.

DO NOT

- Do not use cellular core PVC/CPVC.
- Do not use Radel, ABS, or galvanized material to vent this appliance.
- Do not cover non-metallic vent pipe and fittings with thermal insulation.
- Do not combine vent components from different manufacturers.
- Vent diameter must not be reduced.
- Do not connect the venting system with an existing vent or chimney.
- Do not common vent.

MUST DO

- This water heater is a direct vent water heater and therefore is certified and listed with the vent system. You must use vent components that are certified and listed with the water heater model.
- The vent system must vent directly to the outside of the building and use outside air for combustion.
- Avoid dips or sags in horizontal vent runs by installing supports per the vent manufacturer's instructions.
- Support horizontal vent runs every four feet and all vertical vent runs every six feet or in accordance with local codes.
- Venting should be as direct as possible with a minimum number of pipe fittings.
- Vent connections must be firmly pressed together so that the gaskets form an air tight seal.
- The vent piece connected to the water heater must be secured with one self-tapping screw.

3.6 Exhaust Pipe Specifications

- The maximum length of exhaust vent piping must not exceed 25 ft (7.5 m) for 3" (76.2 mm) venting, which depends on the elevation where the water heater is installed, Do not use more than 4 elbows. See the table below.
- When the horizontal vent run exceeds 5 ft (1.5 m), support the vent run at 3 ft (0.9 m) intervals with overhead hangers.

Diameter	3 in (76mm)
Max. No. of Elbows (Number of 90° Elbows)	3
Max. Vertical and Horizontal (Total) Vent Length	25 ft (7.5m)

* For each elbow added, deduct 6 ft (1.8 m) from max. v ent length.

No. of Elbows (Number of 90° Elbows)	Max. Vertical or Horizontal (Total) Vent Length
	3"(76.2mm) Straight tube length Altitudes 0 to 3,000 ft (0 to 914 m)
0	25 ft (7.5 m)
1	20 ft (6 m)
2	14 ft (4.5m)
3	8 ft (2 m)

* Length include vent terminators, termination elbows, or rain caps.

INFORMATION

- Refer to the instructions of the vent system manufacturer for component assembly instructions.
- If the vent system is to be enclosed, it is suggested that the design of the enclosure permit inspection of the vent system. The design of such enclosure shall be deemed acceptable by the installer or the local inspector.

3.7 Venting Instructions



WARNING

- Improper installation of ventilation on this equipment can result in excessive carbon levels and carbon monoxide can cause severe personal injury or death.
- Improper installation can result in nausea or suffocation, serious injury or death from carbon monoxide and smoke poisoning. Improper installation will void the product warranty.

Indoor models must be vented according to the current version of the National Gas Code "Equipment Exhaust" section: US ANSI z 223.1/NFPA 54 and/or B 149.1 natural gas section 8 Canadian propane and propane installation specifications, And applicable local building codes.

General rules for venting water heaters:

- Place the water heater as close as possible to the vent termination.
- Exhaust pipe must be easily removed from the top of the water heater for proper service and inspection.
- Avoid using oversized exhaust pipes or using extremely long pipes unless it is part of an approved general exhaust system.
- For roof ventilation, a rain cap or other form of terminal must be installed to prevent rain from entering indoor.
- A water heater shall not be connected to a chimney flue serving a separate appliance, designed to burn solid fuel.
- Provisions for adequate combustion and ventilation air in accordance with one of the following:
 - A) The National Fuel Gas Code, ANSI Z223.1/NFPA 54.
 - B) CSA B149.1, Natural Gas and Propane Installation Code.
 - C) Applicable provisions of the local building code.
- Minimum clearances from combustible or noncombustible construction, 6 inches sides, 0 inches back, and 12 inches top. Minimum clearance from Type B flue or vent connector to combustible construction 1 inches. Type B Vent or Vent connector shall be used.

- When the appliance is installed directly on carpeting, the appliance shall be installed on a metal or wood panel extending beyond the full width and depth of the appliance by at least 3 in (76.2 mm) in any direction or, if the appliance is installed in an alcove or closet, the entire floor shall be covered by the panel. The panel must be strong enough to carry the weight of the heater when running.

• General rules for the termination of vents:

- The water heater should not be connected to the chimney flue of a separate unit used to burn solid fuel.
- Avoid placing the water heater exhaust terminal near any indoor air intake. These fans can take the exhaust flue products out of the water heater and return them to the building. This can be harmful to your health.
- Locate the exhaust terminal so that it will not be blocked by any debris at all times. Most specifications require the terminal to be at least 12 inches (305 mm) above grade and the expected snow level, but the installer can determine if it should be higher based on job site conditions and applicable specifications.



CAUTION

Label all wires prior to disconnection when servicing controls. Wiring errors can cause improper and dangerous operation. Verify proper operation after servicing.

■ Installation space



WARNING

Keep all the space around the water heater. Failure to do so may result in fire and may result in death, injury and or property loss.

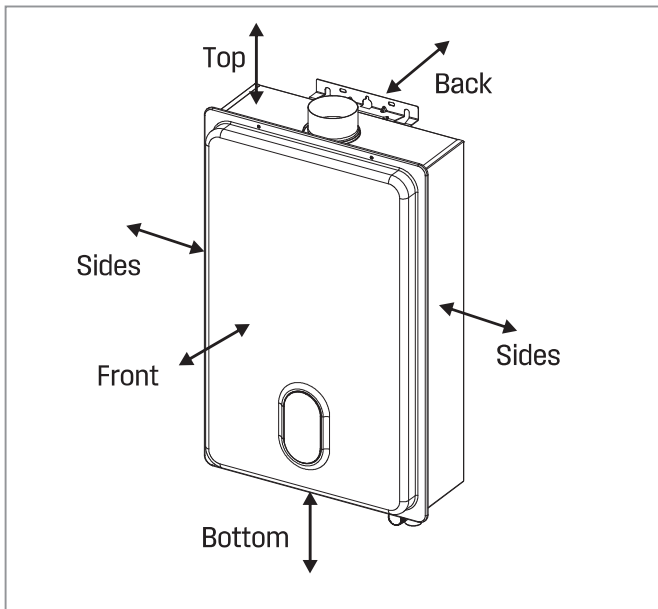

Minimum clearances from combustible or noncombustible construction and for servicing and proper operation:

Top	Bottom	Front	Back	Sides
12 in (305mm)	12 in (305mm)	24 in (610mm)	0 in (0mm)	6 in (150mm)

3.8 Direct Vent Terminal Clearances (Indoor Units)

For indoor models, you must install a vent termination to bring in combustion air and expel exhaust to the outside.

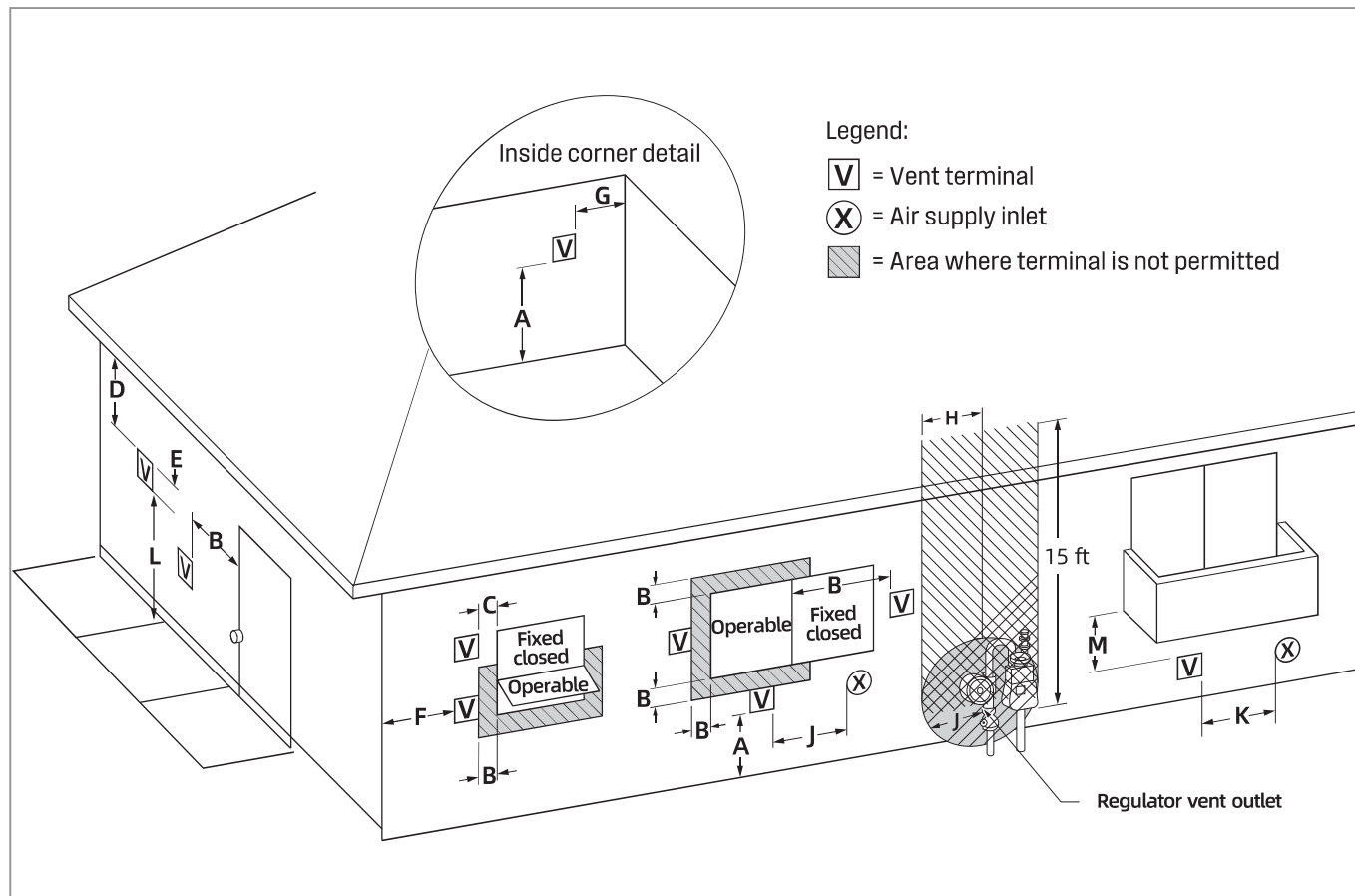

	Description	Canadian installations	US installations ²
A =	Clearance above grade, veranda, porch, deck, or balcony	12 in (30 cm)	12 in (30 cm)
B =	Clearance to window or door that may be opened	6 in (15 cm) for appliances ≤ 10,000 Btu/h (3 kW), 12 in. (30 cm) for appliances >10,000 Btu/h (3 kW) and ≤ 100,000 Btu/h (30 kW), 36 in. (91 cm) for appliances >100,000 Btu/h (30 kW)	
C =	Clearance to permanently closed window	*	*
D =	Vertical clearance to ventilated soffit located above the terminal within a horizontal distance of 2 ft (61 cm) from the center line of the terminal	*	*
E =	Clearance to unventilated soffit	*	*
F =	Clearance to outside corner	*	*
G =	Clearance to inside corner	*	*

	Description	Canadian installations	US installations ²
H =	Clearance to each side of center line extended above meter/regulator assembly	*	*
I =	Clearance to service regulator vent outlet	Above a regulator within 3 ft (91 cm) horizontally of the vertical center line of the regulator vent outlet to a maximum vertical distance of 15 ft (4.5m)	*
J =	Clearance to nonmechanical air supply inlet to building or the combustion air inlet to any other appliance	6 in (15 cm) for appliances ≤ 10,000 Btu/h (3 kW), 12 in (30 cm) for appliances >10,000 Btu/h (3 kW) and ≤ 100,000 Btu/h (30 kW), 36 in (91 cm) for appliances >100,000 Btu/h (30 kW)	
K =	Clearance to a mechanical air supply inlet	6 ft (1.83 m)	3 ft (91 cm) above if within 10 ft (3 m) horizontally
L =	Clearance above paved sidewalk or paved driveway located on public property	7 ft (2.13m) [1]	*
M =	Clearance under veranda, porch deck, or balcony	12 in (30 cm) [2]	*

[1] A vent shall not terminate directly above a sidewalk or paved driveway that is located between two single family dwellings and serves both dwellings.

[2] Permitted only if veranda, porch, deck, or balcony is fully open on a minimum of two sides beneath the floor.

* For clearances not specified in ANSI Z223.1/NFPA 54, clearances are in accordance with local installation codes and the requirements of the gas supplier.

Clearance to opposite wall is 24 inches (60 cm).

Additional clearances

Check to determine whether local codes supersede these clearances.

- Avoid termination locations near a dryer vent.
- Avoid termination locations near commercial cooking exhaust.
- Avoid termination locations near any air inlets.
- You must install a vent termination at least 12 inches above the ground or anticipated snow level.

The vent for this appliance shall not terminate

- Over public walkways; or
- Near soffit vents or crawl space vents or other area where condensate or vapor could create a nuisance or hazard or cause property damage; or
- Where condensate or vapor could cause damage or could be detrimental to the operation of regulators, relief valves, or other equipment. Important considerations for locating vent termination under a soffit (ventilated or unventilated or eave vent; or to a deck or porch)
- Do not install vent termination under a soffit vent such that exhaust can enter the soffit vent
- Install vent termination such that exhaust and rising moisture will not collect under eaves. Discoloration to the exterior of the building could occur if installed too close.
- Do not install the vent termination too close under the soffit where it could present recirculation of exhaust gases back into the combustion air intake part of the termination.



NOTICE

1. In accordance with the current CSA B149.1, Natural Gas and Propane Installation Code.
2. In accordance with the current ANSI Z223.1/NFPA 54, National Fuel Gas Code.
3. If locally adopted installation codes specify clearances different than those illustrated, then the most stringent clearance shall prevail.
4. For other than a direct vent appliance, the appliance must be located as close as practicable to a chimney or gas vent.
5. The appliance should be located in an area where leakage of the tank or connections will not result in damage to the area adjacent to the appliance or to

lower floors of the structure. When such locations cannot be avoided, it is recommended that a suitable drain pan, adequately drained, be installed under the appliance. The pan must not restrict combustion air flow.

3.9 Mount to Wall

1. Identify the installation location and confirm that the installation will meet all required clearances.



NOTICE

The water heater must be installed in an upright position. Do not install upside down or on its side.

2. As shown on the right, first install the mounting hole on the wall. The upper mounting hole is fixed by the expansion screw, and the lower mounting hole is inserted into the plastic plug. Hang the water heater, place the washer and nut on top, and tighten the nut. Screw on the self-tapping screws below.

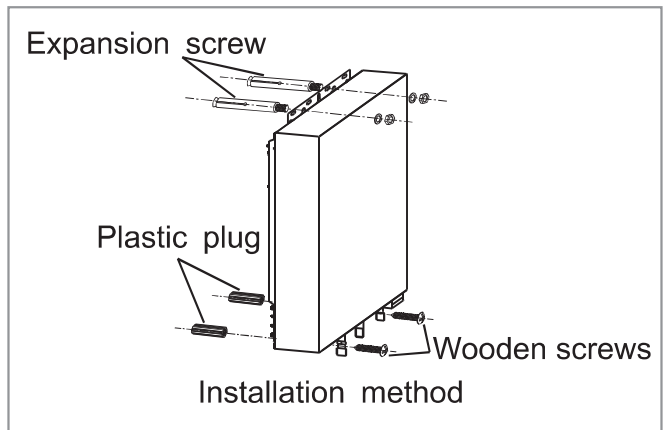

3.10 Venting Installation

Precautions for installation of exhaust pipe:

1. The exhaust pipe must be installed when the water heater is used.
2. The elbow and the straight pipe are combined into a smoke exhaust pipe. One elbow is equivalent to 6 ft. But the total length of elbows and straight pipe must not exceed 25 ft (7.5m).

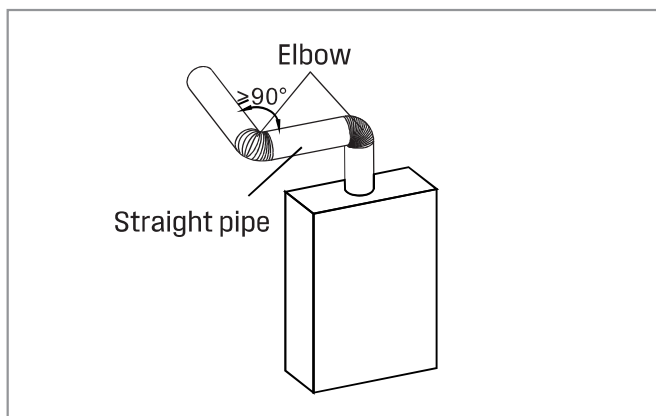

3. The installation of gas water heater pipe should be outward and downward the slope of 3° is such that when the outdoor temperature is too low, the condensed water does not flow back into the interior of the water heater.

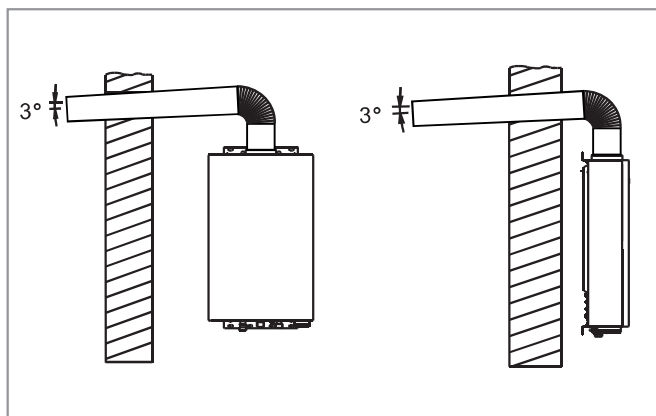

WARNING

It is absolutely forbidden to use this water heater without installing a smoke exhaust pipe.

4. When the flue passes through a wall made of combustible materials, it must be covered with an insulating flame retardant material greater than 1 inch thick.
5. The flue should not be hidden in the ceiling as much as possible. If it is unavoidable, it needs to be wrapped with flame-retardant insulation material, covering a thickness of 1 inch or more. The distance from the flue to the combustible item should be greater than 1 ft.
6. The gap between the flue and the round hole in the wall through which it passes cannot be permanently filled with cement to facilitate maintenance.
7. The exhaust vents shall not be installed in the ventilation of the building and on the common flue.

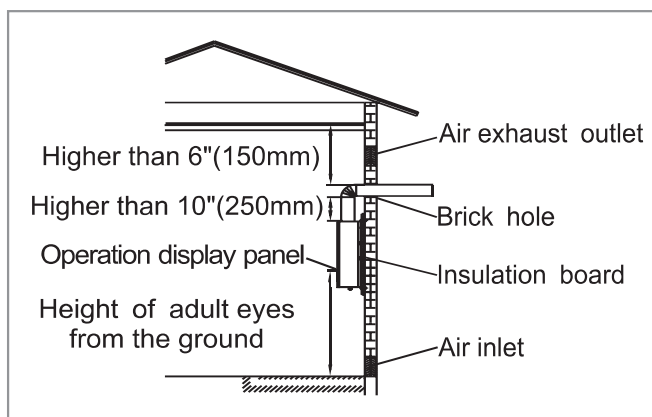

3.11 Condensate

Condensate can form in the vent of high efficiency direct vent appliances. Without proper drainage, condensate will damage the heat exchanger.

To prevent condensate damage, follow these instructions.

DO NOT

- DO NOT allow condensate to enter the water heater.
- DO NOT connect the condensate drain pipe directly to the rain sewer.
- DO NOT connect the condensate drain line with an air conditioning evaporator coil drain or.
- DO NOT connect the condensate drain line to the pressure relief valve/line of the appliance.

MUST DO

- Use only venting that is approved and identified as acceptable for your particular model.
- For vertical terminations, use the integrated condensate collector and install a condensate trap.
- Slope the venting toward the appliance according to the vent manufacturer’s installation instructions.
- All condensate must drain and be disposed of according to local codes.
- Use only corrosion resistant materials for the condensate drain lines such as PVC pipe or plastic hose.
- The condensate drain pipe (along its entire length) must be at least the same diameter as the drain line, (5/8 inch).
- The end of the condensate drain pipe should be open to the atmosphere. The end should not be under water or other substances.
- To minimize freezing of the condensate, run the condensate drain line through an interior wall or between insulation and an interior wall.
- The condensate collector should be used for all combination domestic/hydronic heating applications.

INFORMATION

- Regions of cold climate will create more condensate in the vent system. The condensate collector should be used in cold climates.
- The condensate drain pipe should be as short as possible and have a downward pitch.

3.12 Gas And Gas Pipe Specifications



WARNING

- First check that the gas type matches the nameplate.
- Make sure that all gas regulators in use are operating properly and provide gas pressure within the specified range as shown below. Excessive intake pressure can cause serious accidents.
- Failure to follow these warnings can result in serious personal injury, carbon monoxide poisoning or death.

- Maximum and minimum gas pressure:

Gas type	Intake pressure
Natural Gas	Min. 3.5" W.C. (0.87kPa) Max. 10.5" W.C. (2.61kPa)
Propane	Min. 8.0" W.C. (1.99kPa) Max. 13.0" W.C. (3.23kPa)

- Inlet gas pressures outside the above range of values may adversely affect the performance of the water heater. These pressures are measured when the water heater is fully operational.
- The intake pressure must not exceed the above maximum values; gas pressures outside the specified range will result in hazardous operating conditions and equipment damage.
- Be sure to disconnect the gas line from the water heater before the main gas supply pressure test is completed to avoid damaging the water heater.
- If the heater's supply pressure is greater than the specified maximum, a pressure regulator is required. The regulator must reduce the gas pressure to within acceptable limits.
- Install the gas regulator according to the manufacturer's instructions.
- The regulator must be sized for the water heater input and provided with the specified pressure listed on the nameplate.
- It is recommended that there be at least 3 ft (1 m) of tubing between the regulator outlet and the water inlet gas connection in the absence of a minimum installation distance.

3.13 Gas Connection



WARNING

1. A licensed professional must install the gas supply.
2. Turn off 120v power supply.
3. Turn off the gas.
4. Gas is flammable. Do not smoke or provide other ignition sources while working with gas.
5. Do not turn on the water heater or gas until all fumes are gone.

1. Install a manual gas shut-off valve between the water heater and the air supply line.
2. When the gas connection is completed, the gas leak test must be performed by applying soapy water to all gas fittings and observing the air bubbles or using a gas leak detection device.
 - During any system stress test where the test pressure exceeds 1/2 psi (3.5 KPa), it must be the water heater and its separate shut-off valve are disconnected from the air supply piping system.
 - During pressure testing of any gas supply piping system with a test pressure equal to or less than 1/2 psi (3.5 KPa), the water heater must be isolated from the air supply piping system by closing its separate manual shut-off valve.
3. Always remove any debris and/or water gas lines before connecting to the air intake.



NOTICE

Do not use this product if any parts are underwater. Contact the installer or service agency immediately to replace the flooded water heater. Do not try to repair the heater. Replacement must be done!

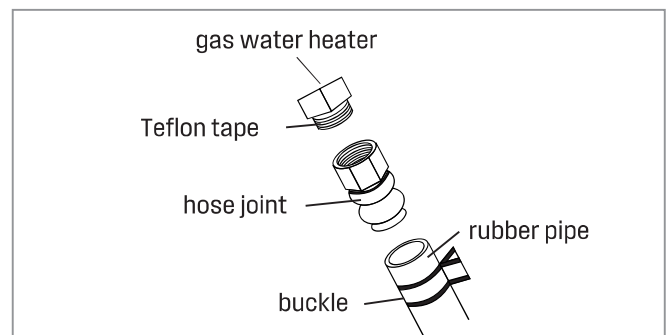
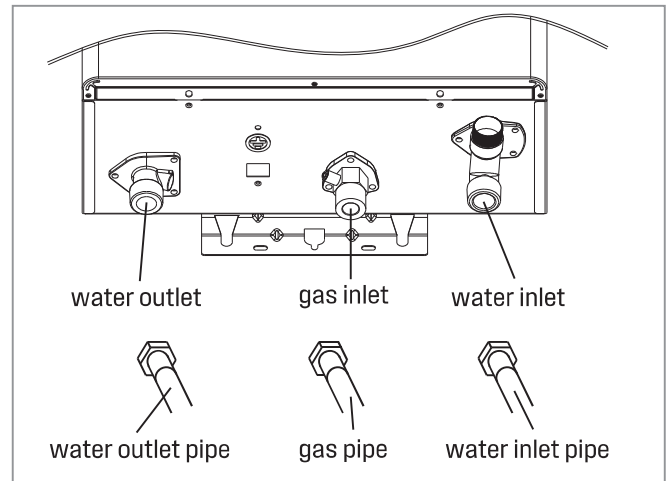

NOTICE

Use sealant tape or other approved sealing method on the threads for a secure, no water or gas leakage.

3.14 Water Connection



WARNING

Do not use this product if any parts are underwater. Contact the installer or service agency immediately to replace the flooded water heater. Do not try to repair the heater. Replacement must be done!



NOTICE

Do not reverse the hot and cold inlet connections of the water heater. If connected in reverse, the water heater will not start properly.

1. All piping, fittings, valves and other components, including welding materials, must be suitable for drinking water systems.
2. The on/off valve must be installed in the cold water inlet of the water heater between the main water supply line and the water heater.
3. Flush the water line to remove any debris before installing the water heater.
4. There is a wire mesh filter in the cold water inlet for filtering debris into the heater. This requires regular cleaning to maintain optimal flow.

3.15 Pressure Relief Valve

The water heater has a built-in high temperature disconnect switch as a standard safety function (called a Hi-limit switch), so a "pressure only" safety valve is required.

- The unit is not equipped with an approved pressure reducing valve.
- An approved pressure relief valve must be installed at the hot water outlet.
- The pressure relief valve must comply with ANSI Z 21.22 • CSA 4.4. Installation must comply with local regulations.
- The pressure relief valve must be rated up to 150 psi and to at least the maximum Btu/hr of the appliance.
- The drain line of the pressure reducing valve must be guided so that hot water does not splash out and cause damage or personal injury.
- Connect the drain hose to the pressure relief valve so that the end of the tube is 6 inches (152 mm) from the floor. The tube must be completely drained without any bends or blockages.
- If the pressure relief valve is periodically discharged, this may be due to thermal expansion.
- In the closed water supply system. Please contact your water supplier or local plumbing professional to find out how to correct this situation. Do not block the pressure relief valve.
- The pressure relief valve must be manually operated periodically to check that it is operating correctly. Before manually operating the valve, check that the pressure relief valve is vented in a safe place.
- Do not place a valve between the safety valve and the water heater.

3.16 Electrical Connections



WARNING

- Comply with the electrical code requirements of local authorities with jurisdiction. If there is no such requirement, please follow the current version of the National Electrical Code ANSI/NFPA 70 or the current Canadian version of CSA C22.1 Canadian Electrical Code Part 1.
- When repairing or replacing parts in the water heater, mark all wires before Disconnect to make it easy to reconnect. Incorrect wiring can result in incorrect and dangerous operation. Confirm correct operation after repair.
- Failure to follow these warnings can result in personal injury or death.

1. The water heater must be grounded. Do not connect the ground wire to a gas or water pipe.
2. The water heater requires a 120 VAC, 60 Hz power supply and is properly grounded.
 - For maintenance reasons, appropriate disconnects (i.e. on/off switches, power plugs, etc.) must be provided to control the main power supply to the water heater. (Must comply with local regulations.)
 - Connect the power supply to the water heater exactly as shown in the wiring diagram.
3. The plug of the water heater is not plugged into the standard American three-pin plug, and the socket must be properly grounded.
4. A surge protector is recommended to protect the equipment from power surges.

3.17 Initial Test Run



WARNING

For your safety, please read before operation.

- Check for leaks in the gas and water connections for the first time before the ignition.
- Open the main gas supply valve of the unit by hand only to avoid any sparks. Never use tools. If the knob does not turn by hand, do not attempt to force rotation; call a qualified service technician. Forced repairs may result in a fire or explosion due to a gas leak.
- Always check for leaks at the bottom of the unit, as some gases are heavier than air and may settle toward the floor.
- Check gas pressure. See "6.8 Gas pressure test position".
- Do not attempt to manually ignite the burner. It is equipped with an electronic ignition device that automatically ignites the burner.
- Check that the water heater is ventilated and that the flammable air is normal.
- Do not use this product if it is in contact with water or immersed in water. Contact a qualified installer or service facility immediately to replace the water heater. Do not attempt to repair the device! Must be replaced!



WARNING

If you smell the smell:

- Do not attempt to start the water heater.
- Do not touch any electric switch.
- Do not use any mobile phones in your building. Call your gas supplier immediately from your neighbor's phone. Follow the instructions of the gas supplier.
- If you are unable to contact your gas supplier, please call the fire department.
- Failure to follow these warnings can result in fire or explosion, resulting in serious injury or death.

The user confirms that the water heater is installed correctly before the initial use, and carefully checks whether the connection is correct and there is no leakage. After confirming, please follow the steps below:

Initial Test Run		
1	Turn on the water heater's 120v, 60 Hz power supply.	
2	Remove debris from the inlet screen.	
3	Open the valve on the inlet water.	
4	Turn on the hot water tap, make sure there is water flowing out, then turn off the hot water tap.	
5	Open the manual gas valve.	
6	Press the switch button on the controller and set the desired hot water temperature.	
7	When you turn on the hot water tap, you can enjoy the constant flow of hot water.	