

# 6 Maintenance

The water heater should be checked at least once a year or as necessary by a licensed technician. If repairs are needed, any repairs should be done by a licensed technician. The water heater's lifetime may be extended by regular maintenance.



### WARNING

- Turn off the electrical power supply and close the manual gas control valve and the manual water control valve before servicing.
- Label all wires prior to disconnection when servicing controls. Wiring errors can cause improper and dangerous operation.
- Verify proper operation after servicing.
- Should overheating occur or the gas supply fails to shut off, turn off the manual gas control valve to the appliance.

- Have a bucket or container to catch the water from the unit's drain plugs. Unscrew the drain plugs to drain all the water out of the unit.
- Wait a few minutes to ensure all water has completely drained from unit.

### Clean the filter:

- Check the water filter located within the cold inlet. With a tiny brush, clean the water filter of any debris which may have accumulated and reinsert the filter back into the cold water inlet.
- Securely screw the drain plugs back into place. Hand-tighten only.

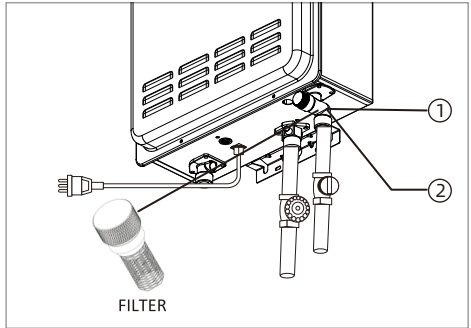

- ① Remove by turning counter clockwise and then clean and replace.
- ② 1. Turn off the water inlet supply valve.  
2. Open a hot water tap to release the line pressure.

## 6.1 Vent System

- Be sure that all openings for combustion air are not blocked. If blocked, remove obstruction.
- Check that the opening for exhaust is not blocked. If blocked, shutoff the water heater's combustion. And then after a while, remove obstruction.
- DO NOT touch while unit operating, otherwise you might get burnt due to high temperature.
- Check the gas pressure.
- Keep the area around the water heater clear. Remove any combustible materials, gasoline or any flammable vapors and liquids.
- Not obstructing the flow of combustion and ventilation air.

## 6.3 Clean Burners

It is imperative that control compartments, burners, and circulating air passageways of the appliance be kept clean.

Clean as follows:

1. Turn off and disconnect electrical power. Allow to cool.
2. Close the water shut off valves. Remove and clean the water inlet filter.
3. Remove the front panel by removing 4 screws.
4. Use pressurized air to remove dust from the main burner, heat exchanger, and fan blades. Do not use a wet cloth or spray cleaners on the burner.  
  
Do not use volatile substances such as benzene and thinners. They may ignite or fade the paint.
5. Use soft dry cloth to wipe cabinet.

## 6.2 Unit Draining and Filter Cleaning

- Close the manual gas shut off valve.
- Turn off the power supply to the water heater.
- Close the manual water shut off valve.
- Open all hot water taps in the house (Bathroom, kitchen, laundry, etc.). When the residual water flow has ceased, close all hot water taps.

## 6.4 Visual Inspection of Flame

Verify proper operation after servicing.

The burner must flame evenly over the entire surface when operating correctly. The flame must burn with a clear, blue, stable flame. See the parts breakdown of the burner for the location of the view ports. The flame pattern should be as shown in the figures below.

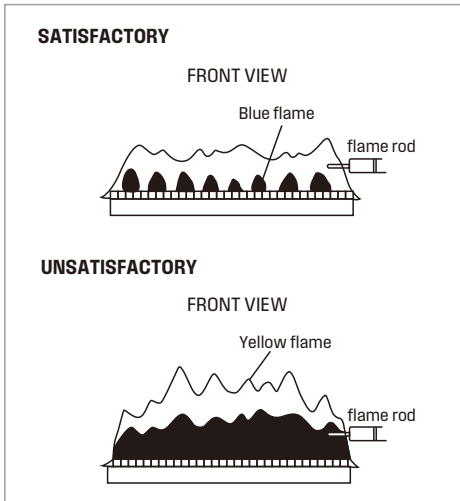

## 6.5 Pressure Relief Valve Maintenance



### WARNING

Testing the pressure relief valve should only be performed by a licensed professional. Water discharged from the pressure relief valve could cause severe burns instantly or death from scalds.



### WARNING

Before manually operating the pressure reducing valve, check that the hot water is discharged in a safe place. If water cannot escape from the end of the drain, turn off the air supply and turn off the power and call a qualified person to determine the cause. See the manufacturer of the pressure relief valve for inspection and maintenance requirements.



### WARNING

Do not check the safety valve when the water heater is in normal operation to avoid hot water burns.

- The dirt will directly affect the normal function of the safety valve function. It requires hot water system maintenance of anti-fouling and anti-scaling cleaning.
- The user must check the relief valve at least once a year. When checking, turn off the water heater's power supply and gas. Turn on the water inlet switch to create pressure in the water system. Then gently open relief valve handle until there is water out and then gently close, if there is no water out, indicating that the valve is invalid, this time should immediately turn off the water heater water switch and ask the service personnel to deal with. Before operating the handle, check the discharge line connecting the valve to ensure that the water drained from the valve can be drained to a suitable place.

\* This is a concept drawing only.

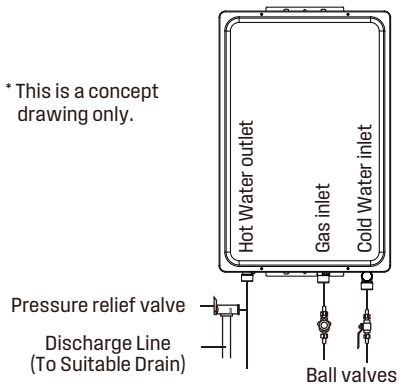

## 6.6 Freeze Prevention



### WARNING

If freezing conditions are expected, turn off water and gas and drain all water from the appliance. If power and the automatic frost protection are connected freezing will be prevented.

- Only the pipes and heat exchanger inside the water heater will be protected.
- Any hot or cold water pipes located outside of the unit will not be protected.
- Proper protection and insulation of these pipes will be required to ensure these are protected from freezing.

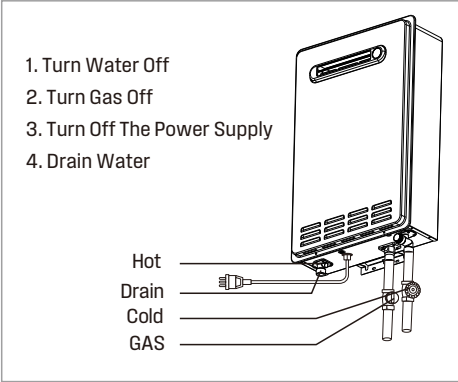

### Antifreeze Tips

- When the temperature is below 46.4 °F (8 °C) while above 37.4 °F (3 °C), keep your water heater staying plugged in a 120V 60HZ power supply, the anti-freeze system will automatically heat up to prevent the water heater from damages. No manual work is needed.
- If the machine is not used for a long time, or if the ambient temperature is below 32 °F (0 °C) and the machine cannot be kept powered with electricity and gas, it is necessary to drain the water from the water heater to prevent damage due to freezing. And here is the process:
  1. Turn off the gas shut-off valve.
  2. Power off the water heater and unplug the power supply to the machine.
  3. Turn off the water supply shut-off valve.
  4. Turn on hot water taps in the house, to release the water and pressure in the pipes.
  5. Screw out the drain screw on the hot water outlet.
  6. Remove the inlet water filter from the cold water inlet and it's valve by turning counterclockwise.
  7. Use a bucket to collect the residual water while draining. It may take more than 10 minutes to drain out the water thoroughly.

8. Securely screw the drain screw back in place; and screw the inlet water filter back in place.
9. Before you use the water heater next time, plug it into a 120 V 60 Hz power supply, and power on the water heater, and then open the water supply valve, hot water outlet valve, and the gas valve.



### CAUTION

- Please note damages caused by freezing are **NOT** covered under the tankless water heater warranty as an industry standard.
- Please make sure to take all the measures to protect your water heater.

## 6.7 Minimum Load Adjustment Method

Set the temperature on the controller to 35 °C and increase the inlet water temperature so that the outlet temperature is above 35 °C. It then proves that the water heater is operating at its minimum heat load.

## 6.8 Gas Pressure Test Position

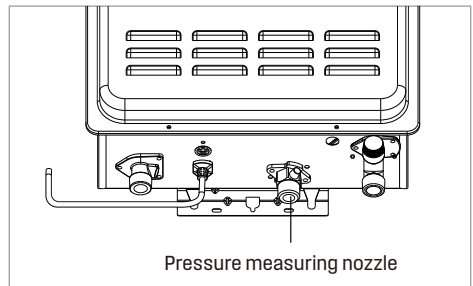

The gas inlet has a pressure measuring nozzle. The inlet gas pressure can be measured by unscrewing the screw.



### CAUTION

- Please close the gas valve before connecting the measuring instrument. Avoid accidents such as fires.