

3 Installation

3.1 Installation Instructions

1. Follow all local regulations, or in the absence of local regulations, follow the current version of the US National Gas Code: US ANSI Z 223. 1/NFPA 54 or Canada b 149. 1 natural gas, propane installation specifications.
2. All gas water heaters require proper and careful installation to ensure safe and efficient operation. This manual must be strictly observed.
3. The manifold pressure is preset at the factory. It is computer controlled and does not require adjustment.
4. Maintain proper maintenance space when installing equipment. So that it can be easily connected or removed.
5. The water heater must be installed in a place where it can be used at any time with a suitable amount of flammable air. The indoor water heater can be directly ventilated.
6. The electrical connection requires disconnecting the unit for maintenance and safety to turn off the power to the water heater.
7. Do not install the unit where the exhaust vents point to any openings in the building or where noise may disturb the neighbors. Ensure that the vent terminal meets the required distance from any door or opening by local regulations to prevent exhaust gases from entering the building.
8. Carefully select the installation location of the water heater, lint and fine powder Contaminants such as flour can block the air intake and reduce fan operation. This in turn, can lead to burning anomalies and shorten the life of the water heater. Regularly ensure that the area around the water heater the air inlet are free of dust, debris and other contaminants.
9. This water heater is for outdoor installation only.
 - Only install the water heater in a heated area where the temperature cannot be below freezing. The warranty does not cover damage caused by freezing.
 - The water heater must be securely mounted to a wall or other suitable structure.
 - The water heater cannot be installed on the floor.



WARNING

Water temperatures above 125 °F (52 °C) can cause severe burns or burns. The factory water temperature is set at 107 °F (42 °C) to minimize the risk of burns. Always check the water temperature before taking a shower or shower.

Do not store or use gasoline or other flammable materials, vapors or liquids near this equipment.

Do not connect to water or gas connections as this can damage the valve and can cause serious injury or death.

Do not use this product if it is immersed in water. Call a qualified installer or service facility immediately to replace the water-immersed water heater. Do not attempt to repair the unit. Must be replaced.

Do not disconnect the power supply if the ambient temperature is below freezing. The frost protection system is only effective when the device has power. **If the heat exchanger is damaged due to freezing, it is not covered by the warranty.**

Failure to follow these warnings can result in serious personal injury or death.

**WARNING**

- Installation and repair must be performed by a qualified installer (for example, a licensed plumber or gas fitter) or the warranty will be void.
- The installer (authorized professional) is responsible for properly installing the water heater and complying with all national, state/provincial and local regulations.
- The manufacturer does not recommend installing the water heater in a pit or location where gas and water may accumulate.
- Do not point the vent to any operating window, door or opening to the building.
- Do not install any air debris (such as a dryer) that could cause debris to get trapped in the combustion chamber unless the system is directly ventilated.
- Do not install the unit in water, debris or flammable vapors that may enter the flue terminal or intake line.
- Due to safety issues, the manufacturer does not recommend installing the water heater in the attic.

**WARNING**

- Make sure the equipment has adequate combustion air and proper ventilation. Failure to do so may result in carbon monoxide poisoning or death.
- Keep the area around the water heater clean. When the dust collects on the flame, the sensor will turn off the error code.
- Place the equipment for easy repair and maintenance.
- If a leak occurs, it is recommended to install a drain pan or other waterproof protection under the water heater.
- Failure to follow these warnings can result in serious personal injury, death and/or property damage.

**NOTICE**

- The warranty does not cover damage caused by water quality.
- This water heater can only use potable water. Do not introduce pool or hot spring water or any chemically treated water into the water heater.
- For all other types of applications, the water hardness level for single- family applications should not exceed 7 grains per gallon (120 ppm) or 4 grains (70 ppm) per gallon. The hardness of the water can cause scaling and can affect/damage the water heater. Hard scale must be avoided or controlled by proper water treatment.
- The pH of the water must be between 6.5 and 8.5.
- Well water must be disposed of.
- When the water heater is installed in a beauty salon, dry cleaner or in the air, there is such a chemical. Whenever any other location, the manufacturer recommends direct venting. Certain chemicals used in beauty salons or dry cleaners may affect the flame sensor. In this case underneath, the water heater may not work properly.
- Although the water heater is designed to operate with minimal sound, the manufacturer does not recommend installing the unit on a wall close to the bedroom or in a room for quiet study or meditation.
- Place the heater near the drain and the water will not damage the surrounding area. As with any water heating device, there is a real possibility of leakage at certain times during the life of the product. The manufacturer is not responsible for any water damage that may occur. If you install a drain pan under the unit, make sure it does not restrict the flow of combustion air.

3.2 Installation Checklist

- Unbox and check whether the water heater, installation manual and owner's guide, parts and accessories bag, are coming in the box.
- Check to ensure there are no corrosive chemicals in the air intake.
- Water supply should be free of chemicals, and water hardness that higher than allowed level may damage the water heater.
- Ensure there is enough space required for installation.
- Ensure there is enough distance required between the exhaust vent and air inlet of houses.
- Turn off hot water switch, turn on cold water switch and the drain screw, flush the debris and air out of the water pipes. Debris inside the water may damage the water heater. Please use buckets or extra water pipes if needed.
- Ensure no water leakages.
- Turn off cold and hot water switches before cleaning up water inlet filter. Put a bucket under the water heater's filter to catch any water out of the water heater. Screw out the water inlet filter, wash off debris and dusts, and then hand screw the filter back in. When it's done, turn on the cold and hot water switches.
- Ensure the pressure relieve valve's relieving capacity exceeds that of the water heater BTU input rating. Please refer to the specifications on the side of machine for BTU input ratings.
- Install a manual gas shut-off valve between the water heater and your gas supply line.
- Check to confirm there is no gas leakage in piping and fittings.
- Confirm the gas inlet pressure in the min-max range as required.
- Confirm you are using the gas type as required by the water heater.
- Confirm the power supply is 120 V/60 Hz, and properly grounded.
- Confirm the thermostat works normally.
- Connect a gas manometer to the pressure port to verify the system is working normally. Turn on appliances that use high flow rate hot water and set the water heater to its maximum operation capacity, the inlet gas pressure must be higher than the minimum pressure on the specification label.
- Do not induct poisonous chemicals into drinking water, like the chemicals used to process broiler water.
- Drain the water out of the water heater if you are not using the water heater for a significant time period.

3.3 Prepare for installation

Recommends that the following tools be used while installing the Water Heaters.

■ Parts included



Tankless
Water Heater



User Manual



Assembly Kit



Wired Controller

■ Tools needed (Not included)



Screw Driver



Pipe Wrench



Wrench

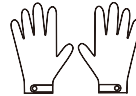

Gloves



Safety Glasses



Levelling
Instrument

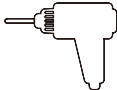

Hammer Drill
With Concrete Bits



Soapy Water



Gas Leak Detector

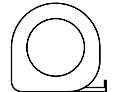

Ruler

■ Materials needed (Not included)



Teflon Tape



Pressure Relief Valve

■ Materials that may be needed (Not included)



NPT 3/4-in x 1/2-in dia
Threaded Male Adapter

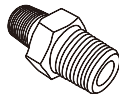

1/2" Hex Nipple

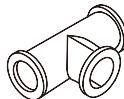

Threaded Tee Fitting
(Middle 3/4")

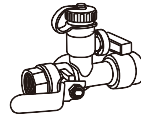

Hot Water
Isolation Valve

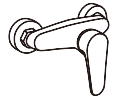

Thermostatic
Mixing Valve

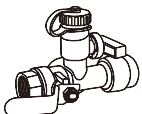

Cold Water
Isolation Valve



Single gang
electrical box



Electrical
Adhesive Tape



Pipe Wrap
Insulation

3.4 Determine Installation Location



WARNING

- DO NOT Install in areas where air for combustion can be contaminated with chemicals.
- Before installation, consider where air has the ability to travel within the building to the water heater.
- Make sure the equipment has adequate combustion air and proper ventilation. Failure to do so may result in carbon monoxide poisoning or death.
- Chemicals that are corrosive in nature should not be stored or used near the water heater.



WARNING

- Install the water heater as far away as possible from exhaust vent hoods.
- Install as far away as possible from air inlet vents. Corrosive fumes may be released through these vents when air is not being brought in through them.
- Chemicals that are corrosive in nature should not be stored or used near the water heater or vent termination.

You must ensure that clearances will be met and that the vent length will be within required limits. Consider the installation environment, water quality, and need for freeze protection. Requirements for the gas line, water lines, electrical connection, and condensate disposal can be found in their respective installation sections of this manual.

Water quality

Consideration of care for your water heater should include evaluation of water quality.

The water must be potable, free of corrosive chemicals, sand, dirt, or other contaminants. It is up to the installer to ensure the water does not contain corrosive chemicals, or elements that can affect or damage the heat exchanger. Water that contains chemicals exceeding the levels below affect and damage the heat exchanger. Replacement of the heat exchanger due to water quality damage is not covered by the warranty.

Environment

Air surrounding the water heater, venting, and vent termination(s) is used for combustion and must be free of any compounds that cause corrosion of internal components. These include corrosive compounds that are found in aerosol sprays, detergents, bleaches, cleaning solvents, oil based paints/ varnishes, and refrigerants. The air in beauty shops, dry cleaning stores, photo processing labs, and storage areas for pool supplies often contains these compounds.

IMPORTANT CONSIDERATIONS FOR:

Outdoor Water Heaters and Vent Terminations

- Install the water heater as far away as possible from exhaust vent hoods and dryer vents.
- Damage and repair due to corrosive compounds in the air are not covered by warranty.
- Install the water heater as far away as possible from any air inlet vents. Corrosive fumes, sometimes found in hair/ nail salons, spas, or other industries exposed to toxic fumes, may be released through these vents when not in operation.
- Chemicals that are corrosive in nature should not be stored or used near the water heater or vent termination. This re-quirement applies to internal (indoor) and external (outdoor) water heaters.

3.5 Installation Position



WARNING

Keep all the space around the water heater. Failure to do so may result in fire and may result in death, injury and or property loss.

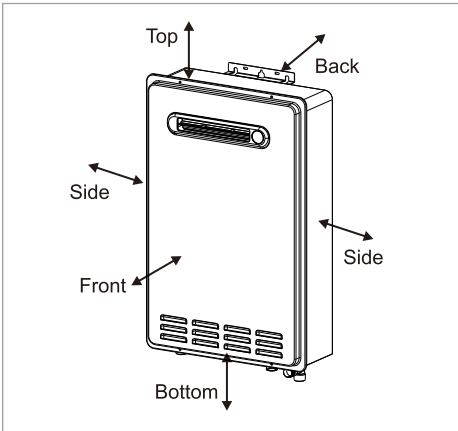

Minimum clearances from combustible or noncombustible construction and for servicing and proper operation:

Location	Clearances To Combustibles and Non-Combustibles
Top	2 in. (51 mm)
Bottom	12 in. (305 mm)
Front (Panel)	0 in. The clearance for servicing is 24 inches in front of the water heater. Do not block the combustion air openings.
Back	0 in. (0 mm)
Sides	2 in. (51 mm) 0.125 in. (3.18 mm) for recess box.
Front (Exhaust)	24 in. (610 mm)

Do not install this water heater under an overhang less than 3 ft. (91.4 cm) from its top. The area under the overhang must be open on three sides.

3.6 Other than Direct Vent (Outdoor): Termination Clearances

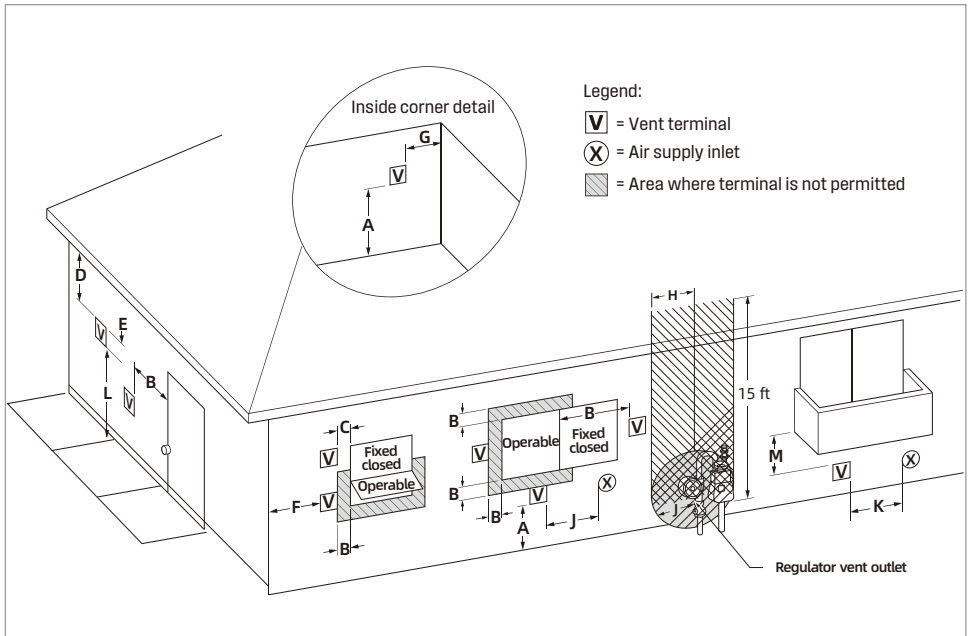

	Description	US installations ¹
A =	Clearance above grade, veranda, porch, deck, or balcony	12 in (30 cm)
B =	Clearance to window or door that may be opened	4 ft (1.2 m) below or to side of opening; 1 ft (300 mm) above opening
C =	Clearance to permanently closed window	*
D =	Vertical clearance to ventilated soffit located above the terminal within a horizontal distance of 2 ft (61 cm) from the center line of the terminal	*
E =	Clearance to unventilated soffit	*
F =	Clearance to outside corner	*
G =	Clearance to inside corner	*

	Description	US installations ¹
H =	Clearance to each side of center line extended above meter/ regulator assembly	.
I =	Clearance to service regulator vent outlet	.
J =	Clearance to nonmechanical air supply inlet to building or the combustion air inlet to any other appliance	4 ft (1.2 m) below or to side of opening; 1 ft (300 mm) above opening
K =	Clearance to a mechanical air supply inlet	3 ft (91 cm) above if within 10 ft (3 m) horizontally
L =	Clearance above paved sidewalk or paved driveway located on public property	Vents for Category II and IV appliances cannot be located above public walkways or other areas where condensate or vapor can cause a nuisance or hazard.
M =	Clearance under veranda, porch deck, or balcony	.

Notes: ¹In accordance with the current ANSI Z223.1/NFPA 54, National Fuel Gas Code

Clearance to opposite wall is 24 in. (60 cm).	
<p>[1] A vent shall not terminate directly above a sidewalk or paved driveway that is located between two single family dwellings and serves both dwellings.</p> <p>[2] Permitted only if veranda, porch, deck, or balcony is fully open on a minimum of two sides beneath the floor.</p>	<p>* Clearances are in accordance with local installation codes and the requirements of the gas supplier.</p>

If locally adopted installation codes specify clearances different than those illustrated, then the most stringent clearance shall prevail.

36 inches minimum from the top of the water heater to the overhang. The area under the overhang must be open on 3 sides

3.7 Termination Clearances for External (Outdoor) Water Heaters

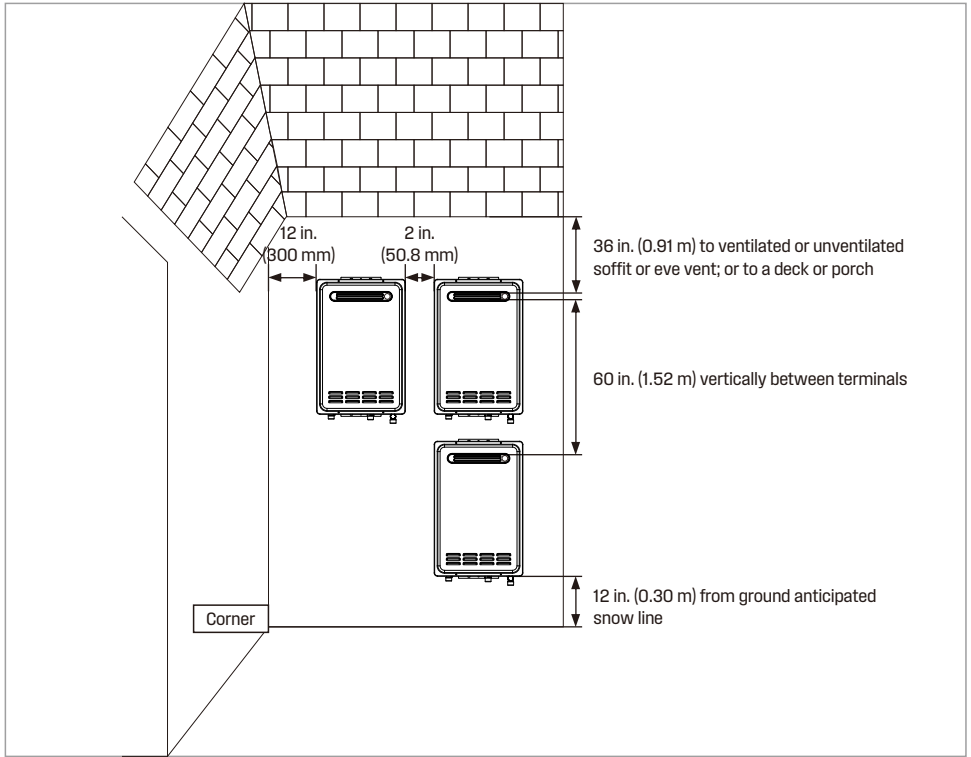

3.8 Mount to Wall

1. Identify the installation location and confirm that the installation will meet all required clearances.



NOTICE

The water heater must be installed in an upright position. Do not install upside down or on its side.

2. As shown on the below, first install the mounting hole on the wall. The upper mounting hole is fixed by the expansion screw, and the lower mounting hole is inserted into the plastic plug. Hang the water heater, place the washer and nut on top, and tighten the nut. Screw on the wooden below.

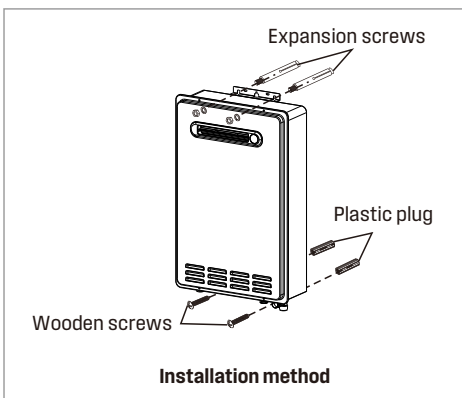

3.9 Gas And Gas Pipe Specifications



WARNING

- First check that the gas type matches the nameplate.
- Make sure that all gas regulators in use are operating properly and provide gas pressure within the specified range as shown below. Excessive intake pressure can cause serious accidents.
- Failure to follow these warnings can result in serious personal injury, carbon monoxide poisoning or death.

- Maximum and minimum gas pressure:

Gas type	Intake pressure
Natural Gas	Min. 3.5" W.C. (0.87kPa) Max. 10.5" W.C. (2.61kPa)
Propane	Min. 8.0" W.C. (1.99kPa) Max. 13.0" W.C. (3.23kPa)

- Inlet gas pressures outside the above range of values may adversely affect the performance of the water heater. These pressures are measured when the water heater is fully operational.
- The intake pressure must not exceed the above maximum values; gas pressures outside the specified range will result in hazardous operating conditions and equipment damage.
- Be sure to disconnect the gas line from the water heater before the main gas supply pressure test is completed to avoid damaging the water heater.
- If the heater's supply pressure is greater than the specified maximum, a pressure regulator is required. The regulator must reduce the gas pressure to within acceptable limits.
- Install the gas regulator according to the manufacturer's instructions.
- The regulator must be sized for the water heater input and provided with the specified pressure listed on the nameplate.
- It is recommended that there be at least 3 ft (1 m) of tubing between the regulator outlet and the water inlet gas connection in the absence of a minimum installation distance.

3.10 Gas Connection



WARNING

1. A licensed professional must install the gas supply.
2. Turn off 120v power supply.
3. Turn off the gas.
4. Gas is flammable. Do not smoke or provide other ignition sources while working with gas.
5. Do not turn on the water heater or gas until all fumes are gone.

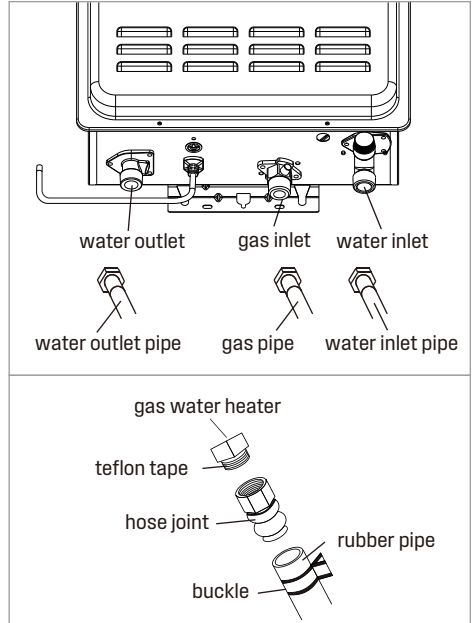

NOTICE

Use sealant tape or other approved sealing method on the threads for a secure, no water or gas leakage.

1. Install a manual gas shut-off valve between the water heater and the air supply line.
2. When the gas connection is completed, the gas leak test must be performed by applying soapy water to all gas fittings and observing the air bubbles or using a gas leak detection device.
 - During any system stress test where the test pressure exceeds 1/2 psi (3.5 KPa), it must be the water heater and its separate shut-off valve are disconnected from the air supply piping system.
 - During pressure testing of any gas supply piping system with a test pressure equal to or less than 1/2 psi (3.5 KPa), the water heater must be isolated from the air supply piping system by closing its separate manual shut-off valve.
3. Always remove any debris and/or water gas lines before connecting to the air intake.



NOTICE

Do not use this product if any parts are underwater. Contact the installer or service agency immediately to replace the flooded water heater. Do not try to repair the heater. Replacement must be done!

3.11 Water Connection



WARNING

Do not use this product if any parts are underwater. Contact the installer or service agency immediately to replace the flooded water heater. Do not try to repair the heater. Replacement must be done!



NOTICE

Do not reverse the hot and cold inlet connections of the water heater. If connected in reverse, the water heater will not start properly.

1. All piping, fittings, valves and other components, including welding materials, must be suitable for potable water systems.
2. The on/off valve must be installed in the cold water inlet of the water heater between the main water supply line and the water heater.
3. Flush the water line to remove any debris before installing the water heater.
4. There is a wire mesh filter in the cold water inlet for filtering debris into the heater. This requires regular cleaning to maintain optimal flow.

3.12 Pressure Relief Valve

The water heater has a built-in high temperature disconnect switch as a standard safety function (called a Hi-limit switch), so a "pressure only" safety valve is required.

- The unit is not equipped with an approved pressure reducing valve.
- An approved pressure relief valve must be installed at the hot water outlet.
- The pressure relief valve must comply with ANSI Z 21.22 • CSA 4.4. Installation must comply with local regulations.
- The pressure relief valve must be rated up to 150 psi and to at least the maximum Btu/hr of the appliance.
- The drain line of the pressure reducing valve must be guided so that hot water does not splash out and cause damage or personal injury.
- Connect the drain hose to the pressure relief valve so that the end of the tube is 6 inches (152 mm) from the floor. The tube must be completely drained without any bends or blockages.
- If the pressure relief valve is periodically discharged, this may be due to thermal expansion.
- In the closed water supply system. Please contact your water supplier or local plumbing professional to find out how to correct this situation. Do not block the pressure relief valve.
- The pressure relief valve must be manually operated periodically to check that it is operating correctly. Before manually operating the valve, check that the pressure relief valve is vented in a safe place.
- Do not place a valve between the safety valve and the water heater.

3.13 Electrical Connections



WARNING

- Comply with the electrical code requirements of local authorities with jurisdiction. If there is no such requirement, please follow the current version of the National Electrical Code ANSI/NFPA 70 or the current Canadian version of CSA C22.1 Canadian Electrical Code Part 1.
- When repairing or replacing parts in the water heater, mark all wires before Disconnect to make it easy to reconnect. Incorrect wiring can result in incorrect and dangerous operation. Confirm correct operation after repair.
- Failure to follow these warnings can result in personal injury or death.

1. The water heater must be grounded. Do not connect the ground wire to a gas or water pipe.
2. The water heater requires a 120 VAC, 60 Hz power supply and is properly grounded.
 - For maintenance reasons, appropriate disconnects (i.e. on/off switches, power plugs, etc.) must be provided to control the main power supply to the water heater. (Must comply with local regulations.)
 - Connect the power supply to the water heater exactly as shown in the wiring diagram.
3. The plug of the water heater is not plugged into the standard American three-pin plug, and the socket must be properly grounded.
4. A surge protector is recommended to protect the equipment from power surges.

3.14 Wired Controller

- The water heater can be installed with up to three wired controllers. Each wired controller has two functions which can adjust the set temperature and indicate the error code.
- **PRIORITY function:** The controller that is activated first (i.e. button is pressed) is given PRIORITY function, and can freely adjust the temperature. Remaining controllers will display the set temperature however will not be able to make any adjustments. After a 15 minute period of inactivity the priority on the first remote will cease and priority can then be assigned to another remote by activating it (i.e. a button is pressed). Then the new controller has priority and the cycle repeats.
- **Default setting temperature:** At the initial power on, the setting temperature will be the same as the value set on DIP switch. After the initial use, it will remember the former setting temperature.
- All water heater models have self diagnostic function for safety and convenience when troubleshooting. If there is a problem with the installation or the unit, it will display a numerical error code on the wired controller (or the LED of the computer board will be blink.)

Wired controller installation requirements

- The wired controllers are splash resistant, however should not be positioned where it can be splashed directly & should be appropriately sealed between the surface of the wall & controller.
- The wired controller can be installed in the bathroom provided it is correctly installed.

3.14.1 Wired Controller Installation

Choose a convenient location to place the wired controller base. The connection between the wire controller and the water heater should be reasonably arranged according to the specific environment. Fix the bottom controller holder with the two screws ST4x16 mm provided and place the controller into the bracket.

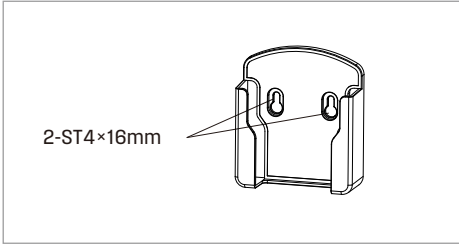

3.14.2 Connection of Wired Controller Wiring to the Water Heater

1. Turn off the power supply to the water heater.
2. Connect the first controller only and turn on the power supply to the water heater.
3. Turn off the first controller by pressing the "⏻" button (LED light will turn off).
4. Continue to connect any additional wired control wires to the remote terminals directly.
5. DO NOT jump or short-circuit wires otherwise the PCB may become damaged.
6. Return the front cover.

DO NOT turn on the remote until instructed.
7. Activate the first remote by pressing & holding the "—" button for 5 seconds until a single beep sounds. Then press & hold the "+" button for 5 seconds until the LED screen lights up.
8. Adjust the on screen value to set the ID (available ID's include -0, -1, -2). Press the "⏻" button to confirm (The ID of the wired control cannot be repeated).
9. Repeat for all additional controllers.
10. Controllers can now be turned on and will operate as per the PRIORITY function (refer to 5.4 How to Set the Temperature).

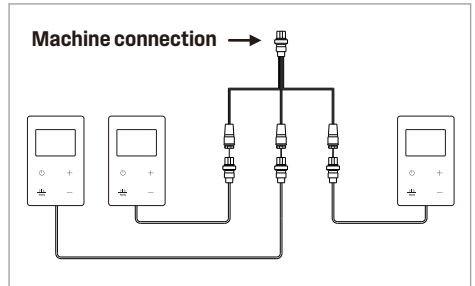

3.15 Initial Test Run



WARNING

For your safety, please read before operation.

- Check for leaks in the gas and water connections for the first time before the ignition.
- Open the main gas supply valve of the unit by hand only to avoid any sparks. Never use tools. If the knob does not turn by hand, do not attempt to force rotation; call a qualified service technician. Forced repairs may result in a fire or explosion due to a gas leak.
- Always check for leaks at the bottom of the unit, as some gases are heavier than air and may settle toward the floor.
- Check gas pressure. See "6.8 Gas pressure test position".
- Do not attempt to manually ignite the burner. It is equipped with an electronic ignition device that automatically ignites the burner.
- Check that the water heater is ventilated and that the flammable air is normal.
- Do not use this product if it is in contact with water or immersed in water. Contact a qualified installer or service facility immediately to replace the water heater. Do not attempt to repair the device! Must be replaced!



WARNING

If you smell gas:

- Do not attempt to start the water heater.
- Do not touch any electric switch.
- Do not use any mobile phones in your building. Call your gas supplier immediately from your neighbor's phone. Follow the instructions of the gas supplier.
- If you are unable to contact your gas supplier, please call the fire department.
- Failure to follow these warnings can result in fire or explosion, resulting in serious injury or death.

The user confirms that the water heater is installed correctly before the initial use, and carefully checks whether the connection is correct and there is no leakage. After confirming, please follow the steps below:

Initial Test Run		
1	Turn on the water heater's 120v, 60 Hz power supply.	
2	Remove debris from the inlet screen.	
3	Open the valve on the inlet water.	
4	Turn on the hot water tap, make sure there is water flowing out, then turn off the hot water tap.	
5	Open the manual gas valve.	
6	Press the switch button on the controller and set the desired hot water temperature.	
7	When you turn on the hot water tap, you can enjoy the constant flow of hot water.	