



User Manual

Outdoor Tankless Water Heater

Products:

HS120



CSA/ANSI Z21.10.3:19-CSA4.3:19

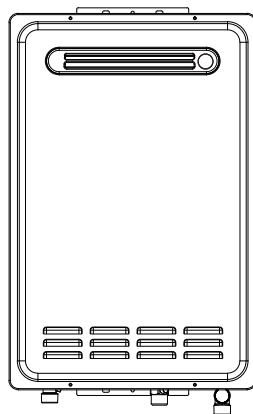

WARNING

If the information in these instructions is not followed exactly, a fire or explosion may result causing property damage, personal injury or death.

- Do not store or use gasoline or other flammable vapors and liquids in the vicinity of this or any other appliance.
- **WHAT TO DO IF YOU SMELL GAS**
 - Do not try to light any appliance.
 - Do not touch any electrical switch; do not use any phone in your building.
 - Immediately call your gas supplier from a neighbor's phone. Follow the gas supplier's instructions.
 - If you cannot reach your gas supplier, call the fire department.
- Installation and service must be performed by a licensed professional.

**WARNING**

If the information in these instructions is not followed exactly, a fire or explosion may result causing property damage, personal injury or death.

- Do not store or use gasoline or other flammable vapors and liquids in the vicinity of this or any other appliance.
- **WHAT TO DO IF YOU SMELL GAS**
- Do not try to light any appliance.
- Do not touch any electrical switch; do not use any phone in your building.
- Immediately call your gas supplier from a neighbor's phone. Follow the gas supplier's Installation.
- If you cannot reach your gas supplier, call the fire department.
- Installation and service must be performed by a qualified installer, service agency or the gas supplier.

Please read these instructions carefully and follow all instructions, guidelines, and warnings included in this product manual in order to ensure that you install, use, and maintain the product properly at all times. These instructions **MUST** stay with this product. By using the product, you hereby confirm that you have read all instructions, guidelines, and warnings carefully and that you understand and agree to abide by the terms and conditions as set forth herein. You agree to use this product only for the intended purpose and application and in accordance with the instructions, guidelines, and warnings as set forth in this product manual as well as in accordance with all applicable laws and regulations. A failure to read and follow the instructions and warnings set forth herein may result in an injury to yourself and others, damage to your product, or damage to other property in the vicinity. This product manual, including the instructions, guidelines, warnings, and related documentation, may be subject to changes and updates.

CONTENTS

1 Safety Information	04
1.1 Safety Definitions	04
1.2 Safety Warnings and Operation Safety Guidelines	04
2 General Information	06
2.1 Function Introduction and Explanation	06
2.2 Dimensions and Connection Points	07
2.3 Model and Specification	08
2.4 Component Diagram	09
3 Installation	10
3.1 Installation Instructions	10
3.2 Installation Checklist	12
3.3 Prepare for installation	13
3.4 Determine Installation Location	14
3.5 Installation Position	15
3.6 Other than Direct Vent (Outdoor): Termination Clearances	16
3.7 Termination Clearances for External (Outdoor) Water Heaters	18
3.8 Mount to Wall	19
3.9 Gas And Gas Pipe Specifications	19
3.10 Gas Connection	20
3.11 Water Connection	21
3.12 Pressure Relief Valve	21
3.13 Electrical Connections	22
3.14 Wired Controller	22
3.15 Initial Test Run	24
4 Operation	25
4.1 Safe Operation	25
4.2 Wired Controller	27
5 Troubleshooting	29
6 Maintenance	32
6.1 Vent System	32
6.2 Unit Draining and Filter Cleaning	32
6.3 Clean Burners	32
6.4 Visual Inspection of Flame	33
6.5 Pressure Relief Valve Maintenance	33
6.6 Freeze Prevention	33
6.7 Minimum Load Adjustment Method	34
6.8 Gas Pressure Test Position	34
7 Wiring Diagram	35
8 Packing List	36
French	37

1 Safety Information

1.1 Safety Definitions

This manual has safety information and instructions to help you eliminate or reduce the risk of accidents and injuries.



DANGER

Indicates an imminently hazardous situation which, if not avoided, will result in death or serious injury.



WARNING

Indicates a hazardous situation that, if not avoided, could result in death or serious injury.



CAUTION

Indicates a hazardous situation which, if not avoided, could result in property damage and minor or moderate injury.



NOTICE

This symbol indicates important information where there is no risk to people or property.

1.2 Safety Warnings and Operation Safety Guidelines

1. Follow all local regulations, or in the absence of local regulations, follow the current version of the US National Gas Code: US ANSI Z223.1/NFPA 54, and/or CSA B149.1, Natural Gas and Propane Installation Code.
2. Ground the equipment properly in accordance with all local regulations or without local regulations, using the National Electrical Code: ANSI/NFPA 70 or Canadian CSA standard C 22.1 Canadian Electrical Code Part 1.
3. Carefully plan where you plan to install the water heater. Please ensure: Your water heater will have enough flammable air and proper ventilation. Install the water heater in a location where water leaks do

not damage the surrounding area. (See "3.1 Installation Instructions")

4. Check the gas type, gas pressure, water pressure and rated current on the nameplate.
If the unit does not meet your requirements, please do not install and consult the manufacturer.
5. If any problems occur, turn off all hot water taps and turn off the gas. Then call a trained technician or gas company or manufacturer.



WARNING

- Use only your hand to push in or turn the gas control knob. Never use tools. If the knob will not push in or turn by hand, do not try to repair it; call a licensed professional. Force or attempted repair may result in a fire or explosion.
- Do not use this appliance if any part has been under water. Immediately call a licensed professional to inspect the appliance and to replace any part of the control system and any gas control which has been under water.
- Do not use substitute materials. Use only parts certified for the appliance.
- Should overheating occur or the gas supply fail to shut off, turn off the manual gas control valve to the appliance.
- Do not use an extension cord or an adapter plug with this appliance.
- Any alteration to the appliance or its controls can be dangerous and will void the warranty.
- Proper venting is required for the safe operation of this appliance.
- Ensure appliance venting is not blocked or partially blocked.
- Ensure that in cases of freezing weather the water heater and its water lines are protected to prevent freezing.

**WARNING**

- Before operating, smell all around the appliance area for gas. Be sure to smell next to the floor because some gas is heavier than air and will settle on the floor.
- Keep the area around the appliance clear and free from combustible materials, gasoline, and other flammable vapors and liquids.
- Combustible construction refers to adjacent walls and ceiling and should not be confused with combustible or flammable products and materials.
- Combustible and/or flammable products and materials should never be stored in the vicinity of this or any gas appliance.
- Always check the water temperature before entering a shower or bath.
- To protect yourself from harm, before performing maintenance:
 1. Turn off the electrical power supply by unplugging the power cord or by turning off the electricity at the circuit breaker. (The temperature controller does not control the electrical power.)
 2. Turn off the gas at the manual gas valve, usually located immediately below the water heater.
 3. Turn off the incoming water supply. This can be done at the isolation valve immediately below the water heater or by turning off the water supply to the building.

**WARNING**

This product can expose you to lead, which is known to the state of California to cause cancer and birth defects or other reproductive harm. For more information, go to www.P65warnings.ca.gov.

**CAUTION**

- **BURN HAZARD.** Hot exhaust and vent may cause serious burns. Keep away from the water heater unit. Keep small children and animals away from the unit.
- Hot water outlet pipes leaving the unit can be hot to touch. In residential applications, insulation must be used for hot water pipes below 36" due to burn risk to children.

2 General Information

2.1 Function Introduction and Explanation

- The unit is a box less gas fast water heater designed to effectively supply hot water continuously during proper installation.
- Read all installation instructions thoroughly before installing this product.
- If you have any questions or concerns about this device, please consult the manufacturer or its local agent.
- This water heater can only be installed outdoors for outdoor models.
- The model description is listed on the nameplate, which is located on the side panel of the water heater.

The principle of the water heater is shown below:

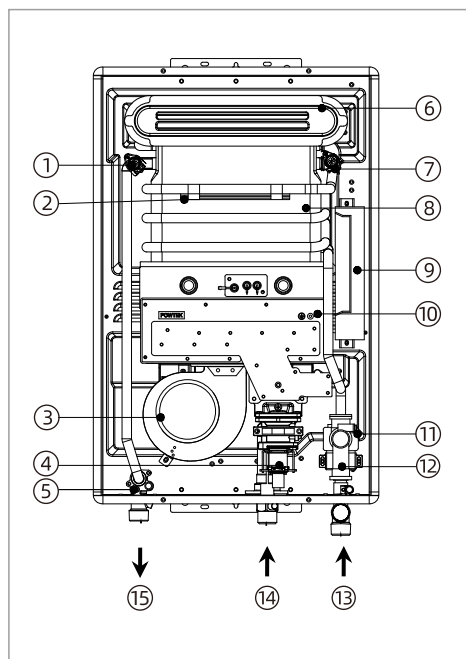

- ① High Limit Switch (Overheat Protection)
- ② Freeze Protection Heating Element
- ③ Fan Motor Assembly
- ④ Gas Proportional Valve
- ⑤ Outlet Water Temperature Sensor
- ⑥ Exhaust Outlet
- ⑦ Freeze Protection Thermostat
- ⑧ Primary Heat Exchanger
- ⑨ Printed Circuit Board (PCB)
- ⑩ Burner Assembly
- ⑪ Inlet Water Temperature Sensor
- ⑫ Flow Sensor / Water Control Valve Assembly
- ⑬ Cold Water Inlet Connection
- ⑭ Gas Intake Connection
- ⑮ Hot Water Outlet Connection

This series of gas water heaters with solar linkage function by default:

- a. When it is detected that the inlet water temperature reaches a predetermined value, the water heater does not start;
- b. When the combustion work is started, and the inlet water temperature is less than the set temperature by 4 °F (2 °C), the water heater stops working;
- c. When the combustion work is started, if the inlet water temperature is ≥ 140 °F (60 °C), the water heater stops working.

Controller temperature adjustment range		95~158 °F (35 °C~70 °C)
System start condition	Inlet water temperature	< 113 °F (45 °C)
	Set temperature- inlet water temperature	< 39 °F (4 °C)
Normal combustion conditions	Inlet water temperature	< 140 °F (60 °C)
	Set temperature- inlet water temperature	< 35 °F (2 °C)

2.2 Dimensions and Connection Points



NOTICE

The images used in this document are for reference purposes only. Components and component locations may vary according to specific product models. Measurements may vary ± 0.38 in. (10 mm).

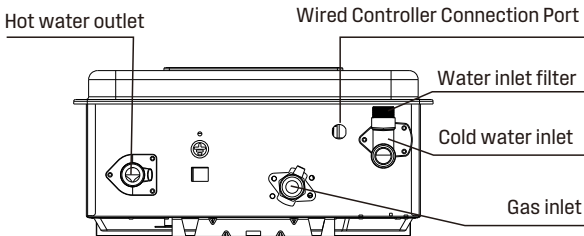
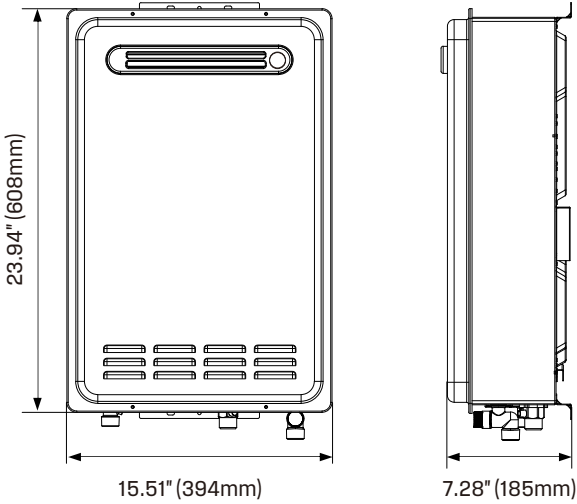

2.3 Model and Specification

MODEL		HS120	
Gas Category		NATURAL GAS	PROPANE
Minimum Gas Consumption Btu/h		16,500	
Maximum Gas Consumption Btu/h		120,000	
Hot Water Capacity (Min - Max) *		0.53 - 4.23 GPM (2 - 16 L/min)	
Temperature Setting (no controller)		95-158 °F (35-70°C)	
Maximum Temp Setting		158 °F (70 °C)	
Minimum Temperature Setting		95 °F (35 °C)	
Electrical Data	Normal	33 W	38 W
	Standby	2 W	
	Anti-frost Protection	100 W	
	Fuse	10 A	
Gas Supply Pressure		3.5 - 10.5 inch W.C.	8.0 - 13.5 inch W.C.
By-Pass Control		Fixed	
Type of Appliance		Tankless, Temperature controlled continuous flow gas hot water system	
Connections		Gas Supply: 3/4" MNPT Cold Water Inlet: 3/4" MNPT Hot Water Outlet: 3/4" MNPT	
Ignition System		Direct Electronic Ignition	
Electric Connections		AC 120 Volts, 60Hz	
Water Temperature Control		Simulation Feed forward and Feedback	
Water Supply Pressure		Minimum Water Pressure: 15 PSI (Recommended 30-50 PSI for maximum performance)	
Maximum Water Supply Pressure		150 PSI	

* Minimum flow may vary slightly depending on the temperature setting and the inlet water temperature. Minimum activation flow is 0.53 GPM (2 L/min).

2.4 Component Diagram

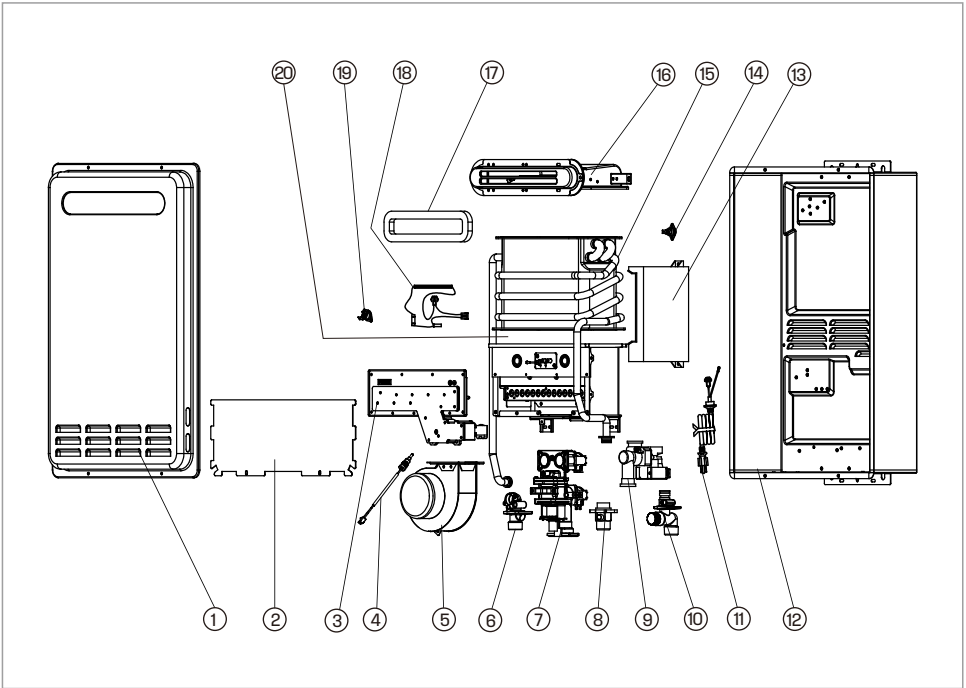

- | | |
|--|---|
| ① Front Cover Panel | ⑪ Power Supply Cord |
| ② Water Deflector | ⑫ Rear Panel |
| ③ Gas Manifold | ⑬ Printed Circuit Board (PCB) |
| ④ Outlet Water Temperature Sensor | ⑭ Freeze Protection Thermostat |
| ⑤ Fan Motor Assembly | ⑮ Primary Heat Exchanger |
| ⑥ Hot Water Outlet Connection | ⑯ Exhaust Outlet |
| ⑦ Gas Proportional Valve | ⑰ Sealing Insulation |
| ⑧ Gas Intake Connection | ⑱ Freeze Protection Heating Element |
| ⑨ Flow Sensor / Water Control Valve Assembly | ⑲ High Limit Switch (Overheat Protection) |
| ⑩ Cold Water Inlet Connection | ⑳ Burner Assembly |

3 Installation

3.1 Installation Instructions

1. Follow all local regulations, or in the absence of local regulations, follow the current version of the US National Gas Code: US ANSI Z 223. 1/NFPA 54 or Canada b 149. 1 natural gas, propane installation specifications.
2. All gas water heaters require proper and careful installation to ensure safe and efficient operation. This manual must be strictly observed.
3. The manifold pressure is preset at the factory. It is computer controlled and does not require adjustment.
4. Maintain proper maintenance space when installing equipment. So that it can be easily connected or removed.
5. The water heater must be installed in a place where it can be used at any time with a suitable amount of flammable air. The indoor water heater can be directly ventilated.
6. The electrical connection requires disconnecting the unit for maintenance and safety to turn off the power to the water heater.
7. Do not install the unit where the exhaust vents point to any openings in the building or where noise may disturb the neighbors. Ensure that the vent terminal meets the required distance from any door or opening by local regulations to prevent exhaust gases from entering the building.
8. Carefully select the installation location of the water heater, lint and fine powder Contaminants such as flour can block the air intake and reduce fan operation. This in turn, can lead to burning anomalies and shorten the life of the water heater. Regularly ensure that the area around the water heater the air inlet are free of dust, debris and other contaminants.
9. This water heater is for outdoor installation only.
 - Only install the water heater in a heated area where the temperature cannot be below freezing. The warranty does not cover damage caused by freezing.
 - The water heater must be securely mounted to a wall or other suitable structure.
 - The water heater cannot be installed on the floor.



WARNING

Water temperatures above 125 °F (52 °C) can cause severe burns or burns. The factory water temperature is set at 107 °F (42 °C) to minimize the risk of burns. Always check the water temperature before taking a shower or shower.

Do not store or use gasoline or other flammable materials, vapors or liquids near this equipment.

Do not connect to water or gas connections as this can damage the valve and can cause serious injury or death.

Do not use this product if it is immersed in water. Call a qualified installer or service facility immediately to replace the water-immersed water heater. Do not attempt to repair the unit. Must be replaced.

Do not disconnect the power supply if the ambient temperature is below freezing. The frost protection system is only effective when the device has power. **If the heat exchanger is damaged due to freezing, it is not covered by the warranty.**

Failure to follow these warnings can result in serious personal injury or death.

**WARNING**

- Installation and repair must be performed by a qualified installer (for example, a licensed plumber or gas fitter) or the warranty will be void.
- The installer (authorized professional) is responsible for properly installing the water heater and complying with all national, state/provincial and local regulations.
- The manufacturer does not recommend installing the water heater in a pit or location where gas and water may accumulate.
- Do not point the vent to any operating window, door or opening to the building.
- Do not install any air debris (such as a dryer) that could cause debris to get trapped in the combustion chamber unless the system is directly ventilated.
- Do not install the unit in water, debris or flammable vapors that may enter the flue terminal or intake line.
- Due to safety issues, the manufacturer does not recommend installing the water heater in the attic.

**WARNING**

- Make sure the equipment has adequate combustion air and proper ventilation. Failure to do so may result in carbon monoxide poisoning or death.
- Keep the area around the water heater clean. When the dust collects on the flame, the sensor will turn off the error code.
- Place the equipment for easy repair and maintenance.
- If a leak occurs, it is recommended to install a drain pan or other waterproof protection under the water heater.
- Failure to follow these warnings can result in serious personal injury, death and/or property damage.

**NOTICE**

- The warranty does not cover damage caused by water quality.
- This water heater can only use potable water. Do not introduce pool or hot spring water or any chemically treated water into the water heater.
- For all other types of applications, the water hardness level for single- family applications should not exceed 7 grains per gallon (120 ppm) or 4 grains (70 ppm) per gallon. The hardness of the water can cause scaling and can affect/damage the water heater. Hard scale must be avoided or controlled by proper water treatment.
- The pH of the water must be between 6.5 and 8.5.
- Well water must be disposed of.
- When the water heater is installed in a beauty salon, dry cleaner or in the air, there is such a chemical. Whenever any other location, the manufacturer recommends direct venting. Certain chemicals used in beauty salons or dry cleaners may affect the flame sensor. In this case underneath, the water heater may not work properly.
- Although the water heater is designed to operate with minimal sound, the manufacturer does not recommend installing the unit on a wall close to the bedroom or in a room for quiet study or meditation.
- Place the heater near the drain and the water will not damage the surrounding area. As with any water heating device, there is a real possibility of leakage at certain times during the life of the product. The manufacturer is not responsible for any water damage that may occur. If you install a drain pan under the unit, make sure it does not restrict the flow of combustion air.

3.2 Installation Checklist

- Unbox and check whether the water heater, installation manual and owner's guide, parts and accessories bag, are coming in the box.
- Check to ensure there are no corrosive chemicals in the air intake.
- Water supply should be free of chemicals, and water hardness that higher than allowed level may damage the water heater.
- Ensure there is enough space required for installation.
- Ensure there is enough distance required between the exhaust vent and air inlet of houses.
- Turn off hot water switch, turn on cold water switch and the drain screw, flush the debris and air out of the water pipes. Debris inside the water may damage the water heater. Please use buckets or extra water pipes if needed.
- Ensure no water leakages.
- Turn off cold and hot water switches before cleaning up water inlet filter. Put a bucket under the water heater's filter to catch any water out of the water heater. Screw out the water inlet filter, wash off debris and dusts, and then hand screw the filter back in. When it's done, turn on the cold and hot water switches.
- Ensure the pressure relieve valve's relieving capacity exceeds that of the water heater BTU input rating. Please refer to the specifications on the side of machine for BTU input ratings.
- Install a manual gas shut-off valve between the water heater and your gas supply line.
- Check to confirm there is no gas leakage in piping and fittings.
- Confirm the gas inlet pressure in the min-max range as required.
- Confirm you are using the gas type as required by the water heater.
- Confirm the power supply is 120 V/60 Hz, and properly grounded.
- Confirm the thermostat works normally.
- Connect a gas manometer to the pressure port to verify the system is working normally. Turn on appliances that use high flow rate hot water and set the water heater to its maximum operation capacity, the inlet gas pressure must be higher than the minimum pressure on the specification label.
- Do not induct poisonous chemicals into drinking water, like the chemicals used to process broiler water.
- Drain the water out of the water heater if you are not using the water heater for a significant time period.

3.3 Prepare for installation

Recommends that the following tools be used while installing the Water Heaters.

■ Parts included



Tankless
Water Heater



User Manual



Assembly Kit



Wired Controller

■ Tools needed (Not included)



Screw Driver



Pipe Wrench



Wrench

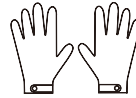

Gloves



Safety Glasses



Levelling
Instrument

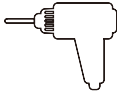

Hammer Drill
With Concrete Bits



Soapy Water



Gas Leak Detector

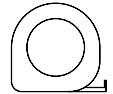

Ruler

■ Materials needed (Not included)



Teflon Tape



Pressure Relief Valve

■ Materials that may be needed (Not included)



NPT 3/4-in x 1/2-in dia
Threaded Male Adapter

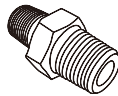

1/2" Hex Nipple

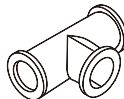

Threaded Tee Fitting
(Middle 3/4")

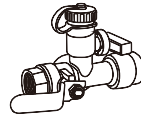

Hot Water
Isolation Valve

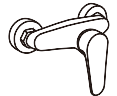

Thermostatic
Mixing Valve

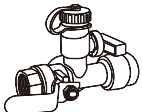

Cold Water
Isolation Valve



Single gang
electrical box



Electrical
Adhesive Tape



Pipe Wrap
Insulation

3.4 Determine Installation Location



WARNING

- DO NOT Install in areas where air for combustion can be contaminated with chemicals.
- Before installation, consider where air has the ability to travel within the building to the water heater.
- Make sure the equipment has adequate combustion air and proper ventilation. Failure to do so may result in carbon monoxide poisoning or death.
- Chemicals that are corrosive in nature should not be stored or used near the water heater.



WARNING

- Install the water heater as far away as possible from exhaust vent hoods.
- Install as far away as possible from air inlet vents. Corrosive fumes may be released through these vents when air is not being brought in through them.
- Chemicals that are corrosive in nature should not be stored or used near the water heater or vent termination.

You must ensure that clearances will be met and that the vent length will be within required limits. Consider the installation environment, water quality, and need for freeze protection. Requirements for the gas line, water lines, electrical connection, and condensate disposal can be found in their respective installation sections of this manual.

Water quality

Consideration of care for your water heater should include evaluation of water quality.

The water must be potable, free of corrosive chemicals, sand, dirt, or other contaminants. It is up to the installer to ensure the water does not contain corrosive chemicals, or elements that can affect or damage the heat exchanger. Water that contains chemicals exceeding the levels below affect and damage the heat exchanger. Replacement of the heat exchanger due to water quality damage is not covered by the warranty.

Environment

Air surrounding the water heater, venting, and vent termination(s) is used for combustion and must be free of any compounds that cause corrosion of internal components. These include corrosive compounds that are found in aerosol sprays, detergents, bleaches, cleaning solvents, oil based paints/ varnishes, and refrigerants. The air in beauty shops, dry cleaning stores, photo processing labs, and storage areas for pool supplies often contains these compounds.

IMPORTANT CONSIDERATIONS FOR:

Outdoor Water Heaters and Vent Terminations

- Install the water heater as far away as possible from exhaust vent hoods and dryer vents.
- Damage and repair due to corrosive compounds in the air are not covered by warranty.
- Install the water heater as far away as possible from any air inlet vents. Corrosive fumes, sometimes found in hair/ nail salons, spas, or other industries exposed to toxic fumes, may be released through these vents when not in operation.
- Chemicals that are corrosive in nature should not be stored or used near the water heater or vent termination. This re-quirement applies to internal (indoor) and external (outdoor) water heaters.

3.5 Installation Position



WARNING

Keep all the space around the water heater. Failure to do so may result in fire and may result in death, injury and or property loss.

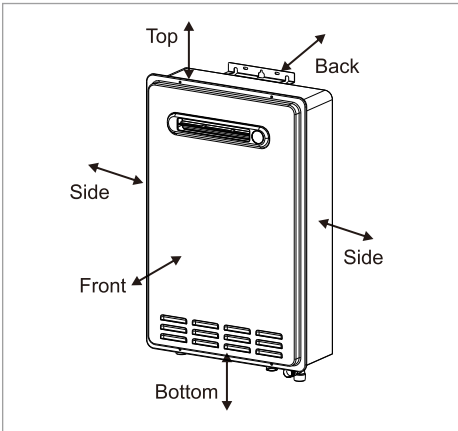

Minimum clearances from combustible or noncombustible construction and for servicing and proper operation:

Location	Clearances To Combustibles and Non-Combustibles
Top	2 in. (51 mm)
Bottom	12 in. (305 mm)
Front (Panel)	0 in. The clearance for servicing is 24 inches in front of the water heater. Do not block the combustion air openings.
Back	0 in. (0 mm)
Sides	2 in. (51 mm) 0.125 in. (3.18 mm) for recess box.
Front (Exhaust)	24 in. (610 mm)

Do not install this water heater under an overhang less than 3 ft. (91.4 cm) from its top. The area under the overhang must be open on three sides.

3.6 Other than Direct Vent (Outdoor): Termination Clearances

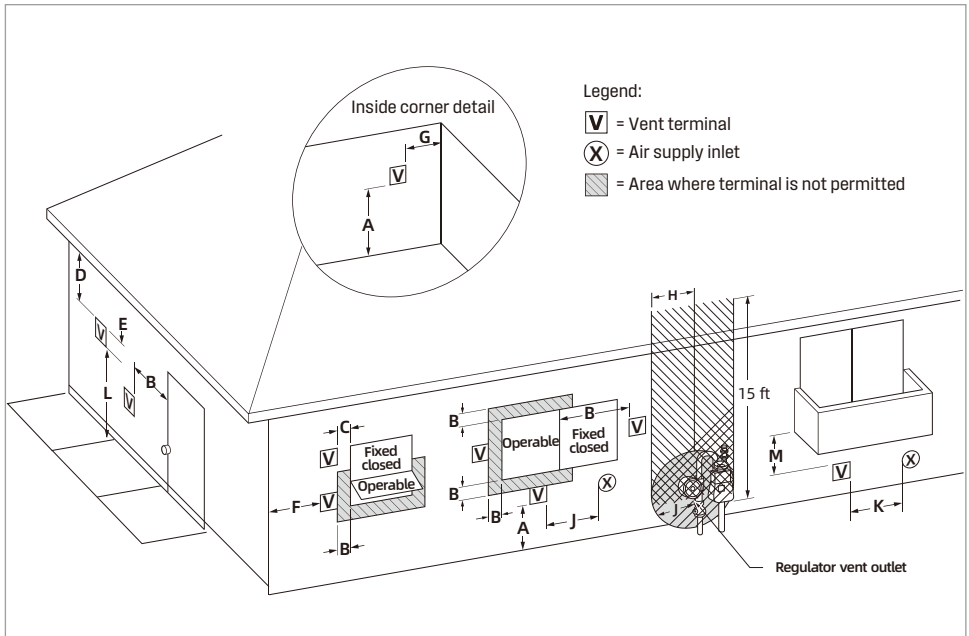

	Description	US installations ¹
A =	Clearance above grade, veranda, porch, deck, or balcony	12 in (30 cm)
B =	Clearance to window or door that may be opened	4 ft (1.2 m) below or to side of opening; 1 ft (300 mm) above opening
C =	Clearance to permanently closed window	*
D =	Vertical clearance to ventilated soffit located above the terminal within a horizontal distance of 2 ft (61 cm) from the center line of the terminal	*
E =	Clearance to unventilated soffit	*
F =	Clearance to outside corner	*
G =	Clearance to inside corner	*

	Description	US installations ¹
H =	Clearance to each side of center line extended above meter/ regulator assembly	.
I =	Clearance to service regulator vent outlet	.
J =	Clearance to nonmechanical air supply inlet to building or the combustion air inlet to any other appliance	4 ft (1.2 m) below or to side of opening; 1 ft (300 mm) above opening
K =	Clearance to a mechanical air supply inlet	3 ft (91 cm) above if within 10 ft (3 m) horizontally
L =	Clearance above paved sidewalk or paved driveway located on public property	Vents for Category II and IV appliances cannot be located above public walkways or other areas where condensate or vapor can cause a nuisance or hazard.
M =	Clearance under veranda, porch deck, or balcony	.

Notes: ¹In accordance with the current ANSI Z223.1/NFPA 54, National Fuel Gas Code

Clearance to opposite wall is 24 in. (60 cm).	
<p>[1] A vent shall not terminate directly above a sidewalk or paved driveway that is located between two single family dwellings and serves both dwellings.</p> <p>[2] Permitted only if veranda, porch, deck, or balcony is fully open on a minimum of two sides beneath the floor.</p>	<p>* Clearances are in accordance with local installation codes and the requirements of the gas supplier.</p>

If locally adopted installation codes specify clearances different than those illustrated, then the most stringent clearance shall prevail.

36 inches minimum from the top of the water heater to the overhang. The area under the overhang must be open on 3 sides

3.7 Termination Clearances for External (Outdoor) Water Heaters

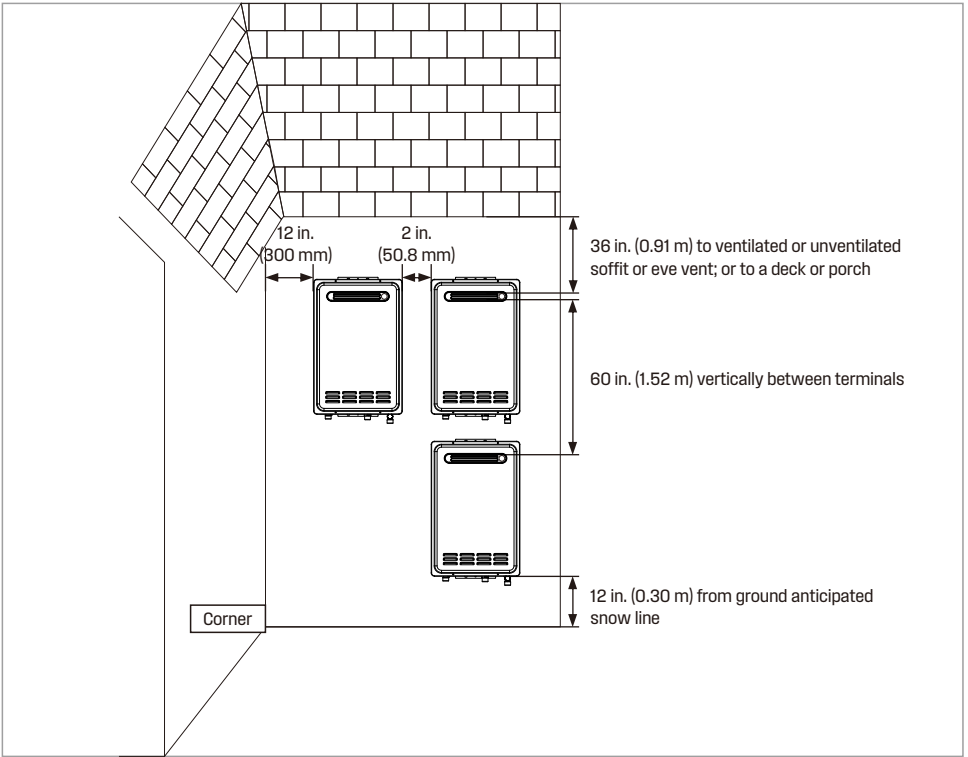

3.8 Mount to Wall

1. Identify the installation location and confirm that the installation will meet all required clearances.



NOTICE

The water heater must be installed in an upright position. Do not install upside down or on its side.

2. As shown on the below, first install the mounting hole on the wall. The upper mounting hole is fixed by the expansion screw, and the lower mounting hole is inserted into the plastic plug. Hang the water heater, place the washer and nut on top, and tighten the nut. Screw on the wooden below.

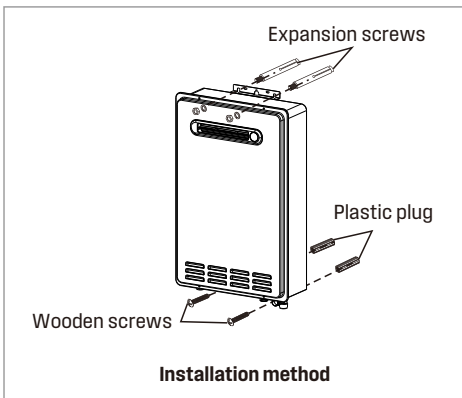

3.9 Gas And Gas Pipe Specifications



WARNING

- First check that the gas type matches the nameplate.
- Make sure that all gas regulators in use are operating properly and provide gas pressure within the specified range as shown below. Excessive intake pressure can cause serious accidents.
- Failure to follow these warnings can result in serious personal injury, carbon monoxide poisoning or death.

- Maximum and minimum gas pressure:

Gas type	Intake pressure
Natural Gas	Min. 3.5" W.C. (0.87kPa) Max. 10.5" W.C. (2.61kPa)
Propane	Min. 8.0" W.C. (1.99kPa) Max. 13.0" W.C. (3.23kPa)

- Inlet gas pressures outside the above range of values may adversely affect the performance of the water heater. These pressures are measured when the water heater is fully operational.
- The intake pressure must not exceed the above maximum values; gas pressures outside the specified range will result in hazardous operating conditions and equipment damage.
- Be sure to disconnect the gas line from the water heater before the main gas supply pressure test is completed to avoid damaging the water heater.
- If the heater's supply pressure is greater than the specified maximum, a pressure regulator is required. The regulator must reduce the gas pressure to within acceptable limits.
- Install the gas regulator according to the manufacturer's instructions.
- The regulator must be sized for the water heater input and provided with the specified pressure listed on the nameplate.
- It is recommended that there be at least 3 ft (1 m) of tubing between the regulator outlet and the water inlet gas connection in the absence of a minimum installation distance.

3.10 Gas Connection



WARNING

1. A licensed professional must install the gas supply.
2. Turn off 120v power supply.
3. Turn off the gas.
4. Gas is flammable. Do not smoke or provide other ignition sources while working with gas.
5. Do not turn on the water heater or gas until all fumes are gone.

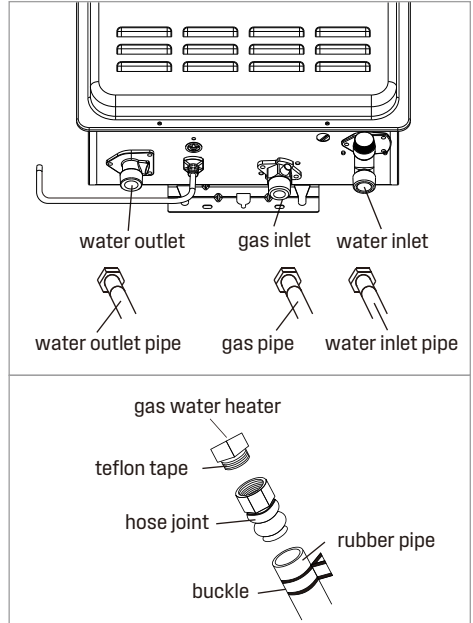

NOTICE

Use sealant tape or other approved sealing method on the threads for a secure, no water or gas leakage.

1. Install a manual gas shut-off valve between the water heater and the air supply line.
2. When the gas connection is completed, the gas leak test must be performed by applying soapy water to all gas fittings and observing the air bubbles or using a gas leak detection device.
 - During any system stress test where the test pressure exceeds 1/2 psi (3.5 KPa), it must be the water heater and its separate shut-off valve are disconnected from the air supply piping system.
 - During pressure testing of any gas supply piping system with a test pressure equal to or less than 1/2 psi (3.5 KPa), the water heater must be isolated from the air supply piping system by closing its separate manual shut-off valve.
3. Always remove any debris and/or water gas lines before connecting to the air intake.



NOTICE

Do not use this product if any parts are underwater. Contact the installer or service agency immediately to replace the flooded water heater. Do not try to repair the heater. Replacement must be done!

3.11 Water Connection



WARNING

Do not use this product if any parts are underwater. Contact the installer or service agency immediately to replace the flooded water heater. Do not try to repair the heater. Replacement must be done!



NOTICE

Do not reverse the hot and cold inlet connections of the water heater. If connected in reverse, the water heater will not start properly.

1. All piping, fittings, valves and other components, including welding materials, must be suitable for potable water systems.
2. The on/off valve must be installed in the cold water inlet of the water heater between the main water supply line and the water heater.
3. Flush the water line to remove any debris before installing the water heater.
4. There is a wire mesh filter in the cold water inlet for filtering debris into the heater. This requires regular cleaning to maintain optimal flow.

3.12 Pressure Relief Valve

The water heater has a built-in high temperature disconnect switch as a standard safety function (called a Hi-limit switch), so a "pressure only" safety valve is required.

- The unit is not equipped with an approved pressure reducing valve.
- An approved pressure relief valve must be installed at the hot water outlet.
- The pressure relief valve must comply with ANSI Z 21.22 • CSA 4.4. Installation must comply with local regulations.
- The pressure relief valve must be rated up to 150 psi and to at least the maximum Btu/hr of the appliance.
- The drain line of the pressure reducing valve must be guided so that hot water does not splash out and cause damage or personal injury.
- Connect the drain hose to the pressure relief valve so that the end of the tube is 6 inches (152 mm) from the floor. The tube must be completely drained without any bends or blockages.
- If the pressure relief valve is periodically discharged, this may be due to thermal expansion.
- In the closed water supply system. Please contact your water supplier or local plumbing professional to find out how to correct this situation. Do not block the pressure relief valve.
- The pressure relief valve must be manually operated periodically to check that it is operating correctly. Before manually operating the valve, check that the pressure relief valve is vented in a safe place.
- Do not place a valve between the safety valve and the water heater.

3.13 Electrical Connections



WARNING

- Comply with the electrical code requirements of local authorities with jurisdiction. If there is no such requirement, please follow the current version of the National Electrical Code ANSI/NFPA 70 or the current Canadian version of CSA C22.1 Canadian Electrical Code Part 1.
- When repairing or replacing parts in the water heater, mark all wires before Disconnect to make it easy to reconnect. Incorrect wiring can result in incorrect and dangerous operation. Confirm correct operation after repair.
- Failure to follow these warnings can result in personal injury or death.

1. The water heater must be grounded. Do not connect the ground wire to a gas or water pipe.
2. The water heater requires a 120 VAC, 60 Hz power supply and is properly grounded.
 - For maintenance reasons, appropriate disconnects (i.e. on/off switches, power plugs, etc.) must be provided to control the main power supply to the water heater. (Must comply with local regulations.)
 - Connect the power supply to the water heater exactly as shown in the wiring diagram.
3. The plug of the water heater is not plugged into the standard American three-pin plug, and the socket must be properly grounded.
4. A surge protector is recommended to protect the equipment from power surges.

3.14 Wired Controller

- The water heater can be installed with up to three wired controllers. Each wired controller has two functions which can adjust the set temperature and indicate the error code.
- **PRIORITY** function: The controller that is activated first (i.e. button is pressed) is given **PRIORITY** function, and can freely adjust the temperature. Remaining controllers will display the set temperature however will not be able to make any adjustments. After a 15 minute period of inactivity the priority on the first remote will cease and priority can then be assigned to another remote by activating it (i.e. a button is pressed). Then the new controller has priority and the cycle repeats.
- **Default setting temperature:** At the initial power on, the setting temperature will be the same as the value set on DIP switch. After the initial use, it will remember the former setting temperature.
- All water heater models have self diagnostic function for safety and convenience when troubleshooting. If there is a problem with the installation or the unit, it will display a numerical error code on the wired controller (or the LED of the computer board will be blink.)

Wired controller installation requirements

- The wired controllers are splash resistant, however should not be positioned where it can be splashed directly & should be appropriately sealed between the surface of the wall & controller.
- The wired controller can be installed in the bathroom provided it is correctly installed.

3.14.1 Wired Controller Installation

Choose a convenient location to place the wired controller base. The connection between the wire controller and the water heater should be reasonably arranged according to the specific environment. Fix the bottom controller holder with the two screws ST4x16 mm provided and place the controller into the bracket.

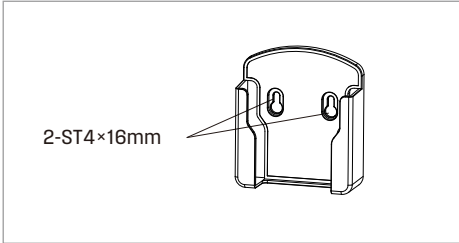

3.14.2 Connection of Wired Controller Wiring to the Water Heater

1. Turn off the power supply to the water heater.
2. Connect the first controller only and turn on the power supply to the water heater.
3. Turn off the first controller by pressing the "⏻" button (LED light will turn off).
4. Continue to connect any additional wired control wires to the remote terminals directly.
5. DO NOT jump or short-circuit wires otherwise the PCB may become damaged.
6. Return the front cover.

DO NOT turn on the remote until instructed.
7. Activate the first remote by pressing & holding the "—" button for 5 seconds until a single beep sounds. Then press & hold the "+" button for 5 seconds until the LED screen lights up.
8. Adjust the on screen value to set the ID (available ID's include -0, -1, -2). Press the "⏻" button to confirm (The ID of the wired control cannot be repeated).
9. Repeat for all additional controllers.
10. Controllers can now be turned on and will operate as per the PRIORITY function (refer to 5.4 How to Set the Temperature).

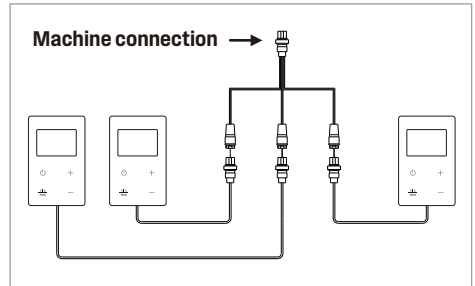

3.15 Initial Test Run



WARNING

For your safety, please read before operation.

- Check for leaks in the gas and water connections for the first time before the ignition.
- Open the main gas supply valve of the unit by hand only to avoid any sparks. Never use tools. If the knob does not turn by hand, do not attempt to force rotation; call a qualified service technician. Forced repairs may result in a fire or explosion due to a gas leak.
- Always check for leaks at the bottom of the unit, as some gases are heavier than air and may settle toward the floor.
- Check gas pressure. See "6.8 Gas pressure test position".
- Do not attempt to manually ignite the burner. It is equipped with an electronic ignition device that automatically ignites the burner.
- Check that the water heater is ventilated and that the flammable air is normal.
- Do not use this product if it is in contact with water or immersed in water. Contact a qualified installer or service facility immediately to replace the water heater. Do not attempt to repair the device! Must be replaced!



WARNING

If you smell gas:

- Do not attempt to start the water heater.
- Do not touch any electric switch.
- Do not use any mobile phones in your building. Call your gas supplier immediately from your neighbor's phone. Follow the instructions of the gas supplier.
- If you are unable to contact your gas supplier, please call the fire department.
- Failure to follow these warnings can result in fire or explosion, resulting in serious injury or death.

The user confirms that the water heater is installed correctly before the initial use, and carefully checks whether the connection is correct and there is no leakage. After confirming, please follow the steps below:

Initial Test Run		
1	Turn on the water heater's 120v, 60 Hz power supply.	
2	Remove debris from the inlet screen.	
3	Open the valve on the inlet water.	
4	Turn on the hot water tap, make sure there is water flowing out, then turn off the hot water tap.	
5	Open the manual gas valve.	
6	Press the switch button on the controller and set the desired hot water temperature.	
7	When you turn on the hot water tap, you can enjoy the constant flow of hot water.	

4 Operation

4.1 Safe Operation

FOR YOUR SAFETY READ BEFORE OPERATING

WARNING: If you do not follow these instructions exactly, a fire or explosion may result causing property damage, personal injury or loss of life.

- A. This appliance does not have a pilot. It is equipped with an ignition device which automatically lights the burner. Do not try to light the burner by hand.
- B. **BEFORE OPERATING** smell all around the appliance area for gas. Be sure to smell next to the floor because some gas is heavier than air and will settle on the floor.

WHAT TO DO IF YOU SMELL GAS

- Do not try to light any appliance.
 - Do not touch any electric switch; do not use any phone in your building.
 - Immediately call your gas supplier from a neighbor's phone. Follow the gas supplier's instructions.
 - If you cannot reach your gas supplier, call the fire department.
- C. Use only your hand to turn the gas shutoff valve. Never use tools. If the valve will not turn by hand, don't try to repair it, call a qualified service technician. Force or attempted repair may result in a fire or explosion.
- D. Do not use this appliance if any part has been under water. Immediately contact a qualified installer or service agency to replace a flooded water heater. Do not attempt to repair the unit! It must be replaced!

OPERATING INSTRUCTIONS

1. STOP! Read the safety information above on this label.
2. Set the thermostat to lowest setting.
3. Turn off all electric power to the appliance.
4. Do not attempt to light the burner by hand.
5. Turn the gas shutoff valve located on the outside of the unit to the closed position.
6. Wait five (5) minutes to clear out any gas. If you then smell gas, STOP! Follow "B" in the safety information above on this label. If you don't smell gas, go to the next step.
7. Turn the gas shutoff valve located on the outside of the unit to the open position.
8. Turn on all electrical power to the appliance.
9. Set thermostat to desired setting.
10. If the appliance will not operate, follow the instructions in "To Turn Off Gas to Appliance" and call your service technician or gas supplier.

TO TURN OFF GAS TO APPLIANCE

1. Set the thermostat to lowest setting.
2. Turn off all electric power to the appliance if service is to be performed.
3. Turn the gas shutoff valve located on the outside of the unit to the closed position.



WARNING

It is absolutely forbidden to use this water heater without installing a smoke exhaust pipe.



DANGER

Steam from flammable liquids can explode and catch fire, causing death or severe burns.

Do not use or store flammable products such as benzene, solvents or adhesives in the same room or area near the water heater.

Read and follow the water heater warnings and instructions. If the user manual is missing, contact your retailer or manufacturer.

Save flammable products:

1. Keep away from the heater.
2. In an approved container.
3. Closed, children are not in contact.
4. The water heater has a main burner that can be turned on at any time and ignites flammable vapors.

Steam:

1. Can't see.
2. It is heavier than air.
3. Take a long road on the floor.
4. Can be transported from other rooms to the main burner by air flow.



DANGER

1. Water temperature above 125 °F (52 °C) will immediately cause severe burns or burns.
2. Children, the disabled and the elderly are at the highest risk of being burned.
3. Test the water temperature before bathing or showering.
4. The outlet temperature of the water heater is set to 107 °F (42 °C). If the water temperature you need is lower than this setting, please follow the instruction manual.

5. Use this heater at your own risk. Test the water temperature before showering. Do not leave children or infirm unattended. For available temperature limit valves, please consult your local water supply company [pipeline retailer].



DANGER

Pressure relief valve hot water supply system unit complying with safety valve and automatic shut-off gas standard, ANSI Z 21. 22:csa 4.4, should be installed at the manufacturer's designated position during installation.

Pressure relief device for safe operation of water heaters. Do not disassemble or block the safety valve. No valves shall be provided between the safety valve and the water heater. The relief valve should be placed in a position where it will not cause damage. Also, no other reducer fittings or other restrictions may be placed on the drain line to limit flow. For installation and maintenance of pressure relief valves, see the installation manual heading "Relief Valves" Valve Discharge Lines and other safety precautions.

4.2 Wired Controller

The wired controller is able to adjust the output temperature in the range of 95 °F (35 °C) to 158 °F (70 °C) in one degree increments.

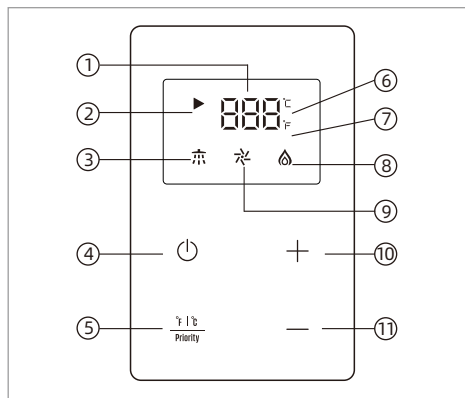

- ① Display setting temperature
Display fault code
Display water temperature
- ② Priority icon
- ③ Shower signal
- ④ Switch button
- ⑤ Fahrenheit/Celsius Priority
- ⑥ Celsius display
- ⑦ Fahrenheit display
- ⑧ Flame
- ⑨ Blower
- ⑩ Heat up button
- ⑪ Heat down button

⏻ **Switch button:**

Turn the water heater on or off.

+ **Heat up button:**

Increase the water heater temperature.

— **Heat down button:**

Reduce the water heater temperature.

Priority **Fahrenheit/Celsius Priority button:**

1. Press toggle degrees Celsius Fahrenheit.
2. When using multiple remote controls, press and hold to enable or disable priority.



WARNING

There is a hot water scald potential if the thermostat is set too high. Should overheating occur or the gas supply fails to shut off, turn off the manual gas control valve to the appliance.



CAUTION

- While any hot water is being provided, the temperature setting can only be adjusted between 95 °F (35 °C) and 158 °F (70 °C).
- There may be a variation between the temperature displayed on the temperature controller and the temperature at the tap due to weather conditions or the length of pipe to the water heater.

■ **Controller Thermometer**

°F	95	96	98	100	102	104	105	107	109
°C	35	36	37	38	39	40	41	42	43
°F	111	113	114	116	118	120	122	123	125
°C	44	45	46	47	48	49	50	51	52
°F	127	129	131	132	134	136	138	140	141
°C	53	54	55	56	57	58	59	60	61
°F	143	145	147	149	150	152	154	156	158
°C	62	63	64	65	66	67	68	69	70

* Factory setting (default): 107 °F(42 °C).

■ **How to use the mixing valve:**

1. Turn on the cold water tap.



2. Mix hot and cold water to get the proper water temperature.



3. When the use is over, close the water valve.



°F	°C	Time to produce serious burn
120	49	More than 5 minute
125	52	One and a half to two
130	54	About 30 seconds
135	57	About 10 seconds
140	60	Less than 5 seconds
145	63	Less than 3 seconds
150	66	About 1.5 seconds
155	68	About 1 seconds



WARNING

Minors are not allowed to operate the water heater themselves unless accompanied by a guardian.

- If the temperature is set too high, it may cause hot water burns.
- If overheating occurs or the gas supply cannot be turned off, turn off the manual switch gas control valve to the unit.



WARNING

Temperatures above 125 °F (52 °C) can cause severe burns or burns. The risk of injury to children, the disabled and the elderly is high.

5 Troubleshooting

Error Code	Possible Cause	Fault Handling
E0	<ol style="list-style-type: none"> 1. The outlet water temperature sensor connector is loose or has poor contact. 2. The outlet water temperature sensor is damaged (open circuit, short circuit or metal parts). 	<ol style="list-style-type: none"> 1. Clamp the outlet water temperature sensor terminal. 2. Replace the water temperature sensor.
E1	<ol style="list-style-type: none"> 1. The gas valve is not open. 2. The gas supply pressure or gas composition is abnormal, causing accidental flameout. 3. The igniter, ignition needle is damaged or the line is faulty. 4. Damage to the flame induction needle or wire failure. 5. The combustion system (burner, nozzle, air control panel, proportional valve, sectional valve) is damaged, the specifications are inconsistent or the wiring is wrong, resulting in abnormal combustion. 6. The control program or parameter settings are incorrect, resulting in unstable combustion. 7. The fan speed is abnormal, resulting in unstable combustion. 	<ol style="list-style-type: none"> 1. Open the gas valve to ensure that the water heater can get normal gas supply. 2. Confirm that the gas type and pressure meet the requirements of the water heater. 3. Check if the igniter, ignition pin and circuit are damaged, and replace the damaged parts. 4. Check if the flame induction needle is damaged and replace the damaged parts. 5. Check if the combustion system is damaged, if the wiring is wrong, and replace the damaged parts. 6. Check whether the program and parameters meet the values in the parameter table. 7. The wind speed of the fan is abnormal. Check whether the program and parameters meet the values in the parameter table.
E2	<ol style="list-style-type: none"> 1. The feedback pin is bent and in contact with other metal parts. 2. The feedback pin plug-in terminal is loose and hits the metal part. 3. Feedback pin wire is broken. 	<ol style="list-style-type: none"> 1. Replace the ignition feedback needle assembly. 2. Plug the feedback pin terminal correctly and firmly into the feedback pin. 3. Check if the wire is disconnected and replace the wire.
E3	<ol style="list-style-type: none"> 1. The thermostat opens or the wire is faulty. 2. The gas supply pressure or gas composition does not match, causing abnormal combustion. 3. The control program or parameter settings are incorrect, resulting in abnormal requirements combustion. 4. The combustion system is damaged or the specifications are inconsistent, resulting in abnormal combustion. 	<ol style="list-style-type: none"> 1. Check the temperature controller or circuit and replace the damaged parts. 2. Confirm that the gas type and pressure meet the requirements of the water heater. 3. Check whether the program and parameters meet the values of the parameter table. 4. Check the combustion system for damage and replace damaged parts.

Error Code	Possible Cause	Fault Handling
E4	<ol style="list-style-type: none"> 1. The inlet water temperature sensor connector is loose or has poor contact. 2. The inlet water temperature sensor is damaged (open circuit, short circuit or metal parts). 	<ol style="list-style-type: none"> 1. Clamp the water temperature sensor terminal. 2. Replace the water temperature sensor.
E5	<ol style="list-style-type: none"> 1. The fan signal is not detected or the speed is too low in the system startup 5S. 2. During operation, the fan speed is not detected or 2S consecutively, or the speed is too low. 3. The power supply voltage is too low, causing the fan speed to slow down. 	<ol style="list-style-type: none"> 1. The fan assembly, controller damage or line failure, causing the fan not to run or the speed is too low, check the fan, the main controller is damaged, the wiring is damaged, loose, replace the damaged parts. 2. Confirm whether the power supply and fan voltage meet the design requirements.
E6	<ol style="list-style-type: none"> 1. The gas supply pressure or gas composition does not match, causing abnormal combustion. 2. The control program or parameter settings are incorrect, resulting in abnormal combustion. 3. The water temperature sensor specifications do not match, the display temperature is much higher than the actual temperature. 4. The combustion system is damaged or the specifications are inconsistent, resulting in abnormal combustion. 5. The heat exchanger fins of the heat exchanger are poorly welded, and the heat transfer is slow. After the water valve is closed, the water in the tube is continuously heated. 	<ol style="list-style-type: none"> 1. Confirm that the gas type and pressure meet the requirements of the water heater. 2. Check whether the program and parameters meet the values of the parameter table. 3. Test whether the actual water outlet temperature and the wired controller display temperature are close ($\pm 3^{\circ}\text{C}$), and replace the wrong outlet water temperature sensor. 4. Check the combustion system for damage and replace damaged parts. 5. Detect if the heat exchanger fins are poorly welded and replace the damaged parts.
E7	<ol style="list-style-type: none"> 1. The valve connector is loose or has poor contact. 2. The valve is short-circuited. 	<ol style="list-style-type: none"> 1. Clamp the water temperature sensor terminal. 2. Check if the valve coil is short-circuited and replace the damaged parts.

Error Code	Possible Cause	Fault Handling
E8	<ol style="list-style-type: none"> 1. During operation, the fan speed continuously exceeds the set value of 5S speed. 2. The outdoor wind pressure is too high, and the fan speed exceeds the upper limit of the speed. 3. A large amount of carbon in the heat exchange fins (when the gas source is used incorrectly), causing blocked, and the fan speed increase exceeds the upper limit of the speed. 	<ol style="list-style-type: none"> 1. Check if the exhaust passage is blocked. 2. Stop starting, and start after no strong wind on the outdoor. 3. Remove the heat exchanger, use a brush to gently clean the carbon on the fins, and ensure that the type and pressure of the gas used subsequently meet the requirements of the water heater.
En	<p>In order to prevent oxygen deficiency, some models have timing protection. Please turn off the tap and use it after a while.</p>	<ol style="list-style-type: none"> 1. Set the appropriate timer duration according to your usage habits. The automatic shut-off timer can be set to 20, 30, 40, 50, or 60 minutes. 2. From the factory, the timer function is set to "OFF" by default, meaning the timer function is disabled.

Fault alarm release and reset method: If the above code appears, please check the gateway, the gas path is normal, press "Switch button" to turn off or turn off the power to restart. The water heater is restored to normal use. If the above operations cannot be resumed, please notify the after-sales service personnel.

6 Maintenance

The water heater should be checked at least once a year or as necessary by a licensed technician. If repairs are needed, any repairs should be done by a licensed technician. The water heater's lifetime may be extended by regular maintenance.



WARNING

- Turn off the electrical power supply and close the manual gas control valve and the manual water control valve before servicing.
- Label all wires prior to disconnection when servicing controls. Wiring errors can cause improper and dangerous operation.
- Verify proper operation after servicing.
- Should overheating occur or the gas supply fails to shut off, turn off the manual gas control valve to the appliance.

- Have a bucket or container to catch the water from the unit's drain plugs. Unscrew the drain plugs to drain all the water out of the unit.
- Wait a few minutes to ensure all water has completely drained from unit.

Clean the filter:

- Check the water filter located within the cold inlet. With a tiny brush, clean the water filter of any debris which may have accumulated and reinsert the filter back into the cold water inlet.
- Securely screw the drain plugs back into place. Hand-tighten only.

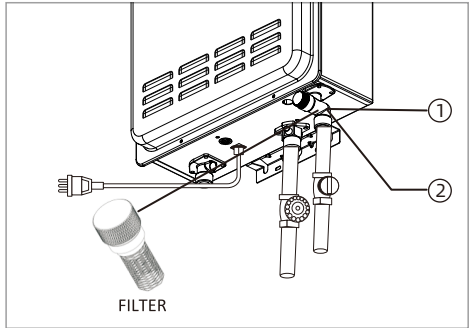

- ① Remove by turning counter clockwise and then clean and replace.
- ② 1. Turn off the water inlet supply valve.
2. Open a hot water tap to release the line pressure.

6.1 Vent System

- Be sure that all openings for combustion air are not blocked. If blocked, remove obstruction.
- Check that the opening for exhaust is not blocked. If blocked, shutoff the water heater's combustion. And then after a while, remove obstruction.
- DO NOT touch while unit operating, otherwise you might get burnt due to high temperature.
- Check the gas pressure.
- Keep the area around the water heater clear. Remove any combustible materials, gasoline or any flammable vapors and liquids.
- Not obstructing the flow of combustion and ventilation air.

6.3 Clean Burners

It is imperative that control compartments, burners, and circulating air passageways of the appliance be kept clean.

Clean as follows:

1. Turn off and disconnect electrical power. Allow to cool.
2. Close the water shut off valves. Remove and clean the water inlet filter.
3. Remove the front panel by removing 4 screws.
4. Use pressurized air to remove dust from the main burner, heat exchanger, and fan blades. Do not use a wet cloth or spray cleaners on the burner.
Do not use volatile substances such as benzene and thinners. They may ignite or fade the paint.
5. Use soft dry cloth to wipe cabinet.

6.2 Unit Draining and Filter Cleaning

- Close the manual gas shut off valve.
- Turn off the power supply to the water heater.
- Close the manual water shut off valve.
- Open all hot water taps in the house (Bathroom, kitchen, laundry, etc.). When the residual water flow has ceased, close all hot water taps.

6.4 Visual Inspection of Flame

Verify proper operation after servicing.

The burner must flame evenly over the entire surface when operating correctly. The flame must burn with a clear, blue, stable flame. See the parts breakdown of the burner for the location of the view ports. The flame pattern should be as shown in the figures below.

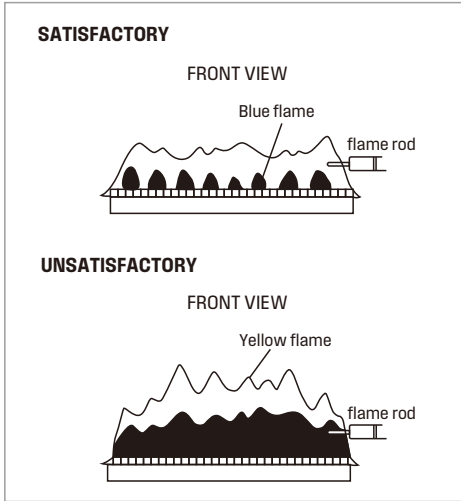

6.5 Pressure Relief Valve Maintenance



WARNING

Testing the pressure relief valve should only be performed by a licensed professional. Water discharged from the pressure relief valve could cause severe burns instantly or death from scalds.



WARNING

Before manually operating the pressure reducing valve, check that the hot water is discharged in a safe place. If water cannot escape from the end of the drain, turn off the air supply and turn off the power and call a qualified person to determine the cause. See the manufacturer of the pressure relief valve for inspection and maintenance requirements.



WARNING

Do not check the safety valve when the water heater is in normal operation to avoid hot water burns.

- The dirt will directly affect the normal function of the safety valve function. It requires hot water system maintenance of anti-fouling and anti-scaling cleaning.
- The user must check the relief valve at least once a year. When checking, turn off the water heater's power supply and gas. Turn on the water inlet switch to create pressure in the water system. Then gently open relief valve handle until there is water out and then gently close, if there is no water out, indicating that the valve is invalid, this time should immediately turn off the water heater water switch and ask the service personnel to deal with. Before operating the handle, check the discharge line connecting the valve to ensure that the water drained from the valve can be drained to a suitable place.

* This is a concept drawing only.

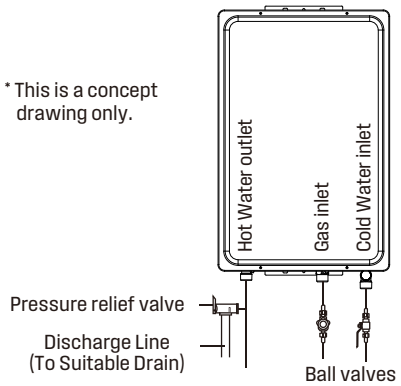

6.6 Freeze Prevention



WARNING

If freezing conditions are expected, turn off water and gas and drain all water from the appliance. If power and the automatic frost protection are connected freezing will be prevented.

- Only the pipes and heat exchanger inside the water heater will be protected.
- Any hot or cold water pipes located outside of the unit will not be protected.
- Proper protection and insulation of these pipes will be required to ensure these are protected from freezing.

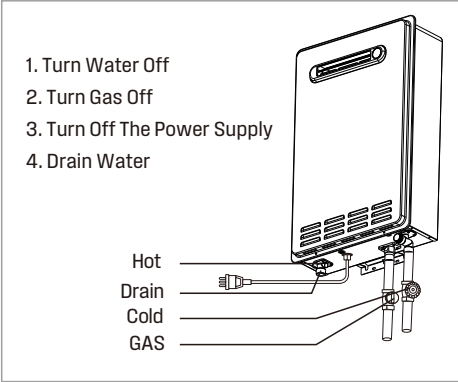

Antifreeze Tips

- When the temperature is below 46.4 °F (8 °C) while above 37.4 °F (3 °C), keep your water heater staying plugged in a 120V 60HZ power supply, the anti-freeze system will automatically heat up to prevent the water heater from damages. No manual work is needed.
- If the machine is not used for a long time, or if the ambient temperature is below 32 °F (0 °C) and the machine cannot be kept powered with electricity and gas, it is necessary to drain the water from the water heater to prevent damage due to freezing. And here is the process:
 1. Turn off the gas shut-off valve.
 2. Power off the water heater and unplug the power supply to the machine.
 3. Turn off the water supply shut-off valve.
 4. Turn on hot water taps in the house, to release the water and pressure in the pipes.
 5. Screw out the drain screw on the hot water outlet.
 6. Remove the inlet water filter from the cold water inlet and it's valve by turning counterclockwise.
 7. Use a bucket to collect the residual water while draining. It may take more than 10 minutes to drain out the water thoroughly.

8. Securely screw the drain screw back in place; and screw the inlet water filter back in place.
9. Before you use the water heater next time, plug it into a 120 V 60 Hz power supply, and power on the water heater, and then open the water supply valve, hot water outlet valve, and the gas valve.



CAUTION

- Please note damages caused by freezing are **NOT** covered under the tankless water heater warranty as an industry standard.
- Please make sure to take all the measures to protect your water heater.

6.7 Minimum Load Adjustment Method

Set the temperature on the controller to 35 °C and increase the inlet water temperature so that the outlet temperature is above 35 °C. It then proves that the water heater is operating at its minimum heat load.

6.8 Gas Pressure Test Position

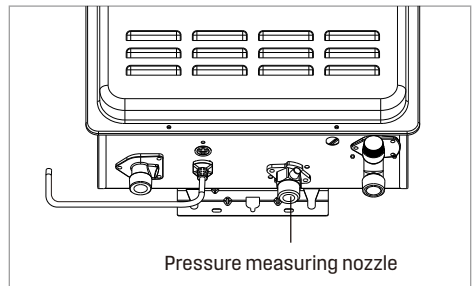

The gas inlet has a pressure measuring nozzle. The inlet gas pressure can be measured by unscrewing the screw.



CAUTION

- Please close the gas valve before connecting the measuring instrument. Avoid accidents such as fires.

7 Wiring Diagram

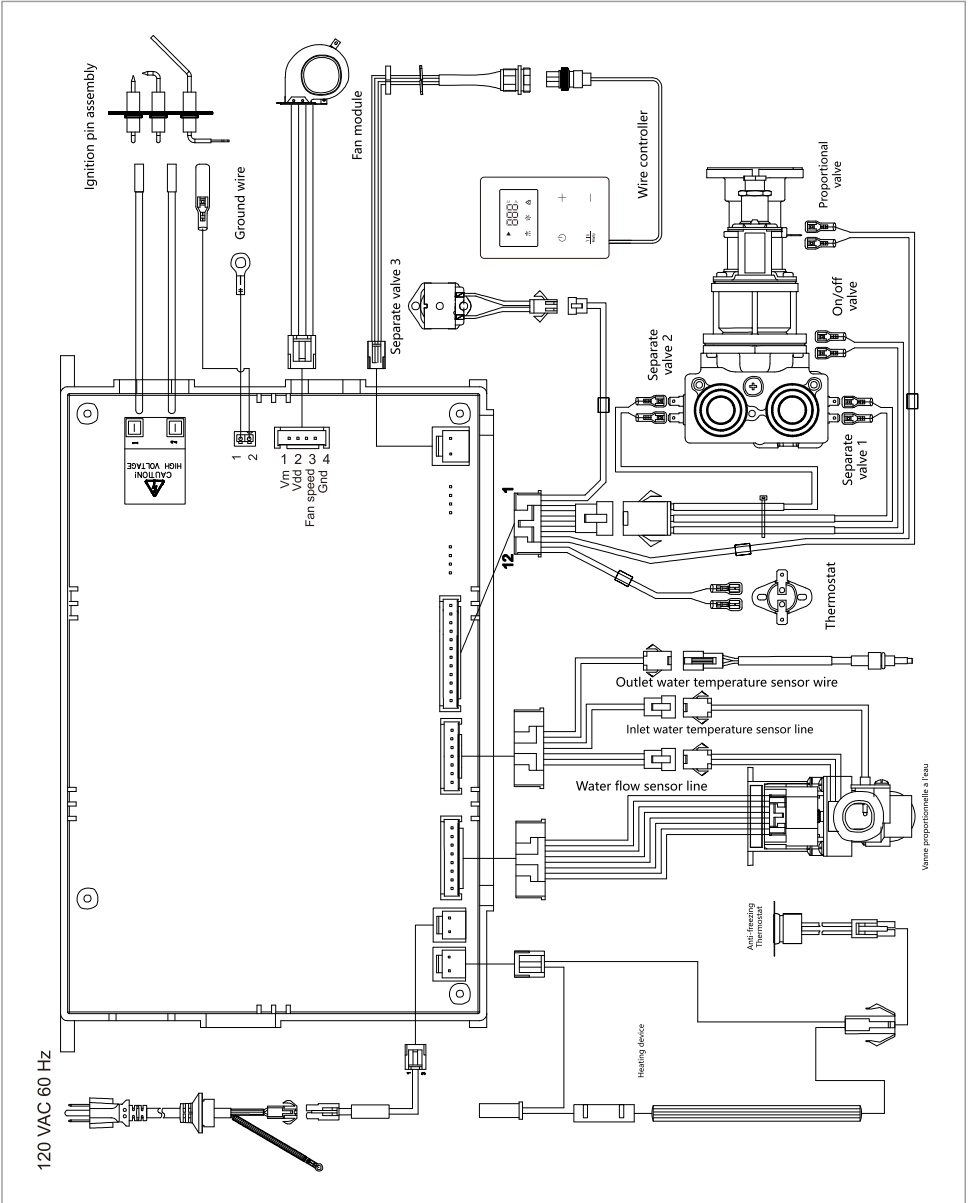

CAUTION

Label all wires prior to disconnection when servicing controls. Wiring errors can cause improper and dangerous operation. Verify proper operation after servicing.

8 Packing List

Check if the following items are included in the water heater.

Order	Description	Quantity
1	Gas water heater	1 piece
2	User manual	1 piece
3	Wired controller	1 piece
4	Expansion screw	2 pieces
5	Plastic plug	4 pieces
6	Installing screws (For Wired controller installation)	2 pieces
7	Wooden screws	2 pieces
8	Warranty	1 piece
9	Quick installation guide	1 piece



Tel: +1 833 566 1779

Email: support@tl.westinghouse.com

® and Westinghouse are trademarks of Westinghouse Electric Corporation.
Used under license by Fogatti Holdings Limited.