

2 General Information

2.1 Function Introduction and Explanation

- The unit is a box less gas fast water heater designed to effectively supply hot water continuously during proper installation.
- Read all installation instructions thoroughly before installing this product.
- If you have any questions or concerns about this device, please consult the manufacturer or its local agent.
- This water heater can only be installed indoors for indoor models.
- The model description is listed on the nameplate, which is located on the side panel of the water heater.

The principle of the water heater is shown below:

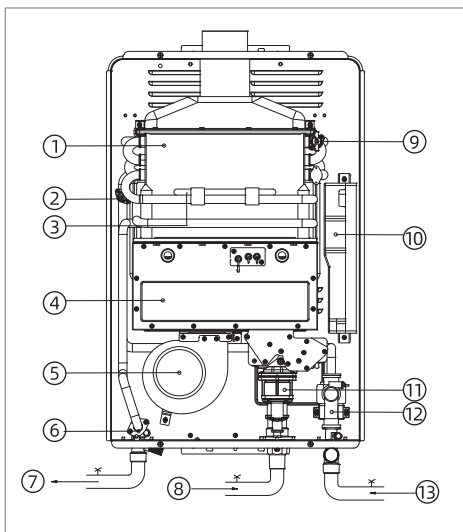

- ① Heat exchanger
- ② Over temperature protection therm
- ③ Heating device
- ④ Burners
- ⑤ Fan module
- ⑥ Water temperature sensor
- ⑦ Hot water
- ⑧ Gas
- ⑨ Anti-freezing thermostat
- ⑩ Computer board
- ⑪ Gas valves
- ⑫ Water control valve flow sensor
- ⑬ Cold water

* This diagram illustrates tankless water heater design concepts only and does not accurately represent the water heater's physical description.

1. A hot water tap is turned on.
2. Water enters the heater.
3. The water flow sensor detects the water flow.
4. The computer initiates the fan motor and sends a signal to the igniter to create an ignition spark.
5. The gas ignites and flames appear within the burner chamber.
6. Water circulates through the heat exchanger and then gets hot.
7. Using thermistors to measure temperatures throughout the water heater, the computer modulates the gas and water valves to ensure proper output water temperature.
8. When the tap is turned off, the unit shuts down.

2.2 Dimensions and Connection Points

This series of gas water heaters with solar linkage function by default:

- a. When it is detected that the inlet water temperature reaches a predetermined value, the water heater does not start;
- b. When the combustion work is started, and the inlet water temperature is less than the set temperature by 4 °F (2 °C), the water heater stops working;
- c. When the combustion work is started, if the inlet water temperature is ≥ 140 °F (60 °C), the water heater stops working.



NOTICE

The images used in this document are for reference purposes only. Components and component locations may vary according to specific product models. Measurements may vary ± 0.38 in. (10 mm).

Controller temperature adjustment range		95~149 °F (35 °C~65 °C)
System start condition	Inlet water temperature	< 113 °F (45 °C)
	Set temperature-inlet water temperature	< 39 °F (4 °C)
Normal combustion conditions	Inlet water temperature	< 140 °F (60 °C)
	Set temperature-inlet water temperature	< 35 °F (2 °C)

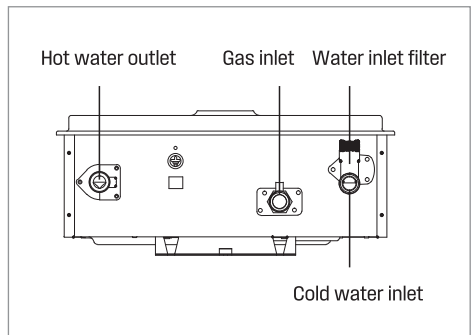
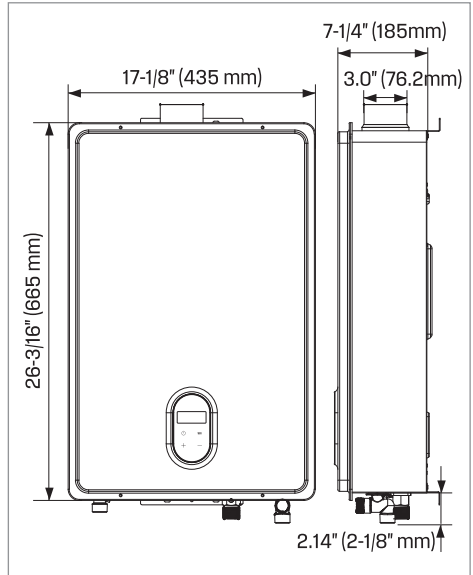

2.3 Technical Parameters

MODEL		HW180	
Part No.		HW180A0G-NG	HW180A0G-LP
Gas Category		NATURAL GAS	PROPANE
Minimum Gas Consumption Btu/h		17,000	
Maximum Gas Consumption Btu/h		180,000	
Hot Water Capacity (Min - Max) *		0.53 - 6.87 GPM (2 - 26 L/min)	
Temperature Setting (no controller)		95-149 °F (35-65°C)	
Maximum Temp Setting		149 °F (65 °C)	
Minimum Temperature Setting		95 °F (35 °C)	
Electrical Data	Normal	40 W	56 W
	Standby	2 W	
	Anti-frost Protection	100 W	
	Max Current	0.57 A	0.70 A
	Fuse	10 A	
Gas Supply Pressure		3.5 - 10.5 inch W.C.	8.0 - 13.5 inch W.C.
By-Pass Control		Fixed	
Type of Appliance		Tankless, Temperature controlled continuous flow gas hot water system	
Connections		Gas Supply: 3/4" MNPT Cold Water Inlet: 3/4" MNPT Hot Water Outlet: 3/4" MNPT	
Ignition System		Direct Electronic Ignition	
Electric Connections		AC 120 Volts, 60Hz	
Water Temperature Control		Simulation Feed forward and Feedback	
Water Supply Pressure		Minimum Water Pressure: 15 PSI (Recommended 30-50 PSI for maximum performance)	
Maximum Water Supply Pressure		150 PSI	

* Minimum flow may vary slightly depending on the temperature setting and the inlet water temperature. Minimum activation flow is 0.53 GPM (2 L/min).

2.4 Component Diagram

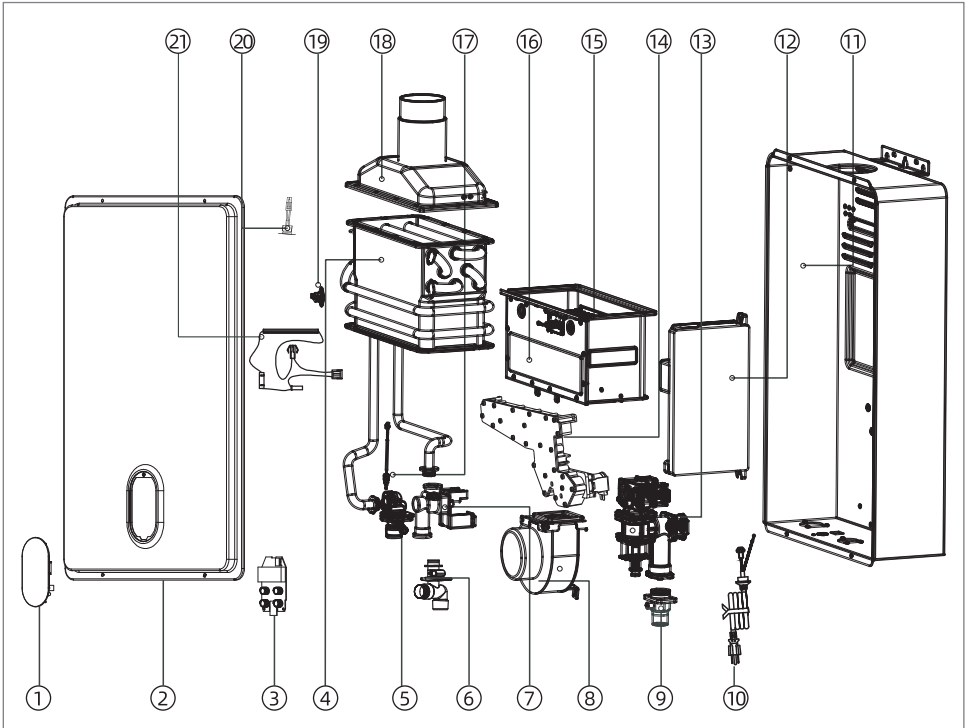

- | | |
|----------------------------|--|
| ① Decoration board | ⑫ Controller |
| ② Front panel | ⑬ Proportional valve |
| ③ Display assembly | ⑭ Manifold |
| ④ Heat exchanger | ⑮ Ignition pin assembly |
| ⑤ Water outlet connector | ⑯ Burner |
| ⑥ Water inlet connector | ⑰ Water outlet temperature sensor |
| ⑦ Water proportional valve | ⑱ Chimney |
| ⑧ Motor fan assembly | ⑲ Over temperature protection thermostat |
| ⑨ Intake connector | ⑳ Anti-freezing thermostat |
| ⑩ Power line | ㉑ Heating device |
| ⑪ Back panel | |