

OWNER'S MANUAL

15-Gallon, BB Zero-Turn Sprayer w/2-Nozzle Boom

(For Bad Boy Zero Turn Mowers)

Model: ZTM-15-2N-BBA
(5303870)

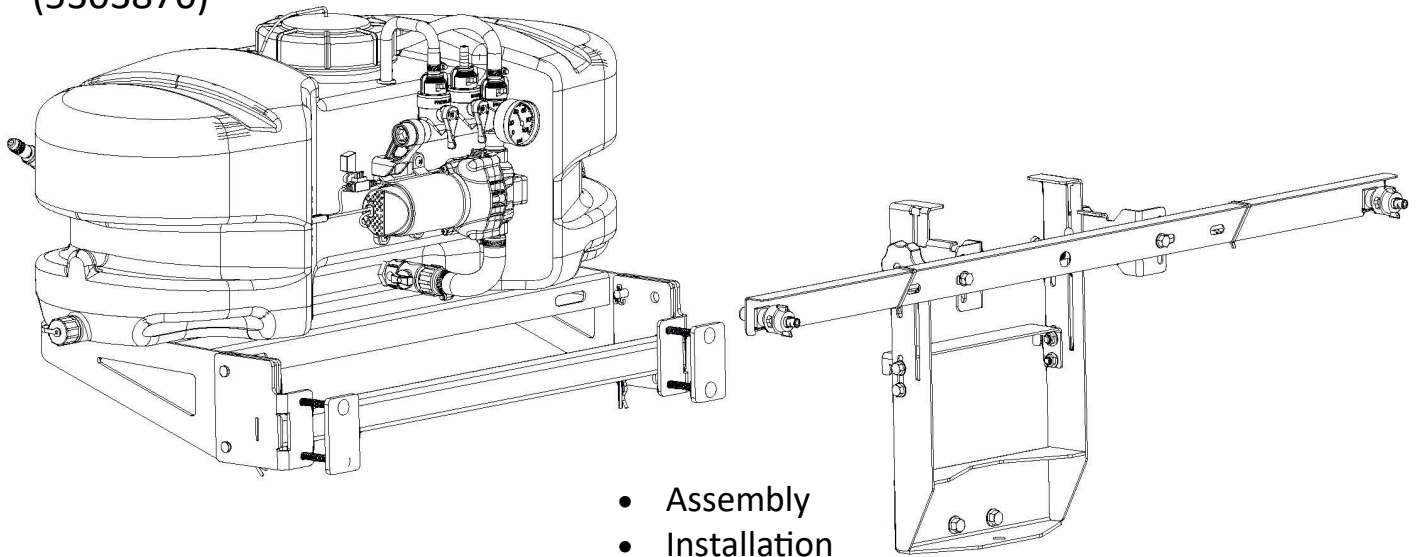

- Assembly
- Installation
- Operation
- Repair Parts

BEFORE RETURNING THIS PRODUCT
FOR ANY REASON, PLEASE CALL

MONDAY-FRIDAY, 8:00 AM to 5:00 PM CST

1-800-831-0027



WARNING: Cancer and Reproductive Harm.
www.P65Warnings.ca.gov



WARNING: To reduce the risk of injury, the user must read and understand the operator's manual before using this product.



www.fimcoindustries.com

1000 FIMCO Lane, P.O. Box 1700, North Sioux City, SD 57049
Toll Free Phone: 800-831-0027 : Toll Free Fax: 800-494-0440

[5001883

(03/26)]

Table of Contents

Warnings	2	Tank Care & Maintenance/Winter Storage.....	10
Technical Specifications.....	3	Pump Exploded View and Parts List.....	11
Safety.....	3	Troubleshooting.....	11 - 13
Sprayer Contents.....	4	Pump FAQs & Sprayer Intended Uses.....	13
Sprayer Assembly.....	5 - 7	Sprayer Exploded View and Parts List.....	14 - 15
Operation	8	Boom Exploded View and Parts List.....	16
Calibration.....	9	Sprayer Dimensions	17
Maintenance During/After Spraying	9	Warranty.....	20

Thank you for purchasing this product. The purpose of this manual is to assist in operating and maintaining this Zero-Turn sprayer.

IMPORTANT

Remove tank lid and be sure the tank is clean and free of any foreign material. Rinse tank out of any tank residue before filling with water to test.

IMPORTANT

After assembly and connecting the pump to a 12V source, it is VERY important to test the sprayer with plain water before actual spraying is attempted. This will enable you to check the sprayer for leaks without the possibility of losing any expensive chemicals.

NOTE: Make sure all hose clamps are tight before testing or spraying for the first time.

Testing the system for leaks with water:

1. Fill the tank part way with water.
2. Turn on the pump and check all fittings.
3. If a leak is detected, fix the leak and re-test.

WARNING



Read and Understand the Owner's Manual before using this sprayer. Test and use in accordance to instructions.

Read and Follow chemical label instructions and wear protective gear when filling, using, cleaning and servicing the sprayer.

Exercise Caution in vehicle handling when towing/hauling a filled sprayer to avoid loss of control or overturning.

Keep Sprayer and Spray materials away from other people, children and pets.

Do Not Turn on Power to the sprayer, until ready to spray in order to avoid unintentional spray release.

Ensure that Spray Nozzles are oriented correctly, spraying straight down before starting sprayer.

Do Not Spray when wind exceeds 4 MPH in order to minimize spray drift.

Do Not Use on steep slopes. A full sprayer could cause loss of control or overturn sprayer and vehicle.

Always operate up and down a slope, never across the face of a slope.

Keep all movement on slopes slow and gradual. Do not make sudden changes in speed, directions or turning. Do not start or stop suddenly when going uphill or downhill.

Stop on level ground, set the parking brake and shut off engine before leaving the operator's position for any reason.

Keep all parts in good condition and properly installed. Fix damaged or worn parts immediately.

Caution should be taken when towing and/or using any sprayer. This sprayer combined with the weight distribution, turning radius and speed of vehicle can result in damage to vehicle and/or sprayer or severe injury or death, if not used properly.

Improper use of this sprayer or handling of chemicals could result in serious injury or illness, or could cause damage to the environment.

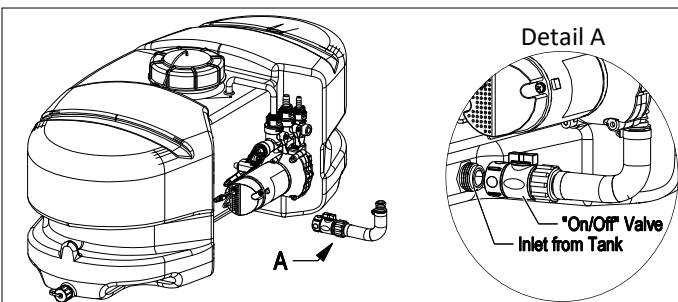

IMPORTANT REMINDER:

This sprayer comes with an On/Off (shut-off) valve located at the inlet location of the tank, towards the underside. (See Detail A). Make sure the valve is in the "open" position before using the sprayer.

**BEFORE RETURNING THIS PRODUCT
FOR ANY REASON, PLEASE CALL**

1-800-831-0027

MONDAY-FRIDAY, 8:00 AM TO 5:00 PM CST

If you should have a question or experience a problem with your Fimco Industries Product: Visit our website @ www.fimcoindustries.com or call the Toll free number above. Our technical support representatives will be happy to help you. In most cases a customer service rep. can resolve the problem over the phone.

To obtain prompt, efficient service, always remember to give the following information....

- Correct Part Description and/or part number
- Model number and Serial Number

Part descriptions and numbers can be obtained from the illustrated parts list section(s) of this manual.

**Retain a copy of your receipt for your unit,
as it will be required to validate any
warranty service.**

**Warranted against manufacturer or workmanship defects
from date of purchase with copy of receipt:**

Homeowner Usage:

**Sprayer - One Year &
Pump-Two Years.**

Commercial Usage:

Sprayer & Pump: 90 Days.



Record your purchase information and attach a copy of your receipt to this manual.

Date of Purchase: _____

Purchased From: _____

Model: **ZTM-15-2N-BBA (5303870)**

Technical Specifications

Model: ZTM-15-2N-BBA (5303870)
(15-Gallon, BB Zero-Turn Sprayer w/2-Nozzle Boom)

Technical Specifications

- 15 Gal. Corrosion-Resistant Polyethylene Tank
- 12 Volt Diaphragm Pump, 2.4 GPM - 60 PSI
- Lever Spray Wand w/15 Ft. Hose (3/8" I.D.)
- 15 Ft. Vertical throw, 30 Ft. Horizontal Throw
- 2-Nozzle Boom Assembly, 80" Spray Coverage
- Corrosion-Resistant Nylon Nozzles
- Check Valve Strainers, 50 Mesh, 5 PSI

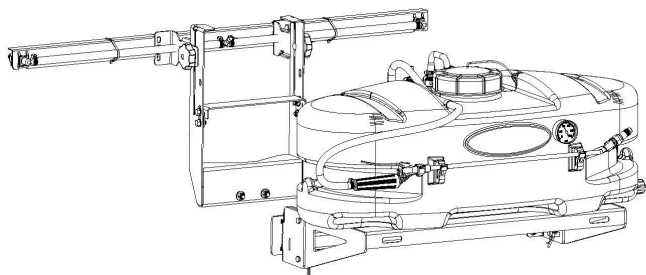

This sprayer may be mounted to a Bad Boy Zero-Turn Mower.

CAUTION: When fully filled with water, this sprayer will weigh approx. 180 Lbs. Always check the vehicle load rating before using this sprayer. Do not exceed the recommended rating.

Safety

- Use for intended purposes only.
- Wear protective clothing, eye protection and chemical resistant gloves when filling, using or cleaning this sprayer.
- Do not allow adults to operate without proper instruction or without having read the owner's manual.
- Always be aware of your surroundings when using. Do not let anyone near while operating any sprayer.
- Slow down before turning and be careful when backing up to avoid any damage to sprayer or your equipment.
- Clear the spray area of people and pets. Restrict access for a period recommended on chemical label.
- Clean up spills immediately per instructions on chemical label.
- Turn off sprayer and relieve any pressure before leaving sprayer unattended.
- Exercise special caution in handling and DO NOT exceed 10 MPH. Exercise extreme caution on sloped or rough surfaces.

Contents of Sprayer Carton:

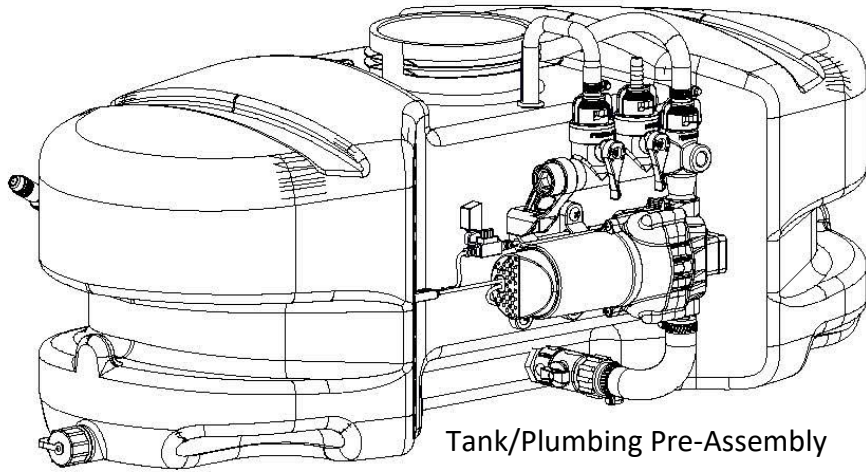

Tank/Plumbing Pre-Assembly

Own-
er's
Manual



2-Nozzle Boom Assembly

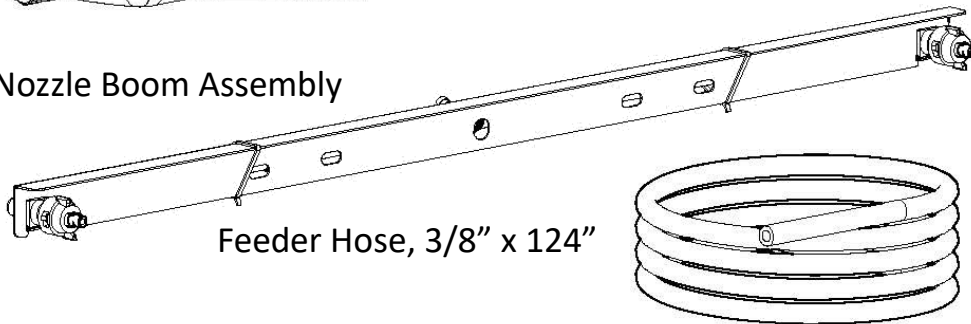

Feeder Hose, 3/8" x 124"

Tank Lid
& Lanyard

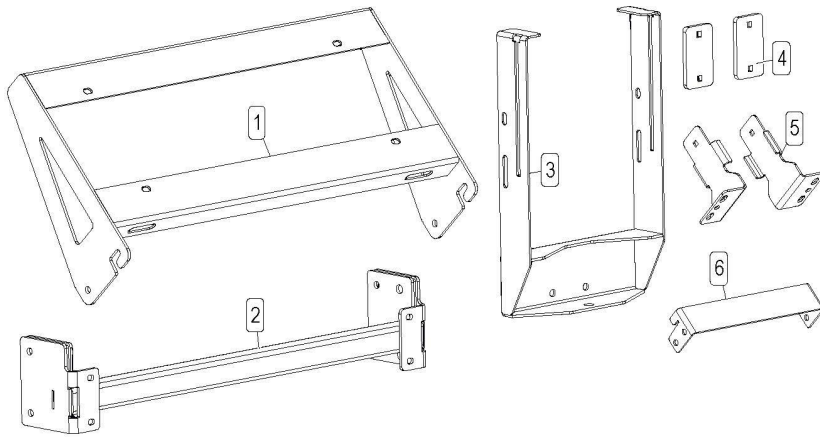

Contents of BB ZT Mount Kit #5283868

(Kit Includes Hardware Parts Bag 5283391)

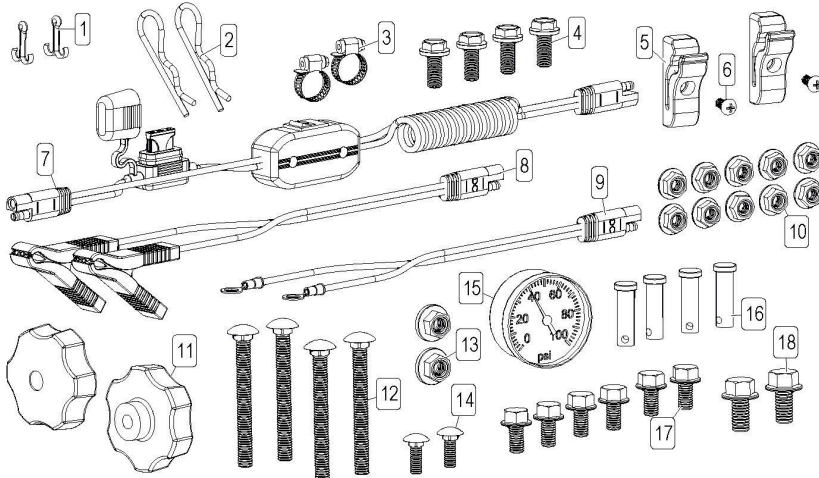

Ref. #	Part #	Description	Qty
1	5283385-BLK	15G ATV ZT Tank Mount	1
2	5283388-BLK	BB Mount Weldment	1
3	5283389-BLK	BB ZT Boom Mount	1
4	5029257-BLK	Bad Boy Mount Plate	2
5	5070614-BLK	ZT Boom Mount	2
6	5070621-BLK	BB ZT Boom Top Support	1

Hardware Parts Bag 5283391

Ref. #	Part #	Description	Qty
1	5101077	Cotter Pin, 1/8" x 1"	2
2	5101065	Hair Pin, #211 x 2.50	2
3	5051144	Hose Clamp (3/8")	2
4	5117323	5/16-18 x 0.75 Fling Hex Bolt	4
5	5053096	Spray Wand Clip	2
6	5117334	#10-24 x 0.50 PH Round Head Screw	2
7	5164336	60" 16AWG 15A Switched Lead w/Fuse	1
8	5164333	36" 16AWG Battery Clamp Ends	1
9	5164334	36" 16AWG Ring Terminal Ends	1
10	5006307	5/16-18 Serrated Fling Hex Nut	10
11	5088026	5 Lobe Knob 1/4-20UNC	2
12	5034550	5/16-18 x 3.00 Carriage Bolt	4
13	5006259	3/8-16 Serrated Fling Hex Nut	2
14	5034481	1/4-20 x 0.75 Carriage Bolt	2
15	5167097	2" Dry 100# Back Mount Gauge	1
16	5101277	Clevis Pin, 3/8 x 1.25	4
17	5034634	5/16-18 x 0.625 Fling Hex Bolt	6
18	5034660	3/8-16 x 0.75 Fling Hex Bolt	2

Assembly Procedure

Step 1

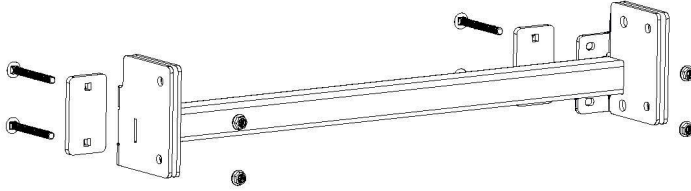

- Make sure the contents of the sprayer's carton match the items shown on page 4 of the manual.
- Follow the steps on pages 5, 6 & 7 to properly assemble the sprayer.

Step 1:

Mount the ZT Front Mount to your zero-turn mower, using the (4) Carriage Bolts, (2) Mount Plates, and (4) Serrated Flng Hex Nuts.

Step 2:

After removing the tank preassembly from the box, start the assembly procedure by turning the tank upside down on a stable, flat surface.

A PH screwdriver is required for this step.

(**) Mount the Tank Mount to the underside of the tank as shown in Step 2. Using (4) Flng Hex Bolts to secure it to the tank. Do not over-tighten.

The unit can now be turned over for the remaining steps.

Step 3:

Insert a Clevis Pin into the top hole of the Front mount and secure with a Cotter Pin, as show in figure A below. Repeat for other side.

Now the pre-assembled sprayer and tank mount, from step 2, can now be mounted to the Front Mount. Slide the completed unit, utilizing the slots on the Tank Mount over the Clevis Pins and drop down, so that the slot is now resting on the Clevis Pins, as show in figure B below.

Insert the remaining Clevis Pin through the holes, after lining the holes up and secure with the Hair Pin, as shown in figure C below.

To remove, just reverse the process, by removing the Hair Pin, then remove the Clevis Pin on the lower holes. Then lift up and pull the Front Mount out of the slots.

Step 2

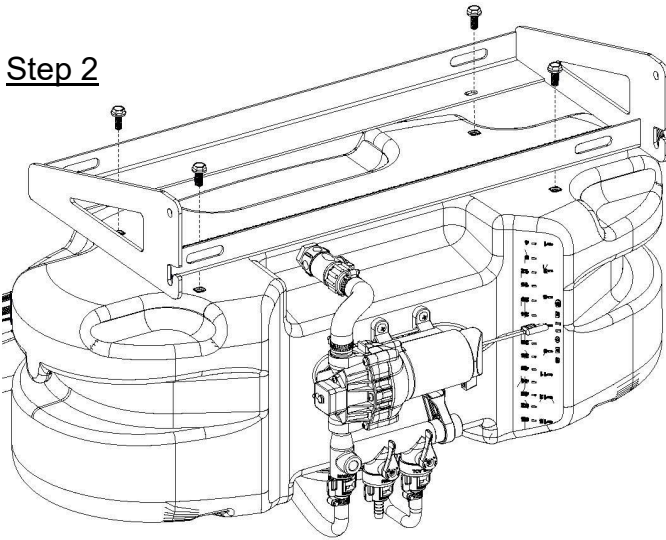

Step 3

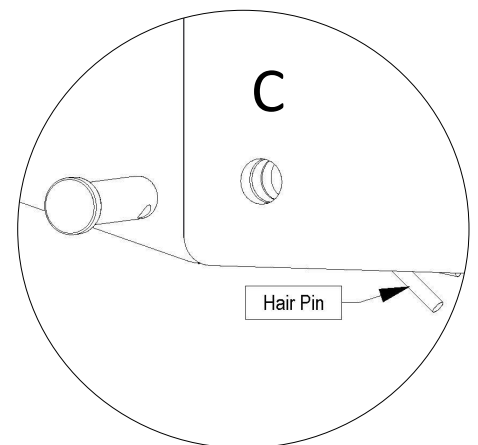
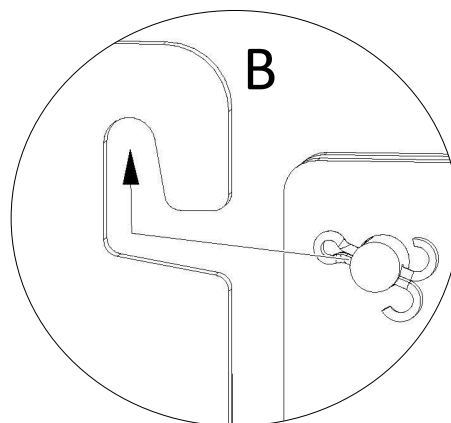
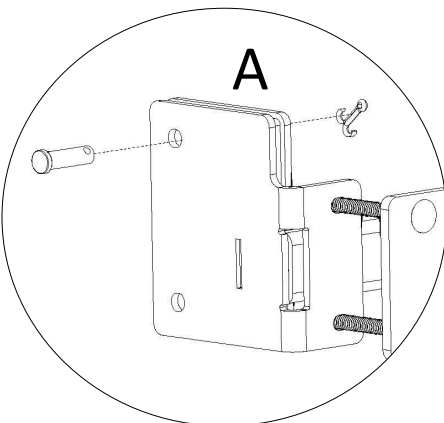
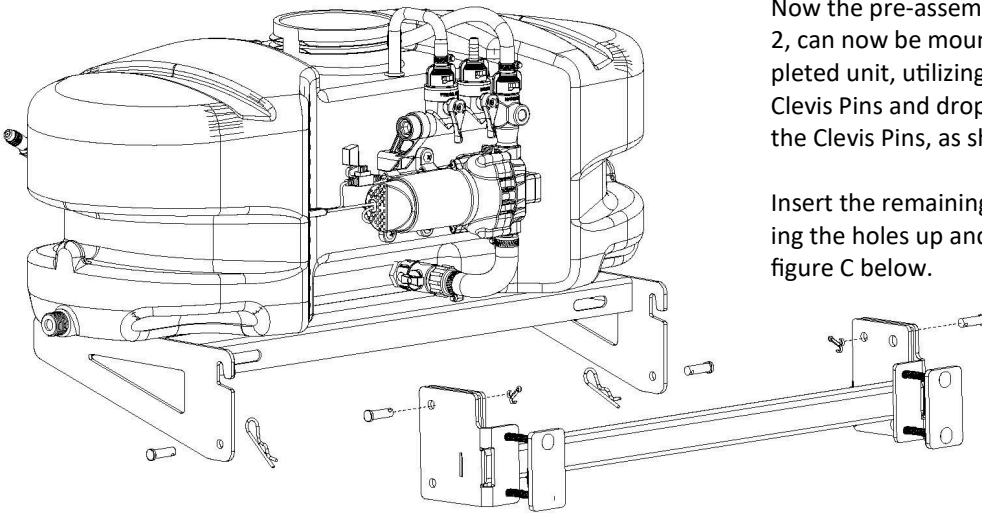

Assembly Procedure

Step 4

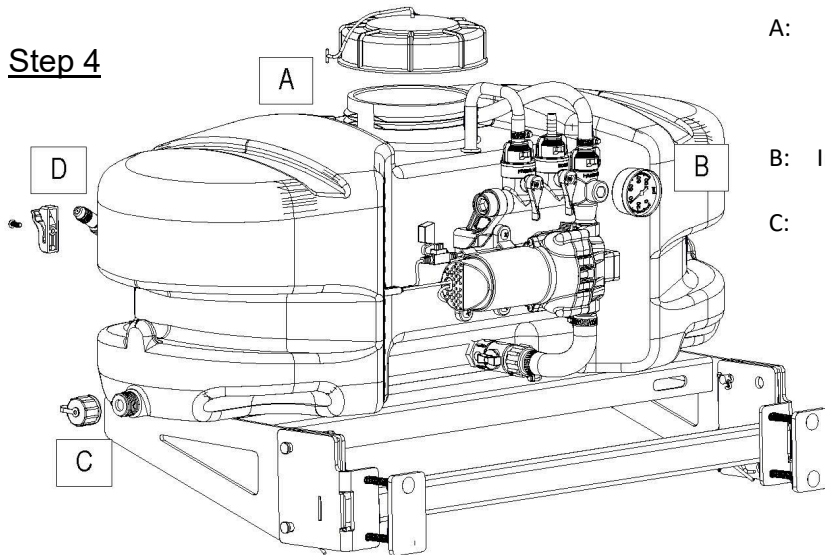

- A: Screw the lid onto the tank. Place the end of the lanyard through the tab in the tank. This is so the lid can 'hang' off the tank when filling/rinsing the tank out.
- B: Install the pressure gauge. Hand tighten securely.
**** DO NOT OVER-TIGHTEN ****
- C: If not already attached, thread the drain plug assembly onto the tank.
D: Locate the (2) clips and (2) Phillips head screws from the parts bag.
A PH screwdriver is required for this step
Place a screw through the hole in the clip and bring it up to the tank, where the embossments for the clips are.
Secure the clip/screw to the tank. Tighten securely.
Do this for each clip.
**** DO NOT OVER-TIGHTEN ****

The spray wand will snap into the clips once installed. Do not use excessive force when placing the spray wand into the clips, as this could cause the clips to break

Step 5

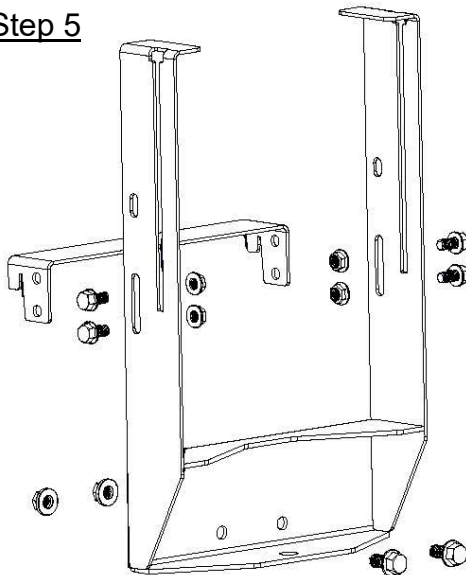

Step 5:

Attach the Boom Top Support to the Boom Mount, using (4) Fling Hex Bolts, and (4) Fling Hex Nuts. Then mount the assembled Boom Mount Bracket onto the rear of your zero-turn mower using the slots from the Boom Top Support, and then (2) Fling Hex Bolts, and (4) Serrated Fling Hex Nuts..

Step 6

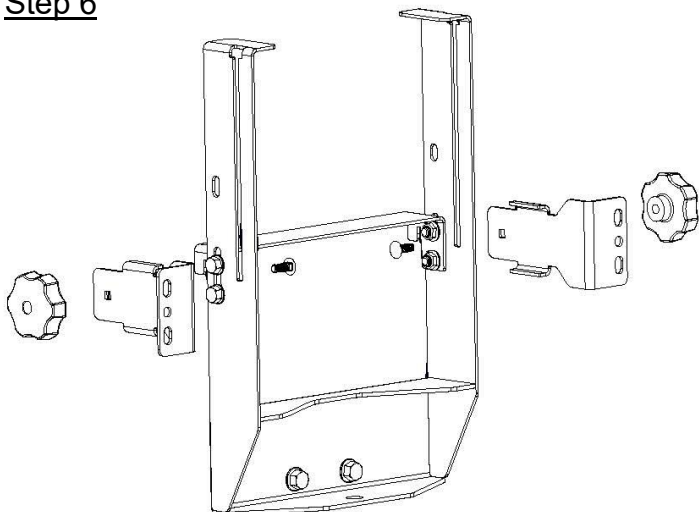

Step 6:

Attach the ZT Boom Mount on one side of the Boom Mount Bracket using (1) Lobe Knob and (1) Carriage Bolt, do not tighten, allow it to rest on the bottom of the slot and repeat for other side, tighten just enough to hold in place, as this will help in the following steps of attaching the boom, by keeping it level across the frame.

Assembly Procedure

Step 7

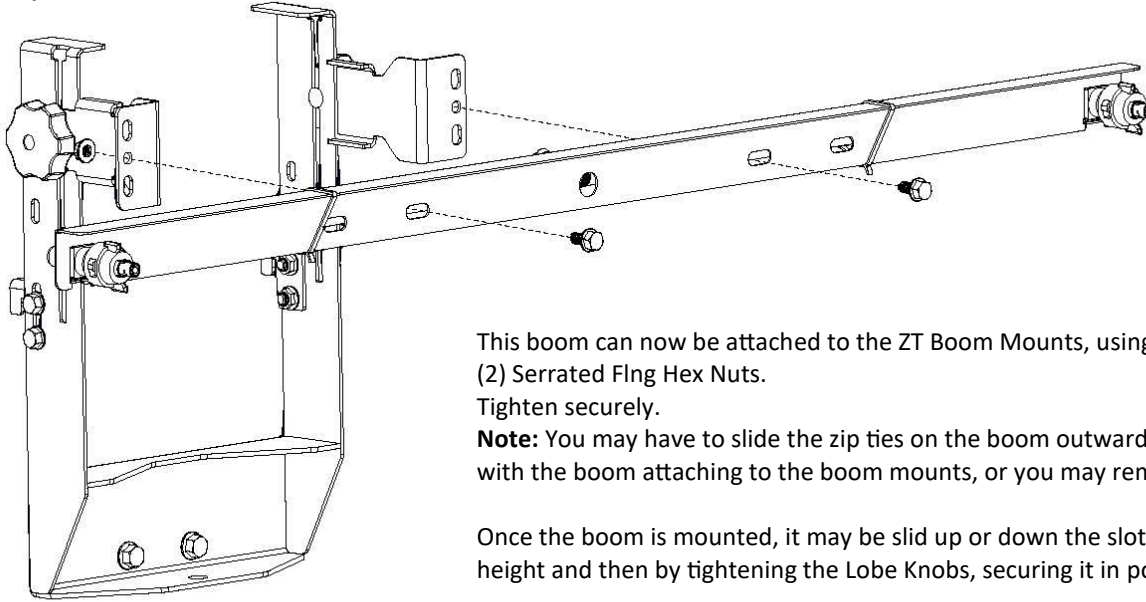

This boom can now be attached to the ZT Boom Mounts, using (2) Flng Hex Bolts and (2) Serrated Flng Hex Nuts.

Tighten securely.

Note: You may have to slide the zip ties on the boom outward, as to not interfere with the boom attaching to the boom mounts, or you may remove the zip ties.

Once the boom is mounted, it may be slid up or down the slot to the desired spray height and then by tightening the Lobe Knobs, securing it in position.

Try to maintain approximately 18—20 inches above the items being sprayed, 39" for optimal coverage.

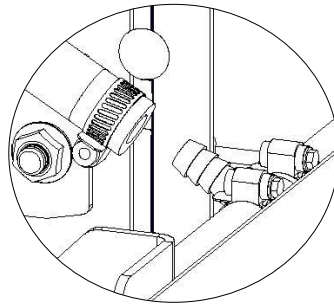
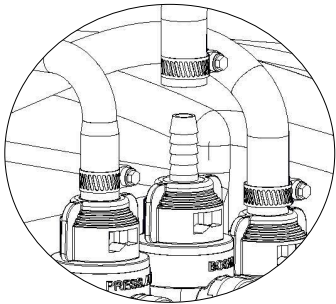

After your boom is attached to the boom mounts, locate the 124" feeder hose and the (2) hose clamps from the parts bag.

Place the hose clamps over each end of the hose loosely. Slip the ends of the hose over the hose barbs on both the manifold and the 'Tee' fitting on the nozzle harness. Use a twisting motion, if necessary, to get the hose fully onto each barb. Bring the hose clamps to the connection point and tighten securely.

- Make sure all hose clamps are tight before testing or spraying for the first time.
- One requirement will be to hook up the battery leads to a fully charged 12 Volt battery.
- The drain plug assembly should already be attached to the tank.

****The Sprayer is now ready to TEST w/plain water before actual use****

IMPORTANT: Remove tank lid and be sure the tank is clean and free of any foreign material. Rinse tank out of any tank residue before filling with water to test.

Testing the Sprayer

NOTE:

It is VERY important to test this sprayer with plain water before actual spraying is attempted. This will enable you to check the sprayer for leaks without the possibility of losing any expensive chemicals.

Fill the tank about 1/2 full with plain water and drive to the starting place for spraying.

When you are ready to spray, turn the boom valve to the “on” position (Detail A). This will start solution spraying from the tips of the boom. The pressure will decrease slightly when the boom is spraying.

Adjust the pressure by turning the “ON/OFF” valve lever on the Press. Adj. (bypass) valve (Detail B). Make sure your pattern is sufficient. You may down-pressure the system by ‘bypassing’ solution back into the tank. This is achieved by opening the Press. Adj. (bypass) valve. Regulating pressure is done in this manner.

Read the operating instructions and initially begin spraying by closing the ‘Pressure Adjust’ valve and opening the boom line valve (Detail A). This will enable the air in the line to be eliminated (purged) through all the tips, while building pressure. When everything tests all right (no leaks and good pressure), add the desired chemicals to the mixture and water combination and start your spraying operation. Adjust the pressure and spray as you did in the testing procedure.

Conditions of weather and terrain must be considered when setting the sprayer. Do not spray on windy days. Protective clothing must be worn in some cases.

Be sure to read the chemical label(s) before application!

Operation

The pumping system draws solution from the tank, through the strainer and to the pump. The pump forces the solution under pressure to the handgun or boom nozzles.

Fill the tank part way with water and then add the desired amount of chemical to be sprayed. Finish filling tank to proper level.

Only fill the tank with what you’re going to spray in a day, never leave chemicals sit in tank.

Connect the lead wire to a fully charged 12 volt battery. You may use either a stand-alone battery or the battery on your towing vehicle. Connect to the positive (red) terminal first, then connect to the negative (black) terminal. Then connect the end of the lead wire to the end of the pump. When disconnecting, disconnect the end of the pump wire from the lead wire, then disconnect the negative (black) connection and finally the positive (red) connection. Lead wire has an On/Off switch to activate the pump. “-” is on and “O” is off.

Turn the pump on by depressing the “-” side of the rocker switch. The pump is equipped with a pressure switch that is pre-set at the factory to shut the pump off when all discharges are closed.

The pump will turn back on when one of the following actions occurs:

- ◆ Handgun lever is squeezed to spray the handgun.
- ◆ Boom valve is opened to broadcast spray with the boom.
- ◆ Bypass valve is opened to re-circulate solution back into the tank.

When spraying with either the boom or the handgun, pressure may be reduced by slowly opening the Press. Adj. (bypass) valve until desired pressure is achieved. Opening the valve decreases pressure, closing the valve increases pressure. When spraying with the boom, the proper method to set the pressure is to open the boom valve completely and if a lower pressure is desired, then slowly open the bypass valve until that pressure is obtained.

For the safest and most efficient chemical application, you will need to calibrate your sprayer using the tip and speed charts. Once you have determined the proper speed and pressure settings, you will need to consult your chemical label for the amount of chemical to be added to the tank. Read the entire label. Use only according to label directions.

Manifold Valves CLOSED

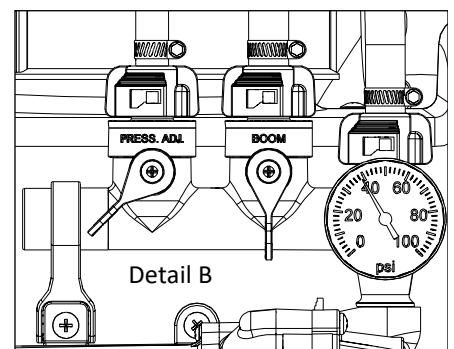
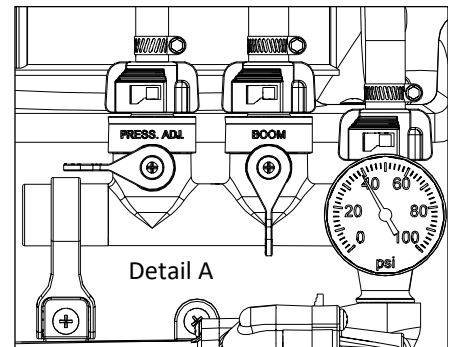
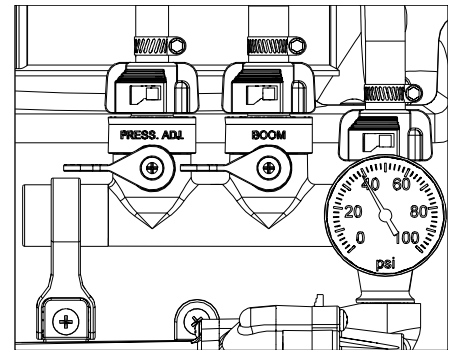

Calibration

Chemical labels may show application rates in gallons per acre, gallons per 1000 square feet or gallons per 100 square feet. You will note that the tip chart shows 3 of these rating systems. Once you know how much you are going to spray, then determine (from the tip chart) the spraying pressure (PSI), and the spraying speed (MPH).

Determining the proper speed of the pulling vehicle can be done by marking off 100, 200 & 300 feet. The speed chart indicates the number of seconds it takes to travel the distances. Set the throttle and with a running start, travel the distances. Adjust the throttle until you travel the distances in the number of seconds indicated by the speed chart. Once you have reached the throttle setting needed, mark the throttle location so you can stop and go again, returning to the same speed.

Add water and proper amount of chemical to the tank and drive to the starting place for spraying.

Speed Chart			
Speed in M.P.H. (Miles Per Hour)	Time Required in seconds to travel a distance of		
	100 Ft.	200 Ft.	300 Ft.
1.0	68 sec.	136	205
2.0	34	68	102
3.0	23	45	68
4.0	17	34	51
5.0	14	27	41
6.0	11	23	34
7.0	9.7	19	29
8.0	8.5	17	26
9.0	7.6	15	23
10.0	6.8	14	20

Tip Chart for TKT-VP3, TF-VP3 & 30DT3.0 (Gray) Tips									
	Pressure (psi)	Capacity (GPM)	1 MPH	2 MPH	3 MPH	4 MPH	5 MPH	7.5 MPH	10 MPH
Gallons Per Acre Based on Water	10	.30	44	22	14.9	11.1	8.9	5.9	4.5
	20	.42	63	31.5	20.9	15.7	12.6	8.4	6.3
	30	.52	76	38	26	19.3	15.4	10.3	7.7
	40	.60	90	45	30	22	17.8	11.8	8.9
Gallons Per 1000 Sq. Ft. Based on Water	10	.30	1.01	.5	.34	.254	.204	.135	.103
	20	.42	1.4	.72	.48	.36	.29	.19	.14
	30	.52	1.74	.87	.596	.44	.35	.236	.176
	40	.60	2.06	1.00	.688	.50	.408	.27	.20
Gallons Per 100 Sq. Ft. Based on Water	10	.30	.10	.05	.034	.025	.02	.013	.01
	20	.42	.14	.072	.048	.036	.029	.019	.014
	30	.52	.174	.087	.059	.044	.035	.023	.017
	40	.60	.206	.10	.068	.05	.04	.027	.02

Using the Boom Nozzles

Four things must be considered before spraying with the boom.

1. How much chemical must be mixed.
 2. Rate of spray (gallons per acre to be sprayed).
 3. What pressure (p.s.i.) will be used.
 4. Speed traveled (mph) while spraying.
- * Refer to the chemical label to determine your chemical mixture
 - * See the tip chart to determine the pressure to be used. The chart will also show the speed used when spraying.
 - * Start the pump and open the valve to the boom nozzles.
 - * Check the spray pattern. Usually you can see the coverage better on a solid concrete surface, such as a driveway.

Maintenance During/After Spraying

Periodically check the strainer and clean the screen on your intake line.

If sprayer becomes clogged during use, discontinue use immediately. DO NOT attempt to service while chemicals are in the sprayer and power is connected.

Proper care and maintenance will prolong the life of your sprayer.

After use, drain the tank and store or dispose of chemical properly. Fill the sprayer half way with clean water. Start the pump and allow the water to pump through the entire plumbing system and nozzles. Drain and then refill half full, add the recommended amount of a good quality tank cleaner, such as FIMCO Tank Neutralizer and Cleaner. (If no tank cleaner is available, you may substitute dish soap for this step, about 1-2 oz. per gallon). But a neutralizer/cleaner should be used to thoroughly clean the system. Turn pump on and circulate through system for 15 minutes and then spray out through boom and handgun nozzles. Refill sprayer half way with clean water and repeat. Follow the chemical manufacturer's disposal instructions of all wash or rinsing water.

If boom or handgun nozzles need cleaning, remove them from the sprayer and soak in warm soapy water. Clean with a soft bristled brush or toothpick if necessary. Never use a metal object. Even the slightest damage can change the flow rate and spray distribution. Water rinse and dry the tips before storing.

WARNING: Some chemicals will damage the pump valves if allowed to soak untreated for a length of time! ALWAYS flush the pump as instructed after each use. DO NOT allow chemicals to sit in the pump for extended times of idleness. Follow the chemical manufacturer's instructions on disposal of all waste water from the sprayer.

Tank Care & Maintenance

Warning: Do not use the tank as a container for fuel oils, kerosene, gasoline or any other petroleum distillate product. All polyolefins are softened and permeated by such products. In an enclosed area the vaporization of these materials from the outside surface of the tank could create a dangerous condition.

The tank should not be used as a pressure vessel nor used with chemicals or solutions having a weight of more than 12 pounds per gallon.

Store the tank in a dry dark place when not in use. Storage out of sunlight will prolong the life of the tank.

Do not drop, strike or kick the tank, especially at low temperatures. Tanks become brittle and are subject to cracking at temperatures below 20° Fahrenheit.

Always flush the tank with water and a neutralizing agent at the end of each use, to prevent contamination of solutions.

Winter Storage

Prepare the sprayer for end-of-season storage by running RV antifreeze through the system. This will keep internal parts lubricated, protect against corrosion and keep the unit from freezing. *Note: RV antifreeze is non-toxic and biodegradable and generally safer for the environment than automotive antifreeze.*

Before storing your sprayer for winter or long term storage, thoroughly clean and drain it as much as possible. Then pour enough pink RV antifreeze into the tank so that when the pump is turned on you can pump the antifreeze throughout the entire plumbing system, including the bypass. Make sure to operate the boom and handgun until you see pink fluid spraying from the nozzles. Leave any remaining antifreeze in the tank. Before your next usage, rinse the antifreeze from the sprayer with clean water.

It is nearly impossible to drain all of the water from the sprayer and any trapped water can freeze in cold weather and damage parts of the sprayer. Pumping the antifreeze through the system will displace the water and help prevent this damage.

Removing from storage: drain the antifreeze. Fill the tank with fresh water and run through the system. Dispose of antifreeze and flush water properly.

Intake/Siphon Tube/Screen Detail of a Typical L&G/ATV Sprayer (not including the 'EC' Units)

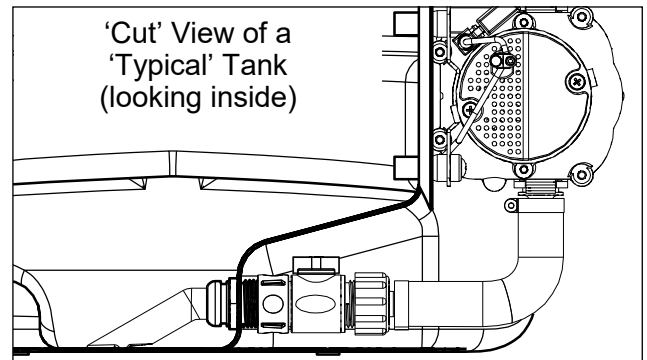
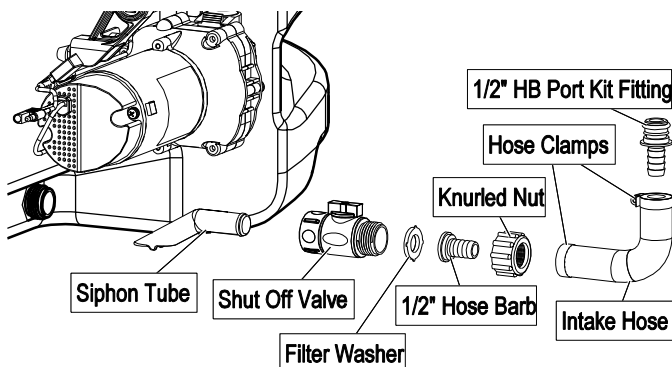

The suction line of your sprayer should contain a 'siphon tube' or intake tube which should be rotated so that it just touches the bottom of the tank surface. (see Detail Views). Reach in and rotate it, as needed, if not already in this position.

A shut-off valve is threaded onto the pipe nipple at the intake location on the tank. It is at this location so you can shut off the flow of solution to access your system's screen for cleaning.

Checking/Cleaning the sprayer's filter/screen:

- ◆ Start your pump and before it shuts off, reach down and shut the valve to the 'Closed' position (lever is perpendicular to the flow of fluid), then shut off your pump.
- ◆ Unscrew the knurled nut from the shut-off valve, leaving the valve connected to the tank.
- ◆ Swing (swivel) the intake assembly towards you. Look in the nut you JUST unscrewed. There is a screen/washer located there.
- ◆ Remove the screen and clean as necessary. Replace when done and reassemble the entire assembly.
- ◆ Make sure the valve is turned to the 'Open' position before restarting your pump.

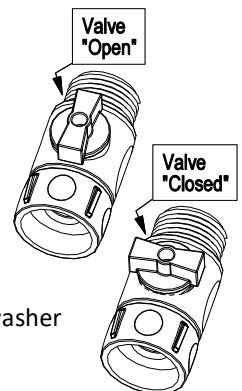

Exploded View & Parts List

CAUTION
PRESSURE SWITCH OPERATION
 Pressure switch is pre-set at the factory. Improper adjustment of the pressure switch, may cause severe overload or premature failure. If the pump is subjected to rapid cycling during normal operation, or infrequent periods, damage may occur.

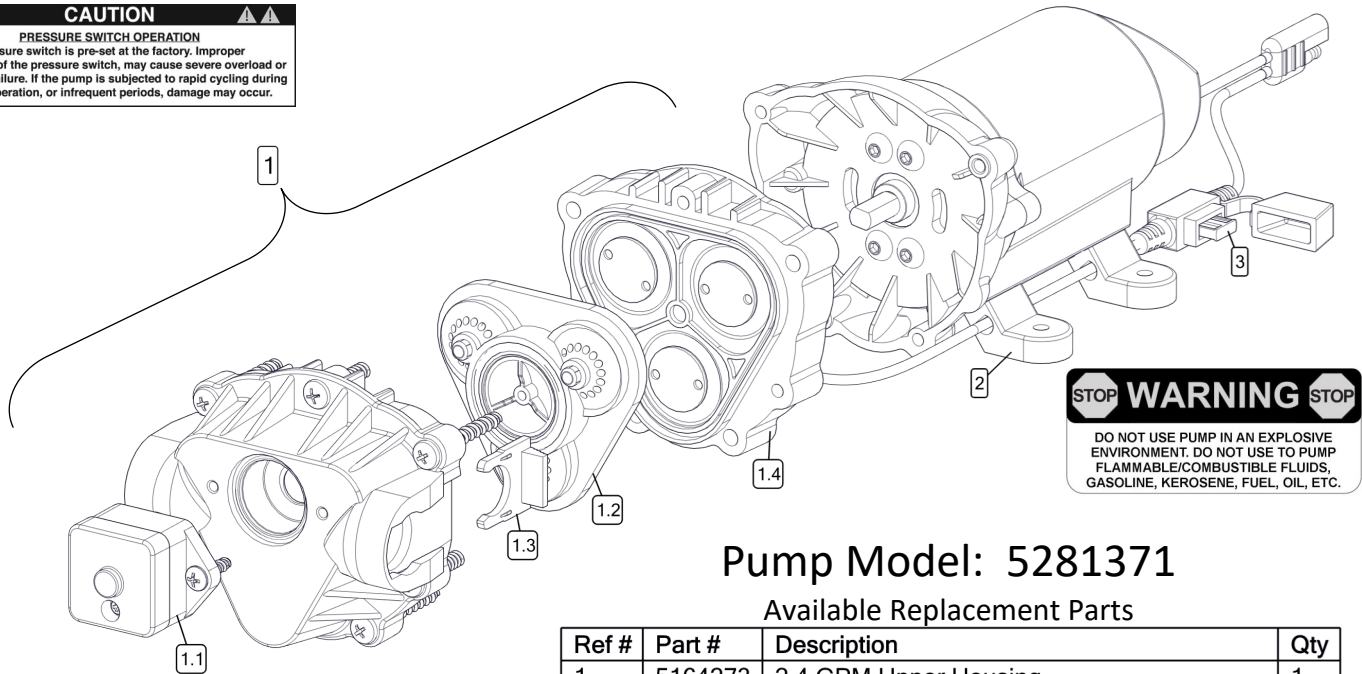

STOP WARNING STOP
 DO NOT USE PUMP IN AN EXPLOSIVE ENVIRONMENT. DO NOT USE TO PUMP FLAMMABLE/COMBUSTIBLE FLUIDS, GASOLINE, KEROSENE, FUEL, OIL, ETC.

Pump Model: 5281371

Available Replacement Parts

Ref #	Part #	Description	Qty
1	5164273	2.4 GPM Upper Housing	1
1.1	5157202	60 PSI Pressure Switch Assembly	1
1.2	5143544	Check Valve Assembly	1
1.3	5051162	Pump Slide Clips (Pkg/2)	1
1.4	5063270	2.4 GPM Diaphragm /Piston/Cam/Bearing Kit	1
2	5095202	Pump Mount Feet (4 Pack)	1
3	5164274	10 Amp 'Mini Blade' Fuse	1

Replacement Pump: 5151087

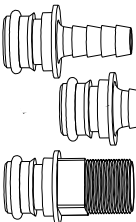

Includes:

3/8" Hose Barb Port Kit Fitting #5168836

1/2" Hose Barb Port Kit Fitting #5168833

1/2" MNPT Port Kit Fitting #5168832



- Clean and rinse your pump after each use with Fimco Tank Neutralizer.
- Winterize your pump or sprayer by rinsing, draining and running RV Antifreeze through it before storing for the winter.
- Use clean water for your spray mixture.
- Store inside a building when not in use.



- Use to pump bleach.
- Use to pump petroleum products such as diesel fuel, gasoline or kerosene.
- Use to pump chemicals w/petroleum distillates or surfactants.
- Use to store flammable or combustible liquids.
- Leave your pump sit with spray mixture in it for extended periods.
- Use dirty or unfiltered water for spraying.

Before Troubleshooting or Attempting to Service the Pump:

- ◆ **Review Troubleshooting Chart:** Do Not attempt to repair until steps below are followed.
- ◆ **Personal Protective Gear:** Wear protective gear when servicing pump.
- ◆ **Disconnect Power:** Disconnect the power to the pump and relieve the pressure from the system.
- ◆ **Empty and Flush** the pump system with water, never attempt to service the pump until it has been emptied and flushed.
- ◆ **Perform Repairs:** Follow directions provided in the troubleshooting section to repair the pump.
- ◆ **Test:** Always test the pump for leaks with plain water after any repairs before using.

Troubleshooting

Motor is NOT Running - Checking the Pressure Switch:

If motor is not running and you've checked the following: for loose wiring connections, fuse, switch on lead wire was "ON" and made sure you were connected to a fully charged battery but the motor won't run, then it's time to check to see if the pressure switch is bad.

- Remove the cover off the 1" square box (pressure switch) on the head of the pump, the cover is held on by one phillips-head screw. This will expose the two red wires.
 - With the pump connected to a good 12 volt power source and everything on.
 - Slip the two red wires off the terminals and touch them together.
- ◆ If motor runs, it means the pressure switch is bad and needs to be replaced.
 - ◆ If motor still doesn't run, try bypassing the switch in the lead wire or using another lead wire. Even if a tester shows power to the pressure switch, still try this test.

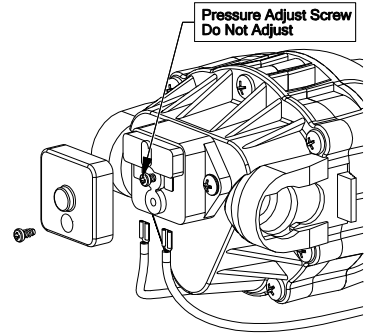

Warning: It is NOT recommended to run the pump this way, as the pump will continue to run and not shut off.

This could result in blown hoses when all discharges are closed or premature failure of the pump completely.

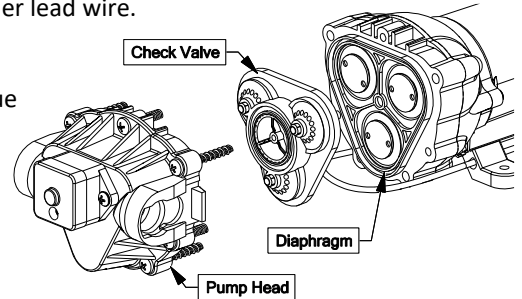

Motor Running-No Pressure - - Cleaning the Check Valve:

Experiencing little to no pressure or pump is not priming and filter screen is clean and plumbing is good with no leaks, you may need to clean the check valve.

- Remove the head of the pump, which is held on by 7 screws.
- First part inside the head of the pump is the check valve, this part responsible for building up pressure and pumping water/solution through the lines.
- Clean the check valve under hot, soapy water (such as a good grade dish soap).
- Lightly scrub, if needed, with something like an old toothbrush, something with soft bristles.
- Let soak for about an hour or so in the hot soapy solution, replace in the pump and reassemble.

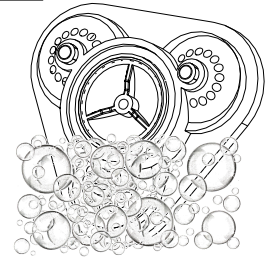

Most times this will restore most, if not all of the prime of a pump.

If still having issues with pressure after this step, it would be recommended to replace this part.

Troubleshooting	
Pump will not run:	Check for loose wiring
	Make sure the ON/OFF switch is on
	Check the fuse
	Check for defective pressure switch
	Check to see if connected to good 12 Volt Power Source
	Check for Low Voltage
Pump Does Not Prime (No Discharge w/Motor Running)	Check for clogged strainer/filter
	Check for kinked inlet/outlet hoses
	Check for empty product supply
	Check for defective check valve
	Check for debris in the check valve assembly
	Check for cracks in the pump housing
Low Pressure/ Low Flow:	Check for air leaks in supply line
	Check for a clogged strainer
	Check for proper voltage Try another 12-Volt battery
	Check for leaks in the discharge line
	Check for restrictions in the discharge line
	Check for debris in intake
Pump surges:	Check for debris in nozzle orifice
	Check for worn or dirty check valve
	Discharge hose may be too long
	Check for clogged strainer/filter
	Check for worn or dirty check valve
	Slightly open bypass (if applicable) to overcome
Pump continues to run:	Pressure switch may need to be adjusted 1/4 turn at a time clockwise until surging stops
	Check for worn or dirty check valve
	Check for empty product supply
	Check for Low Voltage
	Check for leaks in the discharge line
	Check for defective pressure switch
Fuse blows:	System has leaks
	Air trapped in outlet line or pump head
	Excessive voltage
	Improper adjustment of pressure switch
	Damaged or defective wiring harness
	Defective pressure switch

Pump FAQs

Sprayer and Pump FAQs:

◆ **Why does the pump not run all the time?**

This is an on-demand pump and only runs when a discharge is open (spray gun, bypass, boom (if applicable) or a leak in system).

◆ **Why does the pump surge while using the spray gun?**

Low flow/high pressure may cause the pump to surge (or cycle). Typically the spray wand is adjusted at too fine of a mist, to overcome, adjust the nozzle for a higher flow.

◆ **How do I adjust the pressure?**

Pressure can only be adjusted by opening the pressure adjust (bypass) valve to allow some of your water or solution to return to the tank (if equipped).

◆ **Pump quit and will not run, what do I need to do?**

Squeeze trigger on spray gun to ensure that the system isn't just pressurized up with discharges closed.

Check electrical connections, ensure switch is on. Check fuses. Check for proper voltage. Check pressure switch.

◆ **Low flow or no flow at all, what do I need to check for?**

Check for a clogged or kinked intake hose and/or clogged intake strainer. Check for proper voltage.

You will need to occasionally check your intake strainer to ensure that it is clean of any debris.

◆ **What is causing the fuse to blow each time I turn the pump on?**

Check for excessive voltage. Improper adjustment of the pressure switch. Damaged or defective wire harness or defective pressure switch.

Warning:

Ensure the wiring harness does not become pinched or damaged in any way. This may damage the pump or cause the wiring harness to overheat, resulting in a melt down or fire.

Intended Uses:

The pump is intended to be used spraying agricultural pesticides, herbicides, and other non-flammable liquids.

Spraying Pesticides:

Pesticides are hazardous chemicals that must be handled with caution as directed on the pesticide label. Pesticides are regulated by the United States Environmental Protection Agency (EPA) and defined as:

Any substance or mixture of substances intended for preventing, destroying, repelling, or mitigating any pest. Though often misunderstood to refer only to insecticides, the term pesticides is a comprehensive term that applies to insecticides, herbicides, fungicides, and various other substances used to control pests.

The pump is intended for use in spraying pesticides in liquid form only. The pump is NOT intended for use in spraying pesticides in dry or aerosolized form, for use with fumigants.

In addition to spraying pesticides, this pump may be used to spray other **non-flammable** liquids. Example uses include herbicides, watering plants/trees or spraying water for dust control, or applying water-based, **non-flammable** sealant or stain to outdoor wood surfaces.

WE RECOMMEND THAT THE PUMP NOT BE USED FOR OTHER PURPOSES ONCE IT HAS ALREADY BEEN USED FOR SPRAYING PESTICIDES.

Any chemical will leave some residual in the pump components, even after the pump has been properly cleaned. These residual chemicals can have unexpected effects on future uses. For example, spraying water or other liquids that are contaminated with residual pesticide may result in unforeseen hazards to plant or animal life.

NOTE: The pump will be damaged, and warranty voided if used to apply bleach, chlorine, ice control chemicals, or any petroleum-based product (gasoline, diesel, kerosene, oil).

Exploded View: ZTM-15-2N-BBA (5303870)

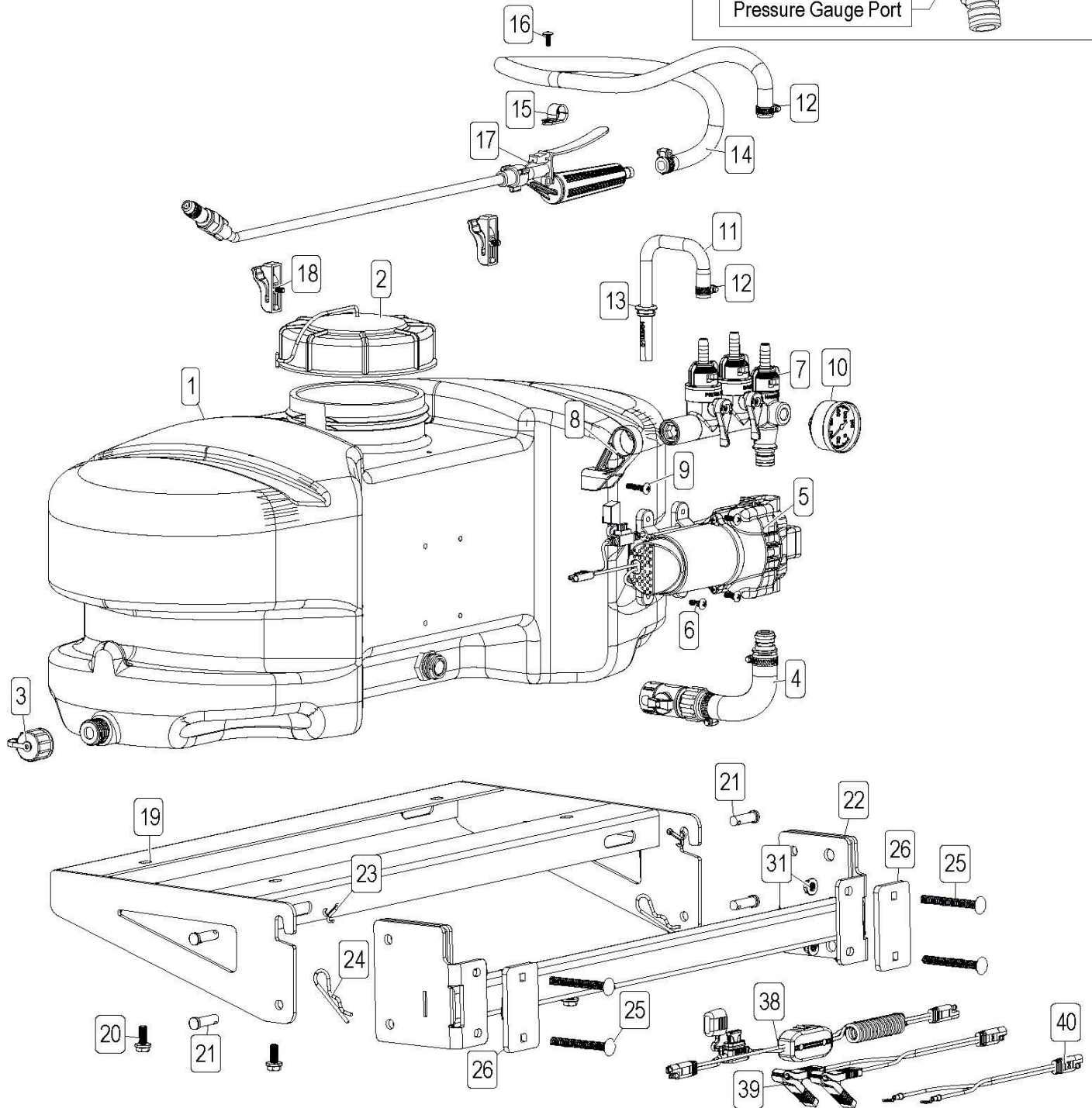
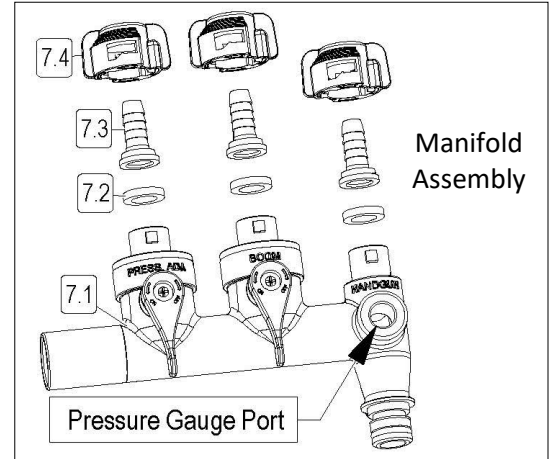
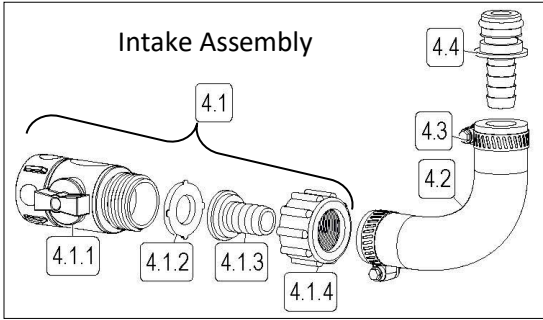

Exploded View: ZTM-15-2N-BBA (5303870)

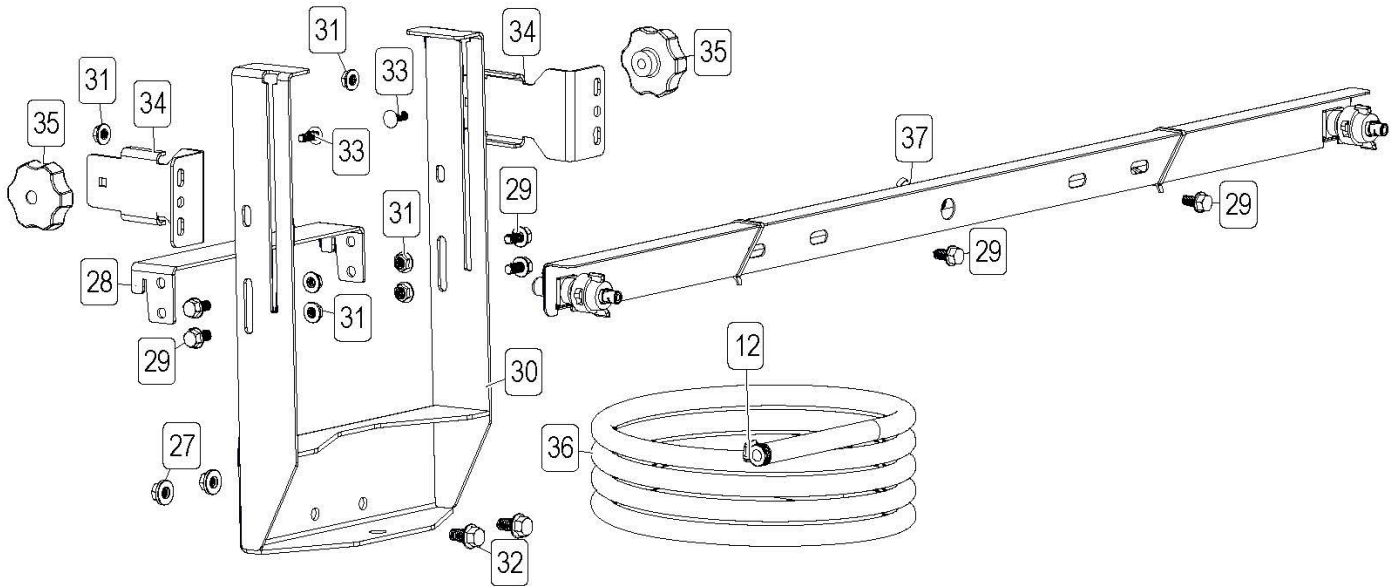

Parts List: ZTM-15-2N-BBA (5303870)

Ref. #	Part #	Description	Qty
1	5169242	15-Gallon Tank	1
1.1	5100452	Siphon Tube	1
2	5058188	Tank Lid w/Lanyard	1
3	5274373	Drain Plug Assembly	1
4	5281145	4 1/4" Long Intake Shut-Off Assembly	1
4.1	5282416	Intake Shutoff Subassembly	1
4.1.1	5143419	Swivel Shut-Off	1
4.1.2	5116242	Strainer, 1" Filter Washer	1
4.1.3	5149035	Poly Swivel, 1/2" Hose Barb	1
4.1.4	5006209	Poly Knurled Swivel Nut, 3/4" FGHT	1
4.2	5020583	1/2" Polyspring Hose x 4 1/4" Long	1
4.3	5051114	Hose Clamp (1/2")	2
4.4	5168833	1/2" Hose Barb Port Fitting	1
5	5281371	2.4 GPM Pump, 60 PSI	1
6	5117167	#10-24 x 0.625 PH Truss Head Screw	3
7	5281538	Quick Connect Manifold Assembly	1
7.1	5302347	Quick Connect Manifold (Main Body)	1
7.1.1	5072514	O-Ring -113	1
7.1.2	5143421	Quick Connect Manifold - Handle	2
7.2	5143430	Flat Washer - Hose Barb Seal	3
7.3	5143431	QC Manifold - 3/8" Hose Straight Barb	3
7.4	5143429	Quick Connect Quarter Turn Cap	3
8	5143422	Quick Connect Manifold - Support Bracket	1
9	5117168	#10-24 x 1.00 PH Truss Head Screw	1
10	5167097	2" Dry 100# Back Mount Gauge	1
11	5100964	Formed Bypass Tube	1
12	5051144	Hose Clamp (3/8")	5
13	5075018	Grommet	1
14	5020524	Hose, 3/8"-1 Brd. x 15 Ft.	1

Ref. #	Part #	Description	Qty
15	5051122	5/8" Black Nylon Loom Cable Clamp	1
16	5117234	#10-24 x 0.50 PH Truss Head Screw	1
17	5163100	Low-Flow Spray Wand w/X-26 Tip	1
17.1	5018330	Handgun Tip (X-26)	1
18	5274880	Wand Clips & Screws (Pkg/2)	1
19	5283385-BLK	15G ATV ZT Tank Mount	1
20	5117323	5/16-18 x 0.75 Fling Hex Bolt	4
21	5101277	Clevis Pin, 3/8 x 1.25	4
22	5283388-BLK	BB Mount Weldment	1
23	5101077	Cotter Pin, 1/8" x 1"	2
24	5101065	Hair Pin, #211 x 2.50	2
25	5034550	5/16-18 x 3.00 Carriage Bolt	4
26	5029257-BLK	Bad Boy Mount Plate	2
27	5006259	3/8-16 Serrated Fling Hex Nut	2
28	5070621-BLK	BB ZT Boom Top Support	1
29	5034634	5/16-18 x 0.625 Fling Hex Bolt	6
30	5283389-BLK	BB ZT Boom Mount	1
31	5006307	5/16-18 Serrated Fling Hex Nut	10
32	5034660	3/8-16 x 0.75 Fling Hex Bolt	2
33	5034481	1/4-20 x 0.75 Carriage Bolt	2
34	5070614-BLK	ZT Boom Mount	2
35	5088026	5 Lobe Knob 1/4-20UNC	2
36	5020968	Hose, 3/8" - 2 Brd. x 124"	1
37	5277774	2-Nozzle Rigid Trailer Boom (QJ)	1
38	5164336	60" 16AWG 15A Switched Lead Wire w/Fuse	1
38.1	5157238	15 Amp Regular Blade Fuse	1
39	5164333	36" 16AWG Battery Clamp Ends	1
40	5164334	36" 16AWG Ring Terminal Ends	1

Exploded View/Parts List: 2-Nozzle Boom Assembly (5277774)

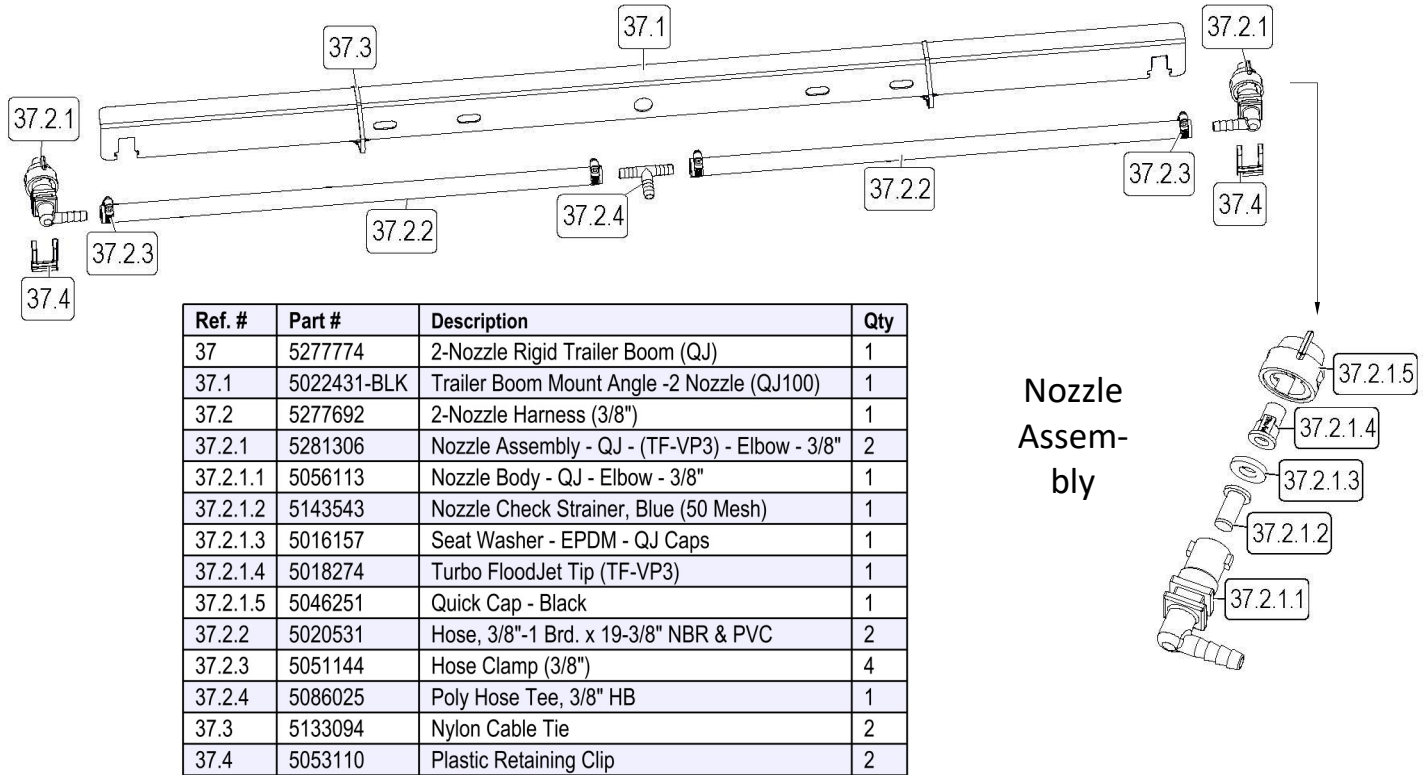

Based on the minimum overlap required to obtain uniform distribution with 120° tips and 40" spacing.

Suggested Minimum Spray Height: 18"-20" above what is being sprayed (to plant, not ground).

Optimum Spray Height: 39"

Wide angle spray nozzle height is influenced by nozzle orientation. The critical factor is to achieve a minimum 30% overlap.

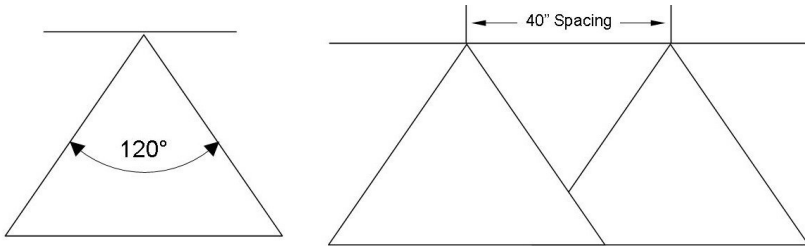

- Excellent spray distribution for uniform coverage along the boom.
- Nozzle design incorporates a pre-orifice to produce larger droplets for less drift.

Approx. Dimensions

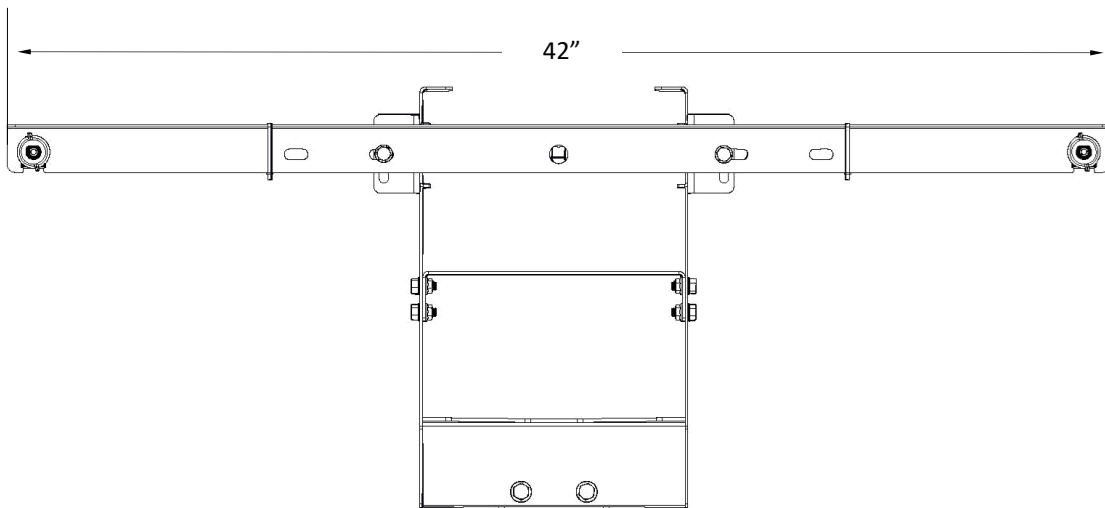
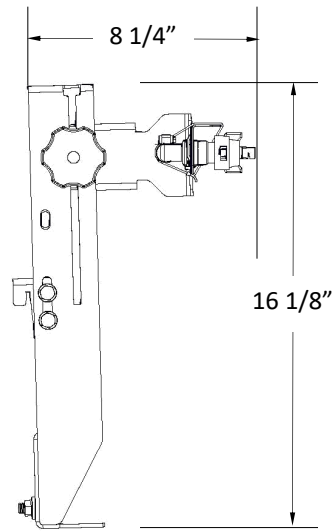
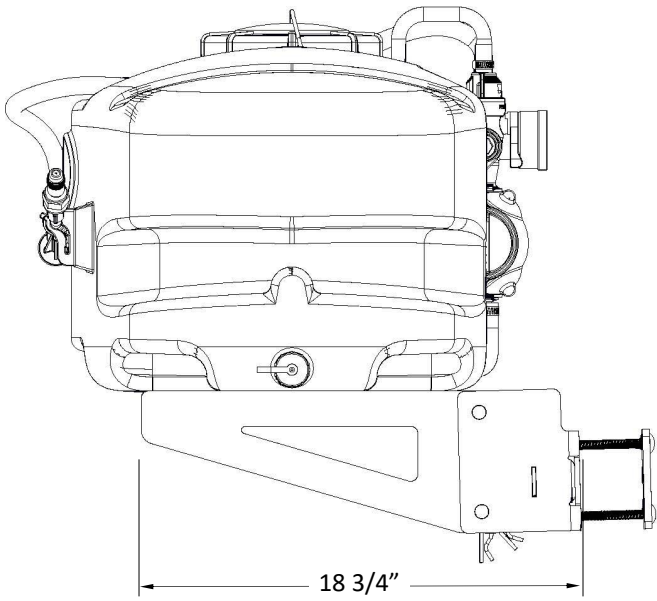
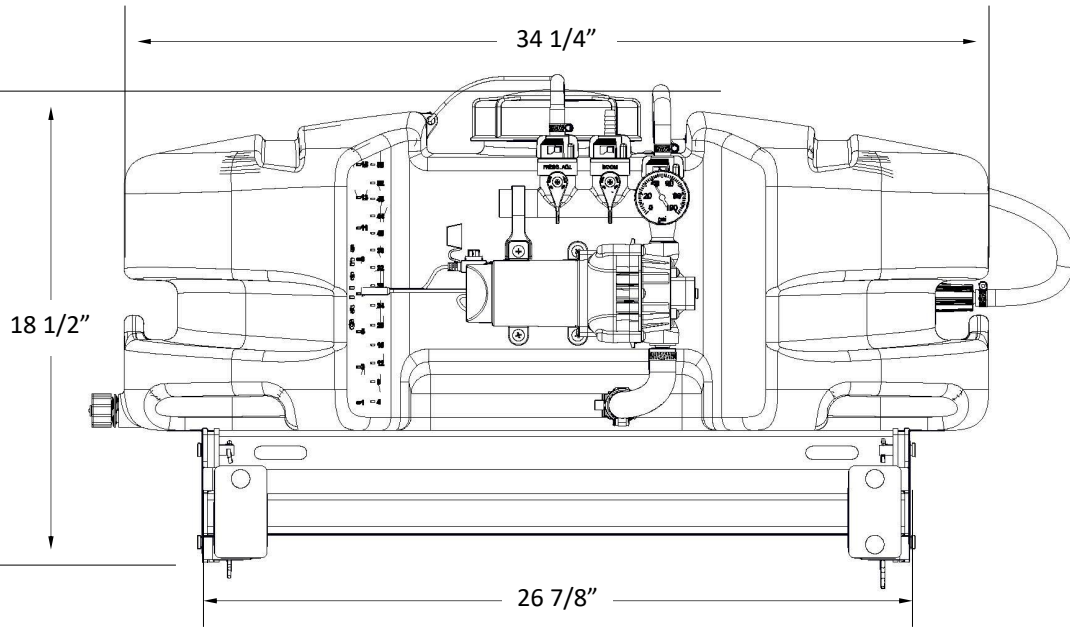

Notes:

Notes:

Warranty

LIMITED WARRANTY FOR NEW FIMCO, IND. EQUIPMENT

WHO MAY USE THIS LIMITED WARRANTY. This limited warranty (the "Limited Warranty") is provided by Fimco, Ind. to the original purchaser ("you") of the Equipment (as defined below) from Fimco, Ind. or one of Fimco, Ind.'s authorized dealers. This Limited Warranty does not apply to any subsequent owner or other transferee of the Equipment. THIS LIMITED WARRANTY GIVES YOU SPECIFIC LEGAL RIGHTS, AND YOU MAY ALSO HAVE OTHER RIGHTS WHICH VARY FROM STATE TO STATE.

WHAT THIS LIMITED WARRANTY COVERS AND FOR HOW LONG. Fimco, Ind. warrants that any new Equipment will be free from defects in material and workmanship for a period of **one (1) year** for sprayer and **two (2) years** for High-Flo High Performance pump (homeowner), **90 days** for sprayer and pump (commercial user), after delivery of the Equipment to you (the "Warranty Period"). The Warranty Period is not extended if Fimco, Ind. repairs or replaces the Equipment.

WHAT IS NOT COVERED BY THIS LIMITED WARRANTY. This Limited Warranty does not apply to: (1) used Equipment; (2) any Equipment that has been altered, changed, repaired or treated since its delivery to you, other than by Fimco, Ind. or its authorized dealers; (3) damage or depreciation due to normal wear and tear; (4) defects or damage due to failure to follow Fimco, Ind.'s operator's manual, specifications or other written instructions, or improper storage, operation, maintenance, application or installation of parts; (5) defects or damage due to misuse, accident or neglect, "acts of God" or other events beyond Fimco, Ind.'s reasonable control; (6) accessories, attachments, tools or parts that were not manufactured by Fimco, Ind., whether or not sold or operated with the Equipment; or (7) rubber parts, such as tires, hoses and grommets.

HOW TO OBTAIN WARRANTY SERVICE. To obtain warranty service under this Limited Warranty, you must (1) provide written notice to Fimco, Ind. of the defect during the Warranty Period and within **thirty (30) days** after the defect becomes apparent or the repair becomes necessary, at the following address: Fimco, Ind., 1000 Fimco Lane, North Sioux City, SD 57049; and (2) make the Equipment available to Fimco, Ind. or an authorized dealer within a reasonable period of time. For more information about this Limited Warranty, please call: **800-831-0027**.

WHAT REMEDIES ARE AVAILABLE UNDER THIS LIMITED WARRANTY. If the conditions set forth above are fulfilled and the Equipment or any part thereof is found to be defective, Fimco, Ind. shall, at its own cost, and at its option, either repair or replace the defective Equipment or part. Fimco, Ind. will pay for shipping and handling fees to return the repaired or replacement Equipment or part to you.

LIMITATION OF IMPLIED WARRANTIES AND OTHER REMEDIES. THE REMEDIES DESCRIBED ABOVE ARE YOUR SOLE AND EXCLUSIVE REMEDIES, AND FIMCO, IND.'S SOLE LIABILITY, FOR ANY BREACH OF THIS LIMITED WARRANTY. TO THE EXTENT APPLICABLE, ANY IMPLIED WARRANTIES, INCLUDING, WITHOUT LIMITATION, THE IMPLIED WARRANTIES OF MERCHANTABILITY AND FITNESS FOR A PARTICULAR PURPOSE, SHALL BE LIMITED IN DURATION TO THE WARRANTY PERIOD, AND THE REMEDIES AVAILABLE FOR BREACH THEREOF SHALL BE LIMITED TO THE REMEDIES AVAILABLE UNDER THIS EXPRESS LIMITED WARRANTY. SOME STATES DO NOT ALLOW LIMITATIONS ON HOW LONG AN IMPLIED WARRANTY LASTS, SO THE ABOVE LIMITATION MAY NOT APPLY TO YOU. IN NO EVENT SHALL FIMCO, IND.'S LIABILITY UNDER THIS LIMITED WARRANTY EXCEED THE ACTUAL AMOUNT PAID BY YOU FOR THE DEFECTIVE EQUIPMENT, NOR SHALL FIMCO, IND. BE LIABLE, UNDER ANY CIRCUMSTANCES, FOR ANY CONSEQUENTIAL, INCIDENTAL, SPECIAL OR PUNITIVE DAMAGES OR LOSSES, WHETHER DIRECT OR INDIRECT. SOME STATES DO NOT ALLOW THE EXCLUSION OR LIMITATION OF INCIDENTAL OR CONSEQUENTIAL DAMAGES, SO THE ABOVE LIMITATION OR EXCLUSION MAY NOT APPLY TO YOU.