

PATIO CHAIR

ASSEMBLY INSTRUCTION

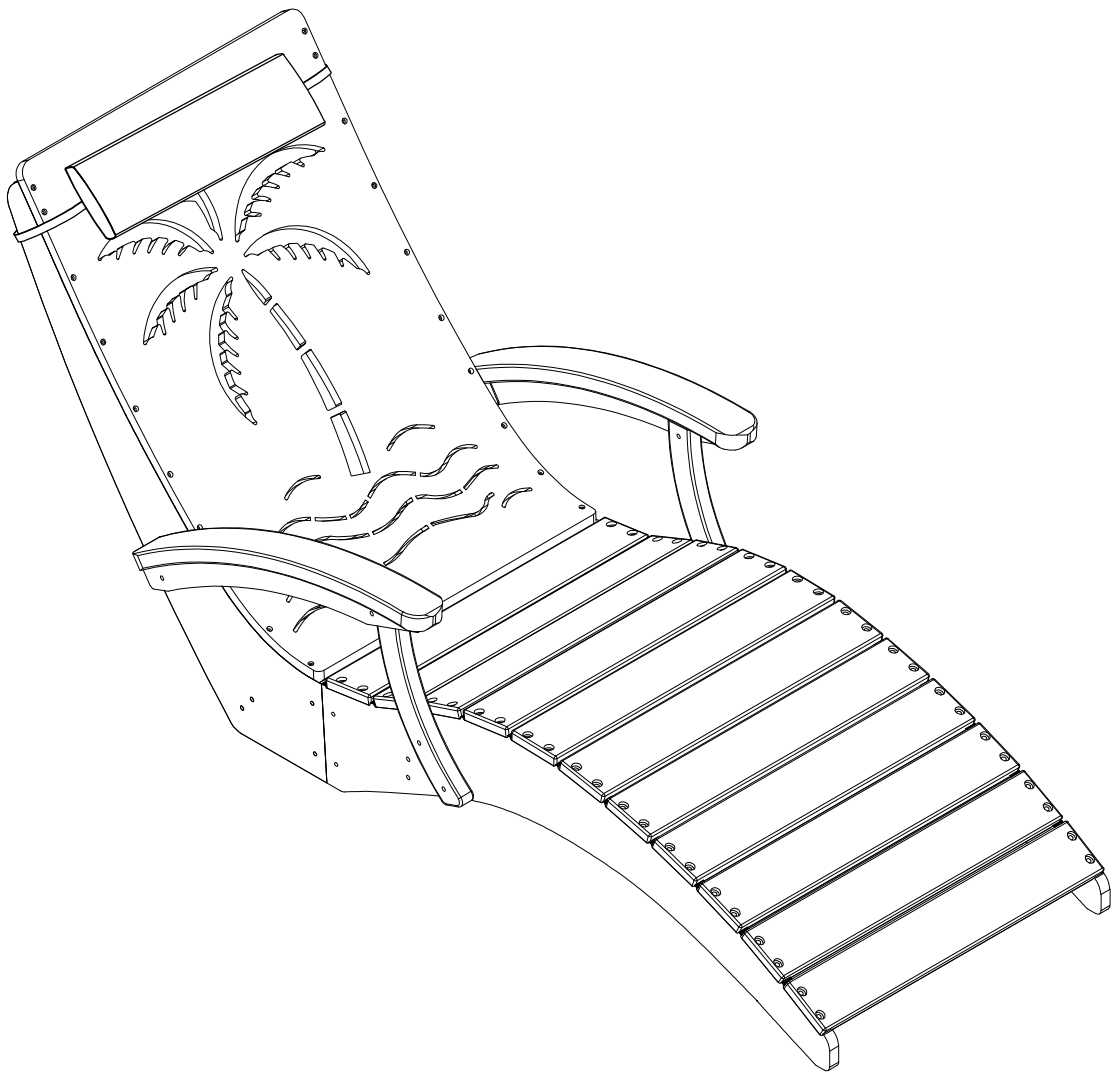

If you have any questions, feel free to email us
at zzwservice@gmail.com

THANK YOU

zzwservice@gmail.com

Register and Get the Full Benefit

It's our way of saying thank you.

Register your product to enjoy a number of benefits:

- (1) 1-year warranty extension
- (2) 24/7 quicker service and product support
- (3) Chance to test new products for free
- (4) Get specific discount on shop items

Register Way: Send " your name + order ID " to
zzwservice@gmail.com

Assembly Instruction

Parts List

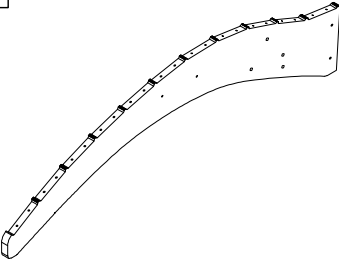
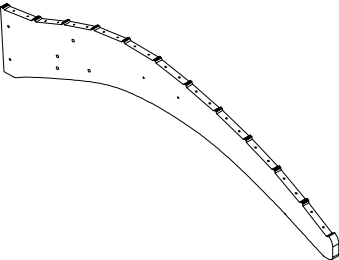
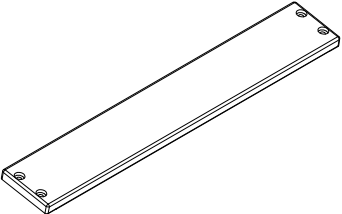
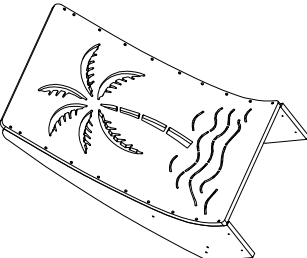
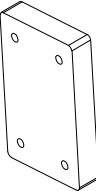
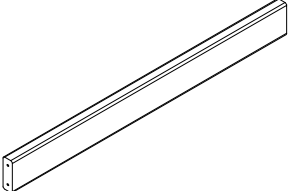
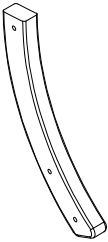
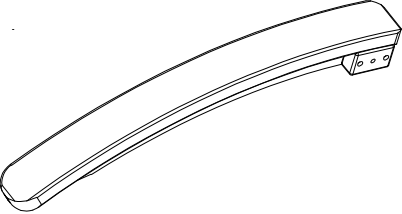
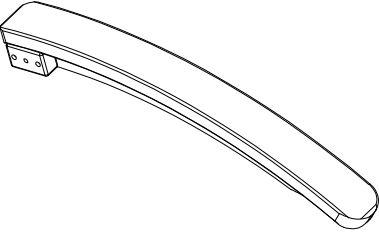
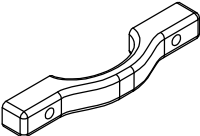
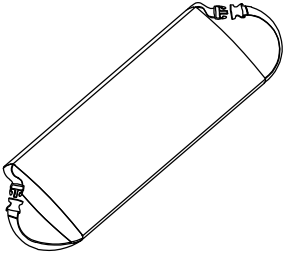
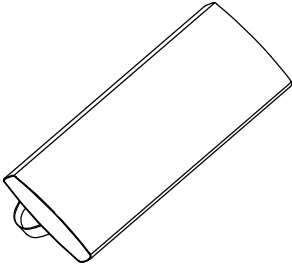
A 	B 	C 
2PCS	2PCS	22PCS
D 	E 	F 
2PCS	4PCS	4PCS
G 	H 	I 
4PCS	2PCS	2PCS
J 	K 	L 
4PCS	2PCS	2PCS

Upon unboxing, a slight paint odor is normal and will dissipate naturally within 1-2 days.

Assembly Instruction

Parts List

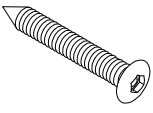
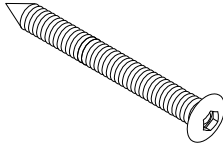
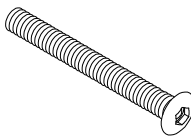
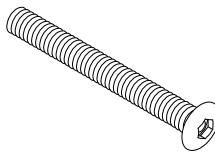
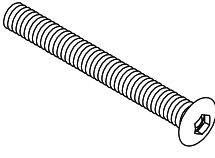
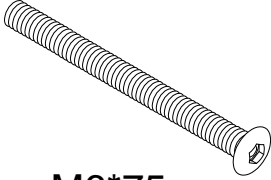
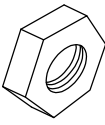
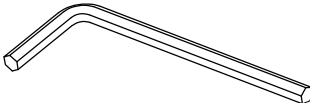
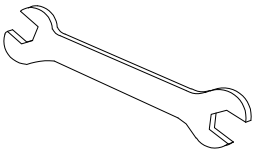
#1  M6*30mm 96PCS	#2  M6*45mm 16PCS	#3  M6*45mm 16PCS
#4  M6*50mm 8PCS	#5  M6*55mm 4PCS	#6  M6*75mm 4PCS
#7  M6mm 32PCS	#8  Allen Key(M6mm) 1PC	#9  Wrench(M6) 1PC

Assembly Instruction

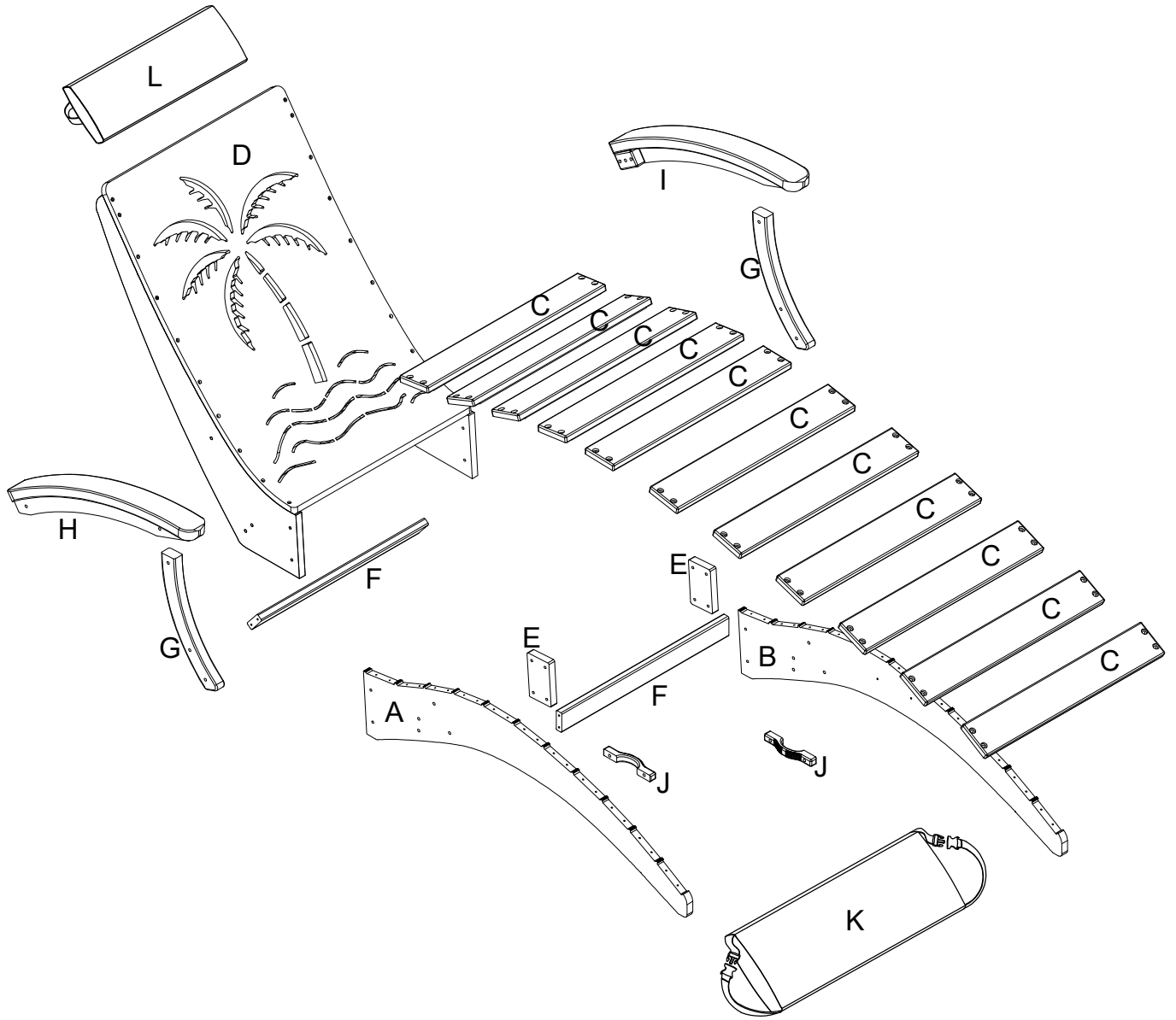

Assembly Instruction

STEP 1

A*1

J*1

#1*2

#8*1

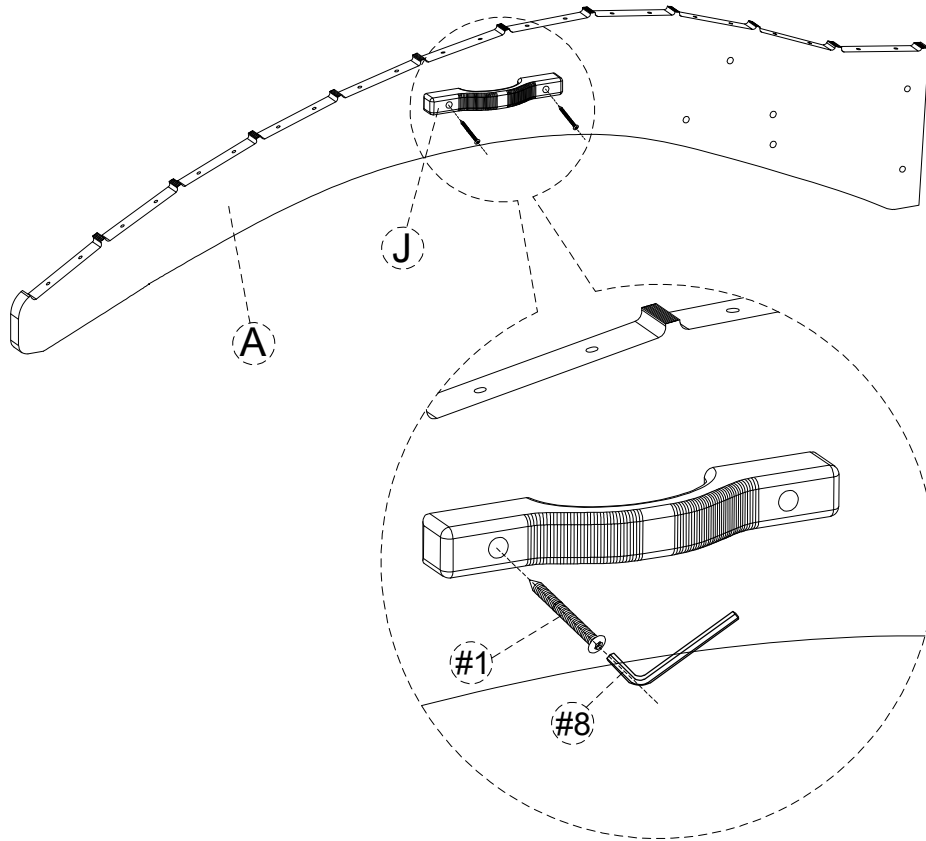

STEP 2

B*1

J*1

#1*2

#8*1

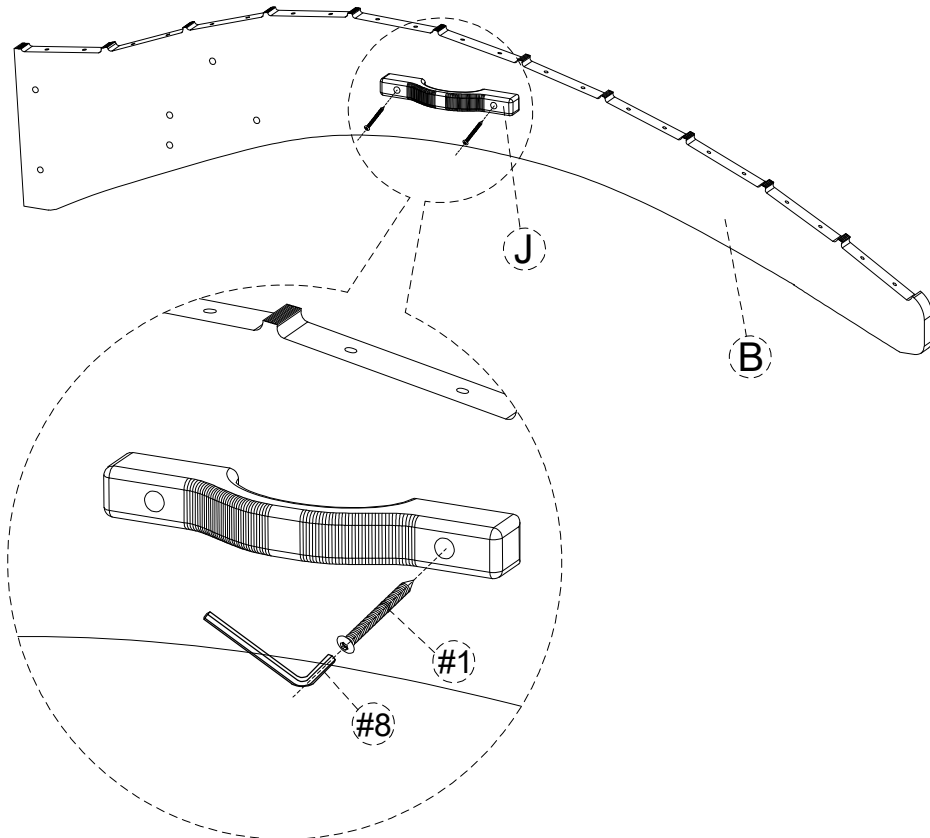

Assembly Instruction

STEP 3

D*1

F*1

#2*4

#8*1

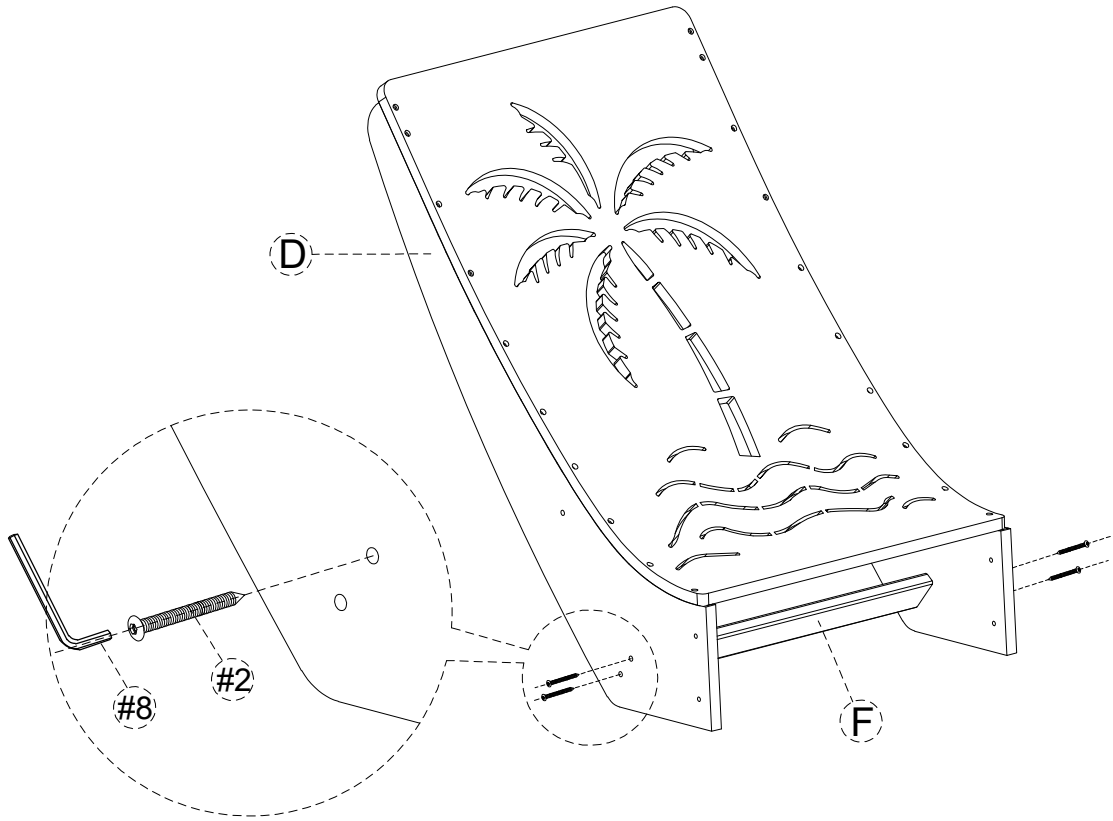

Place Part F in the corresponding position according to the screw hole locations.

STEP 4

A*1

B*1

F*1

#2*4

#8*1

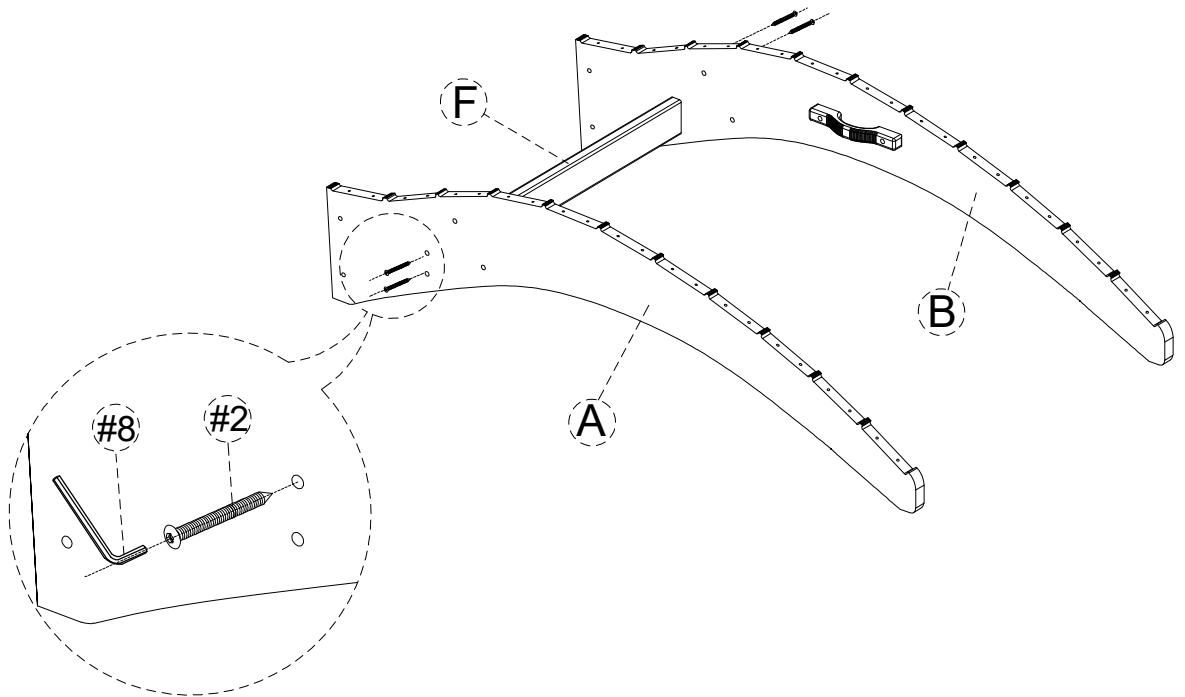

Assembly Instruction

STEP 5

A*1

B*1

D*1

E*1

#3*4

#7*4

#8*1

#9*1

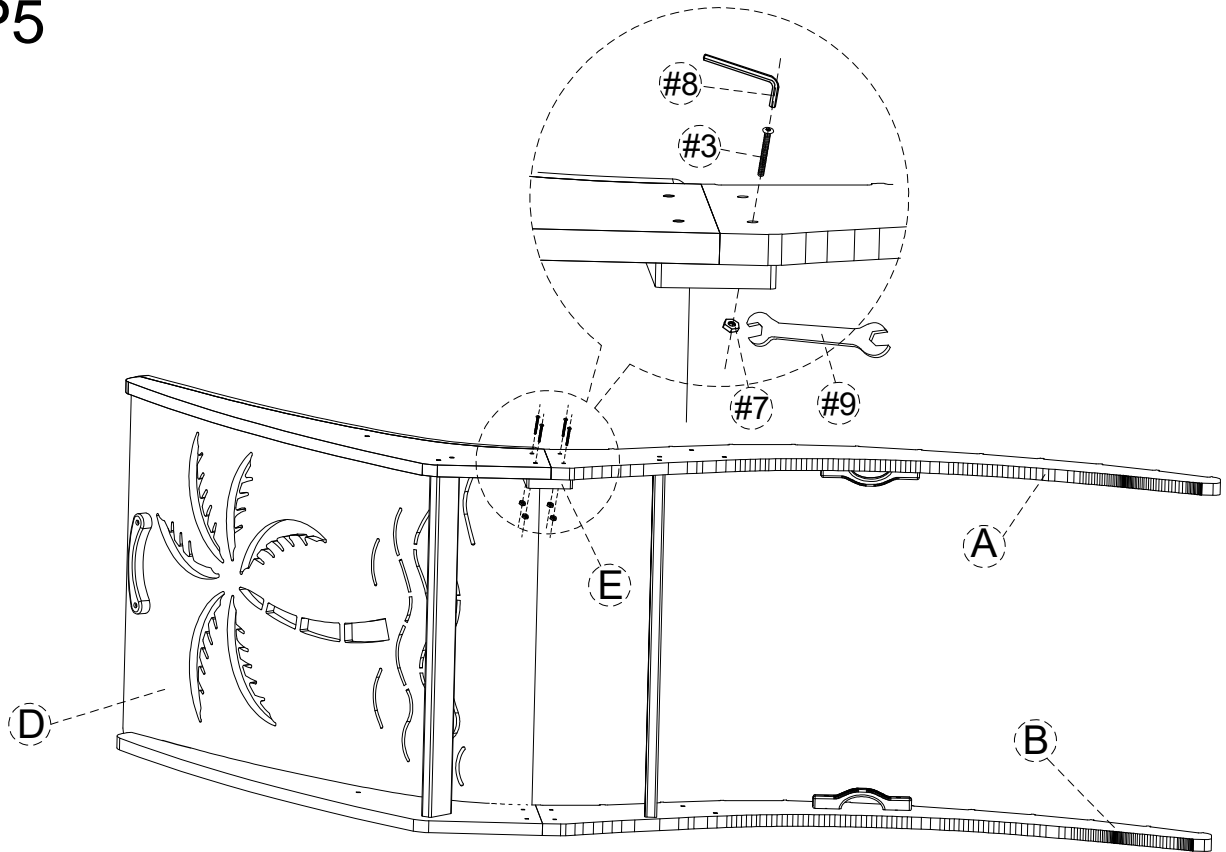

STEP 6

A*1

B*1

D*1

E*1

#3*4

#7*4

#8*1

#9*1

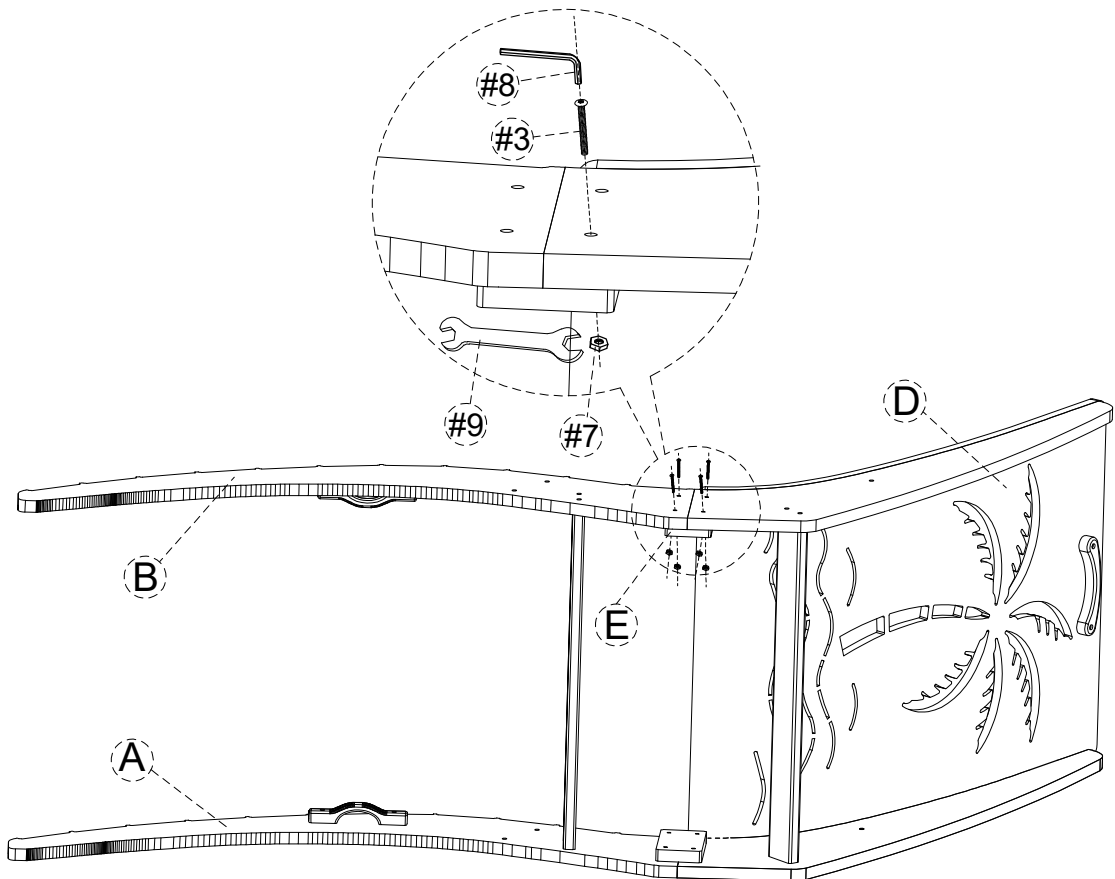

Assembly Instruction

STEP 7

A*1

B*1

C*2

D*1

#1*8

#8*1

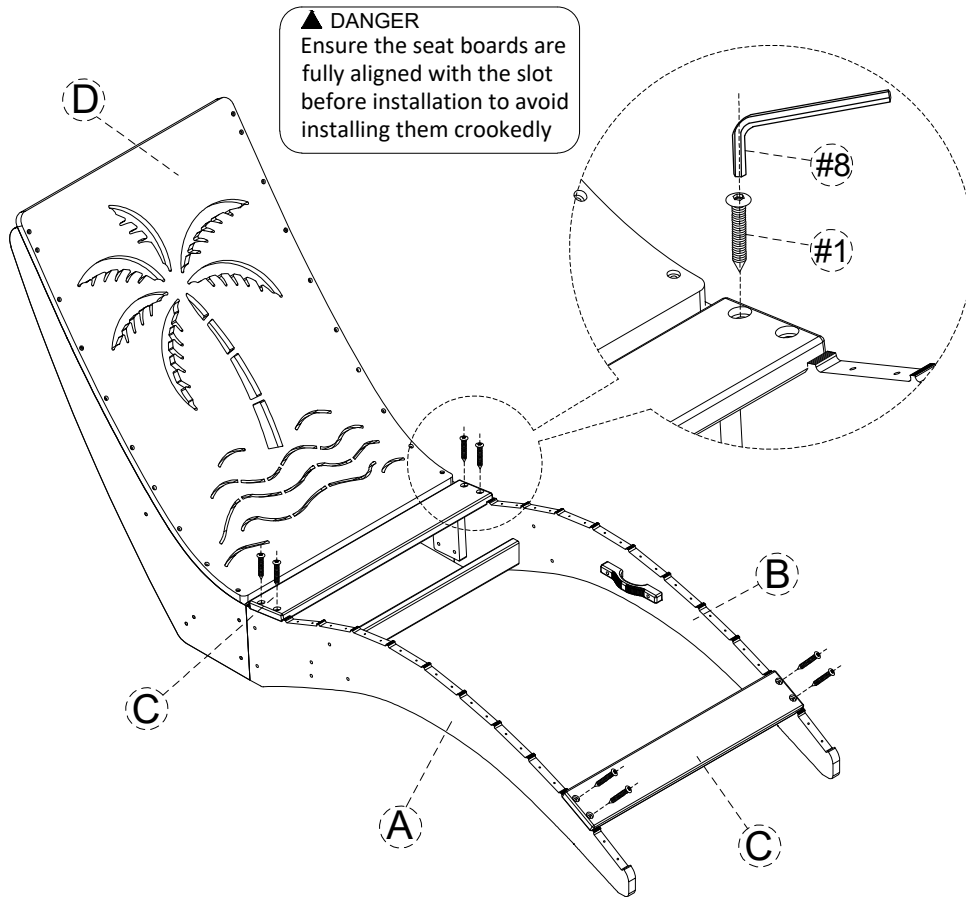

STEP 8

A*1

C*9

D*1

#1*36

#8*1

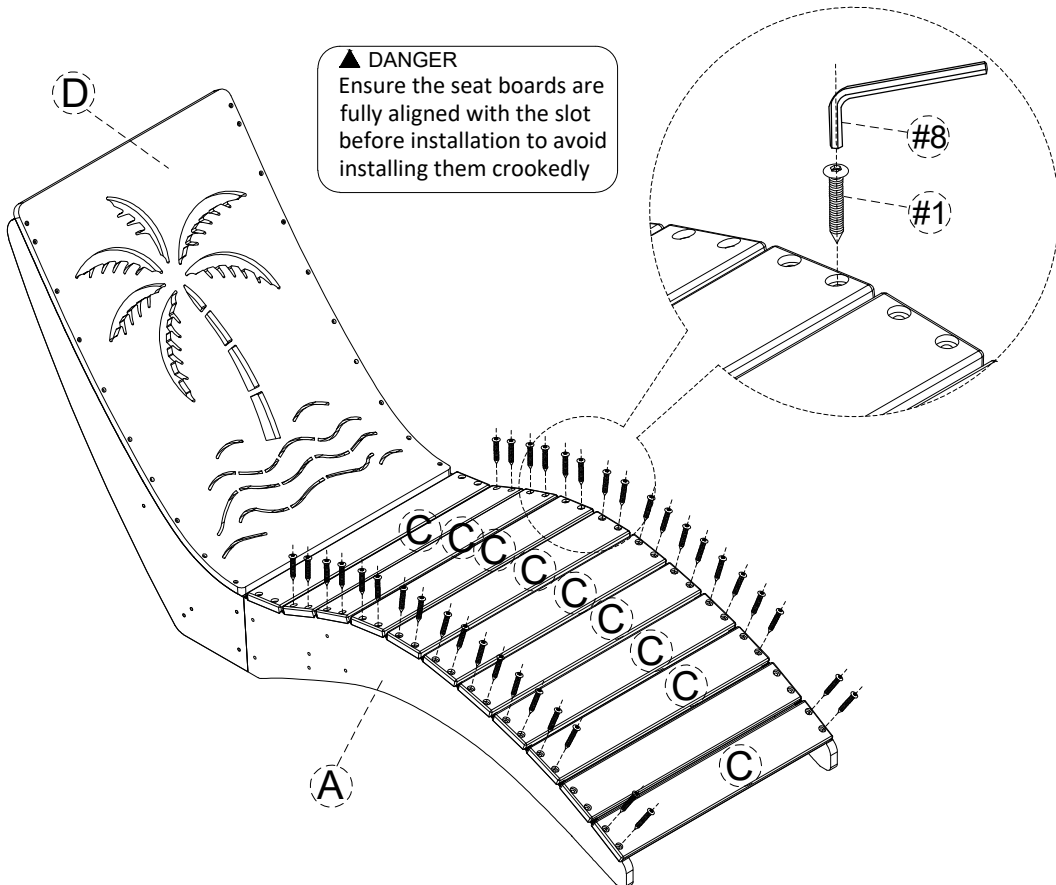

Assembly Instruction

STEP 9

B*1

D*1

G*2

#4*4

#7*4

#8*1

#9*1

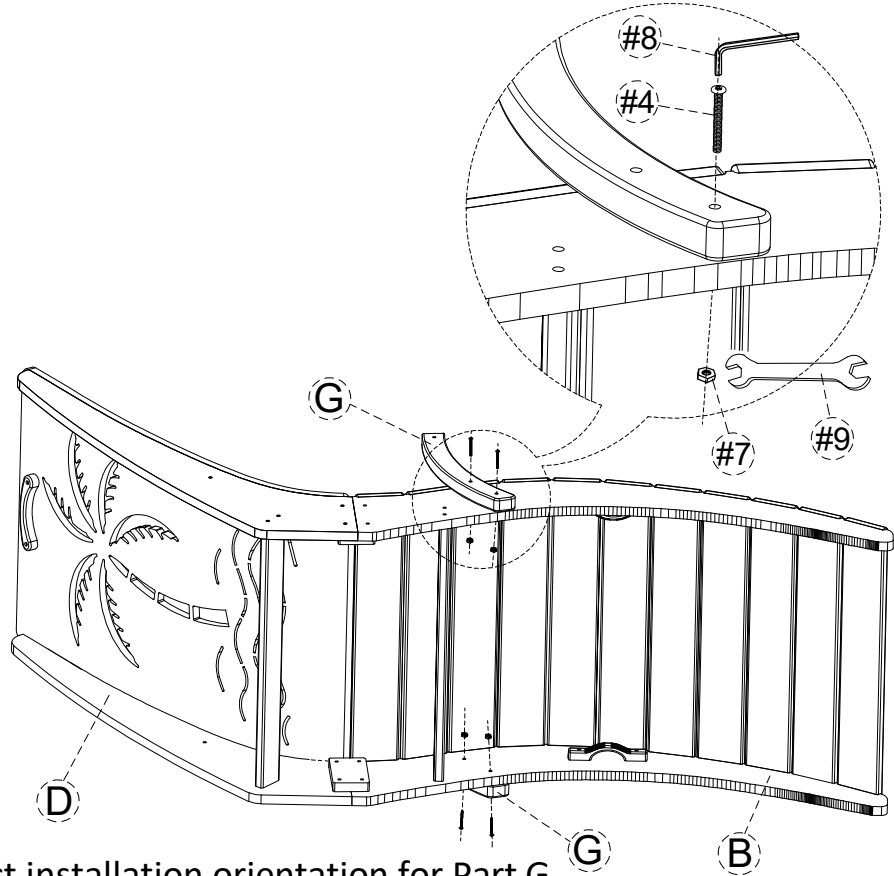

The figure shows the correct installation orientation for Part G.
Make sure that it is not installed backwards.

STEP 10

A*1

D*1

H*1

I*1

G*2

#5*2

#7*2

#8*1

#9*1

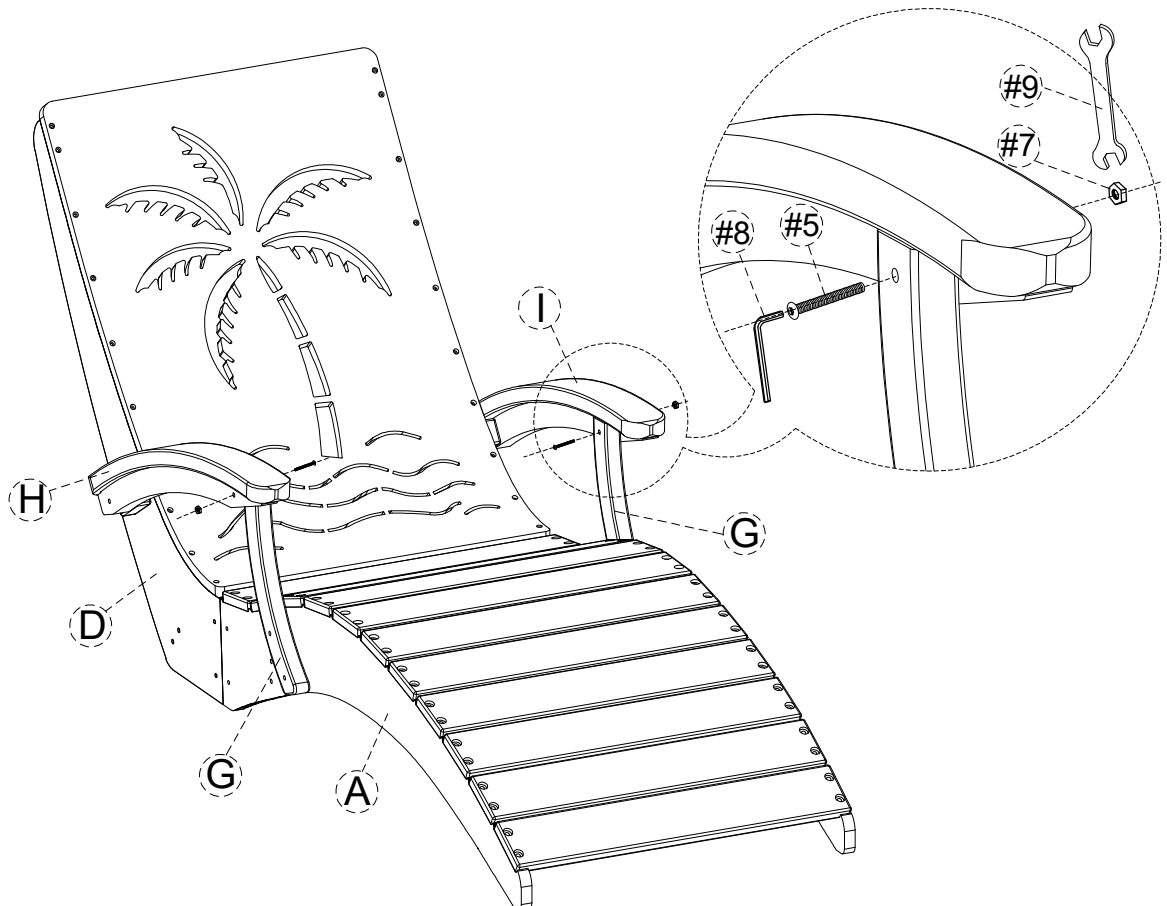

Assembly Instruction

STEP 11

D*1

H*1

I*1

#6*2

#7*2

#8*1

#9*1

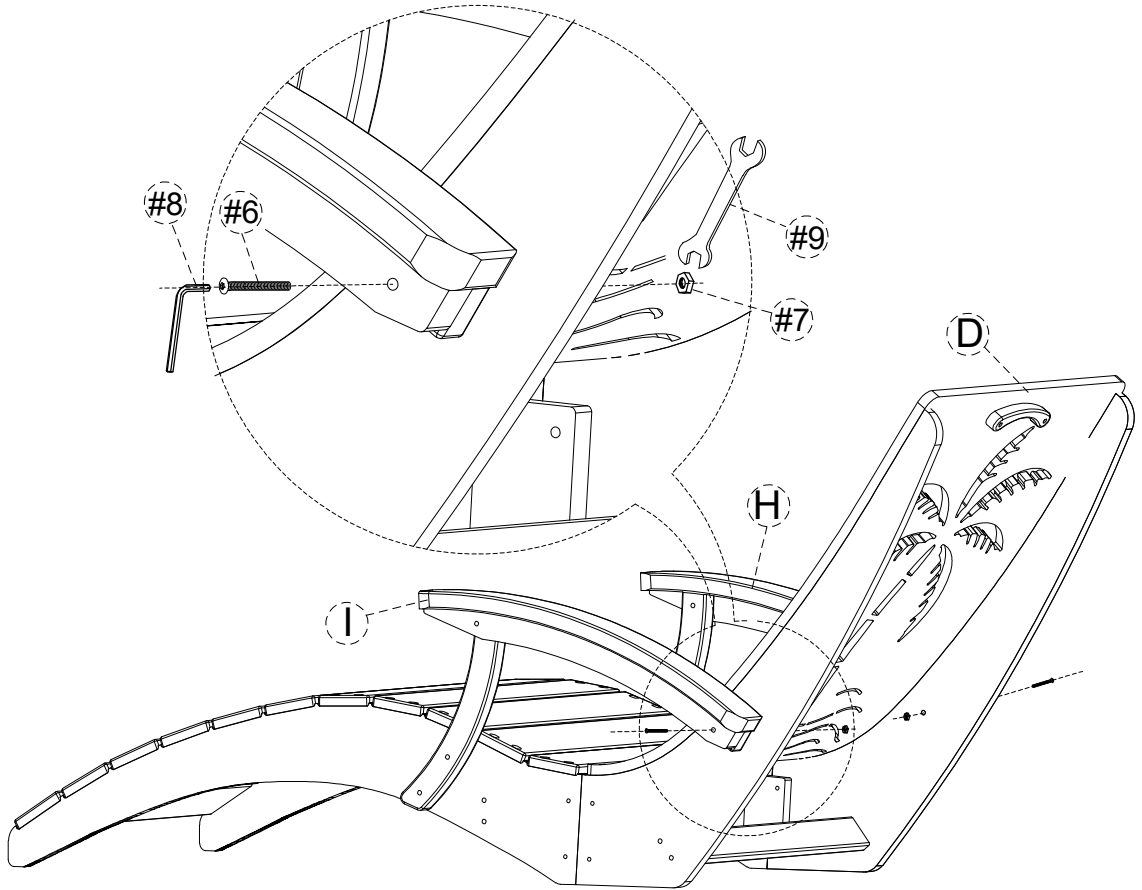

STEP 12

B*1

D*1

K*1

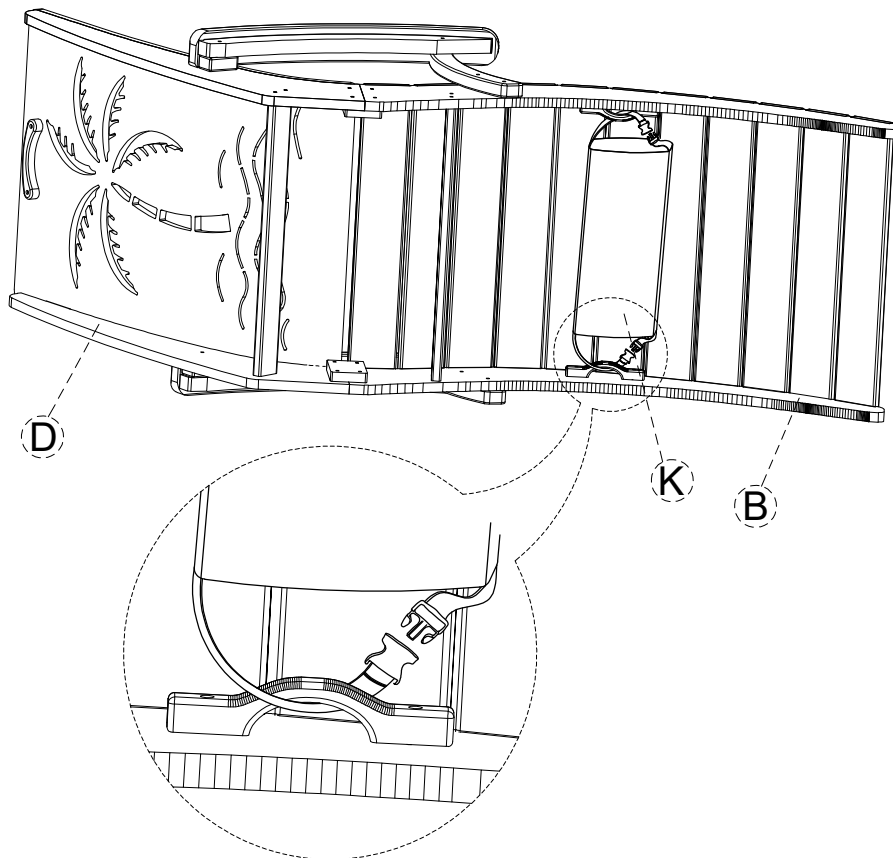

Assembly Instruction

STEP 13

A*1

D*1

L*1

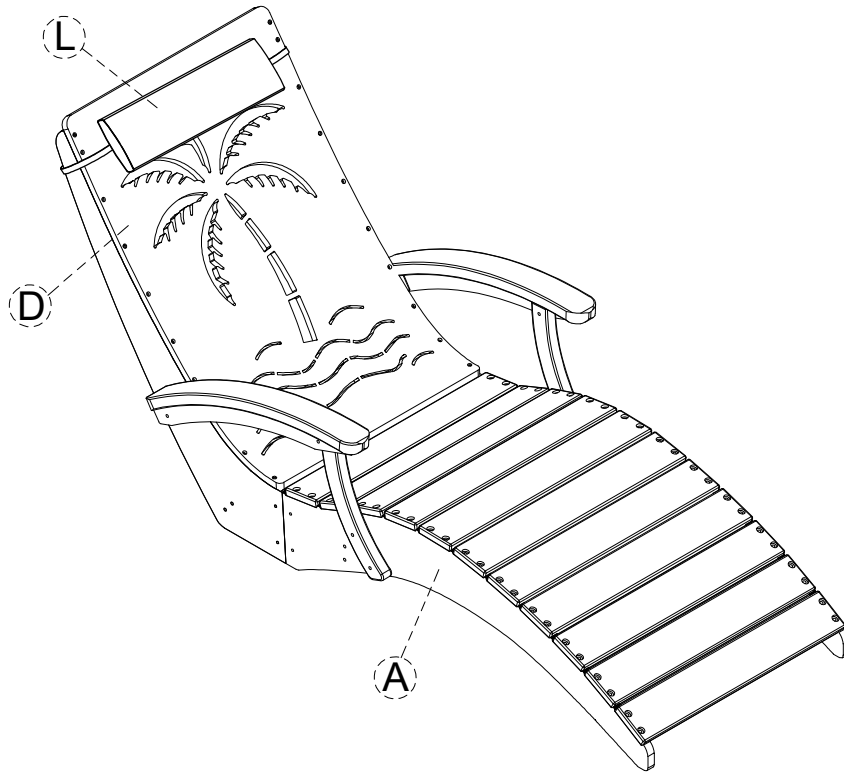

STEP 14

