

OFFICE CHAIR

ASSEMBLY INSTRUCTIONS

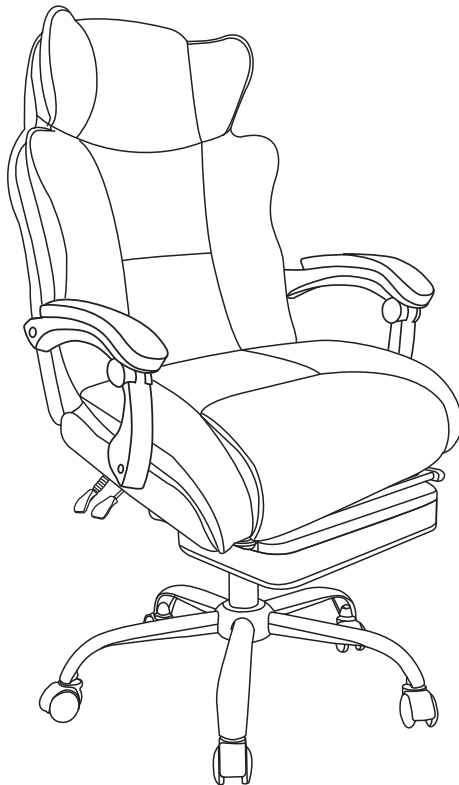

If you have any questions, feel free to email us at zzwservice@gmail.com.

THANK YOU

Register and Get the Full Benefit

It's our way of saying thank you.











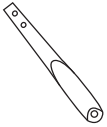
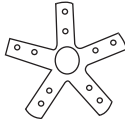
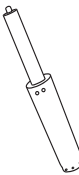
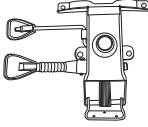

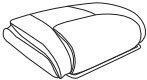

Register your product to enjoy a number of benefits:

- (1) 2-year warranty extension
- (2) 24/7 quicker service and product support
- (3) Chance to test new products for free
- (4) Get specific discount on shop items

Register Way: Send " your name + order ID " to zzwservice@gmail.com

Assembly Instruction

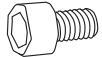
Parts List

A 	B 	C 	D 	E 
5PCS	5PCS	1PC	1PC	1PC
F 	G 	H 	I 	J 
1PC	1PC	1PC	1PC	1PC
K 	L 	M 	N 	O 
1PC	6PCS M6*30mm	3PCS M8*20mm	14PCS M6*20mm	4PCS M8*40mm
P 	Q 	R 	S 	T 
1PC	2PCS	1PC M5*8mm	4PCS	1PC

Please note: Please check carefully if there are any missing parts before installation. If there are any missing parts, please place all the parts and take pictures then tell us the missing part number. We will reply you as soon as possible. zzwservice@gmail.com

Assembly Instruction

Chair Assembly

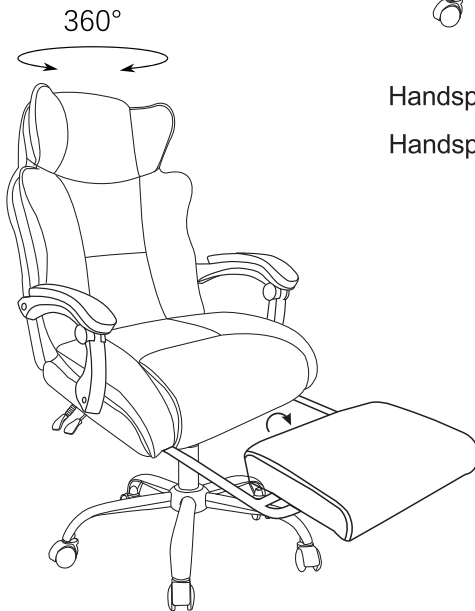
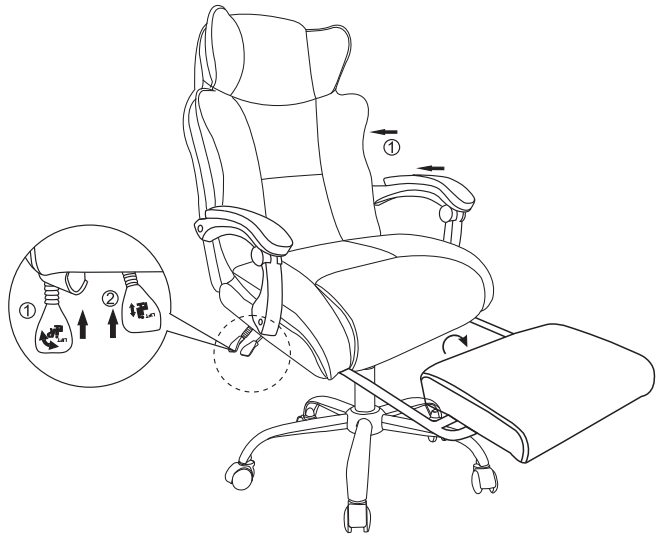

Handspike 1 is for inclining backrest.

Handspike 2 is for up and down the chair

Assembly Instruction

Chair Assembly

Step 1

A*5

B*5

C*1

N*10

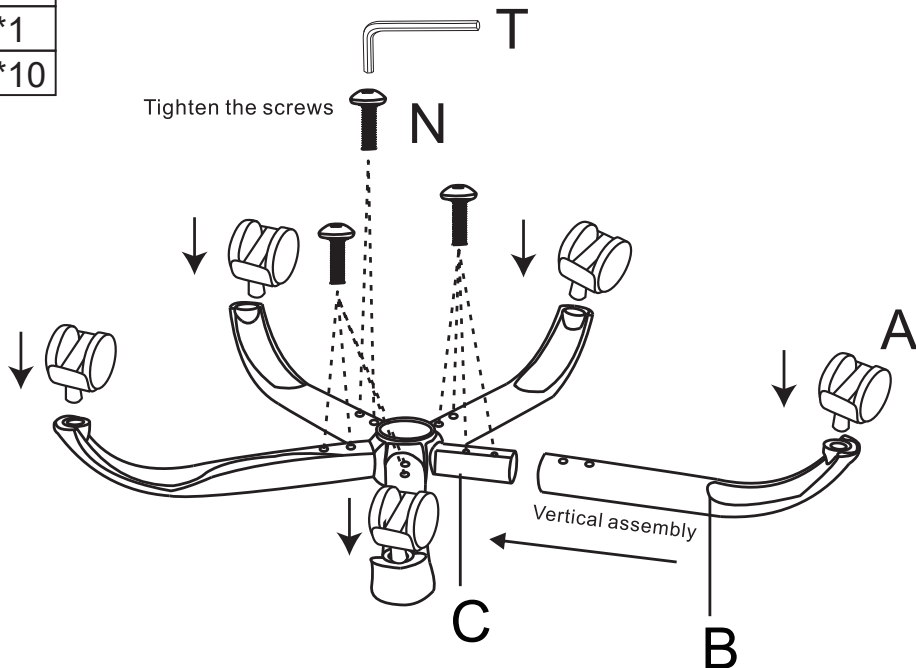

- (1) Connect star base(C) and 5 base legs(B) with 10 screws N , using the wrench (T).
- (2) Press the casters (A) into the holes at the end of the each base leg.

Assembly Instruction

Chair Assembly

Step 2

D*1

P*1

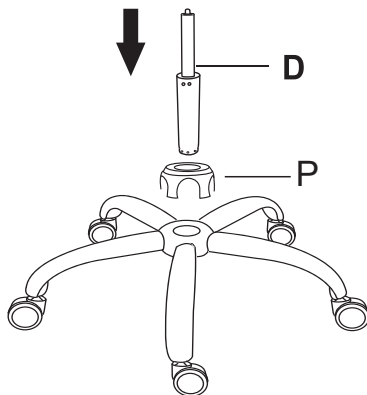

Put the star base cover (P) into the center of the star base, then insert the gas lift (D) into the center hole of the star base.

Step 3

E*1

G*1

N*4

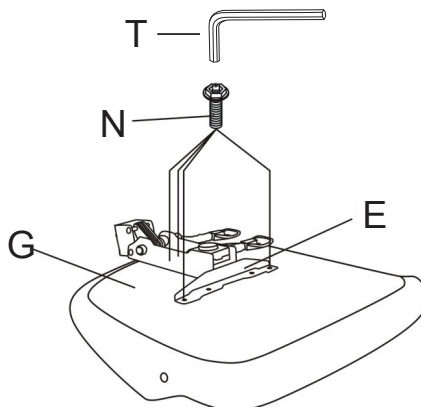

NOTICE:



Under-tighten all bolts in place at first.
As fully tightened may cause difficulties in Step 7 installation.

Assembly Instruction

Chair Assembly

Step 4

K*1

L*2

Q*2

R*1

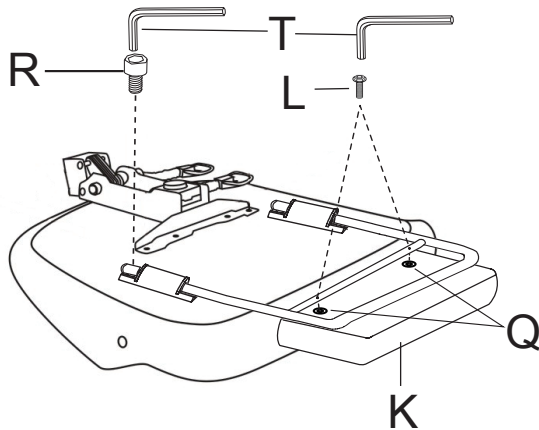

Pull out the footrest pole and fix the footrest with screws R & L.

Step 5

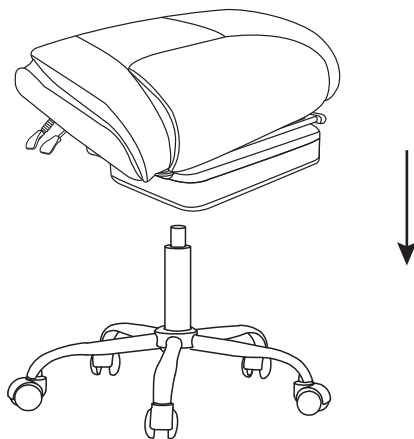

Insert air rod and the center base tube into the bottom plate under the seat cushion which has a hole in the middle. Press the cushion from top.

Assembly Instruction

Chair Assembly

Step 6

F*1

H*1

L*4

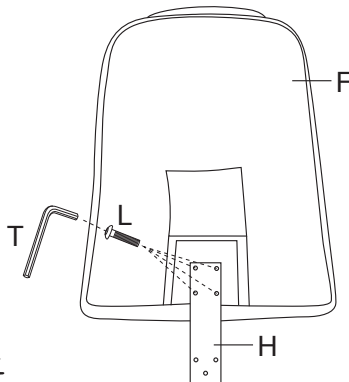

NOTICE: 

Under-tighten all bolts in place at first for Step 6 to 7.

Step 7

M*3

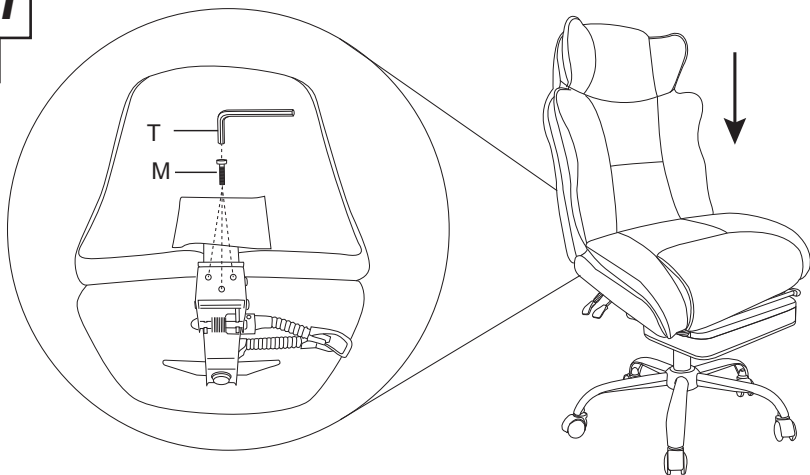

Fasten the seat cushion with steel plate, under-tighten with the screw M and wrench T.

NOTICE:

Adjust the back (F) and seat (G) to be vertical first, and then fully tightened all screws.

Assembly Instruction

Chair Assembly

Step 8

I*1

J*1

O*4

S*4

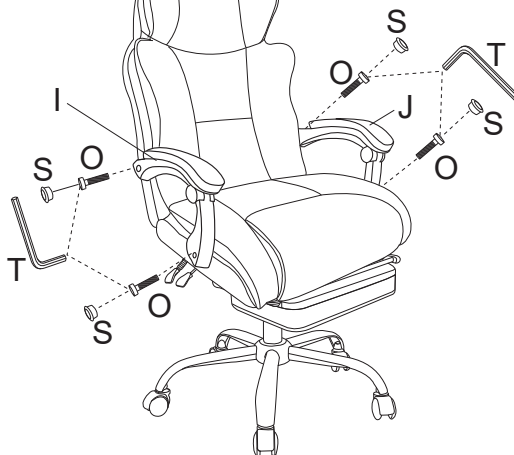

Fix the 2 armrests between the backrest and the seat cushion. Tighten the 4 screws firmly and then cover the screws with decoration caps.

Step 9



HEALTH CAUTION

- ⌘ If you have any concerns regarding your health, consult your doctor before using this product.
- ⌘ Individuals with pacemakers should not use this product.
- ⌘ If you experience pain in a muscle or joint for a prolonged period of time. Discontinue use and consult your doctor. Persistent pain could be a symptom of a more serious condition.

MAINTENANCE INSTRUCTIONS

TO STORE:

Place unit in its box or safe, dry, cool place. Avoid contact with sharp edges or pointed objects which might cut or puncture the fabric. Do not wrap power cord around the unit. Do not hang the unit by power cord.

TO CLEAN:

- ⌘ Insure the unit is unplugged from the power source, and allow to cool before cleaning.
- ⌘ Do not place in any liquid to clean. Clean fabric cover by wiping with a damp sponge, using a mild detergent or suds. Pat dry with clean, dry cloth.
- ⌘ Do not use abrasive cleaners, brushes, gasoline, kerosene, glass /furniture polish, paint thinner or water hotter than 120°C to clean the unit.
- ⌘ To clean the unit, make sure the massager is unplugged. Allow the unit to cool and the wipe down with a damp clean cloth. Do not use any strong chemical cleaners.

