

# MALONE®

## **\*ATTENTION CUSTOMERS\***

Thank you for your recent purchase of a Malone trailer.

*Please inspect all parts and hardware bags prior to assembly.*

*\*Important documents may come directly from the dealer you've purchased the trailer from.*

*\*\* IF your trailer includes a large red envelope (found in the axle box), place the envelope containing important documents in a safe spot.*

If you encounter damage of any packaging or parts, or find that parts are missing - please email us with photos and your Proof of Purchase at:

Email: [support@maloneautoracks.com](mailto:support@maloneautoracks.com)

For the most updated instruction manual, please visit:  
[maloneautoracks.com/dealerimages/pdf/MPG535.pdf](http://maloneautoracks.com/dealerimages/pdf/MPG535.pdf)

Thank you from all of us at Malone



MPG535

CHANGING THE WAY YOU GET THERE

# MALONE<sup>®</sup>

**CHANGING THE WAY YOU GET THERE**

## Important Note

### Product Warranty & Registration Form

All information is confidential and used exclusively by MALONE only.

Dear Customer,

Thank you for your purchase of a Malone Product.

In order to be eligible for the Malone Warranty program, we ask that you contact us online at the link provided below within 30 days of purchase. You can also mail this letter back to the address at the bottom.

- Online: <https://maloneautoracks.com/product-registration.php>

We will require the information below.

Here is the information collected:

First Name: \_\_\_\_\_

Last Name: \_\_\_\_\_

Address: \_\_\_\_\_

Address2: \_\_\_\_\_

City: \_\_\_\_\_

State: \_\_\_\_\_

Zip: \_\_\_\_\_

Country: \_\_\_\_\_

Email: \_\_\_\_\_

Phone: \_\_\_\_\_

Product Description/Name: \_\_\_\_\_

Product MPG#: \_\_\_\_\_

Date Purchased: \_\_\_\_\_

Store Where Purchased: \_\_\_\_\_

Purchase Price: \_\_\_\_\_

**Thank you for choosing Malone!**

*Please Note: Registration Form is not a valid Proof of Purchase. Please retain your original receipt for any future warranty claims.*

# MALONE®

MPG535

**CHANGING THE WAY YOU GET THERE**

## **Malone MegaSport™ Trailer**

*Model MPG535 Assembly Instructions*



Take a few moments and read through these instructions to familiarize yourself with the step by step assembly process before you begin turning wrenches.

Unpack and sort the components into groups as shown in the following pages.

Then assemble each group in order. Lets get started !!

### **Required Tools:**

- (2) 3/4" wrenches • (2) 9/16" wrenches (a deep socket is recommended)
- Large flat blade screw driver • 7/16" wrench • 3/8" wrench and socket
- 13/16" socket • Large Phillips head screw driver • Rubber hammer

*Visit us at [maloneautoracks.com](http://maloneautoracks.com)  
for more fine products and accessories.*

**MALONE®**  
CHANGING THE WAY YOU GET THERE

**Group 1:  
Frame  
Components**

Bag 11412

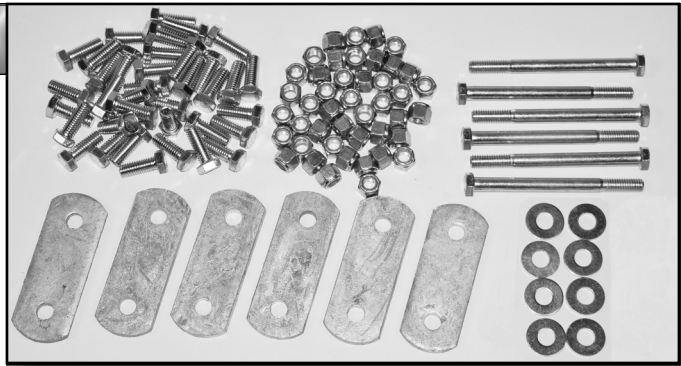

**Main Frame**



**Tongue Frame**



**Group 2:  
Axle / Spring  
Components**

Bag 11412-1

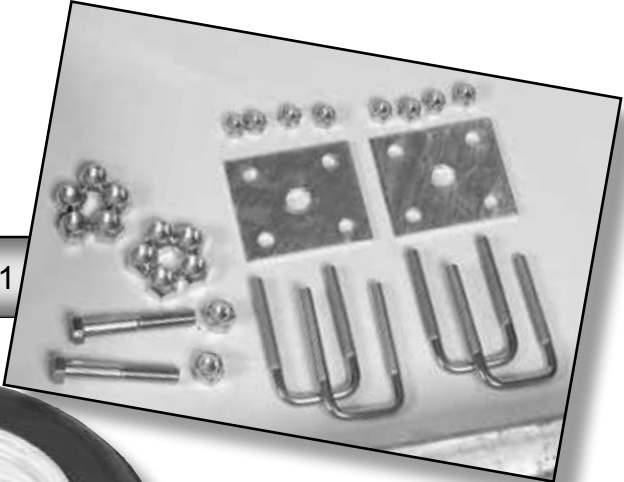

**Visit [www.maloneautoracks.com/Replacement-Parts](http://www.maloneautoracks.com/Replacement-Parts)  
for all of your spare part needs**

**Group 3: Lighting Components**



Bag 11468



**Group 4: Fender Components**

Bag 11464

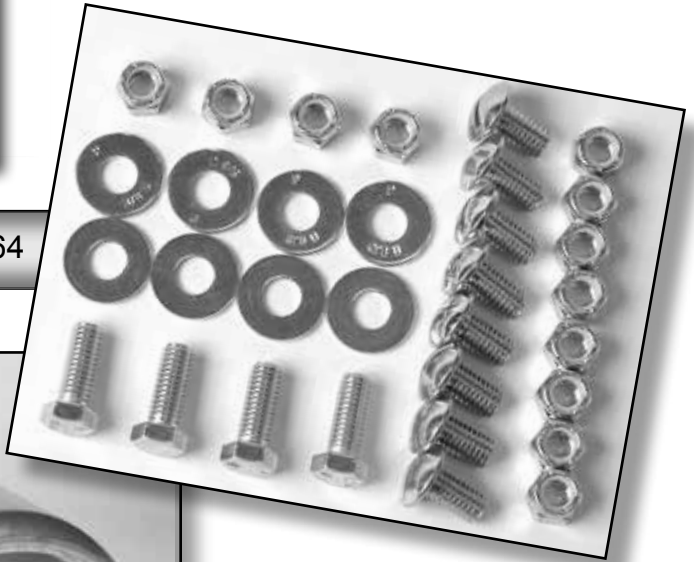

**Group 5: Coupler Components**



Bag 11494

**Visit [www.maloneautoracks.com/Replacement-Parts](http://www.maloneautoracks.com/Replacement-Parts)  
for all of your spare part needs**

Group 6:  
Load Bar  
Components

Bag 11412-2

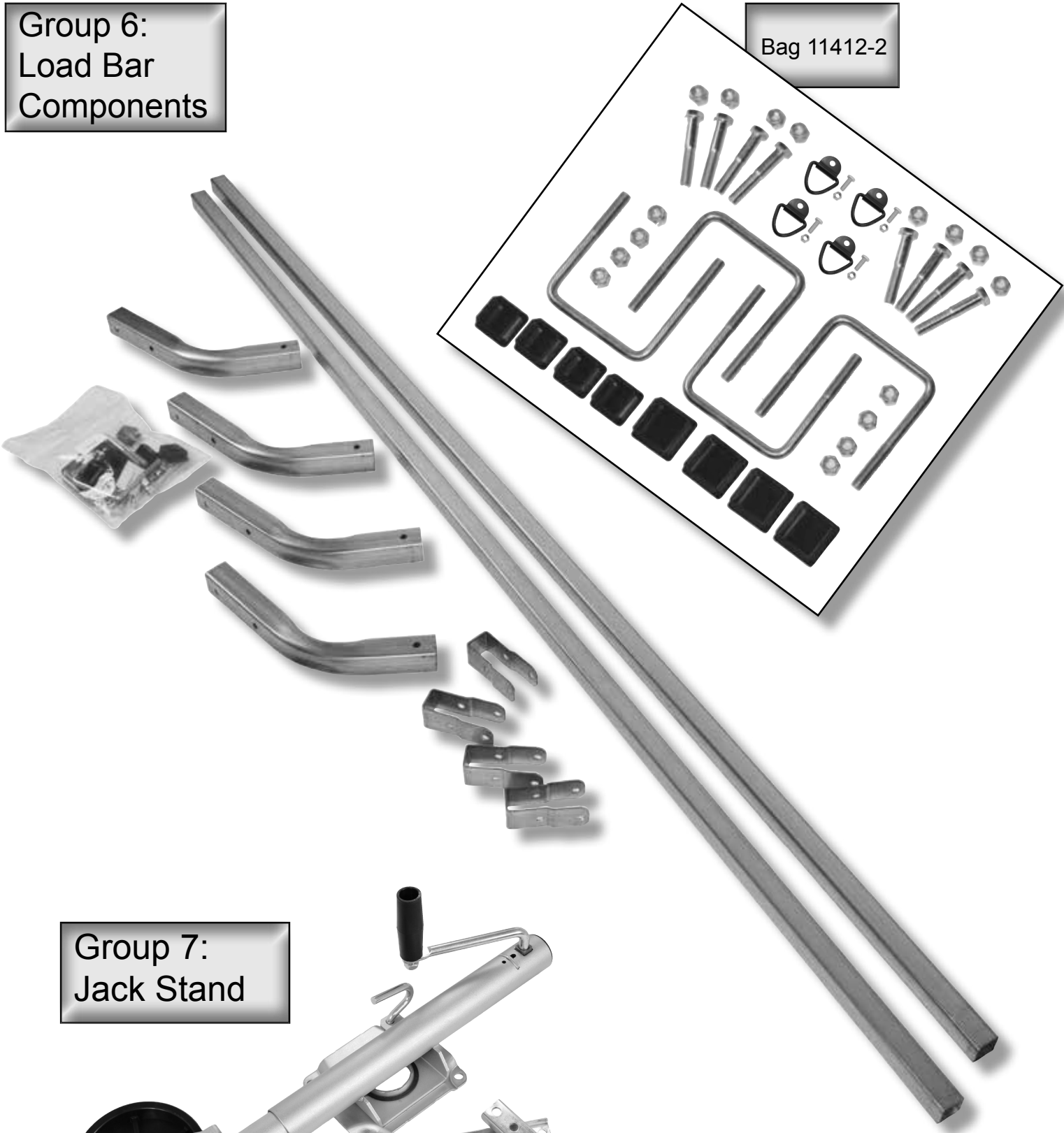

Group 7:  
Jack Stand

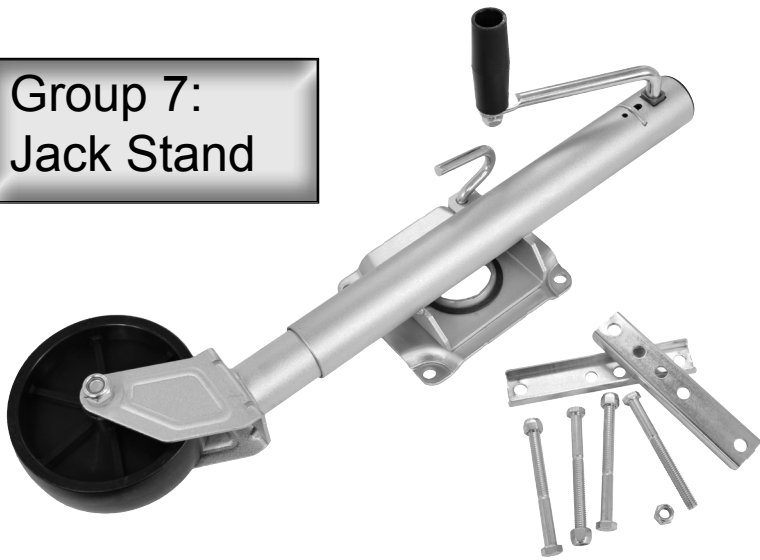

# MAIN FRAME ASSEMBLY (Group 1)

1. We start the assembly of the Main frame first, right side up. The spring bracket mounting holes should be facing down. Aline all the cross members as shown.

NOTE: Direction of 3rd cross member faces forward. Install the bolts downward from the top and secure with nylon lock nut. Hand Tighten Only.

Measuring from the rear corners diagonally to the front corners will insure your frame is square. Adjust as needed and fully secure the 4 corners.

We now flip the main frame on its back to make it easier to install the tongue frame, springs and axle. Once the springs and axle assembly is installed we will flip the trailer over to complete the assembly.

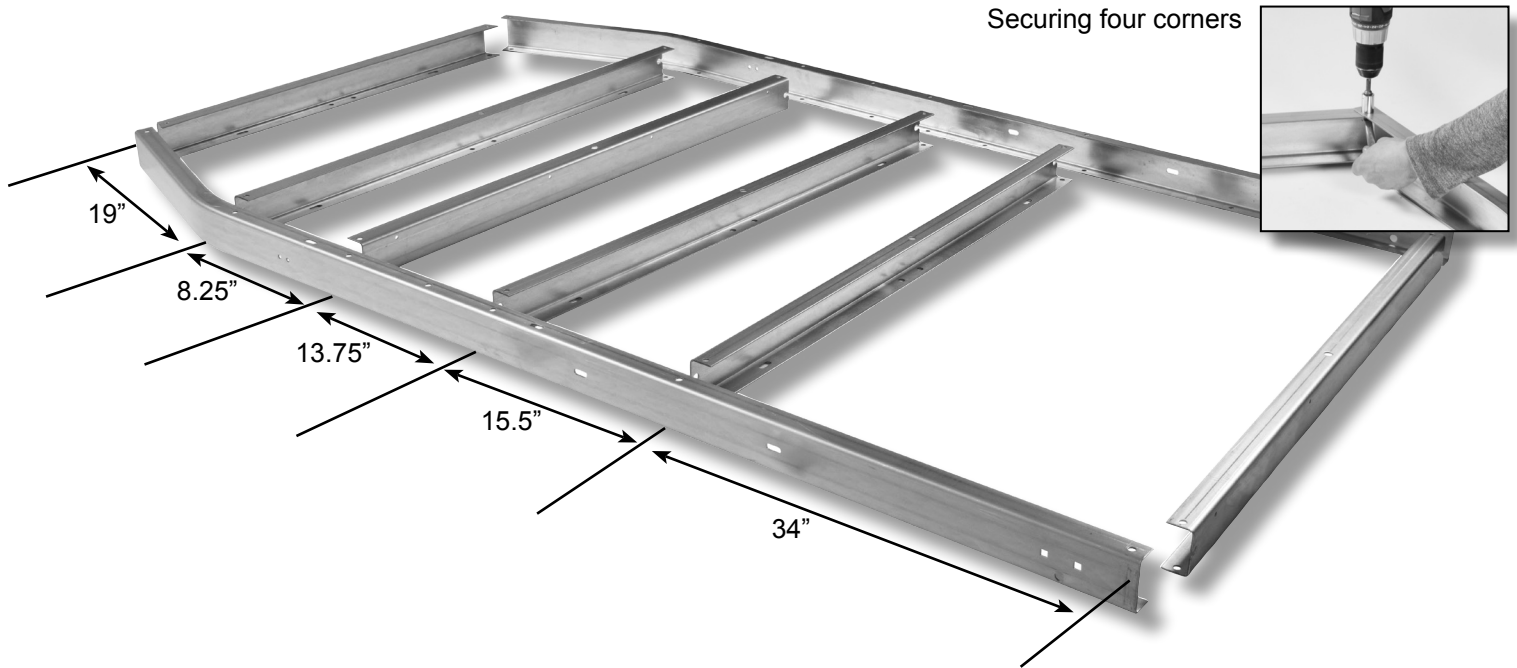

2. With the frame components upside down as shown install the remaining hardware for the cross members, fully tighten the four corners first, again measuring to insure the frame is square.

NOTE: Skip the bolts for the 4th cross member from the front until we add the frame rail for the tongue. Leave these loose.

The spring bracket mounting holes should be facing up.

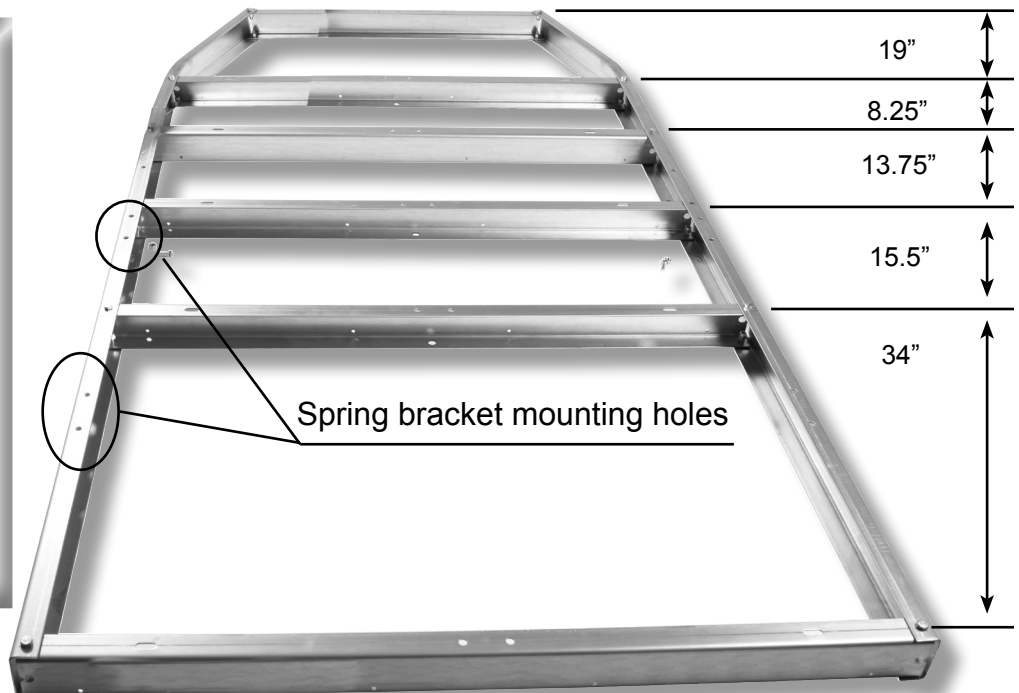

## TONGUE ASSEMBLY (GROUP 1)

3. Identify the hitch end of the tongue by the 3 holes on the left (drivers) side.

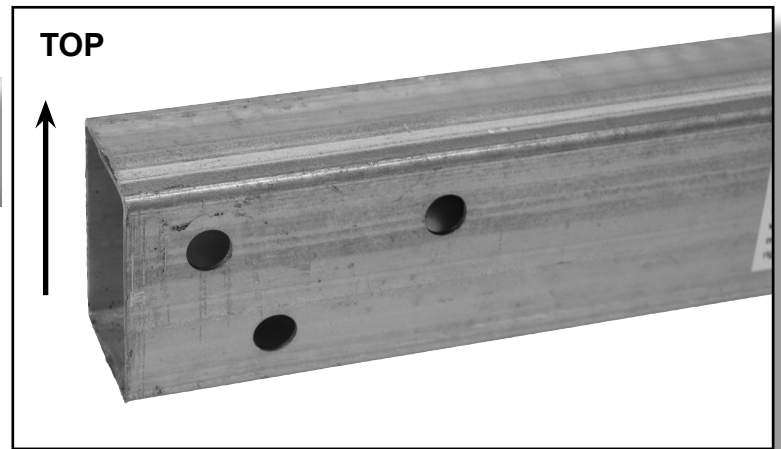

4. Pass the wiring harness (with a plug at each end), into the open end of the tongue, leaving enough excess at the front to reach the vehicle. NOTE: MAKE SURE YOUR PLUG MATCHES THE VEHICLE CONNECTION. IF NOT REVERSE YOUR WIRING HARNESS NOW.

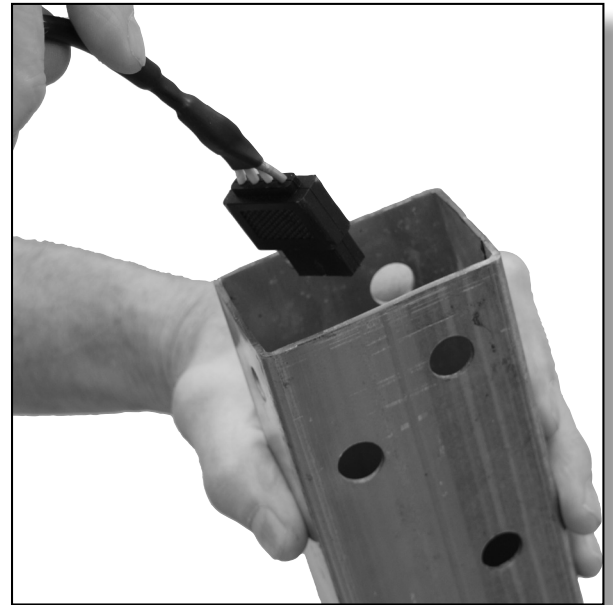

5. Add the tongue safety bolt at the non-coupler end as pictured. NOTE: Wires removed for clarity



6. Begin attaching the tongue components with the side frame rails first, then the tongue down the middle.

Tighten the side rails beginning at the 4th cross member back, going through both the main frame rail and the cross member, joining them together. Working your way forwards, the side rails will pinch together at the tongue. You'll use washers on the front 2 cross members utilizing the larger oval holes.



7. Secure the tongue to the main frame and frame rails with the flat plates and longer bolts. Placing one plate on each side of the tongue as pictured.



8. Attach the spring hanger brackets to the frame. Right at the end of tongues side rail. The U shaped shackle bolt brackets mount to the front and the C shaped "slipper" brackets mount to the rear as shown. Use 3/8" x 1" bolts and nuts. Assemble with the nuts on the inside of the frame rails. Fully tighten all 8 bolts now.

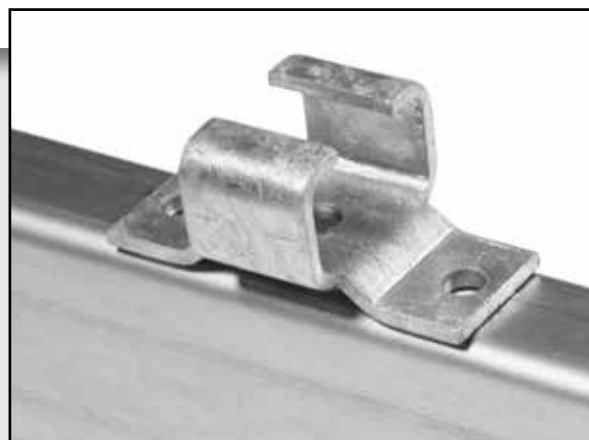
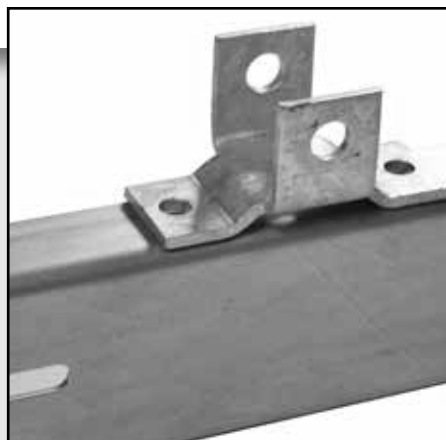

# SPRING AND AXLE ASSEMBLY (Group 2)

*\*Set the large red envelope  
(in the axle box) containing  
important documents in a safe spot.*

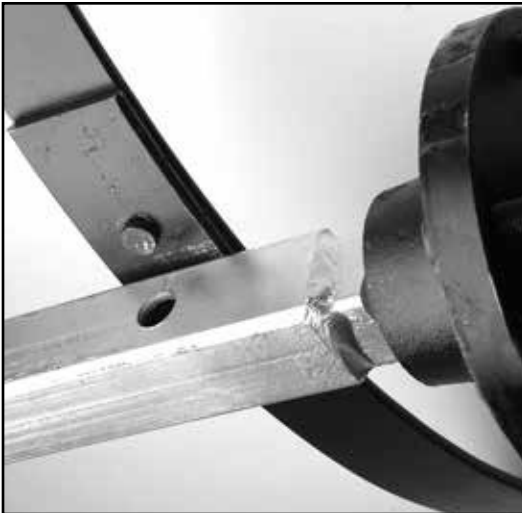
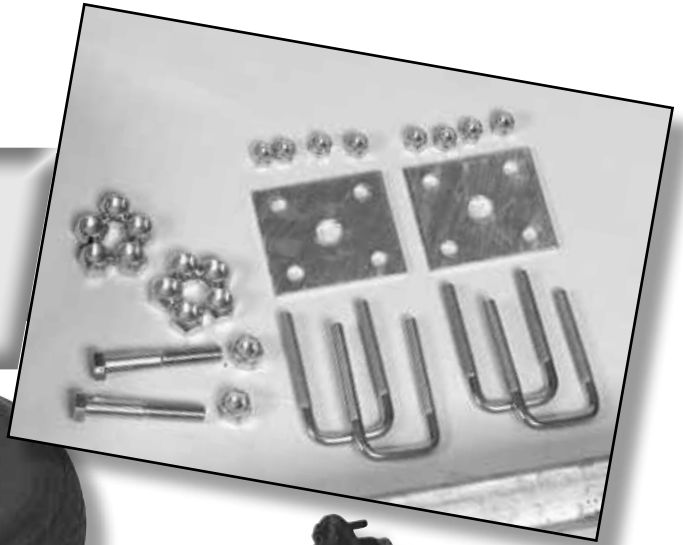

2. Spin the axle to find the side with the spring centering holes. These holes mate with the spring center stud (shown to the left)

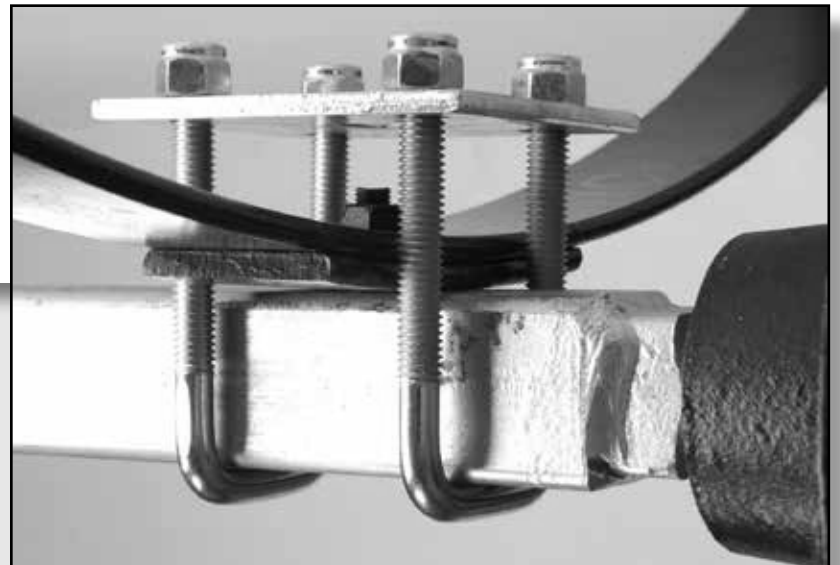

3. Lay the springs on top of the axle with the centering studs in the holes in the axle. Then assemble the U-bolts, tie plates and nuts as shown.

**Make sure both springs are turned with the ends facing the same way!**

4. Run each nut down **UNTIL IT TOUCHES THE PLATE ONLY! DON'T TIGHTEN !!**

You will need to wiggle the springs to fit them into the spring brackets in the next step.

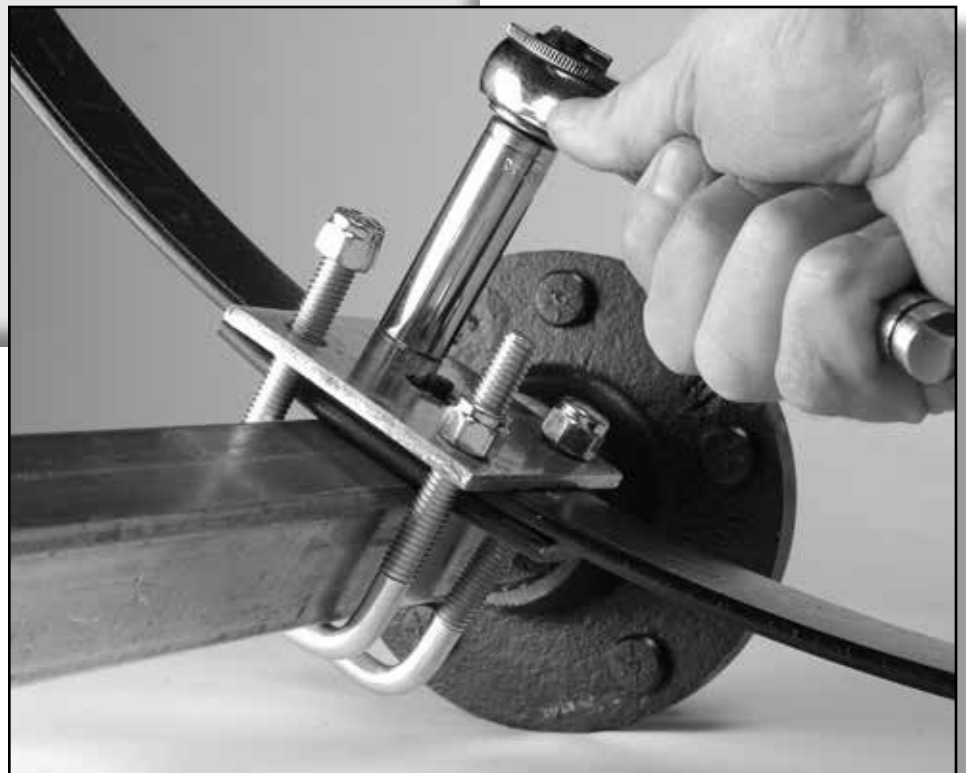

5. Lift the axle/spring assembly to the trailer frame and slide the slipper spring ends into the slipper spring brackets as shown.



6. Wiggle the spring eyes into the front hanger brackets and bolt using 1/2" x 3" bolts and self locking nuts. Tighten the shackle bolts ONLY until they grip the sides of the brackets. This is a hinge, the spring needs to move freely.



7. Now that the axle assembly is attached to the frame, tighten the axle plate U-bolts evenly until there is a slight bend in the tie plates.

8. Mount the wheels onto the hubs and hand tighten the lug nuts.



9. With 2 people Standing on the side the trailer, lift the frame rail member at the corners and flip the trailer over onto the tires. Carefully lower onto wheels.

ALWAYS BEND FROM YOUR KNEES WHEN LIFTING. THIS TRAILER IS HEAVY TO FLIP SAFELY ALONE, GET SOME FRIENDS TO ASSIST YOU.

10. Tighten the lug nuts firmly to 75 to 85 foot pounds of torque.



11. With the trailer now turned right-side up, go back and fully tighten all bolts and nuts along the frame rails and cross members from Step 1.



## LIGHT ASSEMBLY (Group 3)

### L.E.D. REFERENCE:

#### Trailer Wiring Color Code

- Brown = running lights
- Yellow = left turn / left brake
- Green = right turn / right brake
- White = ground



1. First attach the taillight brackets to the frame as shown using 3/8" x 1" carriage head bolts and nuts. No washers are needed.

2. Mount the taillights to the light brackets using the nuts provided with the light kit. \*Making sure to Attach/secure the license plate holder to the backside of the drivers side lamp bracket as shown.

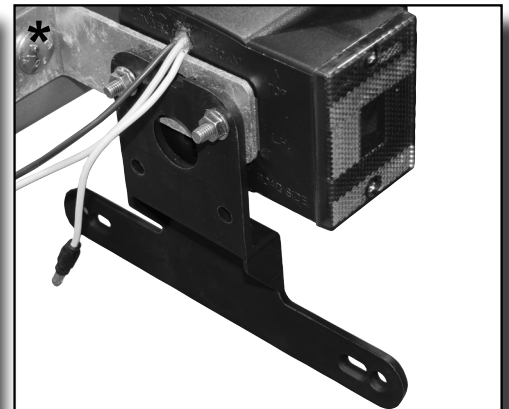
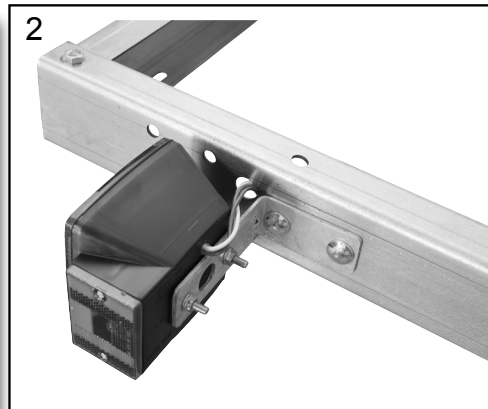
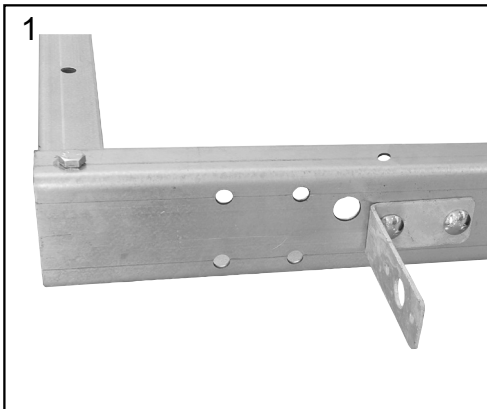

3. Use the holes just behind the second cross member to mount the amber side lights. First, push the wire leads through the outside holes and the lamp stud through the center hole.

4. Secure with the lamp stud nut.

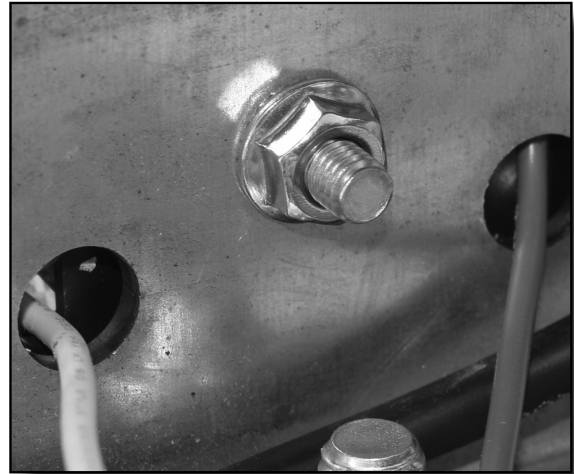
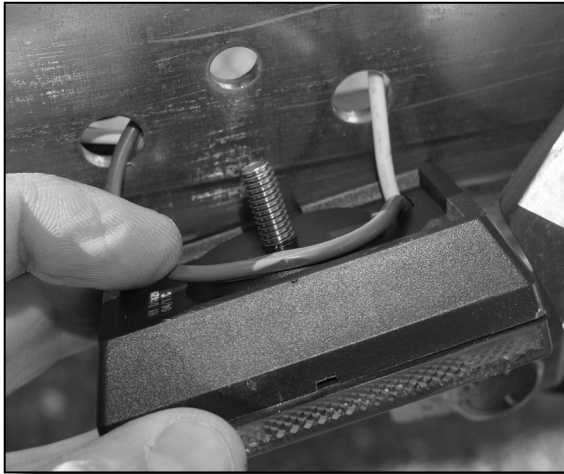

5. Plug in the remaining wiring harness into the connection behind the tongue. Looking at the end connections, route the GREEN/BROWN/WHITE wire along the passengers side. Route the YELLOW/BROWN/WHITE along the drivers side as shown.



6. Next, we'll route the wires through the cross members, One lead at a time, all the way through the trailer to the tail lights.

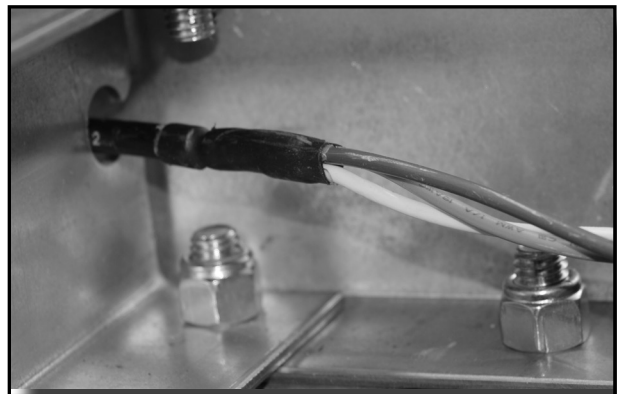

7. With the wires routed all the way to the tail lights, firmly grasp the wiring connections and plug-in matching colored leads/wires. Repeat with all remaining lights.

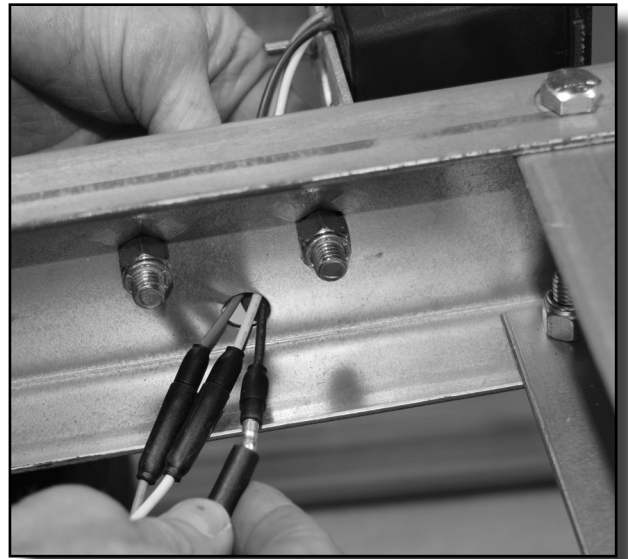

8. Use the clips provided to secure the wire to the inside of the frame channel as shown.

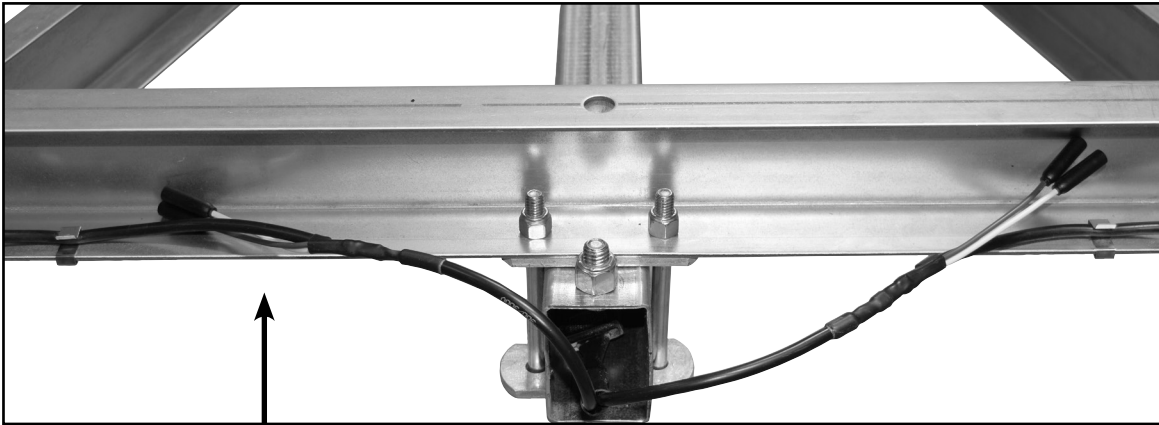

NOTE:  
UNUSED PLUGS ARE FOR AUXILIARY  
ACCESSORIES LIKE THE MALONE MPG543  
CHARGING UNIT. (NOT INCLUDED)



## FENDER ASSEMBLY (Group 4)



1. Connect all 4 fender brackets to the fenders using 3/8" x 3/4" slot head screws and nuts. Assemble with the nuts to the inside of the fenders as shown. No washers here. Fully tighten all 8 screws and nuts.

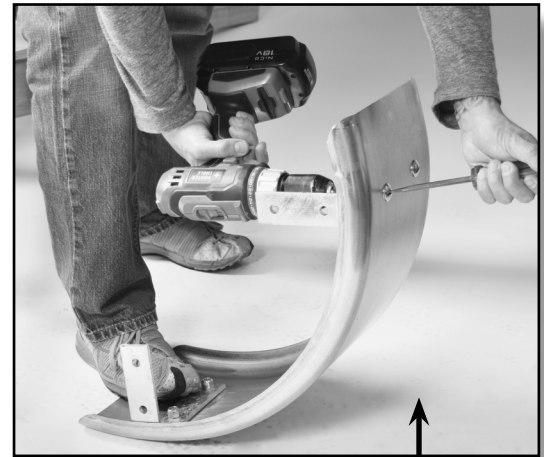

**Note:** Fenders are symmetrical and fit on either side of the trailer. Install trick shown here.

**Note** that when bolting the mounting brackets to the frame you will install a washer on the inside of the frame rail, under the nut.

2. Using 3/8" x 1" bolts, attach the fender brackets to the slotted holes in the frame as shown. Secure with nylon nuts. Place washer under nut.

3. Tighten bolts fully and repeat for other side.

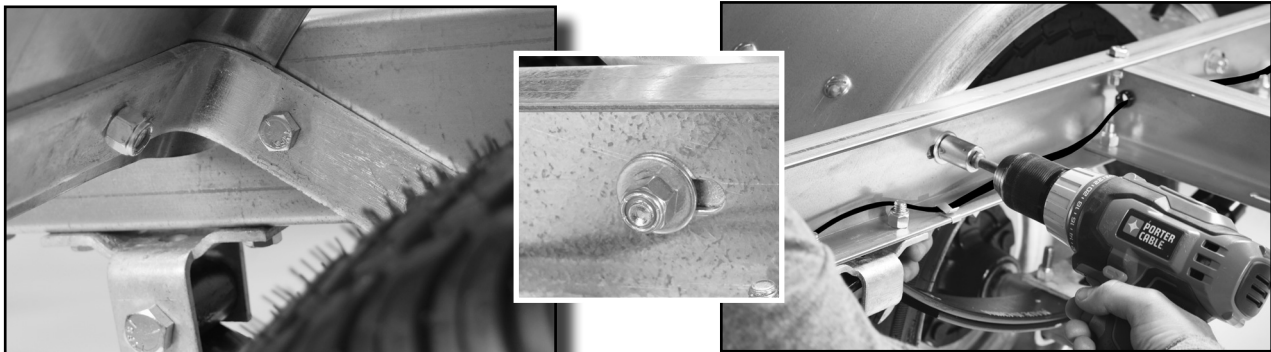

# COUPLER ASSEMBLY (Group 5)



1. Assemble the tongue skid and safety chain assembly with a 3/8" x 1-1/2" bolt as shown. Use washers above and below the chain ends.



2. Place the skid and chain assembly under the tongue and insert the bolt up through the skid bolt hole on the bottom of the tongue as shown.

3. Slip the nylon lock nut over the bolt and hand tighten.

4. Check that the rear end of the skid is still in its hole in the bottom of the tongue. Fully tighten the bolt and lock nut.

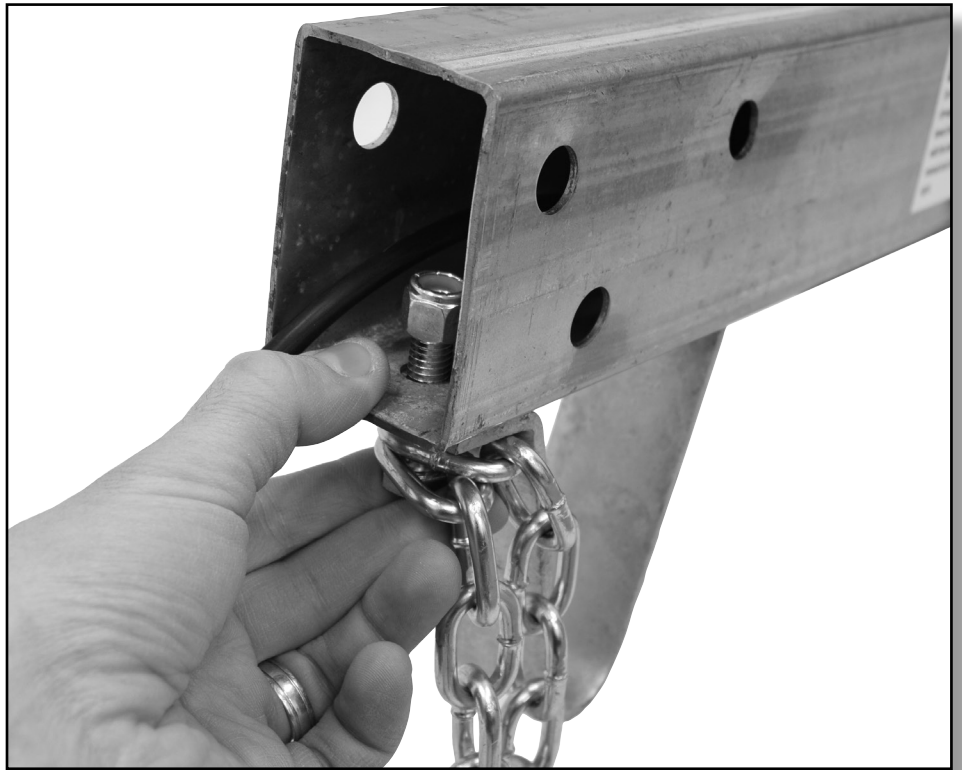

5. Install the coupler and coupler handle onto the tongue as shown. Then tighten until the coupler firmly grips the tongue. Don't over tighten and crush the tongue.  
**NOTE: OVER TIGHTENING WILL PREVENT THE COUPLER LATCH FROM FUNCTIONING PROPERLY.**

## LOAD BAR ASSEMBLY (Group 6)

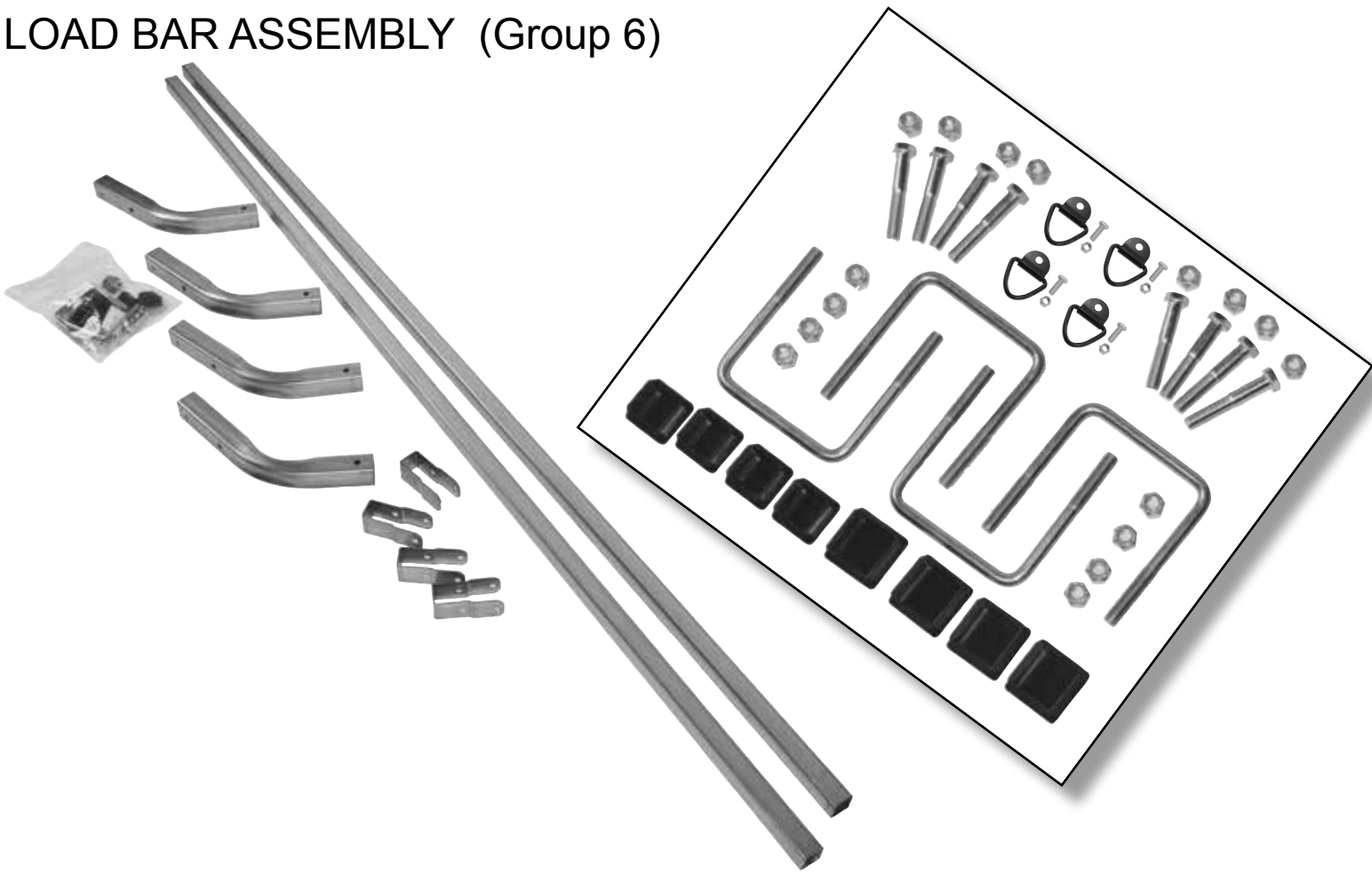

1. Attach rear load bar support tube at the rear cross member. One in each rear corner on the trailer and tighten. Secure with U-Bolts and nylon nuts.

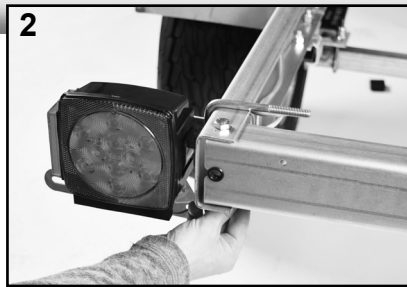

2. Attach the front support tubes at the second cross member back from the front. Then tighten the U-bolts. Repeat for second front support tube.



3. Use your hammer and carefully pound the end caps into the ends of the support tubes.



4. Slip the load bar brackets over the load bars (as shown) and loosely install the two small bolts / nuts through each bracket trapping the load bars inside the brackets.



5. Install and hand tighten the bolts holding each bracket to the support tube.

6. Center the load bars to the trailer, then tighten all 8 bracket bolts

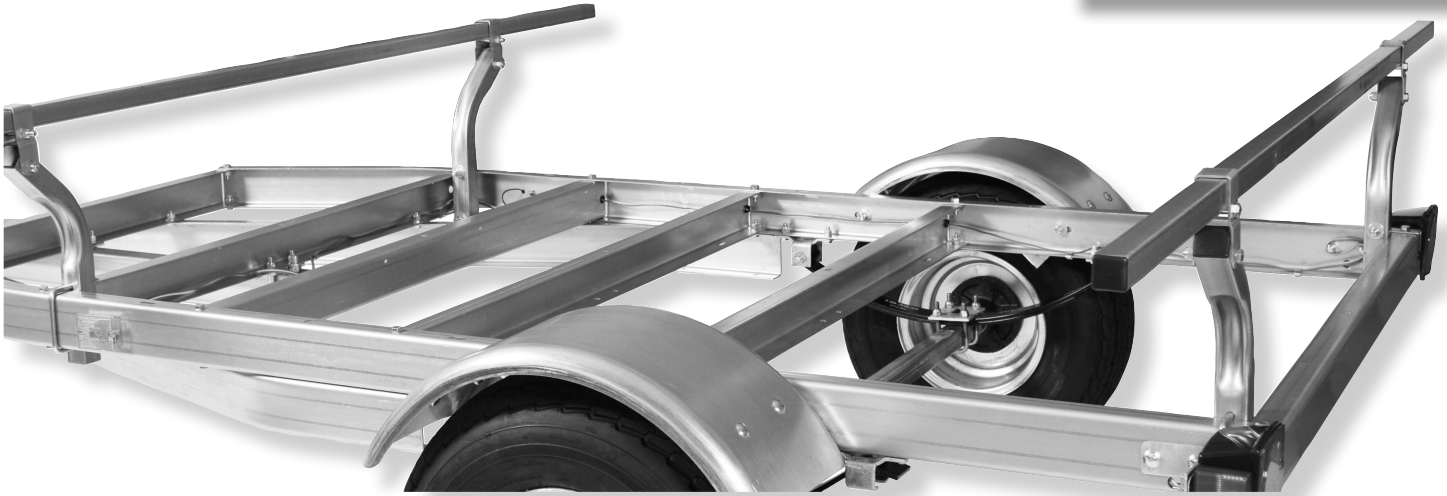

7). Install the D-Rings to the ends of the load bars. Slide a nylon lock nut into the open end of the load bar and align with the hole. Place washer under bolt head and insert it through the D-ring.

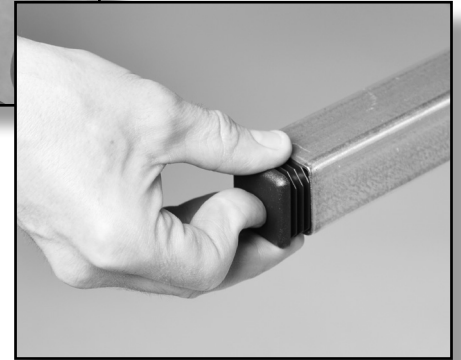
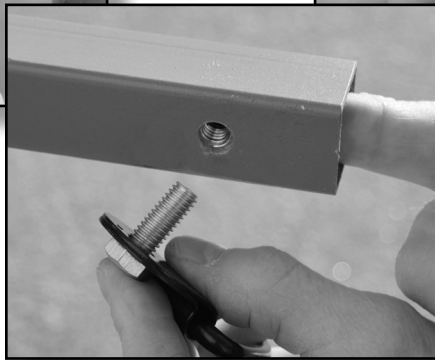
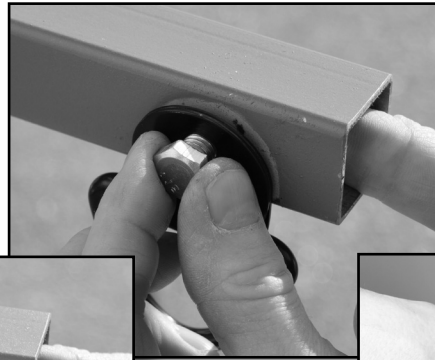
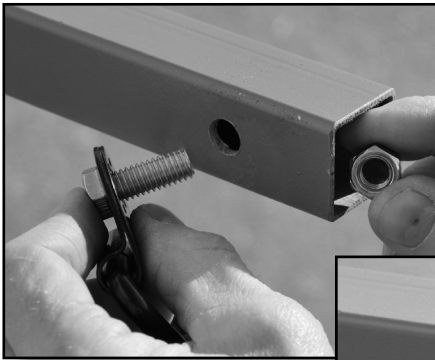

8). Align the bolt to the nut inside the cross bar and hand tighten. To secure fully, use a 9/16" wrench inside the cross bar to capture the nut inside. A 9/16" socket is used on the bolt head. Complete the cross bars with the new end caps. Repeat for remaining D-rings and end caps.

## JACK STAND (Group 7)

Measure and mount the Jack Stand approximately 24" back from the front of the coupler.



Rotating the handle will raise and lower the coupler unit accordingly, making for a quick and easy install to the vehicles trailer ball.



Pull the release lever to fold the Jack stand up and out of the way during transport. It can be rotated towards the front or rear.



8. **Go back** now and **re-check** that **all nuts and bolts on the ENTIRE trailer** are securely tightened.



**PLEASE REFERENCE YOUR RED ENVELOPE**

**WHEN YOU RECEIVE YOUR TIRE LOADING DECAL**, please apply as shown on the drivers side of the tongue. Be sure to clean the frame before applying the decal.

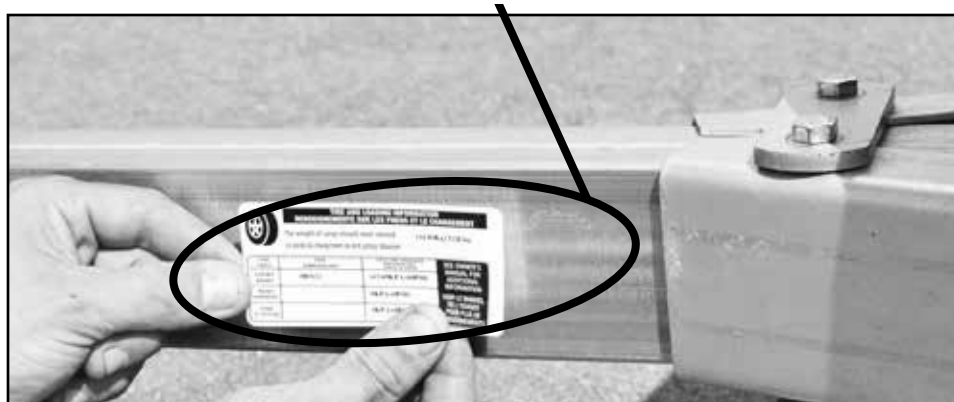

**Your MegaSport™ Trailer is now complete and ready to register and title !  
Contact your local DMV office for specific procedures in your State.**

**\*THINK YOU MAY HAVE A LEAKING HUB?**

It has been noted that on the first few trips the excess grease can work its way the back side of the hub, making a mess on the wheel. We have confirmed with CE Smith, to whom we sent an axle showing this issue in the past, that there is no concern with the hub or seals at all. It is simply an over packed hub, no damage to any parts within. We have seen this several times over the years but felt we may have misdiagnosed the problem. We did not and it is not a problem at all. If this incident occurs, it is not a cause to worry. Again, as we have always stated, CE Smith packs those hubs full of grease to ensure no initial maintenance is needed. Both Malone and CE Smith stand behind this.

We also received feedback from another consumer to whom we passed this information onto:  
“I figured this might be the situation as during a 1,200 mile drive to Colorado the hubs never overheated. I checked them every stop with an infrared thermometer. “

If you have any further questions please don't hesitate to ask.

Visit us at ***maloneautoracks.com***  
for more fine products and accessories.

# **MALONE**<sup>®</sup>

## **CHANGING THE WAY YOU GET THERE**

### **Limited Five (5) Year Warranty**

The Malone Auto Racks (Malone) Limited 5 Year Warranty covers certain Malone-brand products that have been specifically identified for inclusion in the program. This warranty is in effect for five (5) years, from the time of sale, for the original retail purchaser of the product. This warranty is terminated after five years from the date of purchase, or, when the original retail purchaser sells or otherwise transfers the product to any other person or entity during the five year warranty period.

Subject to the limitations and exclusions described in this warranty, Malone will remedy defects in materials and/or workmanship by repairing or replacing, at its option, a defective product without charge for parts or labor. Malone may elect, at its option, not to repair or replace a defective product but rather issue to the original retail purchaser a refund equal to the purchase price paid for the product, or credit to be used toward the purchase of a replacement Malone product.

This warranty does not cover, and no warranty is given for defects or problems caused by normal wear and tear, which includes, but is not limited to, surface (aesthetic) metal corrosion, scratches, dents, deformities, accidents, unlawful vehicle operation, or any modification of a product not performed or authorized in writing by Malone.

In addition, this warranty does not cover problems resulting from conditions beyond Malone's control including, but not limited to, theft, misuse, overloading, or failure to assemble, mount or use the product in accordance with Malone's written instructions or guidelines included with the product provided to the original retail purchaser.

No warranty is given for Malone products purchased outside of the continental United States, Canada and Mexico.

If the product is believed to be defective, the original retail purchaser should contact the Malone dealer from whom it was purchased, who will give the original retail purchaser instructions on how to proceed. If the original retail purchaser is unable to contact the Malone dealer, or the dealer is not able to remedy the defect, the original retail purchaser should contact Malone by email at [support@maloneautoracks.com](mailto:support@maloneautoracks.com).

In the event that the product must be returned to Malone, a technician at the email address above will provide the original purchaser with return shipping instructions. The original purchaser will be responsible for the cost of mailing the product to Malone. In order to be eligible to receive any remedy under this warranty, a copy of the original purchase receipt, a description of the defect and a return address must be provided.

### **Disclaimer of Liability**

Repair or replacement of a defective product, or the issue of a refund or credit (as determined by Malone) is the original retail purchaser's sole and exclusive remedy under this warranty. Damage to original purchaser's vehicle, cargo, or property, and/ or to any other person or property is not covered by this warranty.

This warranty is expressly made in lieu of any and all other warranties, express or implied, including the warranties of merchantability and fitness of a particular purpose

Malone's sole liability to any purchaser is limited to the remedy set forth above. In no event will Malone be liable for any direct, indirect, consequential, incidental, special, exemplary, or punitive damages , or, for any other damages of any kind or nature (including but not limited to, lost profits, lost income or lost sales).

Some states do not allow the exclusion or limitation of incidental or consequential damages, so the above limitations may not be applicable.

In addition, all vehicular transports are potentially hazardous. Any person(s) using Malone products are personally responsible for following the given directions for use and/or installation and accepts full responsibility for any and all damages or injury of any kind including death, which may result from their use and/or installation.