

BE POWER[®] EQUIPMENT

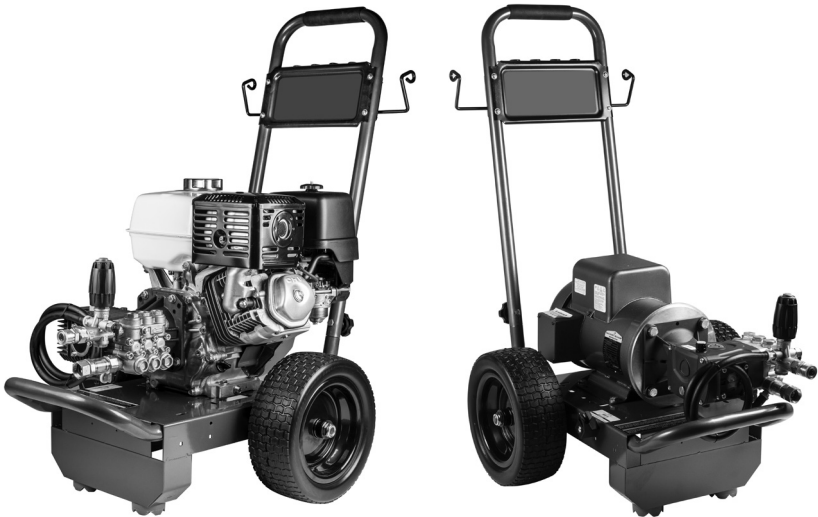

PRESSURE WASHER OPERATOR'S MANUAL

MANUEL D'UTILISATION DU LAVEUSES À PRESSION
MANUAL DEL OPERADOR DE LA LAVADORA A PRESIÓN

BEPOWEREQUIPMENT

.COM

02-2026
85.609.006



WARNING – LIMITATION OF LIABILITY

Use of this equipment is at the operator's sole risk.

BE Power Equipment shall not be held responsible for any personal injury, property damage, or economic loss resulting from:

Improper use or maintenance

Unauthorized modifications

Failure to follow safety instructions or operating guidelines

Use of the product beyond intended or specified purposes

In the event of equipment failure or manufacturer defect, BE Power Equipment's liability is strictly limited to repair or replacement of the product under warranty, if applicable. In no case shall BE Power Equipment, its distributors, or affiliates be liable for incidental, indirect, or consequential damages of any kind, to the extent permitted by law.

ALWAYS read and follow all safety instructions and manuals before operation. Improper use can result in serious injury or damage.

By using this product, you accept these terms.



INTRODUCTION	4
SAFETY OVERVIEW	5
PRESSURE WASHER COOLING SYSTEM	10
FUEL AND OIL TYPES	11
COMPONENT DIAGRAMS GAS PRESSURE WASHERS	12
COMPONENT DIAGRAMS ELECTRIC PRESSURE WASHERS	16
ASSEMBLY	18
PRE-OPERATION	20
GAS ENGINE START PROCEDURE	21
GAS ENGINE STOP PROCEDURE	24
ELECTRIC MOTORS WITH AUTO STOP-START SYSTEM	25
ELECTRIC MOTOR STOP PROCEDURE	25
CLEANING WITH DETERGENTS	26
STORAGE	27
MAINTENANCE	28
TROUBLESHOOTING	30
WARRANTY	34

Congratulations on your purchase of a BE Power Equipment pressure washer. You can be confident that this machine is constructed and tested with optimum performance and quality in mind.

Reading this manual will help get you the best results for set-up, operation, maintenance and avoid personal injury or damage to your machine. By knowing how best to operate this machine, you will be better positioned to show others who may also operate the unit.

All the information in this manual is based on the latest product information available at the time of printing. BE Power Equipment reserves the right to make changes at any time without notice or incurring any obligation.

Owner/Operator Responsibility

The owner/operator must have a thorough understanding of the operation, maintenance and dangers associated with using this machine. It must be understood that it is ultimately up to the owner/operator to safely use this machine as outlined in this manual.

This manual is considered a part of the machine and needs to be kept in a safe location. If the machine is resold or given to someone else, this manual needs to be included.

Product Registration

Please register your product online to get the maximum benefit from your warranty. Use the QR code below or register online at: bepowerequipment.com/product-registration



It is recommended that you record the product identification numbers in this manual. These numbers are important to have on hand if you need to contact technical support (1-866-850-6662). The model and serial number can be found on the box and on decal on the machine.

PRODUCT IDENTIFICATION

Model Number: _____

Serial Number: _____

Date of Purchase: _____

Dealer Name: _____

SAVE THESE INSTRUCTIONS - SAFETY RULES



This is the safety alert symbol. It is used to alert you to potential personal injury hazards. Obey all safety messages that follow this symbol to avoid possible injury or death.

The safety alert symbol (▲) is used with a signal word (**DANGER, CAUTION, WARNING**), a pictorial and a safety message to alert you to hazards.

DANGER indicates a hazard that, if not avoided, will result in death or serious injury.

WARNING indicates a hazard that, if not avoided, could result in death or serious injury.

CAUTION indicates a hazard that, if not avoided, might result in minor or moderate injury.

NOTICE indicates a situation that could result in equipment or property damage.

IMPORTANT SAFETY INSTRUCTIONS - SAVE THESE INSTRUCTIONS

WARNING – When using this product, the following precautions should always be observed and adhered to.

1. Read all instructions before using the product.
2. To reduce the risk of injury, close supervision is necessary when a product is used near children.
3. Know how to stop the product and bleed pressures quickly. Be thoroughly familiar with the controls.
4. Stay alert. Watch what you are doing.
5. Do not operate the product when fatigued or under the influence of alcohol or drugs.
6. Keep operating area clear of other people.
7. Do not overreach or stand on unstable support. Instead, keep solid footing and balance at all times.
8. Follow the maintenance instructions specified in the manual.

IMPORTANT WARNINGS

Failure to observe warnings will void the warranty or cause injury.

1. Do not let the pressure washer overheat. Excess heat will cause serious damage (see page 10 for details).
2. Never run the unit without water. Running the pump dry will cause it to fail quickly.
3. Do not let the unit freeze. Frozen water in the pump will cause severe damage.
4. Always wear eye protection when operating the unit.
5. High-pressure spray can cause serious bodily injury or damage to soft material. Use with caution.
6. Never adjust the unloader to exceed the preset pressure. Premature wear, equipment failure, or injury may occur.

PERSONAL SAFETY

⚠ WARNING - Always wear correct personal protection equipment because the high-pressure spray can launch debris at high velocity creating a risk of injury or damage.

- **ALWAYS** wear safety goggles for eye protection. Other protective equipment such as hearing protection, steel toe boots, safety apparel, work gloves and face shield are all recommended.
- **NEVER** pressure wash without closed-toe foot protection in case of accidental spray.
- **ALWAYS** be aware of where the spray gun is pointing and your environment
- **NEVER** point it at people or animals.
- **DO NOT** let children or unqualified people operate this machine.
- **DO NOT** use the machine when fatigued or under the influence of alcohol or drugs.

GENERAL PRESSURE WASHER SAFETY

⚠ DANGER – High-Pressure Spray

- **NEVER** point the gun at yourself, anyone else, or animals.
- The high-pressure water stream can cut through clothing, skin and underlying tissues leading to serious injury.
- If this type of injury occurs, **DO NOT TREAT AS A SIMPLE CUT. SEEK EMERGENCY MEDICAL ATTENTION IMMEDIATELY.** If you are using cleaning detergents, be prepared to tell the physician exactly what kind.
- Spray guns can have significant kickback. **ALWAYS** brace yourself and have firm footing when operating.
- **NEVER** attempt to repair high-pressure hose, fittings or gun. Always replace parts if they are leaking or damaged.
- **NEVER** bypass the trigger assembly. This is an important safety feature of the system.
- **NEVER** leave a running machine unattended.
- Use **CAUTION** even when the machine has been turned off. Pressure can be trapped in the pump and hose assembly and still inflict injury or damage. After turning the machine off, always squeeze the trigger to release any trapped pressure.
- **ALWAYS** ensure all component connections and fittings are securely fastened. High-pressure water can turn loose fittings or spray nozzles into projectiles causing injury or damage.
- **NEVER** look directly into the gun or high-pressure hose.
- **NEVER** place your hand in front of the spray nozzle to test pressure.

⚠ DANGER – ELECTROCUTION

- **NEVER** spray near electric power source or cords.
- **NEVER** let run-off water pool and flow into power sources or cords.

⚠ WARNING – GENERAL SAFETY

- **ONLY** use cold water to feed into the machine. Unless specifically instructed that the machine can use hot water.
- Check the work area to make sure it is clear of hazards and debris which can be thrown by pressure spray causing injuries or damage.
- **ALWAYS** be aware of surfaces that will become wet and may become slippery.
- **ALWAYS** have a secure grip of the gun and stable footing.

- **ALWAYS** ensure proper drainage to avoid water flooding into unwanted areas.
- **NEVER** operate machinery that is damaged or missing components.
- **NEVER** modify the machine in any way.
- **DO NOT** move the machine by pulling on the hoses or cords. Instead, use the handle on the frame to move the machine when needed.
- Use **CAUTION** when spraying soft materials such as plants or wood because the high-pressure spray can damage them quickly.
- Use **CAUTION** when spraying brittle materials such as glass, that may break apart, creating dangerous projectiles.
- Use only recommended accessories. **DO NOT** force or modify parts to fit.
- **ALWAYS** turn off the engine and disconnect the spark plug for any maintenance procedures.
- **NEVER** attempt to maintain the machine while it is operating. Moving parts and pressure can cause serious injuries.
- Keep machine out of the rain and elements.
- **ALWAYS** operate the machine on a level surface. It may seize if operated at an angle.

⚠ WARNING – CHEMICAL DETERGENTS/SOAPS

- **ALWAYS** use detergents explicitly designed for a pressure washer.
- **NEVER** use any flammable, corrosive or acidic solutions.
- **NEVER** modify the chemical injector system.
- **ALWAYS** flush the system after using a detergent. Run the machine for at least two minutes with clean water to prevent detergent from drying and building up residue. If residue builds up, it may cause the chemical injector system to fail.
- **ALWAYS BE PREPARED** for an emergency involving detergents. Know exactly what the detergent contains. If an emergency occurs and a physician needs this information, Safety Data Sheets (**SDS**) are available and should be easily accessible.
- **ALWAYS** keep detergents away from children and animals.
- Keep an eyewash kit available in case of emergency.

GAS ENGINE SAFETY

If your pressure washer has a gas engine, the engine will have its own manual. Thoroughly review and understand the engine manual.

⚠ DANGER – TOXIC FUMES

- **ALWAYS** operate the machine outdoors in well-ventilated spaces.
- The emissions from the engine include the poisonous gas carbon monoxide. It is a colorless, odorless gas that will displace oxygen and be lethal in high enough concentrations.
- Symptoms of carbon monoxide poisoning include headache, fatigue, dizziness, nausea, confusion, vomiting, and seizures. If poisoning continues, unconsciousness and death will occur.
- At the first sign of any symptoms, **IMMEDIATELY** shut off the machine and move into a well-ventilated area and seek medical attention.
- Carbon monoxide is heavier than atmospheric air and will fill in low spaces first. Use **EXTREME CAUTION** when operating in low spaces such as trenches, tunnels or ditches.
- **NEVER** position the machine where the exhaust can go through windows, doors, ventilation or other access points that lead indoors or to confined areas.
- **NEVER** use a respirator as protection against carbon monoxide. The **ONLY** protection that can be relied on is a positive pressure fresh air supply system, such as a SCUBA system.

⚠ DANGER – FUEL RELATED FIRE AND EXPLOSIONS

- Fuel and its vapors are highly flammable and explosive.
- Fire and explosion can cause severe burns and death.
- **NEVER** fill the fuel tank while the unit is running.
- **ALWAYS** turn the engine off and let it cool at least two minutes before removing fuel cap. Loosen the fuel cap slowly to relieve tank pressure.
- **ALWAYS** fill or drain the fuel tank outdoors.
- **DO NOT** overfill the tank. Leave an airspace in the neck of the fuel tank to allow it to breathe and for fuel expansion.
- **NEVER** have any spark or flame near the fuel, including cigarettes, open flame, pilot lights and other ignition sources.
- If fuel spills, wait until it evaporates completely. Move the unit to a new location, then wait at least two minutes before starting the engine.
- **NEVER** crank the engine with the spark plug removed and still in its boot.
- When transporting or putting the unit into storage, drain the fuel tank and carburetor and store the fuel in an airtight container. Then, move the fuel valve into the closed position.
- Never store fuel near any ignition source or hot surface.

⚠ CAUTION – HOT SURFACES

- The muffler on the engine will heat up rapidly and can cause severe burns if touched.
- Muffler exhaust will be hot and can cause burns to people and objects.
- Keep flammables away from the muffler.
- Keep at least a five-foot clearance from the exhaust to prevent damaging other surfaces such as house siding and vehicles.
- The pump will also become hot during operation and should be avoided.
- After the pressure washer has been started, **DO NOT** touch any part of the pressure washer other than the on/off switch, handle, hose and gun.

⚠ CAUTION – RECOIL KICKBACK

- Starter cord kickback (rapid retraction) can result in bodily injury.
- Kickback can pull your hand and arm back towards the engine faster than you can let go causing sprains, cuts, bruising and bone fractures.
- **NEVER** pull the starter cord without first relieving the spray gun pressure.
- When starting an engine, the best practice is to have the trigger squeezed to prevent pressure from building up in the system.
- Pull the starter cord until you feel resistance. Allow the cord to retract back and then pull the starter to avoid kickback and injury.

ELECTRIC PRESSURE WASHER SAFETY**⚠ DANGER – RISK OF ELECTROCUTION**

- **NEVER** spray an electric pressure washer, its cord, or power source.
- **NEVER** leave the machine exposed to rain or the elements.
- **NEVER** modify the plug or cord.
- **NEVER** use an adapter so the plug will fit into a different outlet.
- **NEVER** touch the cord or plug with wet hands or when standing in water.
- **ALWAYS** replace damaged components, including plug and cord. **DO NOT** attempt to repair.
- **ALWAYS** ensure power source matches the pressure washers' requirements.
- **ALWAYS** use a licensed electrician if any electrical work needs to be done.
- **ALWAYS** unplug the motor from the power source before attempting repairs or maintenance.

⚠ DANGER – GROUNDING

- This product must be grounded. If this machine malfunctions, grounding provides a path of least resistance for electric current, reducing the risk of electrocution.
- Ensure the plug has all three prongs it came with and is plugged into an appropriate outlet that is grounded in accordance with local regulations.



- If your machine is equipped with a Ground Fault Circuit Interrupter (GFCI), **DO NOT** remove or alter it. Replace if damaged.
- If the GFCI is dropped or damaged, be certain to test it to make sure it is still working correctly.

⚠ WARNING – EXTENSION CORDS

- The use of extension cords is not recommended.
- If the use of an extension cord is unavoidable, then it must be plugged into a GFCI found in circuit boxes or protected receptacles
- **ALWAYS** use a 3-wire extension cord that has three prongs for proper grounding.
- **DO NOT** yank or pull on extension cords.
- **ALWAYS** replace if damaged.
- The extension cord gauge **MUST** be adequate for the power demands of the pressure washer to prevent stalling, overheating or short-circuiting.

⚠ BATTERY – WHERE APPLICABLE

- **NEVER** use a battery that is cracked or shows other signs of visible damage.
- **ALWAYS** connect positive lead to positive terminal, and negative lead to negative terminal. **NEVER** cross-wire.
- The engine is equipped with an alternator and will charge the battery during operation. If recharging battery with an auxiliary charger it is your responsibility to use the appropriate equipment and settings.
- **NEVER** operate when battery is wet. Avoid contact with water when not in use.
- Do not tamper with battery, alter it anyway, or try to open it up.

DO NOT OVERHEAT YOUR MACHINE

Do not let your machine overheat. Failure to do so will result in damage, void warranty, or cause injury.

Gas engines and electric motors are air-cooled. Always ensure that the machine is operated in a well-ventilated area where it can draw a steady supply of fresh air. If the motor overheats, it may shut down, rapidly burn oil, and result in component failure. The arrows below show an example of locations for air intake on an engine.

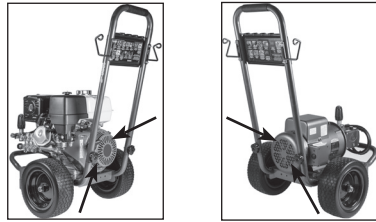

Pumps are cooled on the front end by having fresh water run into the pump, then spray out of the gun wand. To maintain the water flow, keep the trigger of the gun depressed to keep spraying out water. Do not let the machine run for more than 30 seconds without pressing down on the trigger. If the pump is left to overheat (not spraying water), it may experience thermal shock when cold water is introduced to the system once water is sprayed out again. This thermal shock can result in multiple component failures.

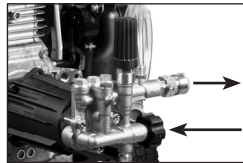

Axial Pump

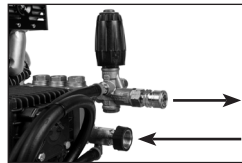

Triplex Pump

Most pumps are protected by a thermal valve. The thermal valve releases water if a pump starts to run too hot. It will prevent catastrophic heat failure. However, the pump may have suffered damage and need maintenance, repair, or replacement. The thermal valve will need to be replaced once it is triggered.

The back end of the pump is cooled by maintaining the proper level and quality of pump oil. Always check the oil level on the back of the pump by using the dipstick or sight gauge. Use 30w non-detergent oil if it needs to be added or replaced.

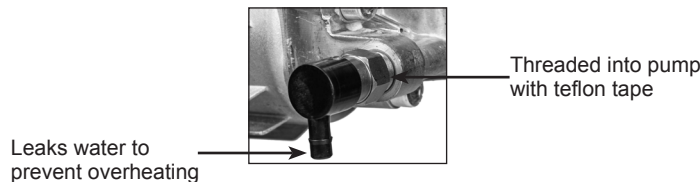

FUEL AND OIL TYPES

ENGINE FUEL TYPE

Use only regular unleaded gasoline rated at 86 octane or higher. The best fuel to use will have a 0% ethanol blend. However, the engine can use a fuel with an ethanol blend of up to 10%.

ENGINE OIL TYPE

Use only SAE 10W30 motor oil for the engine. To check the oil, unscrew the engine dipstick. Then, wipe off the oil with a clean rag and dip it back into the engine. The oil should be well within the oil level markings.

Note* the engine will have two oil caps. Only one will have a dipstick.

ENGINE TYPE	FUEL TANK CAPACITY	OIL CAPACITY
Powerease 212	3.6 L / 0.95 US Gal	0.6 L / 0.63 US qt
Powerease 225	3.6 L / 0.95 US Gal	0.6 L / 0.63 US qt
Powerease 420	6.7 L / 1.7 US Gal	1.1 L / 1.16 US qt
Kohler SH270	3.3 L / 0.87 US Gal	0.6 L / 0.63 US qt
Kohler CH440	7.0 L / 1.85 US Gal	1.3 L / 1.4 US qt
Honda GC160	1.8 L / 0.48 US Gal	0.58 L / 0.61 US qt
Honda GC190	1.8 L / 0.48 US Gal	0.58 L / 0.61 US qt
Honda GX200	3.1 L / 0.82 US Gal	0.6 L / 0.63 US qt
Honda GX270	5.3 L / 1.4 US Gal	1.1 L / 1.16 US qt
Honda GX390	6.1 L / 1.6 US Gal	1.1 L / 1.16 US qt
Honda GX690	N/A	2.0 L / 2.1 US qt
Vanguard 200	3.1 L / 0.82 US Gal	0.59 L / 0.6 US qt
Vanguard 400	5.7 L / 1.5 US Gal	0.94 L / 1.0 US qt

PUMP OIL TYPE

For pressure washer pumps, use only SAE 30W non-detergent oil. Never use motor oil in your pressure washer pump because it will destroy the seals. Never overfill the pump.

- If your pump has a sight glass, then fill halfway up to the middle of the red dot.
- If your pump has a dipstick, then fill to the mark on the dipstick.
- If your pump doesn't have a sight glass or dipstick, then it is a sealed unit, and the owner doesn't have to be concerned with maintaining the pump oil.

The following diagrams are intended for general reference.

Your pressure washer may differ from the models shown in the following pages. For specific model information, please visit bepowerequipment.com

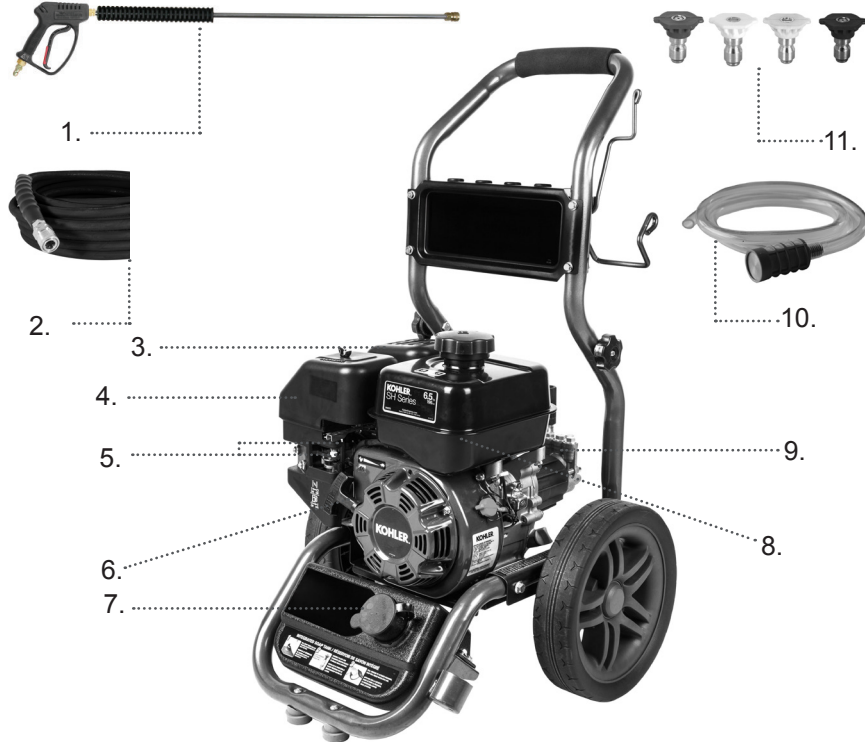

1. **Split Lance Spray Gun**
2. **High-pressure Hose to the outlet. Connections vary by model.**
3. **Muffler/Exhaust** - Reduces noise of the engine and expels heat.
4. **Air Filter housing**
5. **(Above) Choke rod** - Prepares a cold engine for starting.
(Down) Throttle Lever - Controls engine RPM speed.
6. **Recoil Starter** - Used to manually start the engine.
7. **Soap Tank:** (not included on all models) Fill with pressure washer detergent only.
8. **Pump:** develops high pressure. Connect the garden hose to the water pump inlet and connect the high pressure hose to the outlet. Connections vary by model.
9. **Gas tank**
10. **Detergent suction hose:** used to draw detergent into the low pressure stream.
11. **Spray nozzles:** 0°, 15°, 40° Detergent: For various cleaning applications.



1. **Spray Gun** - Controls the application of water onto the cleaning surface with a trigger device. Includes trigger lock. Allows you to switch between various spray nozzles.
2. **Spray Nozzles** - 0°, 15°, 40° and Detergent: for various high-pressure cleaning applications.
3. **High-Pressure Hose** - Designed to withstand the pressure generated by the pump.
4. **Unloader** - Pressure is preset at the factory.
5. **Pump** - Develops high pressure. Connect the garden hose to the inlet of the water pump, and connect the high-pressure hose to the outlet.
6. **Oil Level Indicator** - Level should be at halfway (not included for all models).
7. **Detergent Siphoning Hose** - Use to siphon pressure washer-safe detergent into the low-pressure stream.
8. **Fuel Tank** - Fill tank with regular unleaded fuel. Always leave room for fuel expansion.
9. **Air Filter** - Protects engine by filtering dust and debris out of the intake air.
10. **Throttle Lever** - Controls RPM speed of engine.
11. **(Top) Choke Lever** - Prepares a cold engine for starting.
(Bottom) Fuel Valve - Used to turn fuel supply on and off to the engine.
12. **Recoil Starter** - Used for starting the engine manually.
13. **Engine Switch** - Set switch to "On" for recoil starting. Set switch to "Off" to stop a running engine.

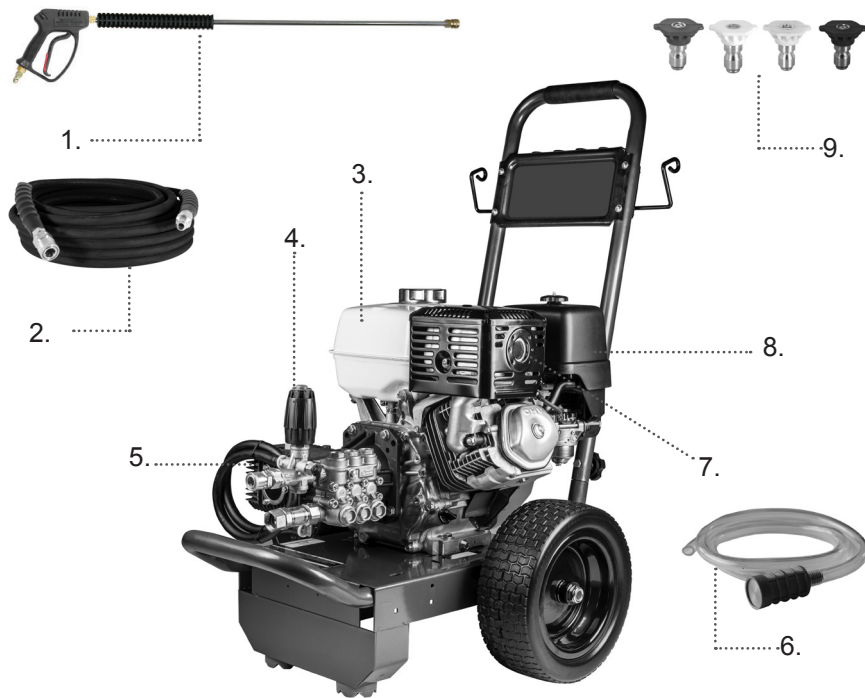

1. **Spray Gun** - Controls the application of water onto the cleaning surface with a trigger device. Includes trigger lock. Allows you to switch between various spray nozzles.
2. **High-Pressure Hose** - Designed to withstand the pressure created by the pump.
3. **Fuel Tank** - Fill tank with regular, unleaded fuel. Always leave room for fuel expansion.
4. **Unloader** - Pressure is preset from the factory.
5. **Pump** - Develops high-pressure. Connect the garden hose to the inlet of the water pump, and connect the high-pressure hose to the outlet. Connections vary by model.
6. **Detergent Siphoning Hose** - Used to draw detergent into the low-pressure stream.
7. **Muffler/Exhaust** - Reduces noise of the engine and expels heat.
8. **Air Filter** - Protects engine by filtering dust and debris out of the intake air.
9. **Spray Nozzles** - 0°, 15°, 40° and Detergent: for various cleaning applications.

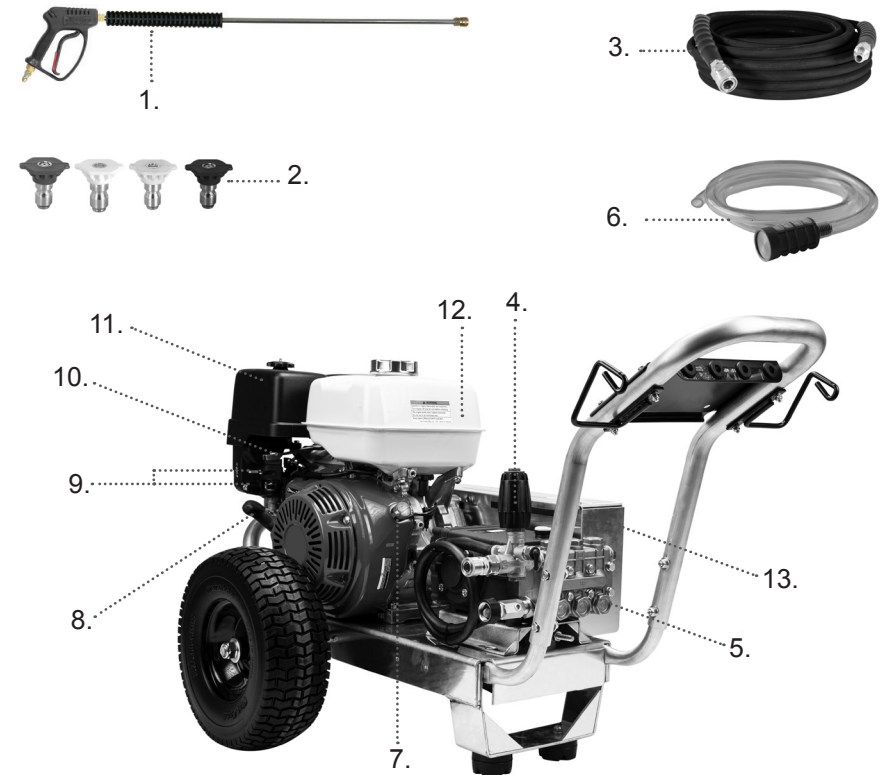

1. **Spray Gun** - Controls the application of water onto the cleaning surface with a trigger device. Includes trigger lock. Allows you to switch between various spray nozzles.
2. **Spray Nozzles** - 0°, 15°, 40° and Detergent: for various high-pressure cleaning applications.
3. **High-Pressure Hose** - Designed to withstand the pressure generated by the pump.
4. **Unloader** - Pressure is preset from the factory.
5. **Pump** - Develops high pressure. Connect the garden hose to the inlet of the water pump, and connect the high-pressure hose to the outlet.
6. **Detergent Siphoning Hose** - Use to siphon detergent into the low-pressure stream.
7. **Engine Switch** - Set switch to "On" for recoil starting. Set switch to "Off" to stop a running engine.
8. **Recoil Starter** - Used for starting the engine manually.
9. **(Top) Choke Lever** - Prepares a cold engine for starting.
(Bottom) Fuel Valve - Used to turn fuel supply on and off to the engine.
10. **Throttle Lever** - Controls RPM speed of engine.
11. **Air Filter** - Protects engine by filtering dust and debris out of the intake air.
12. **Fuel Tank** - Fill tank with regular unleaded fuel. Always leave room for fuel expansion.
13. **Belt Drive Cover** - Shields the belt and pulley drive system.

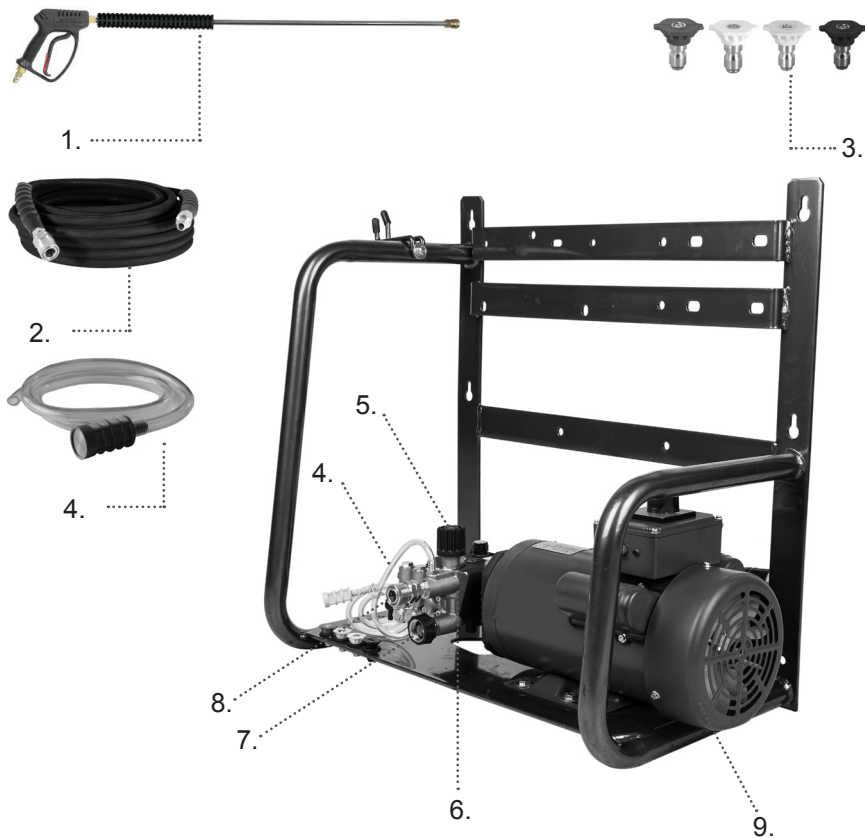

1. **Spray Gun** - Controls the application of water onto the cleaning surface with a trigger device. Includes trigger lock. Allows you to switch between various spray nozzles.
2. **High Pressure Hose** - Designed to withstand the pressure created by the pump.
3. **Spray Nozzles** - 0°, 15°, 40° and Detergent: for various cleaning applications.
4. **Detergent Siphoning Hose** - Used to draw detergent into the low-pressure stream.
5. **Unloader** - Pressure is preset from the factory.
6. **Pump** - Develops high pressure. Connect the garden hose to the inlet of the water pump, and connect the high-pressure hose to the outlet. Connections vary by model.
7. **Inlet** - Connection for the water source such as a garden hose.
8. **Outlet** - Connection for the high-pressure hose.
9. **Motor** - Power source that spins the pump



1. **Spray Gun** - Controls the application of water onto the cleaning surface with a trigger device. Includes trigger lock. Allows you to switch between various spray nozzles.
2. **High Pressure Hose** - Designed to withstand the pressure created by the pump.
3. **Spray Nozzles** - 0°, 15°, 40° and Detergent: for various cleaning applications.
4. **Detergent Siphoning Hose** - Used to draw detergent into the low-pressure stream.
5. **Unloader** - Pressure is preset from the factory.
6. **Pump** - Develops high pressure. Connect the garden hose to the inlet of the water pump, and connect the high-pressure hose to the outlet. Connections vary by model.
7. **Inlet** - Connection for the water source such as a garden hose.
8. **Outlet** - Connection for the high-pressure hose.
9. **Motor** - Power source that spins the pump

Your pressure washer will require some assembly. If you have any trouble with this process, please call our tech support department (1-866-850-6662) with your model number.

Unpack your pressure washer

- Remove all the components, including bags and manuals.
- Inspect components to make sure there is no visible damage.

ATTACH HANDLE

1. Remove any plastic coverings that may be on the handle. Place handle (A) onto handle supports (B) connected to the frame. Make sure holes (C) in handle align to the holes on the frame supports.

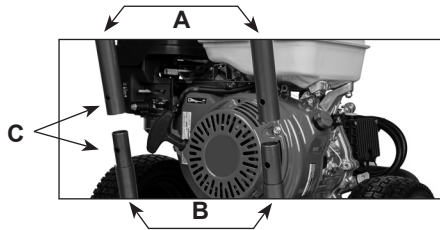

NOTE: These diagrams are intended for general reference. As a result, they may not fully reflect the appearance of your product.

2. Insert the bolts through holes. The carriage bolts will have hex heads that need to be matched to the side of the handles with a hex shaped hole pattern to help secure them.



3. Insert colored quick connect spray nozzles, high-pressure hose, gun wand assembly into the spaces provided.



4. If needed, attach the provided detergent siphoning hose to brass barb coming out of the pump near the high-pressure outlet. (Do not attach to the black plastic thermal relief valve barb.)

5. Assemble the gun wand. The trigger assembly will be threaded onto the wand. Hand tighten only.

HOSE CONNECTIONS

- **Quick connect fittings:** pull back the collar of the coupler, insert plug, and release the collar. Tug on fittings to confirm a secure lock.
- **M22 Fittings:** Line up the insert and thread together so it is hand tight. Do not overtighten.
- **Spray Nozzles:** To attach a spray nozzle to the end of the wand, pull back on the collar of the brass fitting. Insert the spray nozzle and release the collar. Tug on the nozzle to make sure it is secure. If it is loose, the high-pressure water will launch it out and may cause injury or damage.

Your pressure washer will come with several colored spray nozzles that will have different spray patterns and abilities.

0° Nozzle (Red)	Concentrated stream to break apart baked-on mud or dirt. Use with caution.
15° Nozzle (Yellow)	Narrow spray pattern that is aggressive and best used on hard surface to remove tough dirt.
25° Nozzle (Green)	General purpose spray pattern. Slightly wider, but still fairly aggressive.
40° Nozzle (White)	Wider spray pattern for large areas or softer surfaces.
Black Soaper Nozzle	Low pressure nozzle. This is the only nozzle that can be used with the chemical injector system.

1. Before operating the pressure washer, ensure you are familiar with all the warnings and safety recommendations.
2. Wear proper clothing and eye protection.
3. Always setup the machine where:
 - 3.1 It is on a level surface. If the machine is not level, it may not start or cause failures.
 - 3.2 There is sufficient ventilation.
 - 3.3 There are no signs of oil or gas leaks, including gas vapors.
 - 3.4 The machine is not exposed to rain, snow or freezing temperatures. These harsh conditions can lead to component failure causing damage or injury.
4. Ensure that oil levels for the engine and pump are correct.
 - 4.1 Use 10W30 oil to fill the engine if needed.
 - 4.2 Use 30W non-detergent oil to fill the pump if needed.
5. If the pump has an oil cap dipstick, make sure it is the breathing oil cap instead of the sealed travel oil cap. If the sealed travel oil cap is left in, the pump will over pressurize and blow it out.
6. Inspect the overall condition of the unit. Make sure there are no fuel or oil leaks or damaged parts. If any leaks or damaged parts are detected DO NOT start the pressure washer until it is fixed.
7. Connect the high-pressure hose to the pump and the gun wand assembly to the other end of the hose.
8. Connect the garden hose to the pump.
 - 8.1 Ensure the inlet filter on the pump is present, intact, and clean before connecting the garden hose.

WATER SUPPLY MUST BE SUFFICIENT TO SUPPLY THE PUMP ADEQUATELY.

Every pressure washer has a Gallons Per Minute (GPM)/ Liters Per Minute (LPM) rating that must be adhered to. If the pump does not get enough water, it will cavitate (starve for water). This will cause internal damage and pending failure.

To measure your water source GPM/ LPM, you will need a container that you know the exact size such as a 5-gallon/20-Liter bucket. When you're ready, start filling it from your water source while timing it for one minute. The amount of water in the 5-gallon/20-liter bucket after one minute is the GPM/LPM rating.

The water source GPM/ LPM should exceed the GPM/ LPM rating of the machine by one GPM/ LPM to account for any fluctuations from the water source.

The water source should have 20 to 60 PSI/1.38 to 4.1 BAR pressure going into the pump. Do not use a hose longer than 50ft/15m to the water source.

PRIME THE PUMP WITH WATER

Once all the hoses are connected, turn on your water supply and hold down the spray gun's trigger. Let water flow through it until all the air bubbles are worked through, and there is a constant stream of water coming out the nozzle.

Insert the color spray nozzle that you plan to use. Make sure the nozzle is clean with no damage or blockages.

1. Fill the fuel tank with gasoline. Use regular unleaded, 86 octane or higher that has no more than 10% ethanol blend.
2. Do not overfill the fuel tank. Always leave a space to allow the tank to breathe and the fuel to expand.
3. If your unit's engine is equipped with a throttle, set it to full throttle. The lever should be all the way to the LEFT on all models, except for the Honda GC, where it should be all the way UP. **Please skip this step if you unit's engine is not equipped with a throttle.**
4. Turn the fuel valve to the ON position which is all the way to the RIGHT on all models except the Vanguard and Honda GC which do not have a separate fuel valve.
5. Activate the choke if the engine is cold. Move the choke lever to the LEFT on all models except the Honda GC where the choke tab is pulled OUT.

- HONDA GX
- POWEREASE
- KOHLER SH270



- HONDA GC

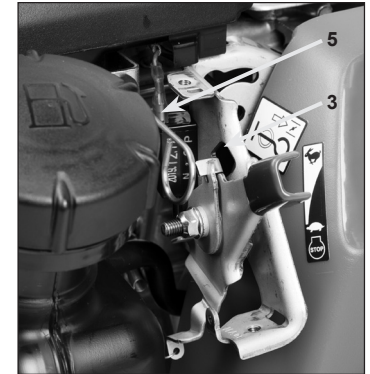

- KOHLER CH440



- VANGUARD



6. Put engine switch to the **ON** position. On the Honda GX, Powerease, and Kohler SH270 engines it will be switch on the side of the engine like the picture below. The Kohler CH440 has the ON/OFF built into the fuel valve.

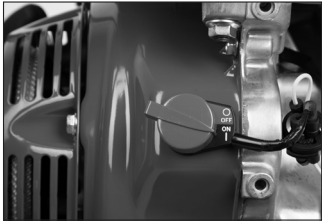

- HONDA GX
- POWEREASE
- KOHLER SH270

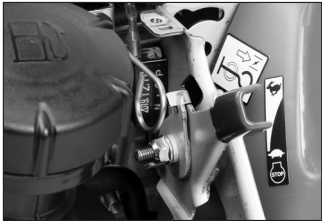

Honda GC engine: Move throttle all the way up to put in ON position.



Kohler CH440 engine: Move fuel valve all the way to the right to put in ON position.



Vanguard Engine: Move throttle all the way left to put it in the ON position.

7. With one hand, squeeze the trigger of the spray gun, so the water is flowing. Brace the pressure washer with your foot. With the other hand, grip the recoil handle and slowly pull it out until you feel resistance. Pull briskly on the recoil. You may have to pull it several times before it starts running.
8. Once the engine has warmed up, disengage the choke by moving the choke lever all the way **RIGHT** on all models except the HONDA GC where the choke tab is pushed all the way **IN**. If it stalls, then it needs to get warmer before the choke is turned off. Restart the engine, let it warm up, and then try turning the choke off again.

Important Note: The pressure washer has been designed to run at full throttle. If you lower the throttle then the load-to-power ratio between the engine and pump will be incorrect. This will cause undue strain on the system while pressure washing, causing parts to wear quicker.

ELECTRIC START

For units that are equipped with an electric start engine.

1. Follow all the set ups already described up to the point of pulling the recoil.
2. Connect the battery cable (battery must be connected and charged to use electric start).
3. With one hand, squeeze the trigger of the spray gun so the water is flowing. With the other hand, turn the key on the engine to the 'ON' position to start the engine.
4. Once the engine starts, release the key.

• HONDA GX390



• HONDA GX690 IGX800



• POWEREASE



Engine	Min. Rec. Battery Specifications	Total Wire Length (Positive+Neutral)	Minimum AWG
GX390 / P.EASE	12V, 24Ah	<1.5m	10AWG (6mm ²)
GX690/IGX800	12V, 45Ah	<1.5m	6AWG (16mm ²)
		<2.3m	4AWG (25mm ²)

Note: positive terminals and connections must be insulated

In normal operation, to stop the engine:

1. Turn the fuel valve to the OFF position.
2. While holding the spray gun trigger, turn off the engine. Reference the below for the method to turn off the various pull-start engines. If it is an electric start model, turn the ignition key to the left.

Emergency Stop: Switch the engine to the OFF position immediately. This will stop the engine right away, but may trap pressure in the system, which may prevent restarts or the ability to remove the hose or spray gun.

1. Turn off the water source, and squeeze the trigger again to release pressure and water before disconnecting the hoses.
2. Drain the water out of the hoses before putting into storage.

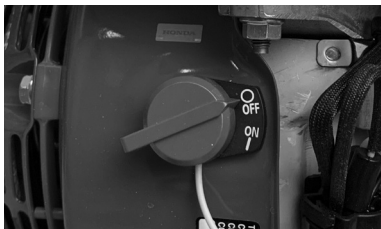

- HONDA GX
- POWEREASE
- KOHLER SH270



Honda GC engine is switched OFF when the throttle lever is fully lowered to the bottom.



Kohler CH440 is switched OFF when the fuel valve lever is moved all the way to the left.



Vanguard engine is turned off when throttle lever is moved all the way to the right.

ELECTRIC MOTOR START PROCEDURE

1. Review all the safety warnings at the beginning of the manual. Turn the motor to the off position.
2. Follow all the pre-operation steps before starting.
3. Connect pressure washer to a power source that matches the unit's requirements. It is critically important to have the pressure washer connected to the correct power source, including volt, amp, and circuit breaker capacity. Using a wrong power source will prevent start up, or damage the motor causing it to fail.
4. Hold the spray gun, point it in a safe direction and squeeze the trigger.
5. Locate the ON/OFF switch on the pressure washer. Brace yourself for possible kickback from the spray wand, and turn machine on.

If your electric pressure washer is equipped with an auto start/stop system, it will completely turn off when the spray gun trigger is released. Both pump and motor will be inactive even though it is plugged in and turned on. When the trigger is squeezed, the system will detect this and turn on. There will be a time delay between depressing/releasing the trigger and the machine turning on/off.

Always turn the machine off when it is not going to be used for a significant period of time. Do not rely on the auto start/stop system because if it fails, it will lead to pump and/or motor failures.

ELECTRIC MOTOR STOP PROCEDURE

1. Keep the spray gun trigger squeezed and pointing in a safe direction.
2. Turn the motor to the off position.
3. Keep trigger squeezed to make sure all the pressure is released and it is only garden hose pressure.
4. Unplug machine (if applicable, some may be hard wired).
5. Disconnect and drain hoses.

GENERAL PRESSURE WASHER OPERATION TECHNIQUES

1. Always follow safety practices as outlined.
2. Always begin spraying at a safe distance from the intended surface and move closer until the desired cleaning effect can be observed.
3. Generally, do not use a 90° spray angle. Instead, it is usually more effective to use a shallower angle so that the reflecting spray can be directed in safe and controlled direction.
4. Holding down the trigger, move the wand side-to-side to clean the surface. Once you get a feel for how the cleaning performance behaves you will naturally find your rhythm.
5. Always be aware of what you are spraying and take greater care on fragile surfaces such as wood or glass to prevent damage.
6. Always remember to squeeze the trigger once every 30 seconds to flush the pump with cool water to prevent overheating.
7. If you have to stop washing for more than a few minutes, you should turn off the machine.

HOW TO CONTROL PRESSURE

- The pressure washer is preset at the factory to deliver the optimum performance for its set up.
- Do not adjust the unloader.
- Adjusting the unloader can lead to failures, including poor performance, engine stalling, and breaking internal parts of the pump and unloader.
- The primary method of controlling pressure is by the distance between the nozzle and the surface. Always start far away and slowly move closer to the surface.
- The angle of spray to the surface will also influence pressure. For example, coming at the surface at a 90° angle will have more impact force than a shallow angle.
- Pressure can also be controlled by the type of nozzle that is put into the tip. The wider the spray, the less pressure directly impacting the surface.
- Pressure can also be decreased by using nozzles with a larger orifice size.
- Be careful when cleaning any soft surface like wood or anything that can crack or break apart, like glass or paint.

CLEANING WITH DETERGENTS

1. The black soaper nozzle must be installed on the spray gun wand. It is the only nozzle that will draw soap through the pressure washer system.
2. The detergent being used must have thin viscosity (similar to water).
- 3a. For models without an onboard soap tank; fill a container with detergent and place it next to the pressure washer. Connect the clear detergent suction tube to the brass barb on the pressure washer pump, and put the end with the filter into the detergent container.
- 3b. For models with an onboard soap tank; fill the soap tank with the detergent.
4. Turn on the pressure washer and spray the water. You will be able to see the detergent moving through the suction tube. Once the detergent is spraying out the nozzle, it will cause foam to appear.
5. When using detergent, spray the desired area and give it some time for the soap to chemically breakdown the dirt chemically. Then, wash it off with water before it dries. Do not let the detergent dry on the surface as it may result in damage.
6. When you are finished using the detergent you must flush the detergent injector system to prevent detergent residue from building up. To rinse, use clean water (either in a separate container or in the onboard soap tank). Spray for at least two minutes while drawing the clean water through the soap system.

STORAGE

Improper storage of the pressure washer will lead to failures that are not covered by warranty. In general, cover the pressure washer and store it in a clean and dry location. Wipe off any dirt or water.

⚠ WATER – FREEZING WARNING

Leaving water in the pump and accessories can result in damage if the water freezes. Water will expand when it turns to ice. The resulting force will cause ruptures and crack brass fittings, valves, and seals requiring complete replacements (not warrantable).

1. When the unit is not in use, drain all the hoses and spray gun assembly.
2. If the unit is going to be stored for an extended period, or if there is any chance the pressure washer will be exposed to freezing temperatures, then plumbing/RV anti-freeze must be cycled through the pumps water ways.
3. We recommend using BE Power Equipment Pump Saver Anti-Freeze. It has a specially designed cap to thread right onto the garden hose fitting of the pump. (Part number 85.490.046, contact your local dealer).
4. To apply, first ensure the engine and fuel valve are in the OFF position.
5. Thread the bottle onto the garden hose fitting of the pump and open the valve on the cap. Pull the recoil to cycle the anti-freeze solution through the pump. It is recommended to squeeze the bottle to force the anti-freeze into the pump if needed. Continue until it comes out of the high-pressure hose fitting. At this point, anti-freeze is protecting all the internal water chambers of the pump.
6. The best defense against freezing is to store the pressure washer in a warm location that will not be exposed to freezing temperatures.

⚠ GASOLINE ENGINE FUEL SYSTEM WARNING

Gasoline degrades overtime and will leave solid residues if it dries out in your fuel system. This will clog the fuel system and result in failure to start the machine (not warrantable).

1. Fuel degrades quicker the more it is exposed to air, and the greater the ethanol percentage blend.
2. Fuel stabilizer is strongly recommended to slow down the degradation process of fuel. Best practice is to mix the fuel stabilizer in the fuel storage container.
3. If the unit will not be used within 30 days, then drain all the fuel from the tank and carburetor.
 - 3.1 Use fuel stabilizer in the tank to mix with the fuel.
 - 3.2 To drain the fuel, have a container ready to catch the fuel.
 - 3.3 Use a wrench to loosen the bottom bolt of the carburetor and let all the fuel pour into the container. Once it stops, tighten the bolt. The fuel stabilizer that was put in the tank earlier will help prevent any residue fuel from drying into a hard residue.
 - 3.4 Open the fuel valve of the engine.
 - 3.5 To prevent wasting fuel, you can use the drained fuel in any vehicle that uses the same type of fuel.
 - 3.6 When storing gasoline, always use an airtight jerry can and fuel stabilizer for best results. Best practice is to store fuel for no more than a year before using it.

⚠ BATTERY (IF EQUIPPED)

1. Disconnect battery if it will not be used for two weeks or more.
2. Keep battery in a cool, dry place at normal room temperatures.
3. Is not used for 6 months or more, then it may need to be recharged.

GASOLINE ENGINE

Refer to the engine manual that came with your pressure washer for details.

Routinely check:

1. Oil level and condition
2. Air filter
3. Sparkplug
4. Watch for leaks

ENGINE MAINTENANCE SCHEDULE		
Engine Oil	Check	Every Use
	Replace	After the first 20 hours of operation. After every 100 hours there after. Inspection shows oil is dirty.
Air Filter	Check	Every Use
	Replace	When dirty or damaged.
Fuel Lines	Check	Every Use
	Replace	When damaged/leaking fuel.
Fuel Cap Filter	Check	Every Use.
	Replace	When unable to clean or if damaged.
Spark Arrestor (if applicable)	Check	Every 25 hours.
	Replace	When unable to clean or if damaged.
Spark Plug	Check	Every 100 hours.
	Replace	When unable to clean or adjust
Valve Clearance	Check	Every 300 hours.*
Idling RPM	Check	Every 300 hours.*
*Have serviced at an authorized service center.		

ELECTRIC MOTOR

No special maintenance needed. Keep clean.

PUMP MAINTENANCE

1. Applicable for pumps that have sight glasses and dipsticks where the oil can be inspected and changed.
2. Does not apply to sealed pumps which are maintenance free. These pumps are identified by having no way to check or change the oil. (No sight glasses or dipsticks).

PUMP MAINTENANCE SCHEDULE	
Oil Condition	Inspect before every use
First oil change	25 hours
Then Change after	Every 250 hours of use, 12 months. Inspection shows oil is dirty

If oil is milky in color, then water has leaked into the crankcase. Further inspections will be needed, including pump seals and ceramics plungers.

Fittings: Inspect for leaks and damage. Replace parts as needed.

WATER INLET FILTER

1. Inspect before every use
2. Rinse clean when dirty
3. Replace when damaged or leaking

BATTERY SCHEDULE (IF APPLICABLE)	
Charge Capacity	Check before every use
Recharge	Every 6 months or When no longer has enough charge to start.

GAS ENGINE TROUBLE SHOOTING		
PROBLEM	CAUSE	SOLUTION
Engine will turn over, but doesn't start (recoil can be pulled normally)	No Fuel.	Fill with fresh regular unleaded fuel
	Fuel is stale or contaminated.	Remove old fuel, replace with fresh fuel. May need to clean fuel system.
	Low Oil.	Fill with 10W30 motor Oil.
	Engine is switched off.	Turn switch to the ON position.
	Low RPM setting.	Turn throttle to full RPM (Rabbit).
	Choke not engaged.	Turn choke on.
	Fuel Valve is off.	Turn fuel valve on.
	Air filter too dirty.	Clean or replace.
	Fuel tank is overfilled and cannot breathe.	Drain some fuel to allow it to breathe.
	Oil in Carberator.	Remove the bolt from bottom of carburetor and flush with fuel.
Unable to pull Recoil (recoil feels seized)	Unloader set too tight.	Back off unloader.
	Gasoline in engine crankcase	Carburetor is plugged. Need to clean carburetor and engine.
	Trapped pressure in the pump.	Squeeze Trigger of the gun to release pressure.
	Oil In Air Filter.	Remove and replace air filter. Clean excess oil.
	Oil In spark plug cyclinder.	Remove and clean spark plug. Clear out oil from cycliner.
	Recoil mechanism failed	Replace recoil
	Internal engine failure	Replace engine
Engine runs then stops	No Fuel.	Fill with regulatar unleaded fuel.
	Low Oil.	Fill with 10W30 motor Oil.
	Unloader set too tight.	Back off unloader.
	Fuel Cap, or breather tube not breathing (where applicable).	Loosen fuel cap and if the machine runs, then clean or replace fuel cap/ valve.
	Fuel is stale or contaminated.	Remove old fuel, replace it with fresh fuel. May need to clean any fuel valves, carburator or filters.
	Leaking fuel.	Inspect for leaks and repair.

Rough running/odd sound	Choke is still engaged.	Turn choke off.
	Engine not at full throttle.	Turn engine to full throttle (rabbit).
	Air Filter Dirty.	Check air filter, replace if needed.
	Clogged Exhaust or Spark Arrestor.	Clean or replace as needed.
	Spark plug failure/dirty	Clean or replace spark plug
	Stale/bad fuel	Drain and replace with fresh fuel
	Valves needs adjustment	Take to service center for valve adjustment.

PUMP TROUBLE SHOOTING		
No water going through pump (with no hose/gun attached)	No water source attached.	Connect garden hose to pump.
	Water source is blocked.	Confirm water is flowing through hose without obstruction.
	Inlet filter plugged.	Clean or replace inlet filter.
Low water pressure	Low water inlet pressure.	Ensure inlet GPM/LPM flow is enough for pressure washer.
	Partially blocked water flow.	Ensure water flows through all hoses and fittings.
	Gun Nozzle issue.	Ensure nozzle is clean and right size.
	Gun Failure.	The gun is leaking or blocked, may need to replace.
	Water leaks in system.	Locate water leak, and fix or replace.
Water not getting through the spray gun	Unloader not properly adjusted.	Tighten unloader.
	Pressure hose not connected to pump.	Connect to pump.
	Hose obstruction.	Check for water through hose. Clean or replace.
	Gun failure.	May need to replace gun, especially if leaking.
Pressure Fluctuation	Spray nozzle plugged.	Clean or replace spray nozzle.
	Partially blocked inlet filter.	Remove garden hose, ensure filter is in place and clean.
	Inconsistent water source.	Ensure gallons per minute flow is enough for pressure washer.

Pressure Fluctuation	Clogged Check Valve.	Need to clean or replaces valves. Recommend call service center.
	Gun failure.	Trigger flaw, intermittedly siezed. May need to clean or replace.
	Worn valves and/or seals in head of pump.	Need to replaces seals. Recommend call service center.
Thermal Valve Leaking.	Unit was over heated.	Need to replace thermal valve.
Water in Oil. (pump oil is a milky color)	Unit overheated and thermal shocked.	Call service center, may need to replace pump.

ELECTRIC MOTOR TROUBLE SHOOTING		
Motor doesn't start. (makes no noise) (doesn't trip any breakers)	Unit is not switched on.	Turn switch to the ON postion.
	No power going to unit.	Check the cord for faults, make sure it is plugged into correct outlet.
	Breaker needs to be reset (wall and/or unit).	Reset Breakers.
	Faulty on/off switch.	Replace switch.
Motor overheats	Extension cord being used.	Plug directly into wall, or use much heavier gauge of cord.
	Unloader adjusted too tight.	Adjust or replace unloader.
	Clogged spray nozzle.	Clean or replace nozzle.
Motor doesn't start. (Trips wall breakers) (Trips reset on motor) (Motor only hums)	Too much pressure in the brass head.	Relieve pressure by pressing the trigger on the gun. Keep trigger held down while starting the machine.
	Extension cord being used.	Plug directly into wall, or use much heavier gauge of cord.
	Unloader adjusted too tight.	Back off unloader.
	Breaker rating doesn't match the pressure washer.	For example, if pressure washer is 17amp draw, it needs at least a 20amp breakers.
	Weak circuit breaker.	Try machine on several different outlets.
	Wall plug in too far from main electric panel.	Try machine on an outlet closer to the panel.
Motor doesn't start. (Trips wall breakers) (Trips reset on motor) (Motor only hums)	Nozzle size too small.	Try running machine without colored nozzle, if it works then get a larger nozzle.
	Power source not compatible.	Confirm voltage and amp requirements of the machine, make sure power source matches up.
	Extreme cold air temperature.	Operate in area where temperature is above 10°C.

GFCI TROUBLE SHOOTING		
Tripped GFCI. Will not reset.	GFCI tripped.	Unplug GFCI, reset, and then plug back in.
	GFCI has worn out and no longer functions.	Replace.
	Damaged cord, pinching or exposing wires.	Replace cord.
	Circuit breaker has tripped. Multiple items lose power.	Unplug unnecessary items then reset circuit breaker.
	Short in the system between outlet and breaker box.	Call an electrian to service the problem.

DETERGENT SYSTEM TROUBLE SHOOTING		
Not spraying detergent	Black spray nozzle not being use.	Only the black spray nozzle will work with the detergent system.
	Blak spray nozzle clogged or damaged.	Clean or replace as needed. Orifice must be unobstructed.
	Detergent pick-up tube is not in the solution.	Make sure the detergent container is full and the pick up tube is deeply submerged.
	Detergent pick-up tube is not attached to brass barb.	Make sure pick up tube is attached to the brass injector barb (not the black plastic barb).
	Detergent pick-up tube has been extrended.	If the pick-up tube is too long, it will no longer work. Use original length pick-up tube.
	Detergent too thick.	Thin solution. The viscosity needs to be similar to water.
	Ball-bearing in detergent injector is stuck.	Carefully remove brass injector. Clean ball bearing, spring, and brass making sure parts are moving freely.



WARRANTY

BE Power Equipment Inc. warrants to the original retail purchaser that our new products are free from defects in material and workmanship for the time-frames set forth. If a defect is found in a BE Power Equipment product within the limitations outlined in this warranty statement, BE Power Equipment, at its sole discretion, will repair, replace, or credit the product.

The warranty coverage begins on the date of the retail purchase by the end-user. Valid proof of purchase must be presented with the warranty claim.

This warranty is limited to defects that occurred during regular operational use. It does not cover failures due to lack of maintenance, negligence, abuse, misuse, including, but not limited to, freezing damage, alterations, chemical deterioration, scale buildup, rust, thermal shock, thermal expansion, transportation damage, oil changes, valve adjustments, fuel system maintenance, or the use of incorrect parts. Furthermore, using the wrong fuel, water, or power supply is considered a form of misuse.

This warranty does not cover normal wearing items such as O-rings, valves, seals, filters, spark plugs, or packings. These are normal wearing items and should be factored into your regular maintenance schedule.

The warranty herein is in lieu of all other warranties, express or implied, including any implied warranty of fitness for a particular purpose. BE Power Equipment does not authorize any of its dealers, service centers, agents, employees, or any other party to expand, extend, or modify the scope of this warranty in any manner on behalf of BE Power Equipment.

BE Power Equipment expressly disclaims liability for injuries to persons or property, or for incidental damages, rental loss, time loss, transportation costs, or consequential damages. It is the buyer's responsibility to ensure the correct installation, application, and use of the product purchased.

HONDA ENGINE WARRANTY

Honda requires their warranty claims to be evaluated and processed at their respective authorized service centers. Locations can be found on their respective website.

REGISTERED PRODUCT EXTENDED WARRANTY

BE offers an extended warranty on its products upon registration on the website. To qualify for the extended warranty, products must be registered within 90 days of purchase. This extended warranty does not apply to Honda engines; it is your responsibility to follow and adhere to the Honda warranty processes and procedures. BE retains sole discretion in determining whether the failure results from a manufacturing defect or workmanship and is the cause of premature failure.

PRODUCT REGISTRATION

Product registration form can be found at: bepowerequipment.com/product-registration



WARRANTY

WARRANTY PROCEDURE

Contact the BE Technical Service department at 1-866-850-6662 or EMAIL us (servicecenter@bepressure.com) with the following information

- Model/part number
- Serial number (if applicable)
- Copy of the original purchase receipt
- Detailed description of the failure
- Any additional relevant details or photos pertinent to the situation

AUTHORIZED "BE" SERVICE CENTERS

Authorized BE service centers can be found at: bepowerequipment.com/service-centers

WARRANTY TIMELINES

COMPREHENSIVE BUMPER TO BUMPER WARRANTY

ENGINES AND MOTORS	STANDARD WARRANTY	REGISTERED EXTENDED WARRANTY
HONDA GX	3 YRS Through Honda	N/A
VANGUARD	3 YRS	5 YRS
KOHLER	3 YRS	5 YRS
POWEREASE GAS ENGINES	3 YRS	5 YRS
POWEREASE ELECTRIC MOTORS	1 YR	5 YRS
BALDOR ELECTRIC MOTORS	3 YRS	5 YRS
TECHTOP ELECTRIC MOTORS	3 YRS	5 YRS

PRESSURE WASHERS	STANDARD WARRANTY	REGISTERED EXTENDED WARRANTY
WORKSHOP SERIES	1 YR	5 YRS
COMMERCIAL SERIES	3 YRS	5 YRS **Excluding Honda Engines
INDUSTRIAL SERIES	3 YRS	5 YRS **Excluding Honda Engines

ACCESSORIES	STANDARD WARRANTY	REGISTERED EXTENDED WARRANTY
ALL ACCESSORIES	1 YR	N/A

BE POWER[®] EQUIPMENT

DO NOT RETURN THIS PRODUCT TO THE RETAILER
CONTACT OUR CUSTOMER SERVICE if you need assistance
with the assembly, operation, or if you experience a problem with your
pressure washer, please call 1-866-850-6662
Monday - Friday. 8AM to 430PM PST.

NE RENVOYEZ PAS CE PRODUIT AU DÉTAILLANT, CONTACTEZ
NOTRE SERVICE À LA CLIENTÈLE si vous avez besoin d'aide pour
l'assemblage, le fonctionnement ou si vous rencontrez un problème avec
votre nettoyeur haute pression, veuillez appeler le 1-866-850-6662
Lundi à Vendredi. De 8h à 430h PST.

NO DEVUELVA ESTE PRODUCTO AL MINORISTA
COMUNÍQUESE CON NUESTRO SERVICIO DE ATENCIÓN AL
CLIENTE si necesita ayuda con el ensamblaje, el funcionamiento o si
tiene algún problema con su hidrolimpiadora, llame al 1-866-850-6662
Lunes a Viernes, de 8AM a 430PM PST.

BEPOWEREQUIPMENT

.COM

02-2026
85.609.006