

**HDF REPLACEMENT FRONT BUMPER
2024 CHEVY SILVERADO 25-3500**

PARTS LIST:

1	HD Front Bumper Assembly	4	12mm x 130mm Hex Bolts
1	Driver/left Mounting Bracket	28	12mm x 32mm OD x 3mm Flat Washers
1	Passenger/right Mounting Bracket	14	12mm Nylon Lock Nuts
2	Driver/left Support Brackets	10	12mm x 50mm Hex Bolts
2	Passenger/right Support Brackets	4	10mm x 35mm Double Bolt Plates
2	Shutter Relocation "L" Brackets	9	10mm x 40mm Hex Bolts
2	Plastic Plugs for License Plate	8	10mm Lock Washers
1	Engine Block Heater Bracket	8	10mm x 27mm OD x 3mm Flat Washers
2	3mm Horseshoe Tow Hook Shim	10	10mm x 34mm OD x 3mm Flat Washers
2	2mm Horseshoe Tow Hook Shim	9	10mm Nylon Lock Nuts
1	4mm Allen Wrench	10	6mm x 20mm Hex Bolts
		20	6mm x 18mm OD x 1.6mm Flat Washers
		10	6mm Nylon Lock Nuts

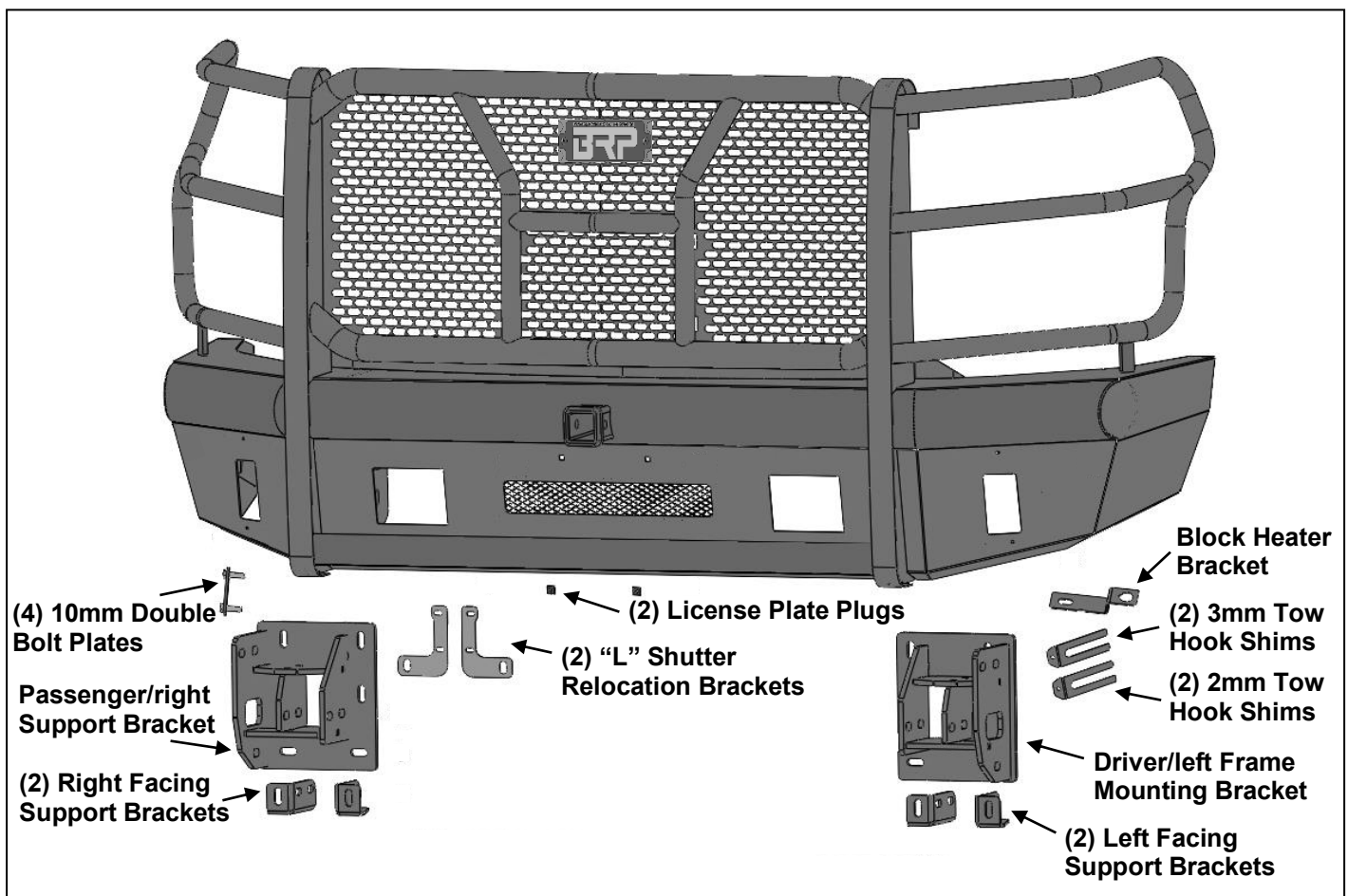

PROCEDURE:

REMOVE CONTENTS FROM BOX. VERIFY ALL PARTS ARE PRESENT. READ INSTRUCTIONS CAREFULLY BEFORE STARTING INSTALLATION. BUMPER IS HEAVY, ASSISTANCE IS HIGHLY RECOMMENDED TO AVOID POSSIBLE INJURY OR DAMAGE TO THE VEHICLE.

1. Start installation at the driver/left wheel opening. Remove the hardware attaching the fender liner to the front of the fender and the end of the plastic body panel, **(Figure 1)**. Carefully pull the fender flare out to release the clips attaching it to the body panel (fascia) and end of the fender, **(Figure 2)**. Only release the forward end of the flare, it is not necessary to remove the flare. Remove the screws attaching the end of the fascia panel to the front fender, **(Figure 3)**. Repeat this Step to release the passenger/right

HDF REPLACEMENT FRONT BUMPER 2024 CHEVY SILVERADO 25-3500

end of the fascia from the fender. Pull along the center of the fascia to release the remainder of the clips and move the plastic panel to a clean surface, **(Figure 4)**.

2. Open the hood and temporarily remove the hood release handle and plastic cover from the top of the grille and radiator **(Figure 5)**. Remove the hardware attaching the grille and pull it straight out from the vehicle. On models with grille mounted camera, unplug harness leading to the camera and remove the grille, **(Figures 6 & 7)**.
3. Remove the license plate and bracket if equipped. Unplug any wiring harnesses leading to the front bumper, **(Figure 8)**. Move all harnesses away from bumper.
4. Remove the hardware at each end of the bumper attaching the bumper supports to each side of the frame, **(Figure 9)**.
5. Place blocks or jack stands under the front bumper to support it during mounting bolt removal. Once the bumper has been safely supported, from above the bumper, remove the (2) factory upper and lower bumper bolts from each side, **(Figure 10)**. **WARNING!** Assistance is required to hold the bumper in place during bolt removal to prevent the bumper from falling. Remove the bumper assembly.
6. Remove the factory bumper brackets and tow hooks, (if equipped), from the end of frame, **(Figure 11 & 12)**. On models with lower radiator shutter assembly, unplug and remove the assembly, **(Figure 12)**.
7. Select the Driver/left Frame Mounting Bracket, **(Figure 14)**. Attach the Bracket to the mounting plate on the end of the frame with the included (4) 10mm x 40mm Hex Bolts, (4) 10mm Lock Washers and (4) 10mm x 34mm large Flat Washers, **(Figures 14 & 15)**. Do not tighten hardware at this time.
8. Next, select (1) 10mm Double Bolt Plate and (1) Left Facing Lower Support Bracket, **(Figure 16)**. Insert the Bolt Plate up into the open end of the frame and through the holes in the outside of the frame. Attach the Left Facing Support Bracket to the Double Bolt Plate with (2) 10mm Flat Washers and (2) 10mm Nylon Lock Nuts, **(Figure 16 & 18)**. Attach the front of the Support Bracket to the back of the Mounting Bracket with (1) 12mm x 50mm Hex Bolt, (2) 12mm Flat Washers and (1) 12mm Nylon Lock Nut, **(Figure 17)**. Do not tighten at this time. Repeat this Step to attach Right Facing Support Bracket to the inner side of the frame and back of the Mounting Bracket, **(Figures 16 & 17)**.
9. Repeat **Steps 7 & 8** to install the Passenger/right Frame and Support Brackets.
10. On models equipped with lower radiator shutter system, remove shutter assembly from outer plastic housing, **(Figure 19)**. Select (1) "L" Relocation Bracket. Use the previously installed (1) 12mm x 50mm Hex Bolt, (2) 12mm Flat Washers and (1) 12mm Nylon Lock Nut to attach the Bracket to the front of the Frame Bracket and Inner Support Bracket, **(Figure 20)**. Repeat this Step to attach the remaining "L" Bracket. Attach the shutter assembly to the "L" Brackets with the included (4) 6mm x 20mm Hex Bolts, (8) 6mm Flat Washers and (4) 6mm Nylon Lock Nuts. Do not overtighten the 6mm hardware or damage to the plastic shutter assembly may result.
11. **Models with fog lights:**
 - a. Remove the fog lights from the factory bumper, **(Figure 21)**.
 - b. Attach the driver/left fog light to the Bumper with the included (3) 6mm x 20mm Hex Bolts, (6) 6mm Flat Washers and (3) 6mm Nylon Lock Nuts, **(Figure 22)**. Do not overtighten hardware or damage to the light may result.
 - c. Repeat the previous Steps to attach the passenger/right side fog light.
12. With assistance, position the Bumper Assembly up to and over the Brackets. Temporarily support the weight of the Bumper. **WARNING:** To avoid possible injury or damage to the vehicle, do not proceed until the Bumper is fully and safely supported.
13. Line up the (3) holes in the driver/left side mounting plate on the inside of the Bumper with the (3) slots in the Frame Bracket. Attach the Bumper to the Bracket with the included (3) 12mm x 50mm Hex Bolts, (6) 12mm Flat Washers and (3) 12mm Nylon Lock Nuts, **(Figures 23 & 24)**. Do not fully tighten hardware at this time. Repeat this Step to attach the passenger/right side of the Bumper.
14. Level and adjust the bumper and fully tighten all hardware.
15. Select (1) OE tow hook if equipped. Flip the tow hook upside-down and insert it into the opening in the Bumper and into the Frame Bracket, **(Figure 25)**. Attach the tow hook to the Bracket with the included (2) 12mm x 130mm Hex Bolts, (4) 12mm Flat Washers and (2) 12mm Nylon Lock Nuts. **NOTE:** Use the thick 3mm Tow Hook Shims and thin 2mm Tow Hook Shims as necessary to tighten tolerance between the tow hooks and the Mounting Brackets. Fully tighten the tow hook hardware. Repeat this Step to install the passenger/right tow hook.

**HDF REPLACEMENT FRONT BUMPER
2024 CHEVY SILVERADO 25-3500**

16. Optional: Trim fender liners to match new bumper height, **(Figure 26)**.
17. Use the included (2) push-in Plastic License Plate Plugs to attach the front license plate, (if required), to the (2) holes in the front Bumper, **(Figure 27)**.
18. Models with grille mounted camera, remove screen from center window of Bumper, **(Figure 28)**.
19. Optional: Models with engine block heater; use universal Engine Block Heater Bracket to relocate the heater plug, **(Figure 29)**.
20. Do periodic inspections to the installation to make sure that all hardware is secure and tight.

To protect your investment, Do not use any type of polish or wax that may contain abrasives that could damage the finish. Mild soap may be used to clean the Front Bumper assembly.

Driver/left Side Installation Pictured



(Fig 1) Release hardware attaching fender liner from plastic panel (fascia-see arrows)

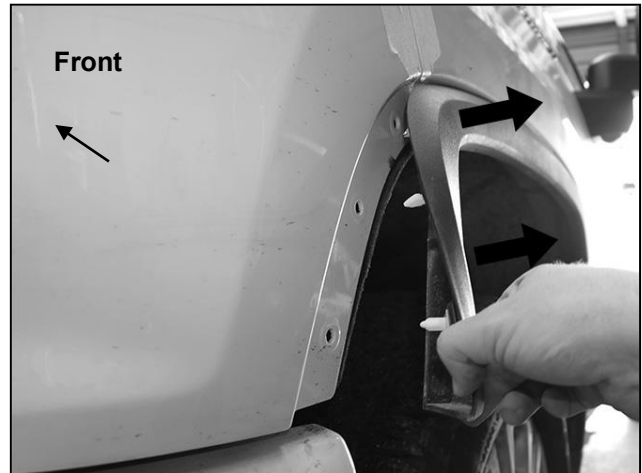

(Fig 2) Pull front end of fender flare out and away from fender. Do not remove flare, only release the front section

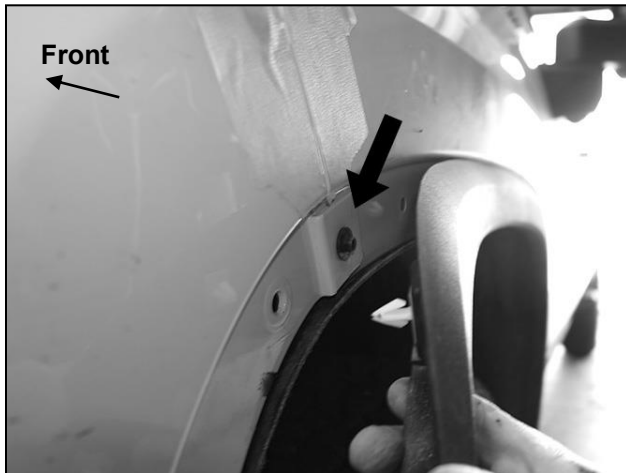

(Fig 3) Remove screws attaching plastic fascia panel to front end of fender (arrow)



(Fig 4) Remove plastic fascia from top of bumper

Driver/left Side Installation Pictured

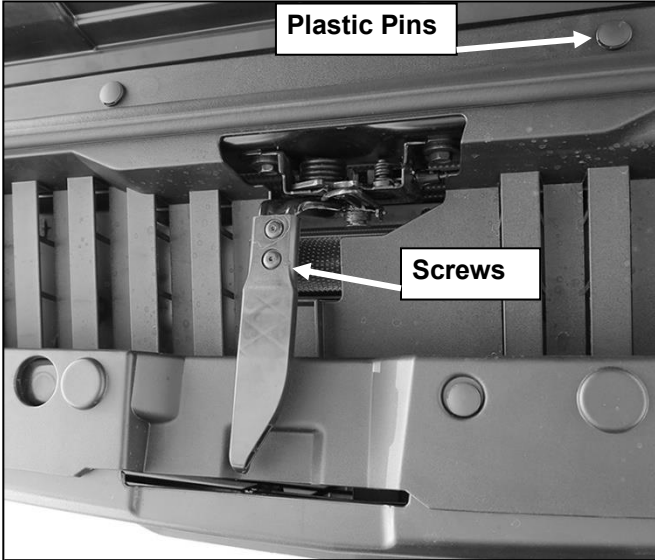

(Fig 5) Remove hood handle and radiator cover

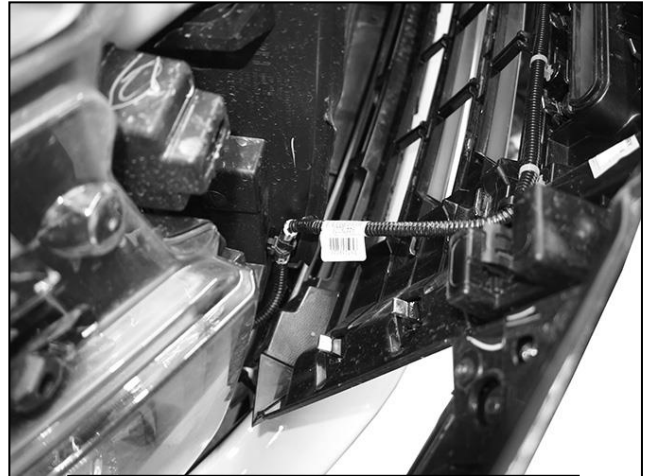

(Fig 6) Disconnect harness to camera (if equipped) and remove grille



(Fig 7) Grille and fascia removed

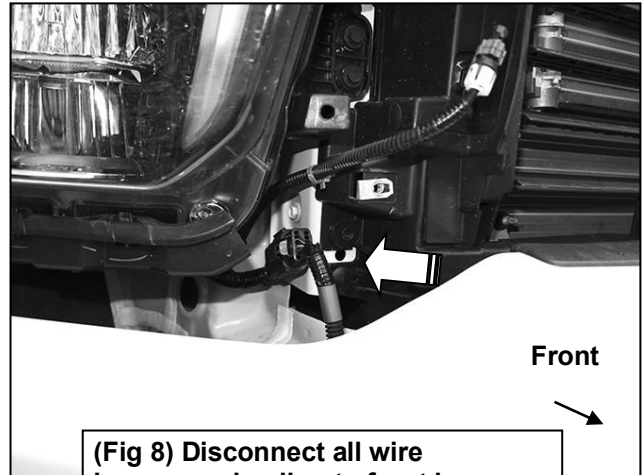

(Fig 8) Disconnect all wire harnesses leading to front bumper

WARNING! Do not crawl under bumper unless the bumper is properly supported on blocks or stands or the bumper may fall.

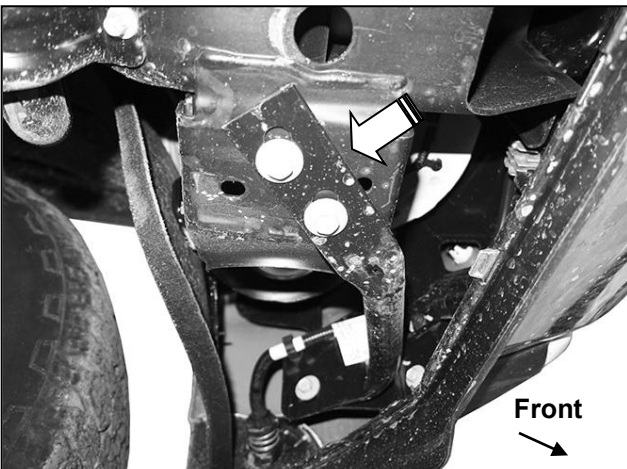

(Fig 9) Remove driver/left and passenger/right outer bumper supports attach to bottom of frame

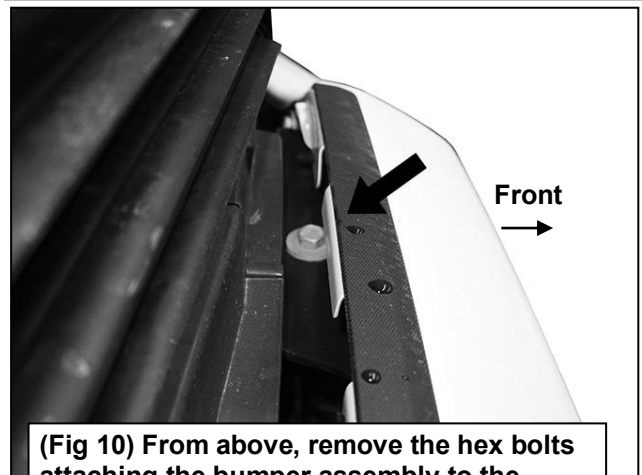

(Fig 10) From above, remove the hex bolts attaching the bumper assembly to the frame bumper brackets (top visible-arrow)

Driver/left Side Installation Pictured

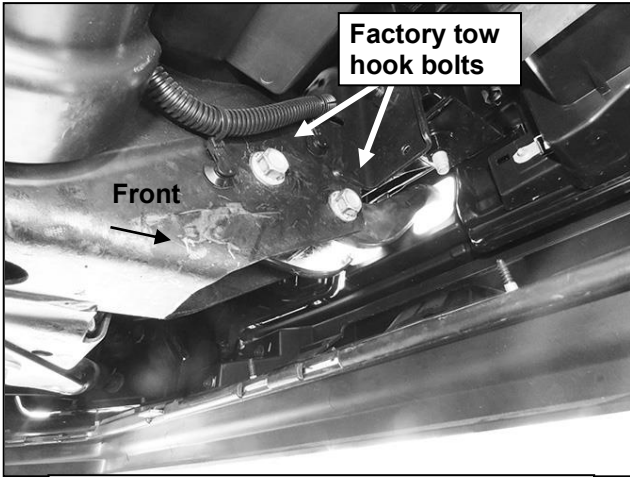

(Fig 11) Remove tow hooks, (if equipped) after bumper has been removed

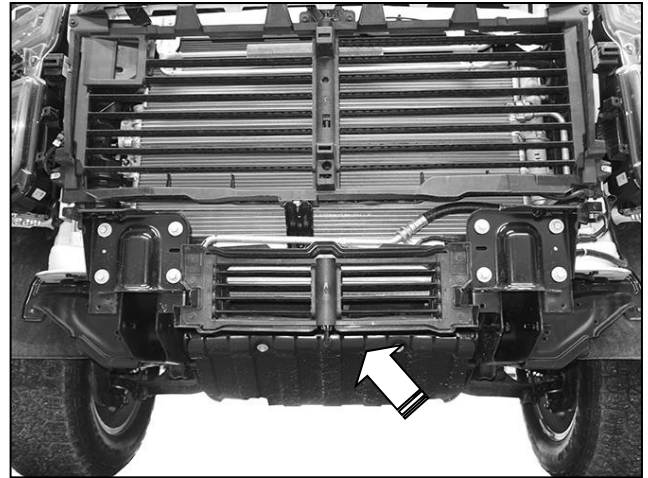

(Fig 12) Remove tow hooks, bumper brackets and shutter assembly (arrow) if equipped

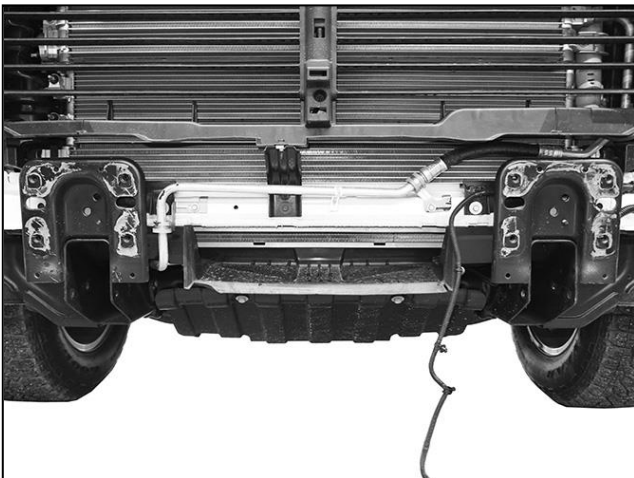

(Fig 13) Attach Frame Brackets to end of frame

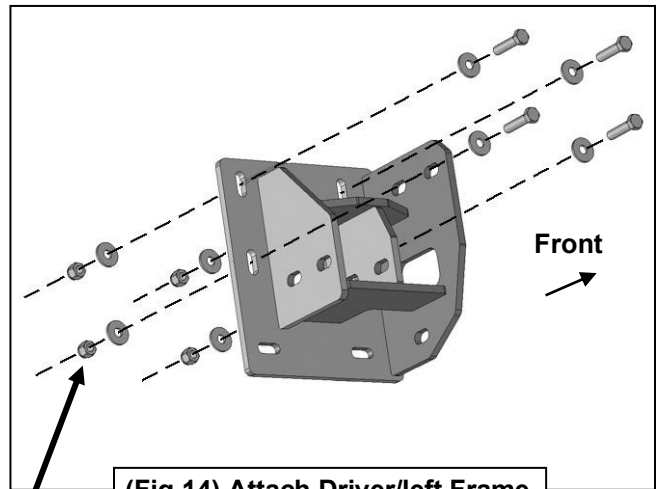

(Fig 14) Attach Driver/left Frame Bracket to end of frame

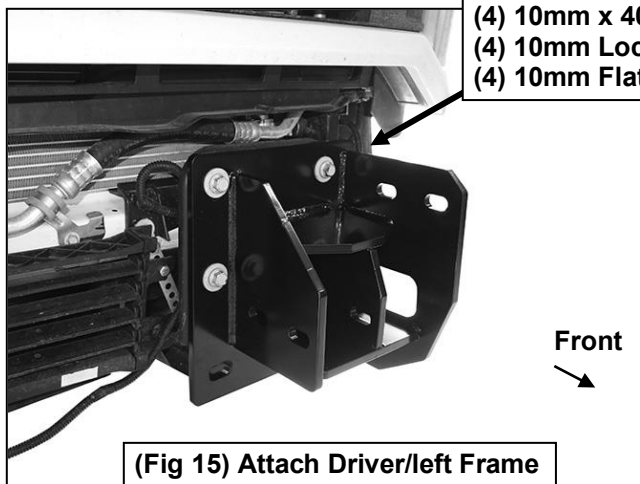

(Fig 15) Attach Driver/left Frame Bracket to end of frame

- (4) 10mm x 40mm Hex Bolts
- (4) 10mm Lock Washers
- (4) 10mm Flat Washers

Driver/left Side Installation Pictured

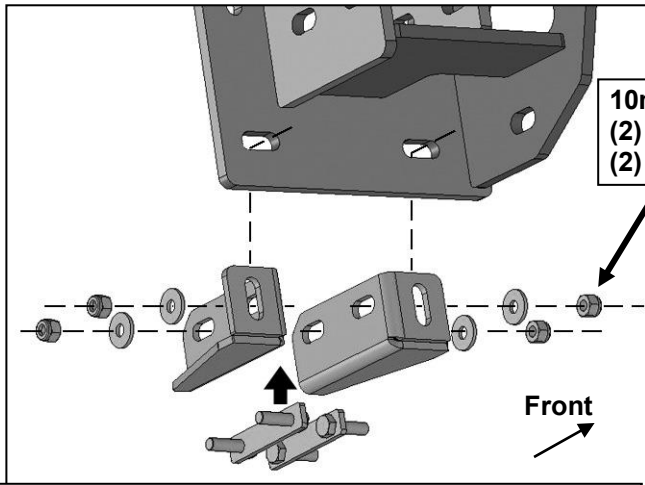

(Fig 16) Attach (1) Left Facing and (1) Right Facing Support Bracket to the sides of the frame

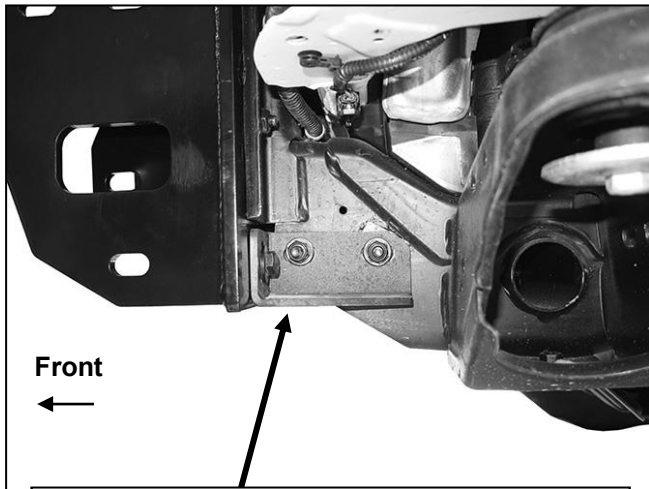

(Fig 18) Left facing Support Bracket installed

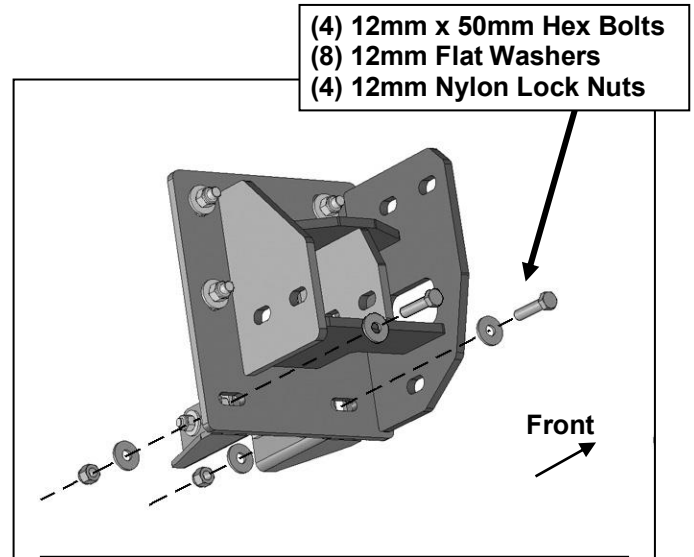

(Fig 17) Attach the Support Brackets to the bottom slots in the driver/left Frame Bracket



(Fig 19) Remove inner shutter assembly from plastic outer housing (if equipped)

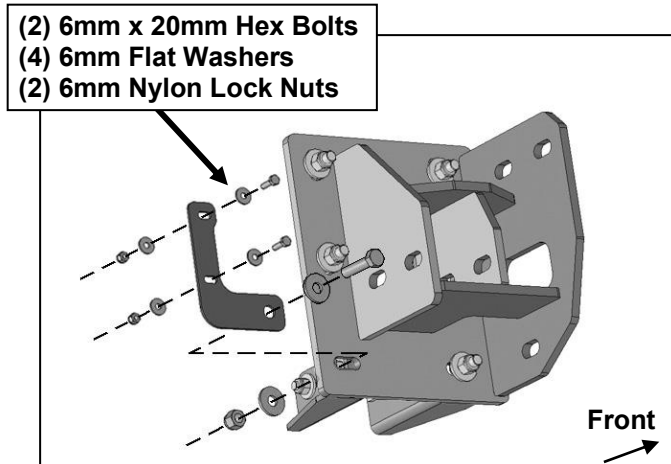

(Fig 20) Attach "L" Relocation Brackets to front of Frame Brackets. Attach shutter assembly, (if equipped), to front of Relocation Brackets

**HDF REPLACEMENT FRONT BUMPER
2024 CHEVY SILVERADO 25-3500**

Driver/left Side Installation Pictured

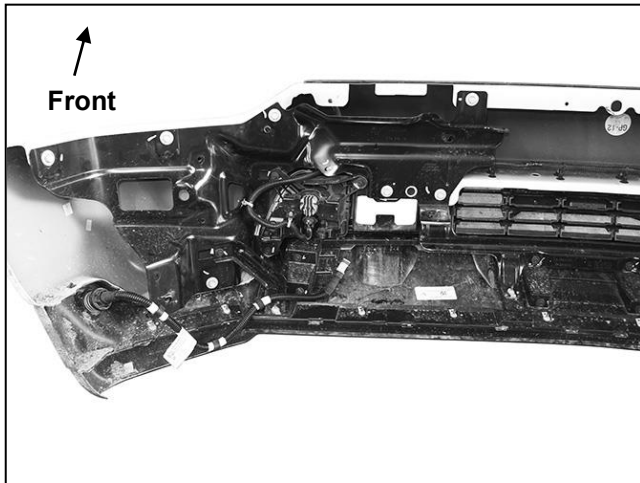

(Fig 21) Disassemble bumper and remove fog lights

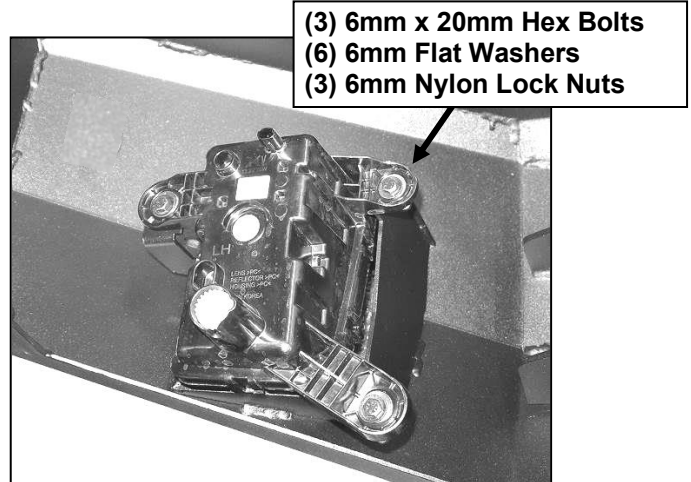

(Fig 22) Attach fog light to mounting tabs on driver/left side of Bumper

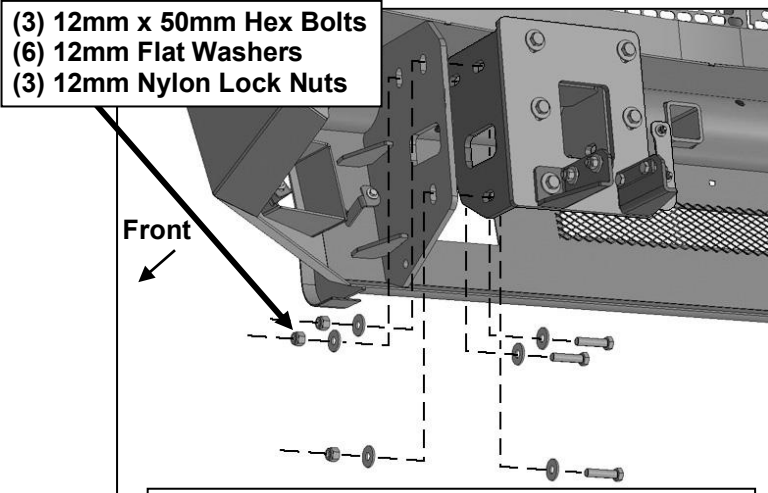

(Fig 23) Attach the Bumper to Frame Brackets

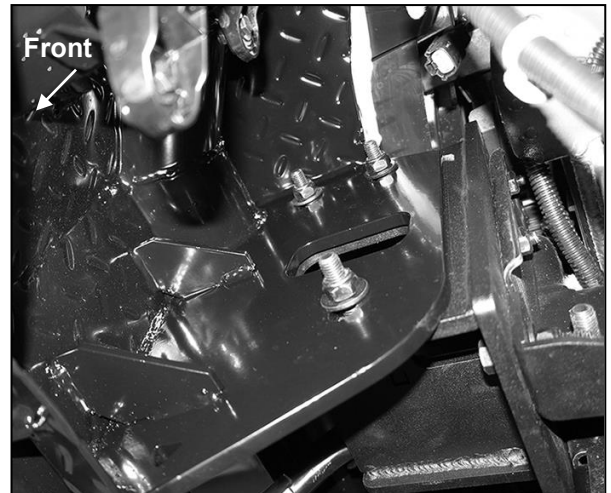

(Fig 24) Driver/left side of Bumper installed

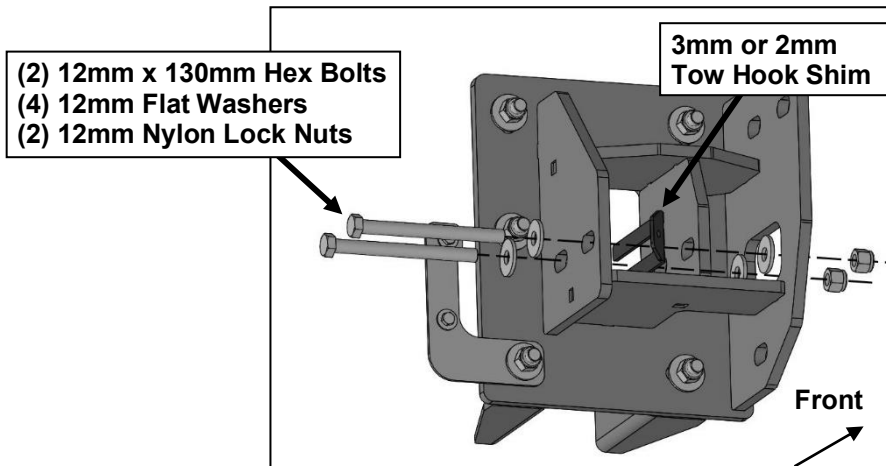

(Fig 25) Flip tow hook (if equipped), upside-down and attach to inside of Frame Bracket, NOTE: Use the 3mm or 2mm Tow Hook Shims to fill the gaps as needed.

**HDF REPLACEMENT FRONT BUMPER
2024 CHEVY SILVERADO 25-3500**



(Fig 26) Trim fender liner flush with bottom of bumper

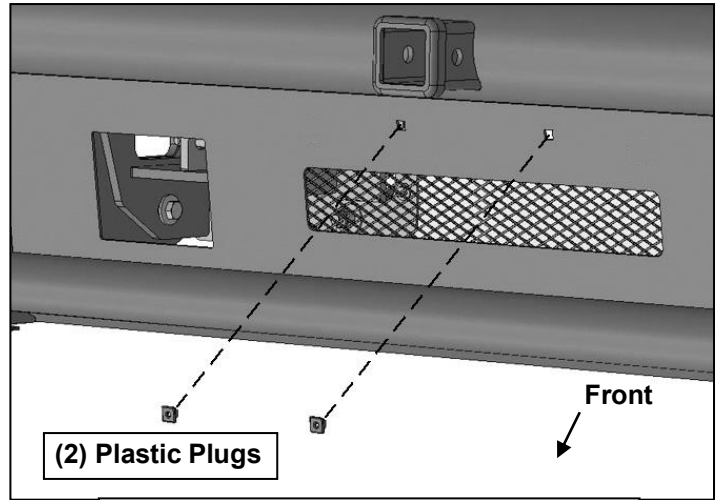

(2) Plastic Plugs

(Fig 27) Attach License Plate to Bumper

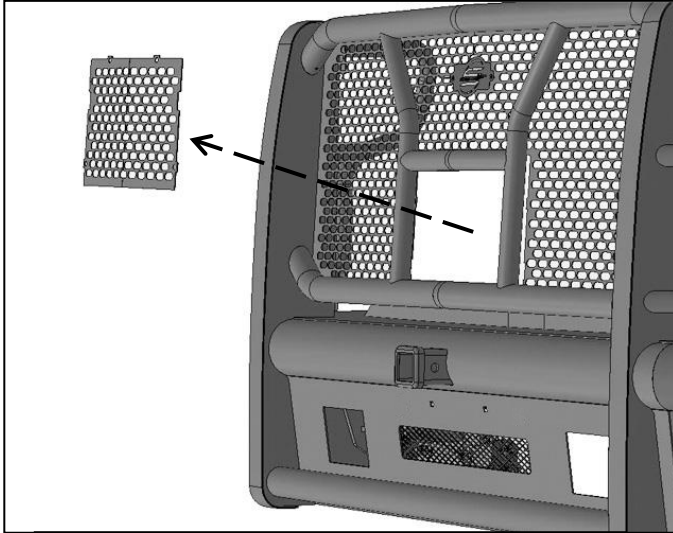

(Fig 28) Models with camera, remove screen

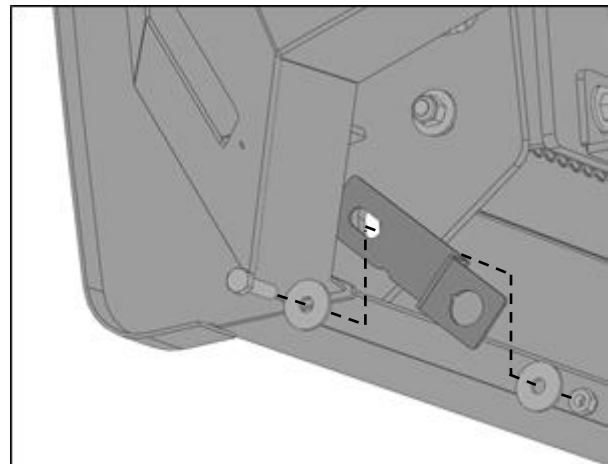

(Fig 29) Block heater relocation bracket example