

**ASSEMBLY INSTRUCTIONS  
INSTRUCTIONS DE MONTAGE  
INSTRUCCIONES DE MONTAJE**

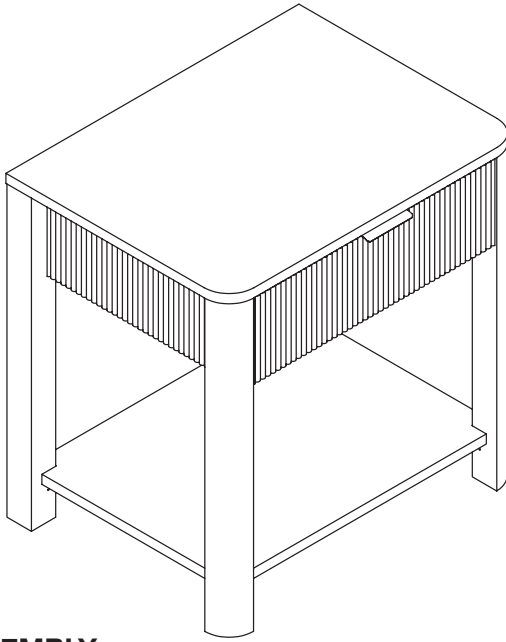

**NIGHTSTAND  
TABLE DE NUIT  
MESITA DE NOCHE**

**PRE-ASSEMBLY:**

*Two people are recommended to assemble this furniture.*

*Carefully remove all parts and hardware from carton, along with any protective packaging.*

*Locate and set aside the hardware kit before discarding packaging.*

*Do not discard any contents until after assembly is complete to avoid accidentally discarding small parts or hardware.*

*Assemble the furniture on a soft surface, and take extra care not to scratch or damage parts during the assembly.*

**PRÉASSEMBLAGE :**

*Deux personnes sont recommandées pour assembler ce meuble.*

*Retirez soigneusement de la boîte toutes les pièces, toute la quincaillerie, et tout emballage de protecteur.*

*Localisez et mettez de côté le jeu de quincaillerie avant de jeter l'emballage.*

*Ne mettez aucun élément de contenu au rebut avant de terminer l'assemblage au complet, afin d'éviter de jeter accidentellement de petites pièces ou un élément de quincaillerie.*

*Assemblez le meuble sur une surface douce et faites particulièrement attention à ne pas rayer ou endommager les pièces lors du montage.*

**ANTES DEL ENSAMBLADO:**

*Se recomiendan dos personas para montar este mueble.*

*Retire con cuidado todas las piezas y herramientas de la caja, junto con todo el envoltorio protector.*

*Localice y separe el equipo de accesorios antes de desechar el embalaje.*

*No deseche nada hasta después de haber terminado de ensamblar para evitar botar por accidente piezas pequeñas o herramientas.*

*Ensamble el mueble sobre una superficie blanda y tenga mucho cuidado de no rayar ni dañar las piezas durante el montaje.*

---

**Save these instructions**  
Made in Vietnam

**Conservez ces instructions**  
Fabriqué au Vietnam

**Guarde estas instrucciones**  
Hecho en Vietnam



## PRECAUTIONS — READ ALL BEFORE BEGINNING ASSEMBLY

*Do not place items on the shelves which exceed the maximum weight limits of:*

**Top Shelf: 50 lbs. (22.7 kg)**

**Drawer: 10 lbs. (4.5 kg)**

Usage with loads heavier than the maximum weights specified may result in instability, causing tip-over and resulting in death or serious injury.

When in use, this furniture must be placed on a flat, solid and level surface.

**DO NOT CLIMB ON, STEP ON, OR SIT ON THE SHELF OR THE DRAWERS OR THE TABLE TOP.**

To prevent objects from tipping and falling, remove all items from cabinet before adjusting the leveling feet or moving the furniture.

Do not use a drill or power tools to assemble this furniture, as it may weaken or damage parts.

When moving furniture or adjusting the leveling feet, never lift the cabinet by the top shelf. Always lift the cabinet at the base.

---

## PRÉCAUTIONS — LIRE TOUT AVANT DE COMMENCER L'ASSEMBLAGE

*Ne pas poser sur le meuble des objets dépassant la limite de poids de :*

**Étagère supérieure : 22,7 kg**

**Le tiroir : 4,5 kg**

L'utilisation avec des charges dont le poids dépasse les valeurs spécifiées peut entraîner l'instabilité, et le basculement pouvant provoquer la mort ou des blessures graves.

Durant l'utilisation, le meuble doit être posé sur une surface plate, solide et horizontale.

**NE PAS MONTER, MARCHER ET S'ASSEOIR SUR L'ÉTAGÈRE, LES TIROIRS OU LE PLATEAU DE LA TABLE.**

Pour éviter que des objets ne basculent et ne tombent, retirez tous les éléments de l'armoire avant de régler les pieds de nivellement ou de déplacer les meubles.

N'utilisez pas de perceuse ou d'outils électriques pour assembler ce meuble, car cela pourrait affaiblir ou endommager des pièces.

Lorsque vous déplacez des meubles ou réglez les pieds de nivellement, ne soulevez jamais l'armoire par l'étagère supérieure. Soulevez toujours l'armoire à la base.

---

## PRECAUCIONES — LEA TODO ANTES DE COMENZAR EL MONTAJE

*No coloque sobre los estantes artículos que excedan los límites máximos de peso:*

**Estante superior: 22.7 kg (50 lbs.)**

**El cajón: 4.5 kg (10 lbs.)**

Colocar cargas mayores que los pesos máximos especificados puede generar inestabilidad y, en consecuencia, desplomes que pueden causar la muerte o lesiones graves.

Cuando esté en uso, estos muebles deben colocarse sobre una superficie plana, sólida y nivelada.

**NO SE SUBA, PISE NI SE SENTE EN EL ESTANTE, LOS CAJONES O LA SUPERFICIE DE LA MESA.**

Para evitar que los objetos se vuelquen y se caigan, retire todos los artículos del gabinete antes de ajustar las patas niveladoras o mover los muebles.

No utilice un taladro o herramientas eléctricas para ensamblar este mueble, ya que puede debilitar o dañar las piezas.

Cuando mueva muebles o ajuste las patas niveladoras, nunca levante el gabinete por el estante superior. Levante siempre el armario por la base.

## PARTS / PIÈCES / PIEZAS

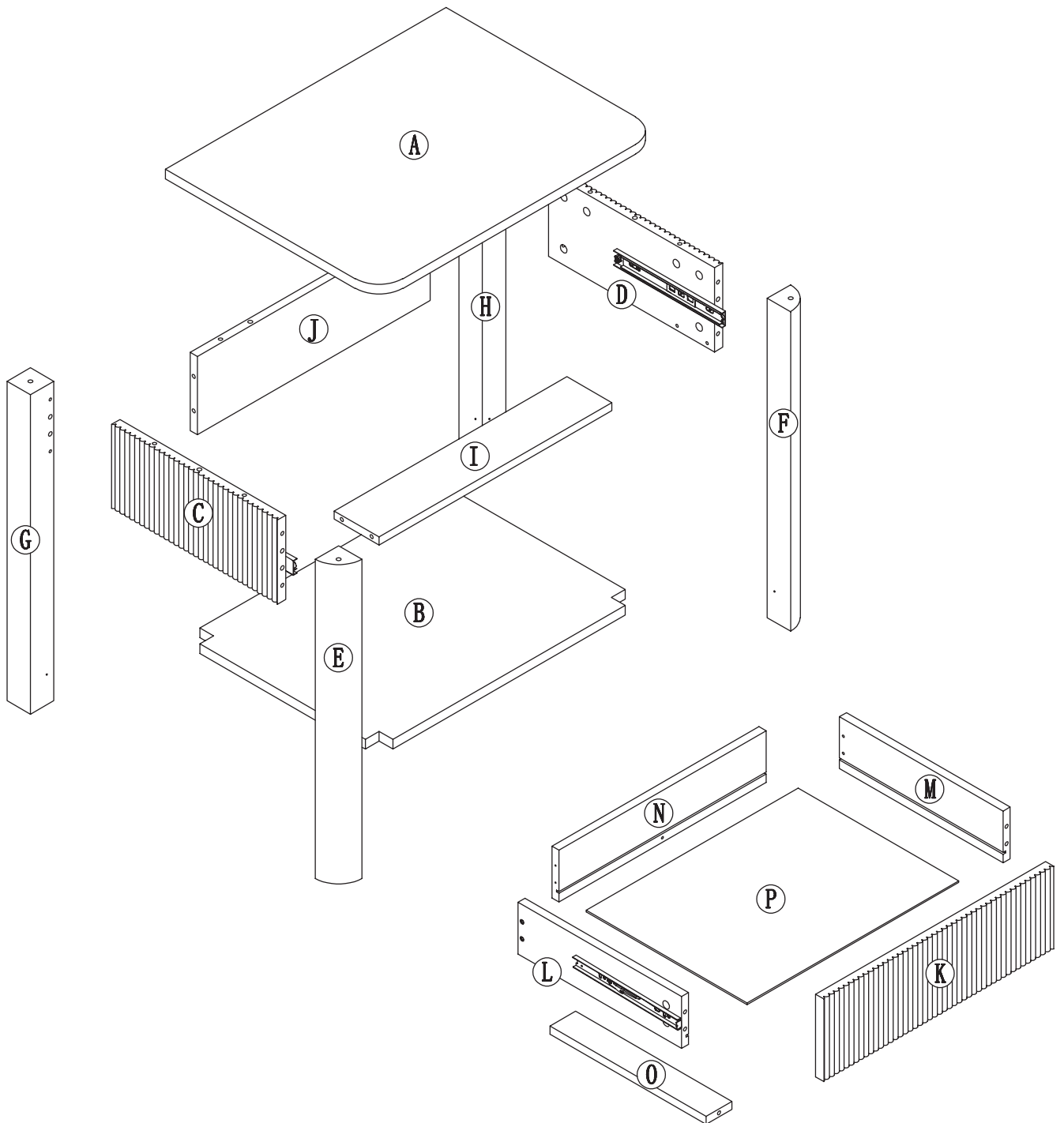

**NOTE:** This illustration is for parts identification/orientation purposes only. For assembly, see following pages.

**REMARQUE :** Cette illustration est uniquement à des fins d'identification / d'orientation des pièces. Pour le montage, voir pages suivantes.

**NOTA:** Esta ilustración es solo para fines de identificación / orientación de piezas. Para el montaje, consulte las páginas siguientes.

**PARTS / PIÈCES / PIEZAS**

Part Pièce Pieza	Description Description Descripción	Quantity Quantité Cantidad
------------------------	---	----------------------------------

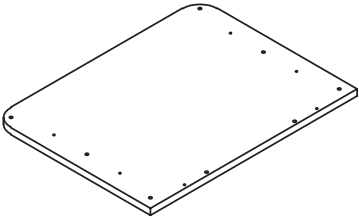
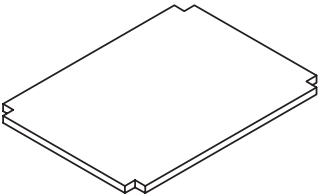
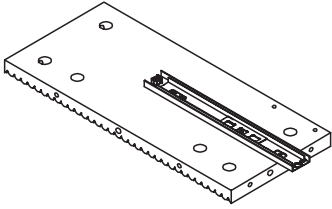
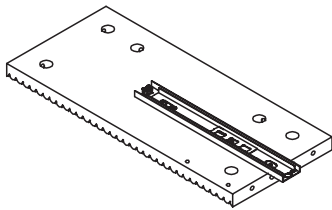
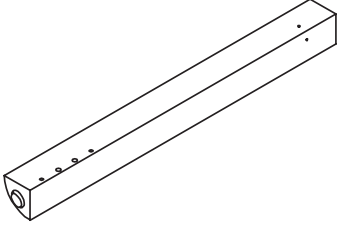
<b>A</b>		<b>1</b>
<b>B</b>		<b>1</b>
<b>C</b>		<b>1</b>
<b>D</b>		<b>1</b>
<b>E</b>		<b>1</b>

Part Pièce Pieza	Description Description Descripción	Quantity Quantité Cantidad
------------------------	---	----------------------------------

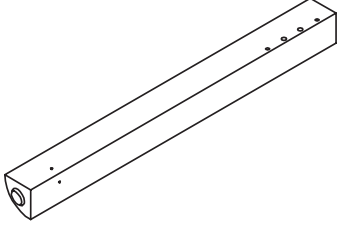
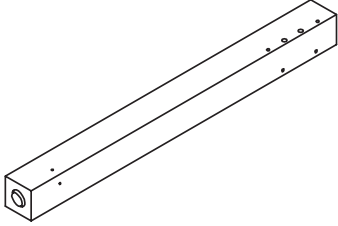
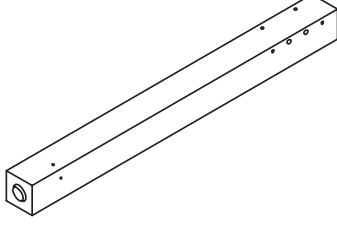
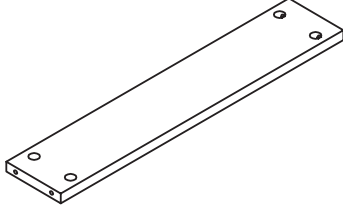
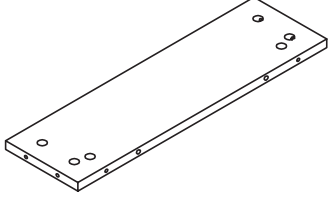
<b>F</b>		<b>1</b>
<b>G</b>		<b>1</b>
<b>H</b>		<b>1</b>
<b>I</b>		<b>1</b>
<b>J</b>		<b>1</b>

**PARTS / PIÈCES / PIEZAS**

Part Pièce Pieza	Description Description Descripción	Quantity Quantité Cantidad
------------------------	---	----------------------------------

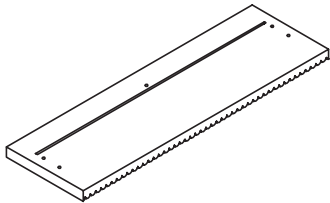
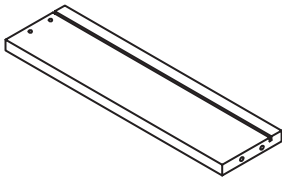
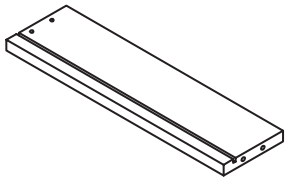

Part Pièce Pieza	Description Description Descripción	Quantity Quantité Cantidad
------------------------	---	----------------------------------

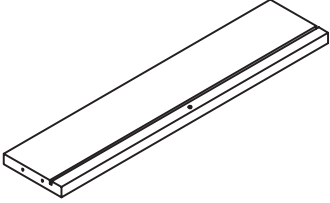
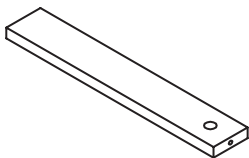
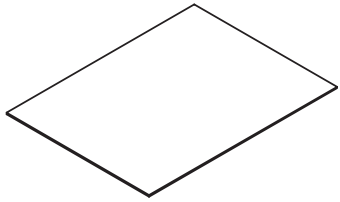
<b>K</b>		<b>1</b>
<b>L</b>		<b>1</b>
<b>M</b>		<b>1</b>

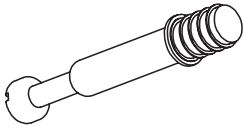

<b>N</b>		<b>1</b>
<b>O</b>		<b>1</b>
<b>P</b>		<b>1</b>

## HARDWARE / QUINCAILLERIE / FERRETERÍA

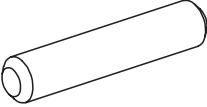
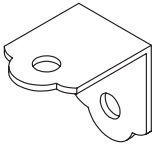
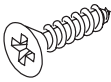
Part Pièce Pieza	Description Description Descripción	Quantity Quantité Cantidad
------------------------	---	----------------------------------

<b>1</b>	 <b>6 x 40 mm</b>	<b>27</b>
<b>2</b>	 <b>15 x 10 mm</b>	<b>27</b>
<b>3</b>	 <b>8 x 40 mm</b>	<b>16</b>
<b>4</b>	 	<b>8</b>
<b>5</b>	 <b>3.5 x 12 mm</b>	<b>2</b>

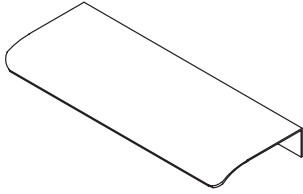
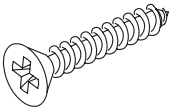
Part Pièce Pieza	Description Description Descripción	Quantity Quantité Cantidad
------------------------	---	----------------------------------

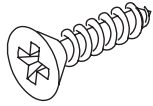
<b>6</b>	 	<b>1</b>
<b>7</b>	 <b>4 x 35 mm</b>	<b>5</b>
<b>8</b>	 	<b>5</b>
<b>9</b>	 <b>4 x 16 mm</b>	<b>16</b>

# INSTALLING THE CAM LOCKS

COMMENT INSTALLER LES SERRURES À CAME

CÓMO INSTALAR LAS CERRADURAS DE LEVA

1



*Do not overtighten!  
Ne pas trop serrer!  
¡No apriete demasiado!*

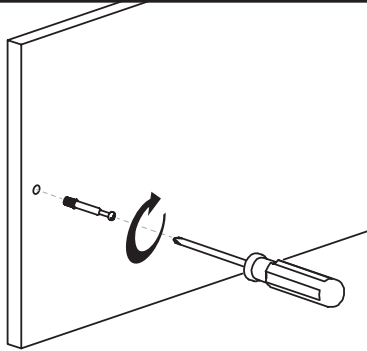

Screw the Cam Screw into the prethreaded hole. Tighten with a screwdriver until snug.

Vissez la vis à came dans le trou pré-fileté. Serrez fermement avec un tournevis.

Atonille el tornillo de leva en el orificio roscado previamente. Apriete firmemente con un destornillador.

2

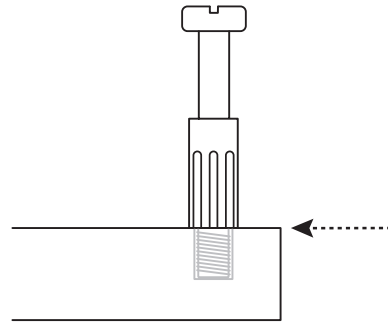

The base of the Cam Screw should be flush with the panel.

La base de la vis à came doit affleurer le panneau.

La base del tornillo de leva debe estar al ras con el panel.

3

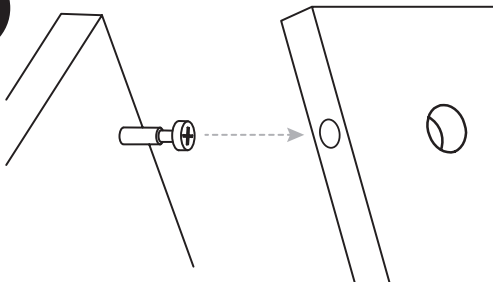

Connect the panels. Insert the Cam Screw into the small hole in the adjoining panel.

Connectez les panneaux. Insérez la vis de came dans le petit trou dans le panneau adjacent.

Conecte los paneles. Inserte el tornillo de leva en el pequeño orificio del panel contiguo.

4

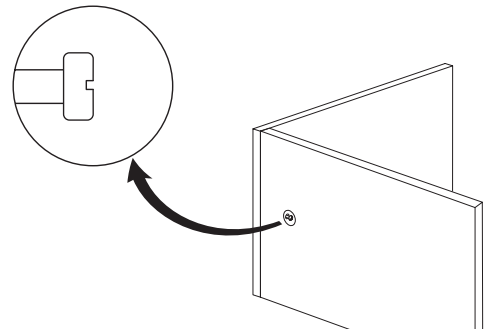

The head of the Cam Screw should be visible through the large hole.

La tête de la vis de came doit être visible à travers le grand trou.

La cabeza del tornillo de leva debe ser visible a través del orificio grande.

5

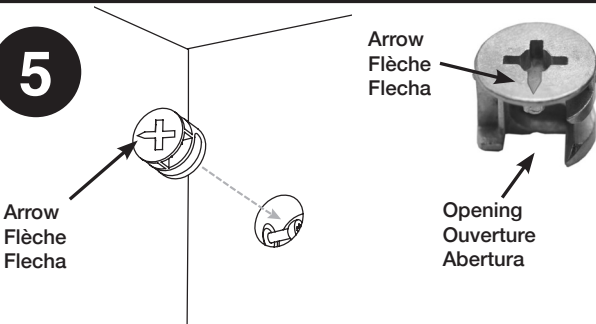

Insert the Cam Lock into the large hole. Make sure the arrow and the opening in the Cam Lock are facing the Cam Screw.

Insérez le verrou à came dans le grand trou. Assurez-vous que la flèche et l'ouverture dans le verrou à came font face à la vis à came.

Inserte el Cam Lock en el orificio grande. Asegúrese de que la flecha y la abertura en la cerradura de leva miren hacia el tornillo de leva.

6



*Do not overtighten!  
Ne pas trop serrer!  
¡No apriete demasiado!*

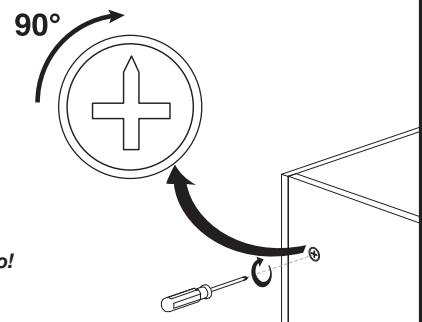

Using a screwdriver, turn the Cam Lock at least 90° clockwise to lock the two panels firmly together.

À l'aide d'un tournevis, tournez le serrure à came d'au moins 90° dans le sens des aiguilles d'une montre pour verrouiller les deux panneaux ensemble.

Con un destornillador, gire la cerradura de leva al menos 90° en el sentido de las agujas del reloj para cerrar los dos paneles juntos.



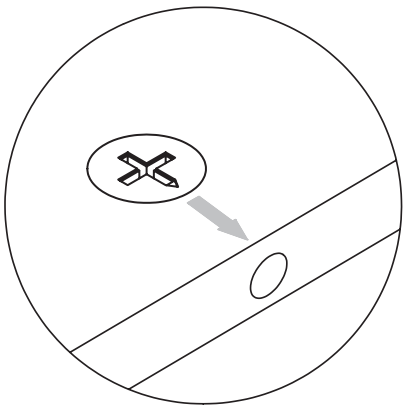
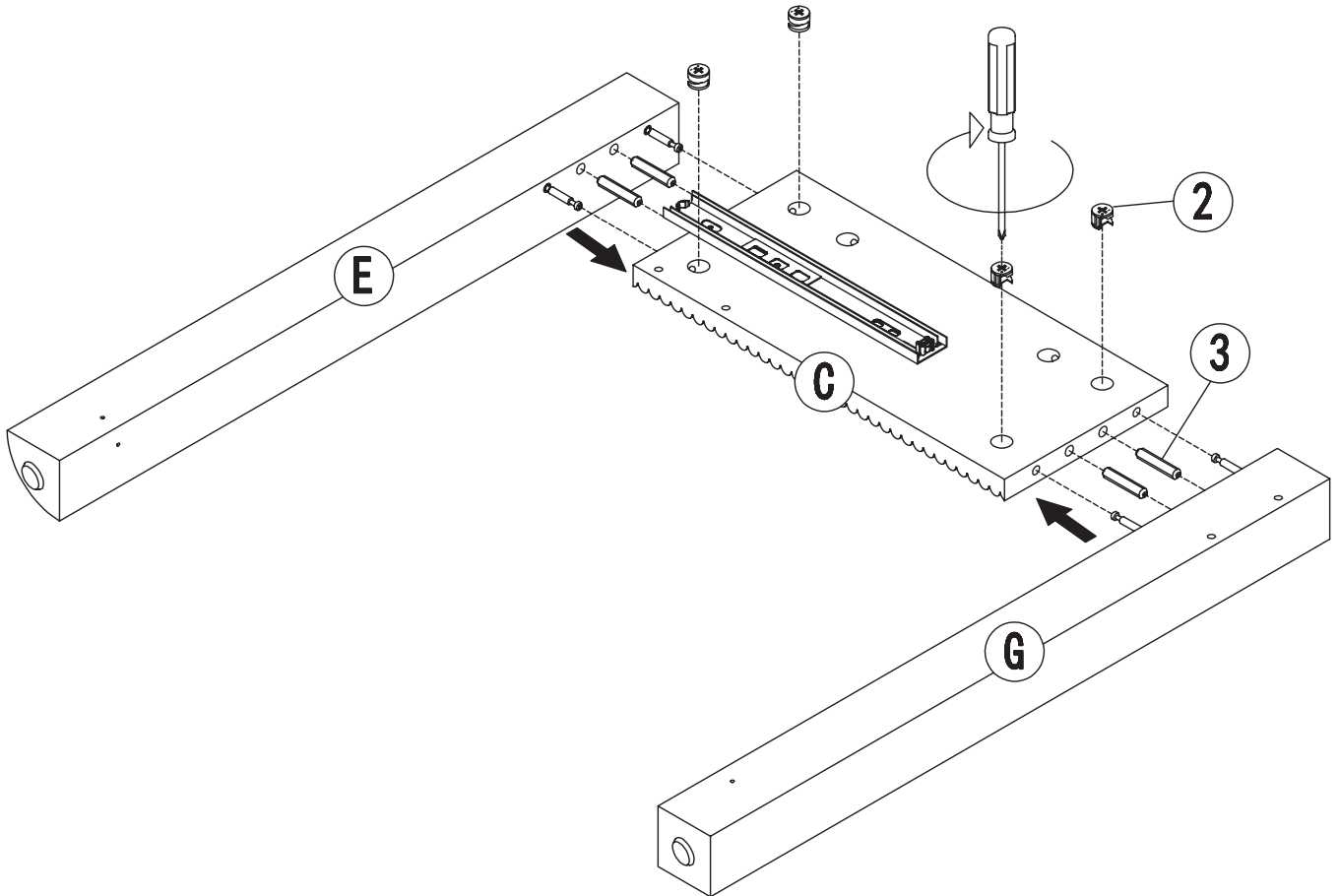
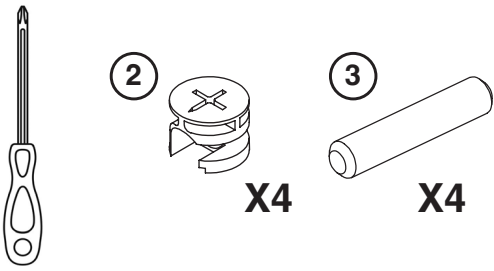

**NOTE:** THE ARROW IN THE CAM LOCK MUST POINT TOWARD THE HOLE.

**REMARQUE :** LA FLÈCHE DANS LE VERROU À CAME DOIT POINTER VERS LE TROU.

**NOTA:** LA FLECHA EN LA CERRADURA DE LEVA DEBE APUNTAR HACIA EL ORIFICIO.

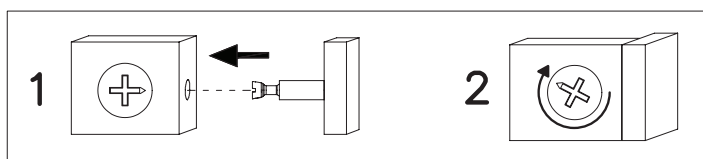

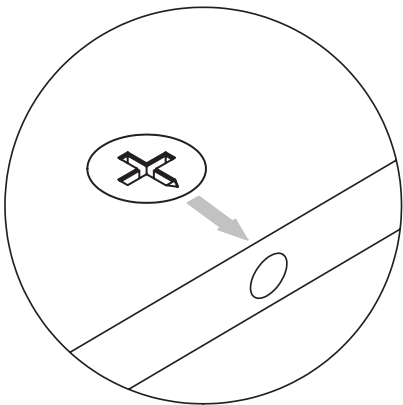
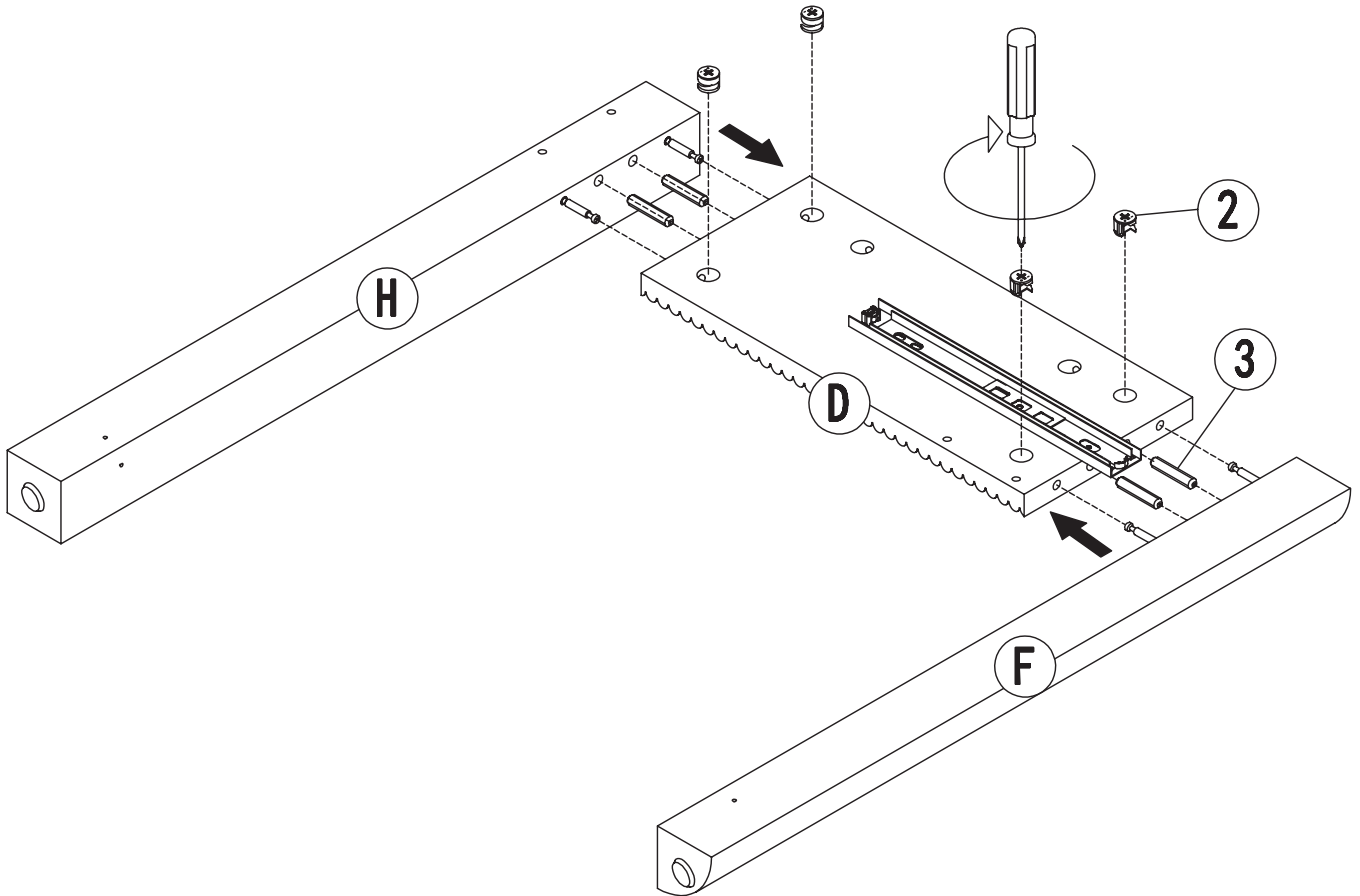
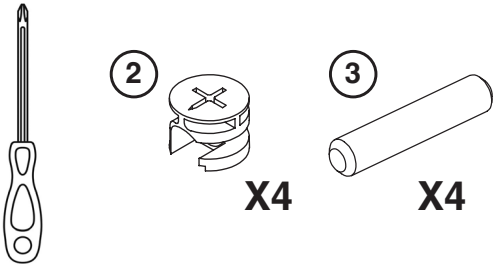

**NOTE:** THE ARROW IN THE CAM LOCK MUST POINT TOWARD THE HOLE.

**REMARQUE :** LA FLÈCHE DANS LE VERROU À CAME DOIT POINTER VERS LE TROU.

**NOTA:** LA FLECHA EN LA CERRADURA DE LEVA DEBE APUNTAR HACIA EL ORIFICIO.

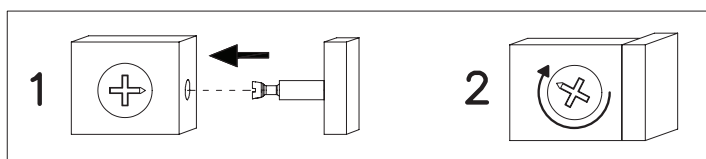

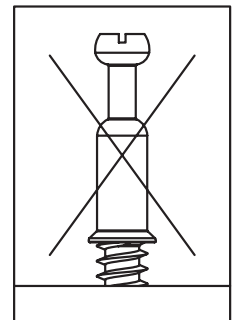
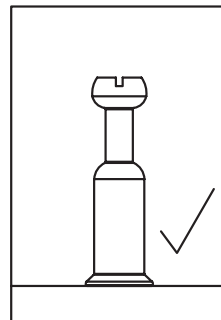
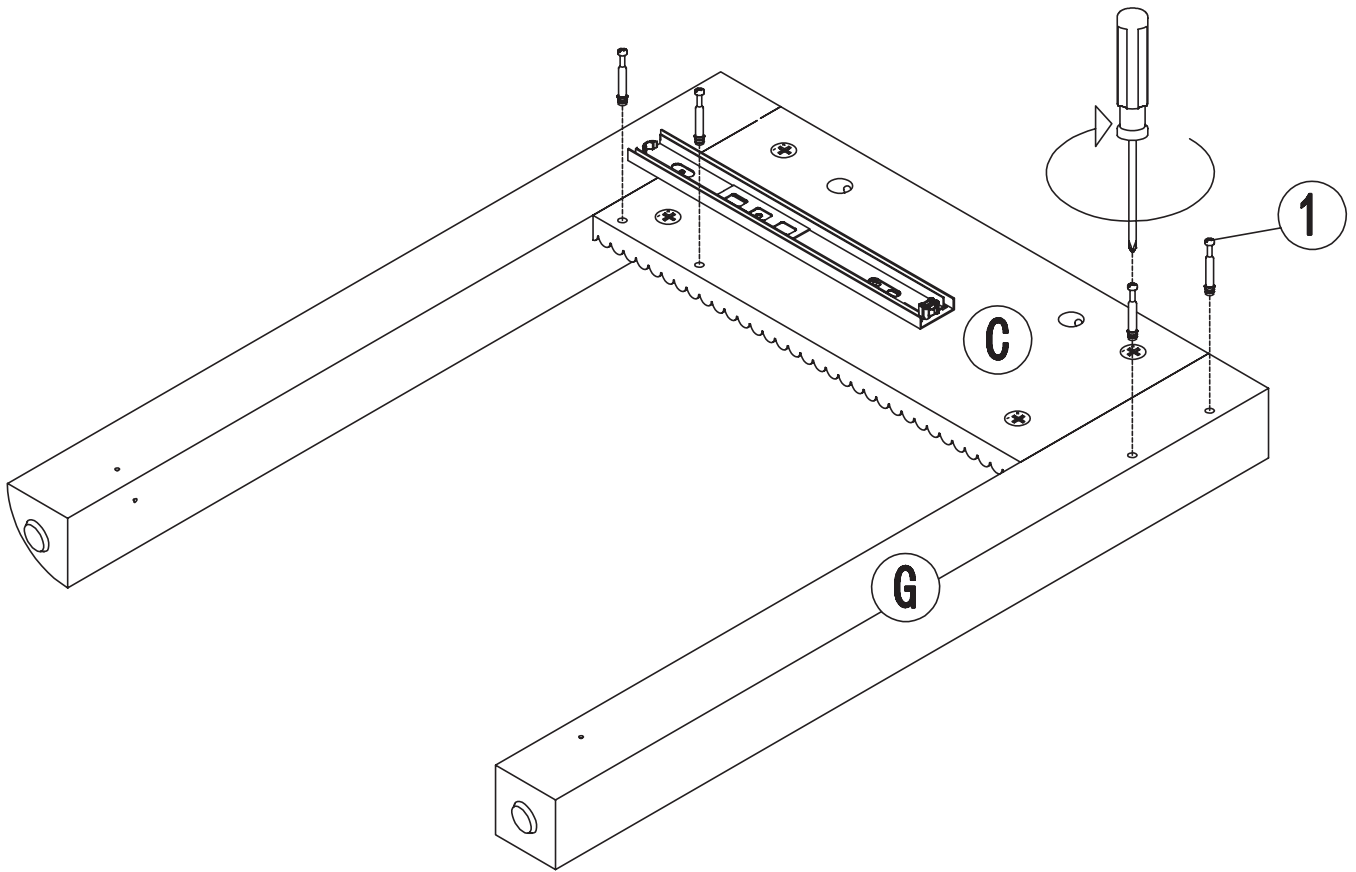
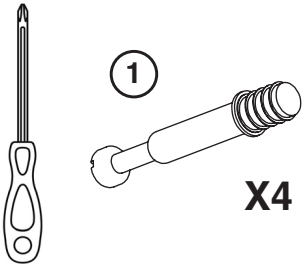

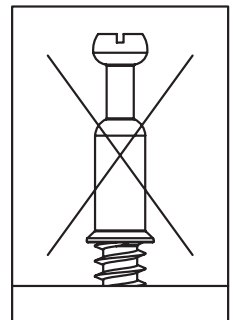
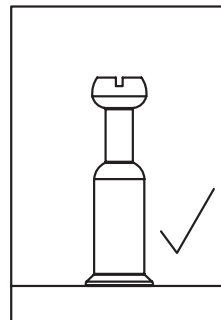
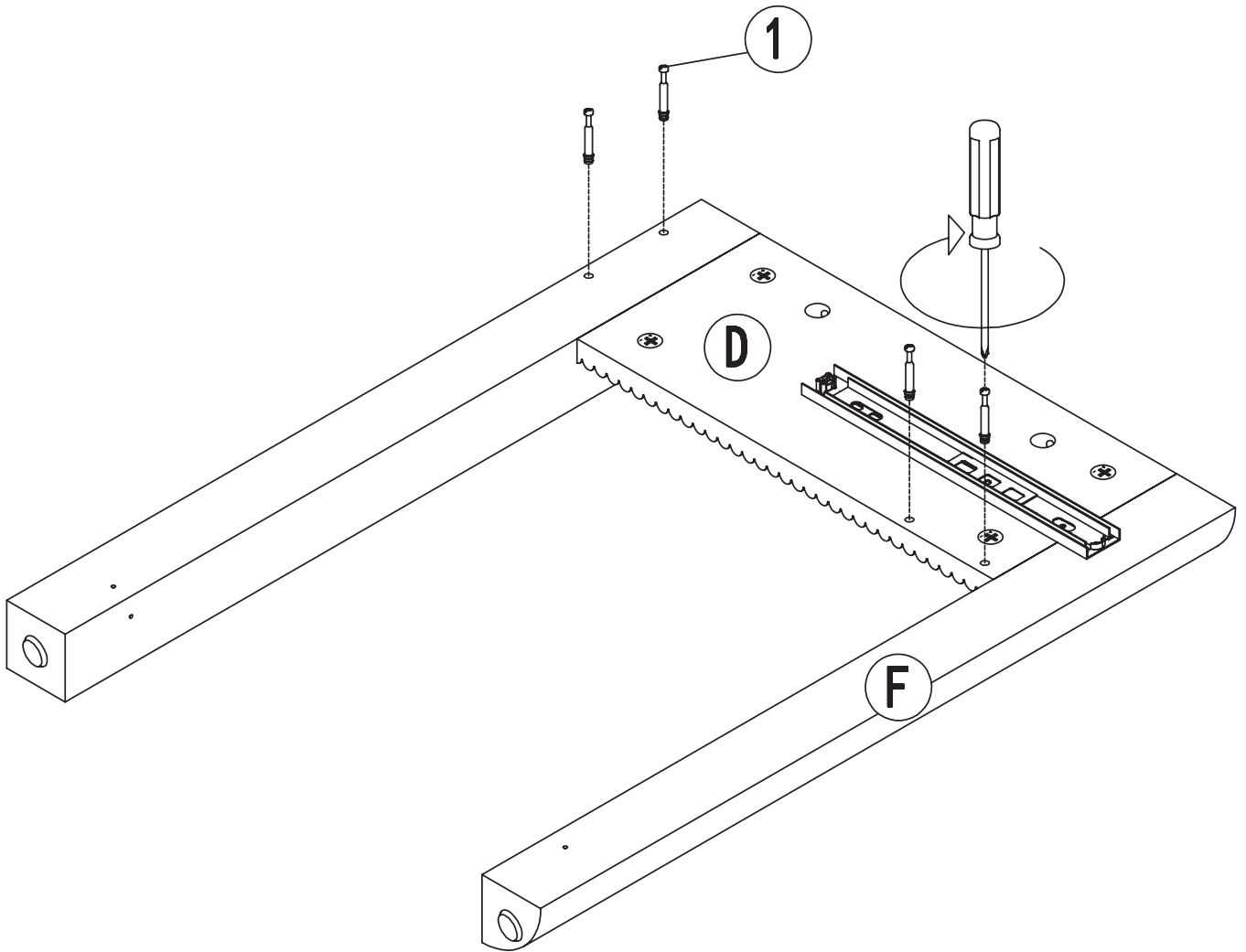
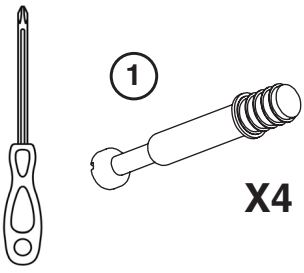

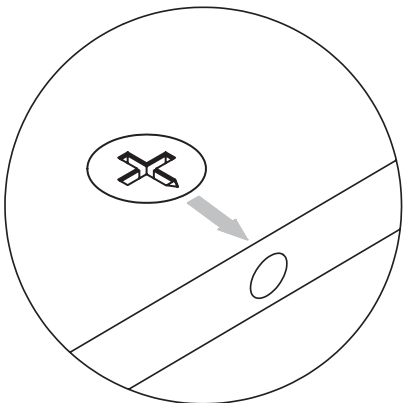
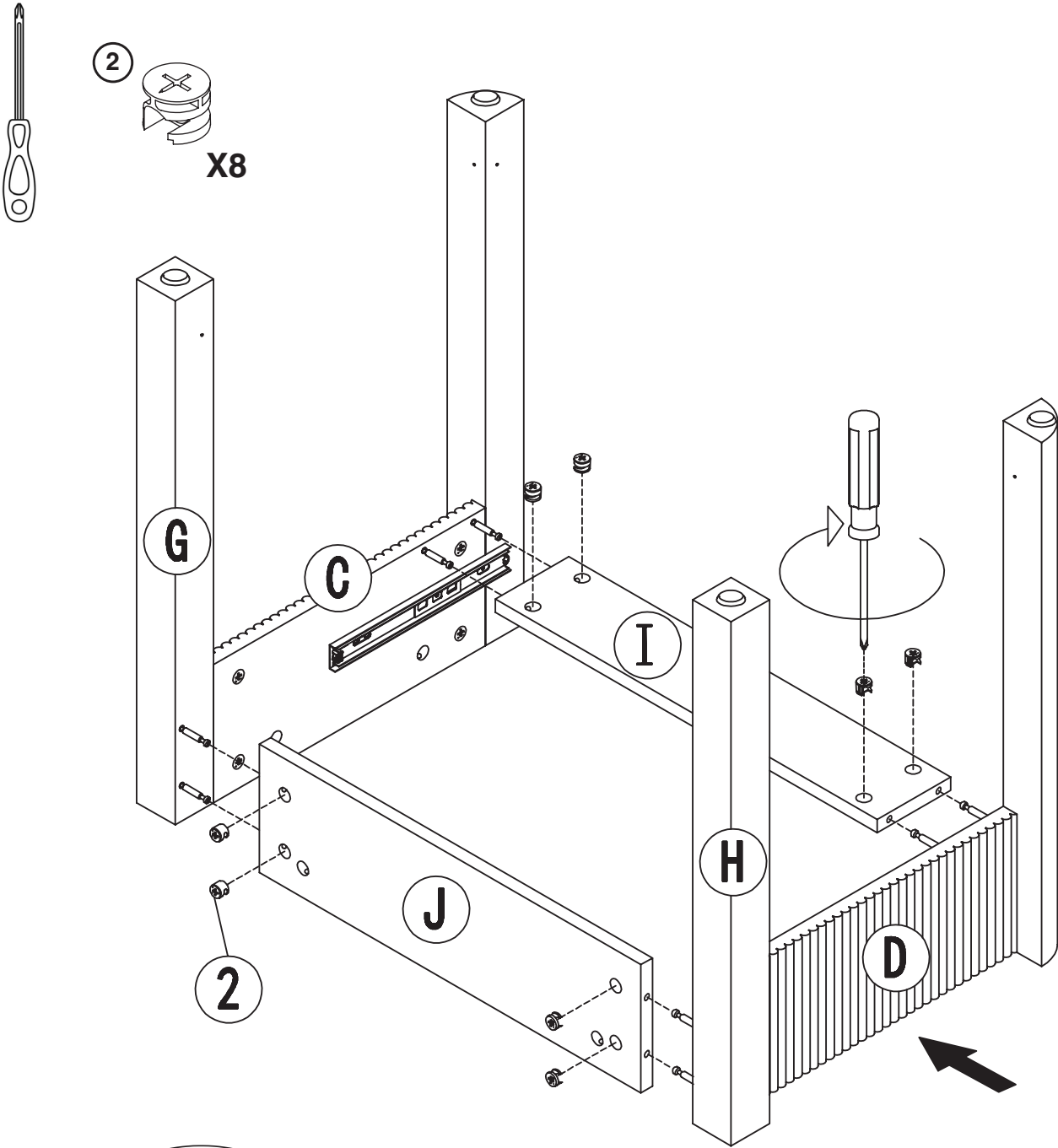

**NOTE:** THE ARROW IN THE CAM LOCK MUST POINT TOWARD THE HOLE.

**REMARQUE :** LA FLÈCHE DANS LE VERROU À CAME DOIT POINTER VERS LE TROU.

**NOTA:** LA FLECHA EN LA CERRADURA DE LEVA DEBE APUNTAR HACIA EL ORIFICIO.

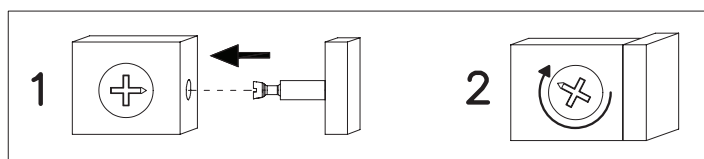

MAKE SURE THE ASSEMBLY IS DONE ON A LEVEL AND SOFT SURFACE (SUCH AS BLANKETS)  
TO PREVENT DAMAGING THE PARTS DURING ASSEMBLY.

ASSUREZ-VOUS QUE L'ASSEMBLAGE EST EFFECTUÉ SUR UNE SURFACE PLANE ET DOUCE  
(COMME DES COUVERTURES) POUR ÉVITER D'ENDOMMAGER LES PIÈCES L'ASSEMBLAGE.

ASEGÚRESE DE QUE EL MONTAJE SE REALICE EN UNA SUPERFICIE NIVELADA Y SUAVE (COMO MANTAS)  
PARA EVITAR DAÑAR LAS PIEZAS DURANTE EL MONTAJE.

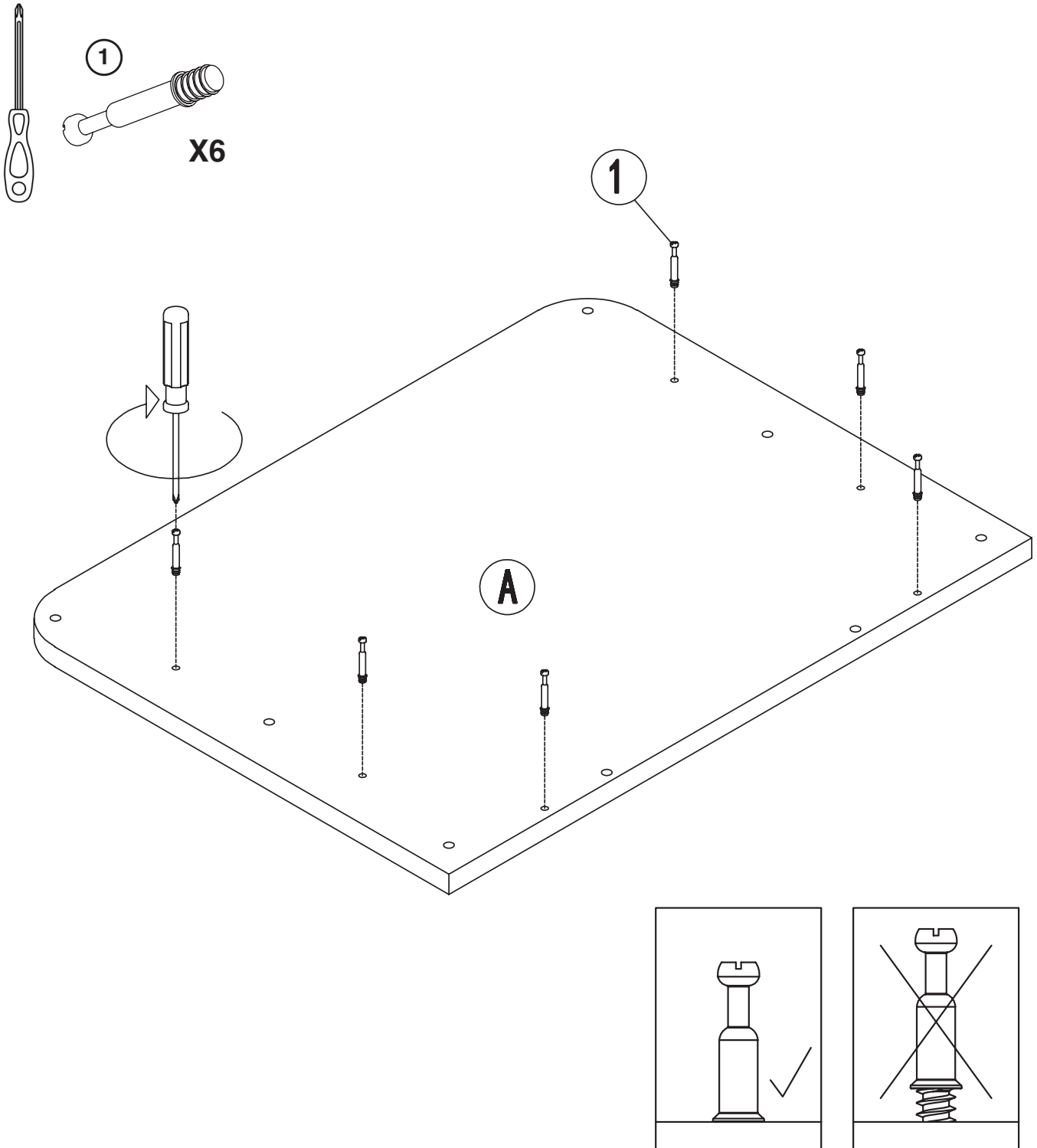

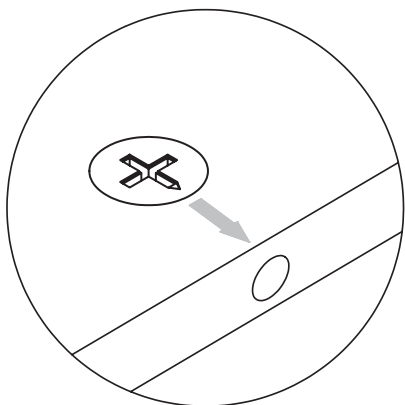
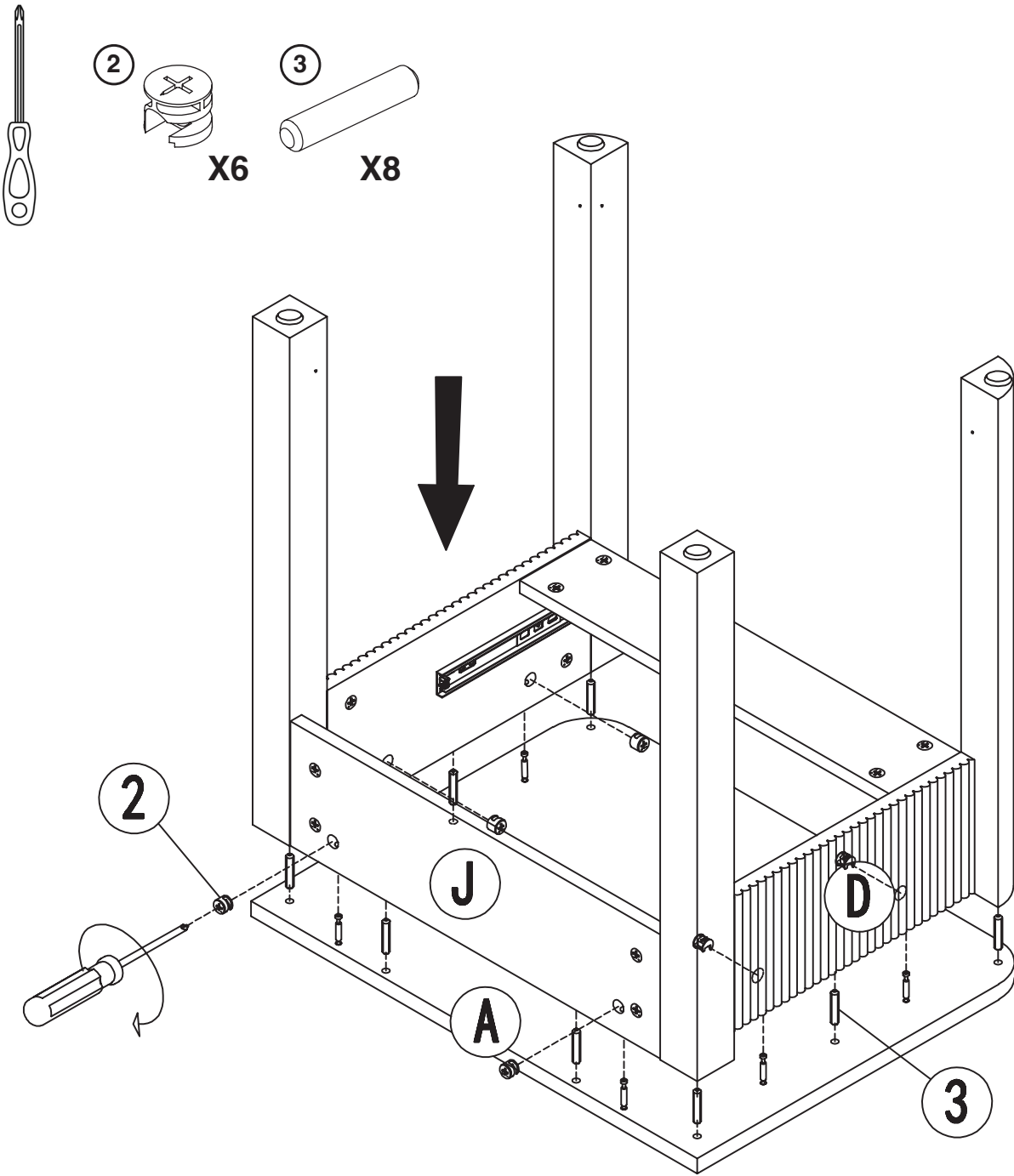

**NOTE: THE ARROW IN THE CAM LOCK MUST POINT TOWARD THE HOLE.**

**REMARQUE : LA FLÈCHE DANS LE VERROU À CAME DOIT POINTER VERS LE TROU.**

**NOTA: LA FLECHA EN LA CERRADURA DE LEVA DEBE APUNTAR HACIA EL ORIFICIO.**

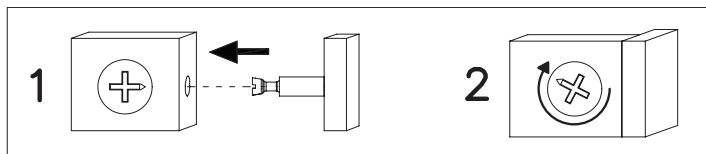

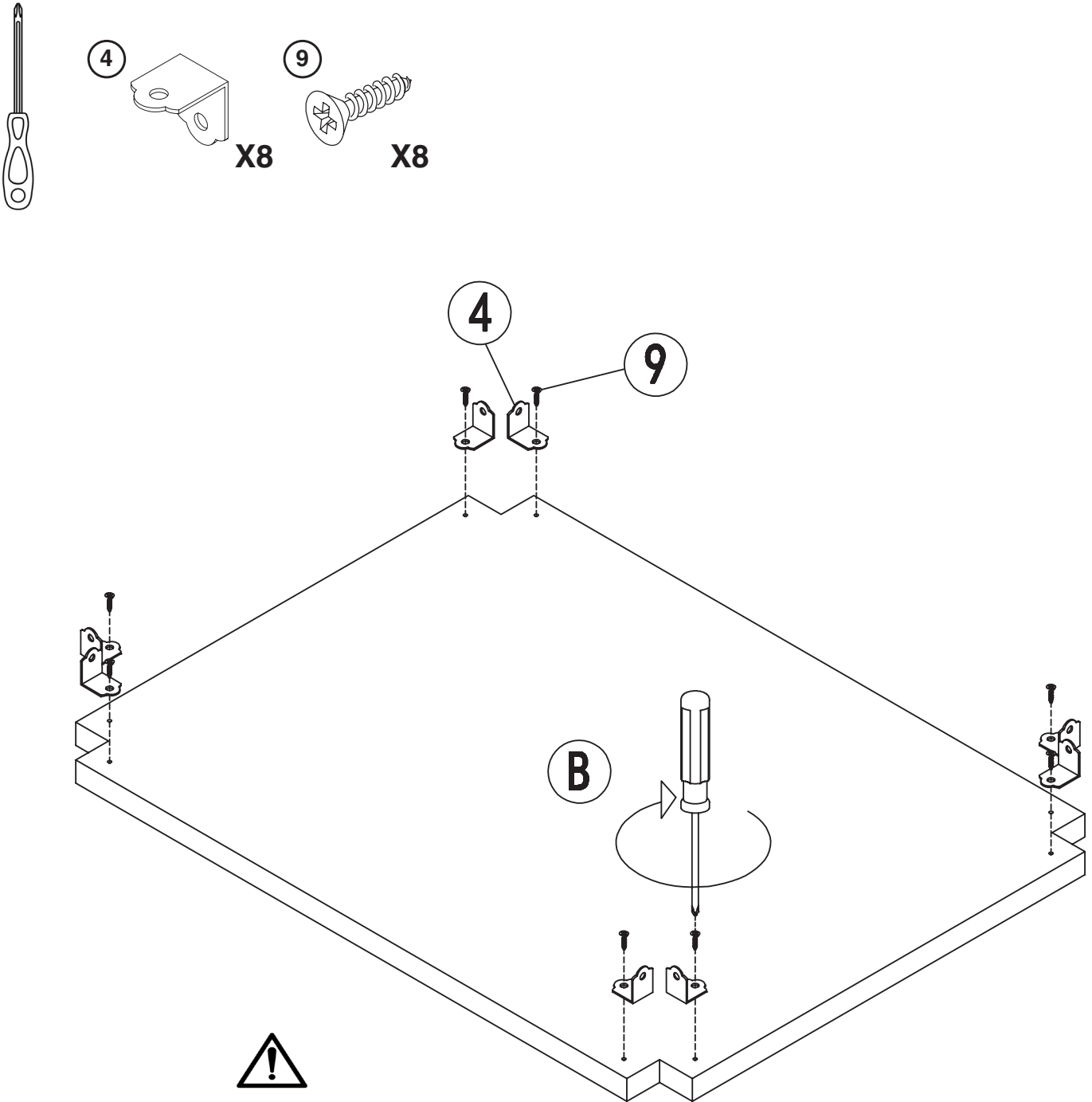

**NOTE: DO NOT OVERTIGHTEN SCREWS.**

**REMARQUE : NE PAS TROP SERRER LES VIS.**

**NOTA: NO APRIETE DEMASIADO LOS TORNILLOS.**

10



*An assistant is recommended to HOLD Part B in place to assemble.*

*Un assistant est recommandé pour MAINTENIR la partie B en place pour l'assemblage.*

*Se recomienda un asistente para SOSTENER la Parte B en su lugar para ensamblar.*

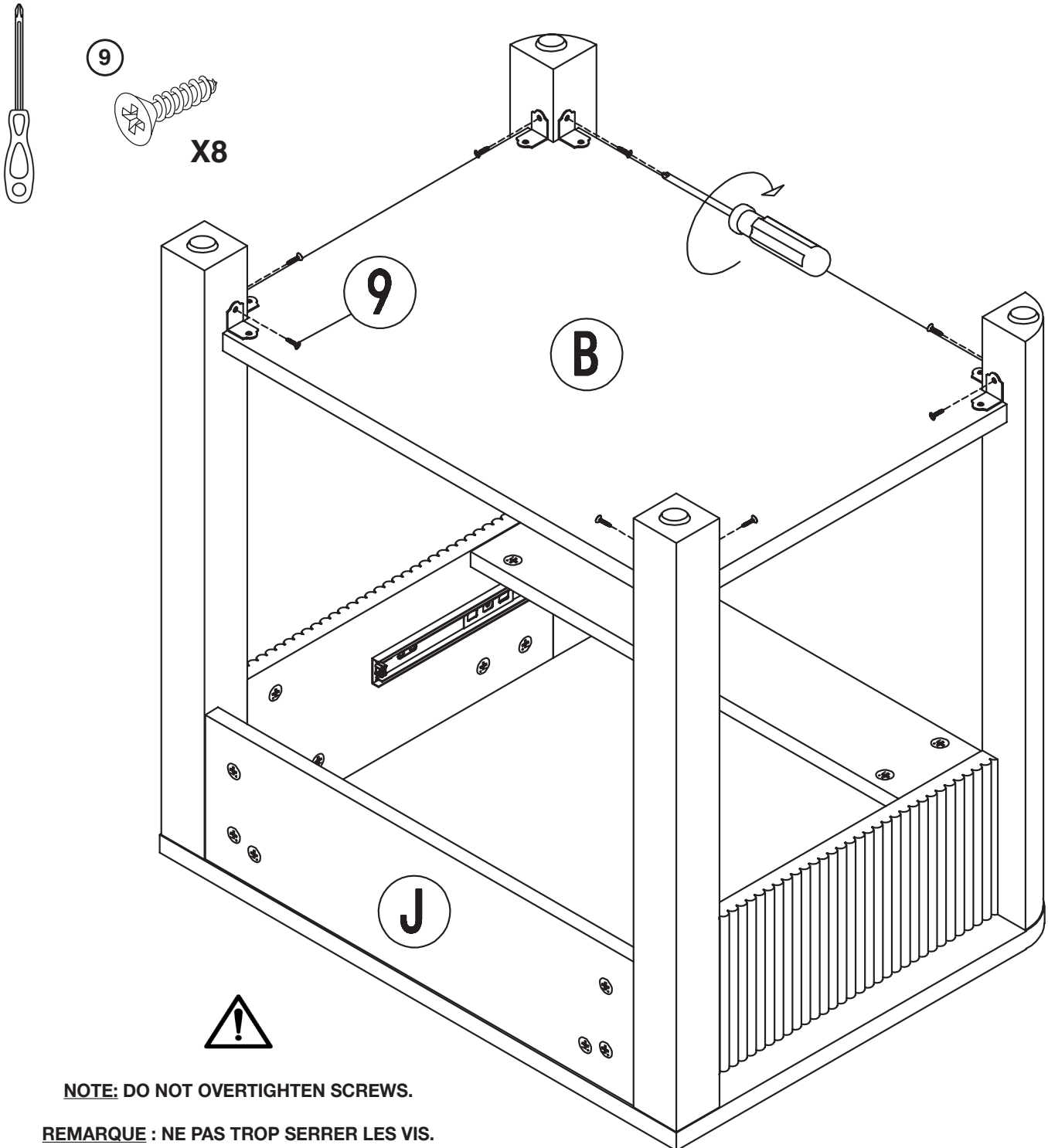

**NOTE: DO NOT OVERTIGHTEN SCREWS.**

**REMARQUE : NE PAS TROP SERRER LES VIS.**

**NOTA: NO APRIETE DEMASIADO LOS TORNILLOS.**

MAKE SURE THE ASSEMBLY IS DONE ON A LEVEL AND SOFT SURFACE (SUCH AS BLANKETS)  
TO PREVENT DAMAGING THE PARTS DURING ASSEMBLY.

ASSUREZ-VOUS QUE L'ASSEMBLAGE EST EFFECTUÉ SUR UNE SURFACE PLANE ET DOUCE  
(COMME DES COUVERTURES) POUR ÉVITER D'ENDOMMAGER LES PIÈCES L'ASSEMBLAGE.

ASEGÚRESE DE QUE EL MONTAJE SE REALICE EN UNA SUPERFICIE NIVELADA Y SUAVE (COMO MANTAS)  
PARA EVITAR DAÑAR LAS PIEZAS DURANTE EL MONTAJE.

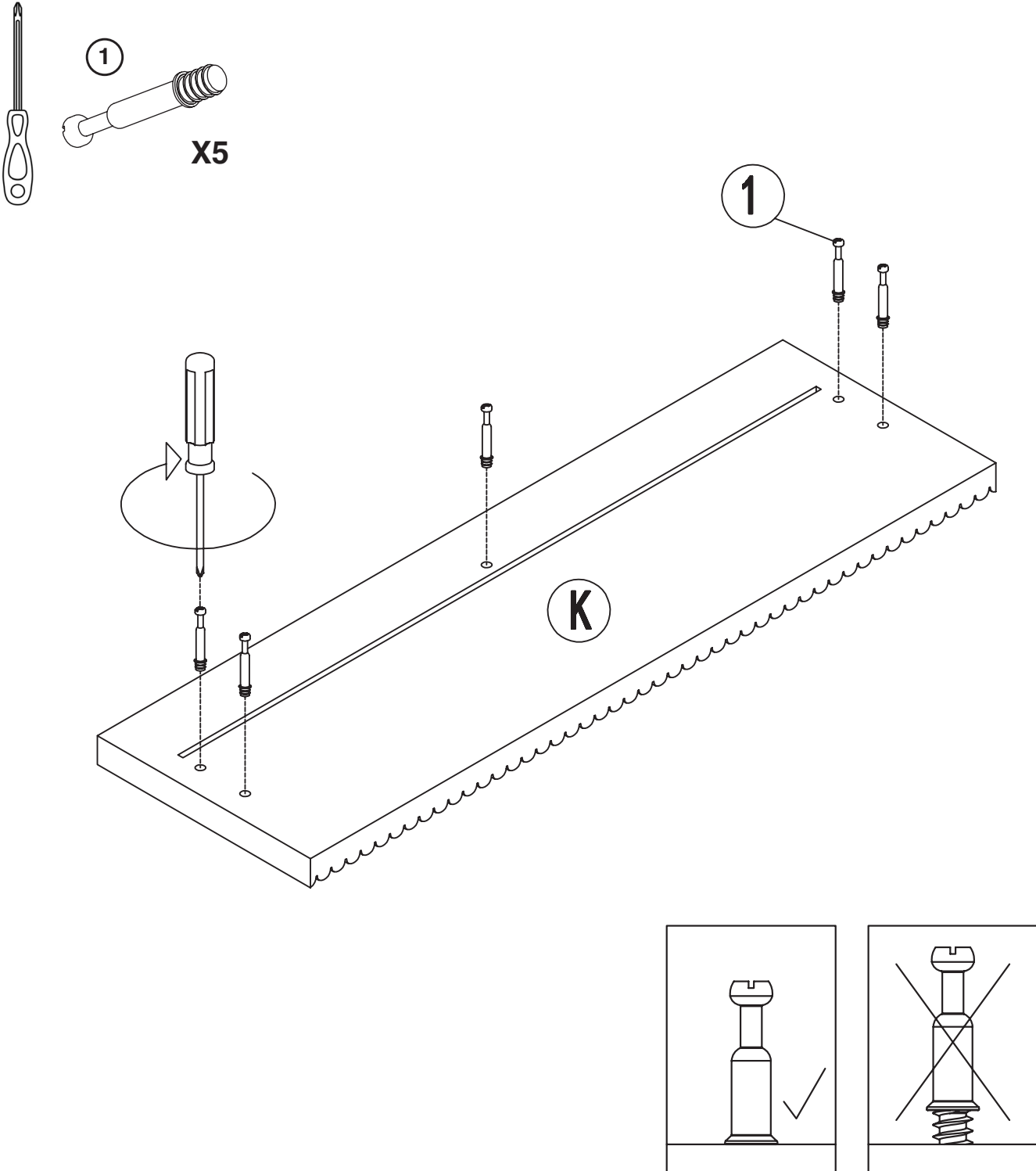

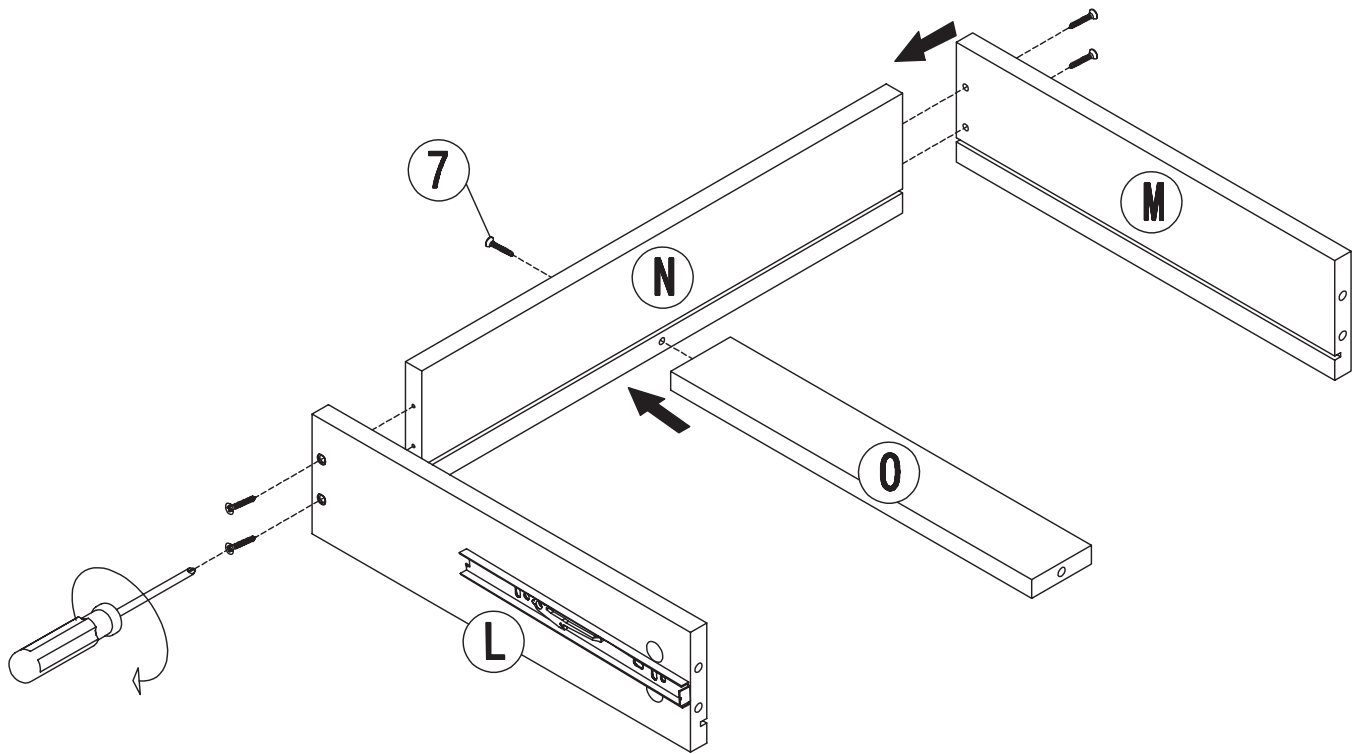
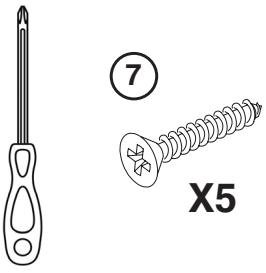

**NOTE: DO NOT OVERTIGHTEN SCREWS.**

**REMARQUE : NE PAS TROP SERRER LES VIS.**

**NOTA: NO APRIETE DEMASIADO LOS TORNILLOS.**

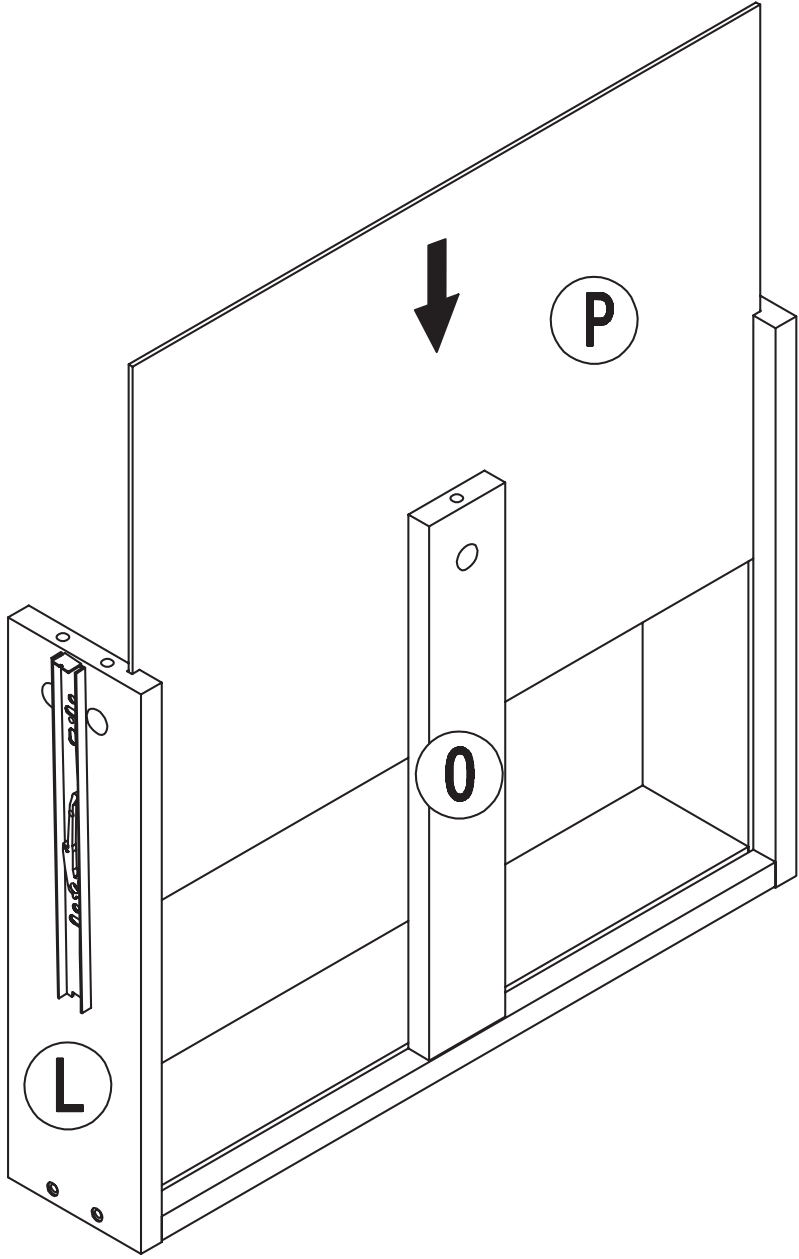

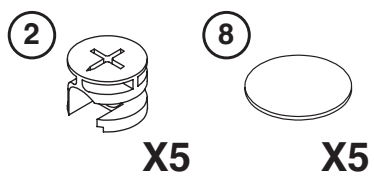

**NOTE: USE STICKERS (8) TO COVER ANY VISIBLE CAM LOCKS.**  
**REMARQUE : UTILISEZ LES AUTOCOLLANTS (8) POUR COUVRIR LES VERROUS À CAME VISIBLES.**  
**NOTA: UTILICE PEGATINAS (8) PARA CUBRIR LOS BLOQUEOS DE LEVA VISIBLES.**

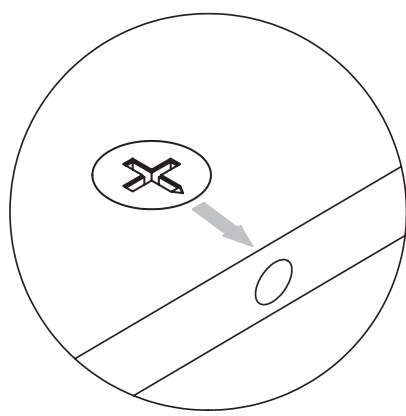
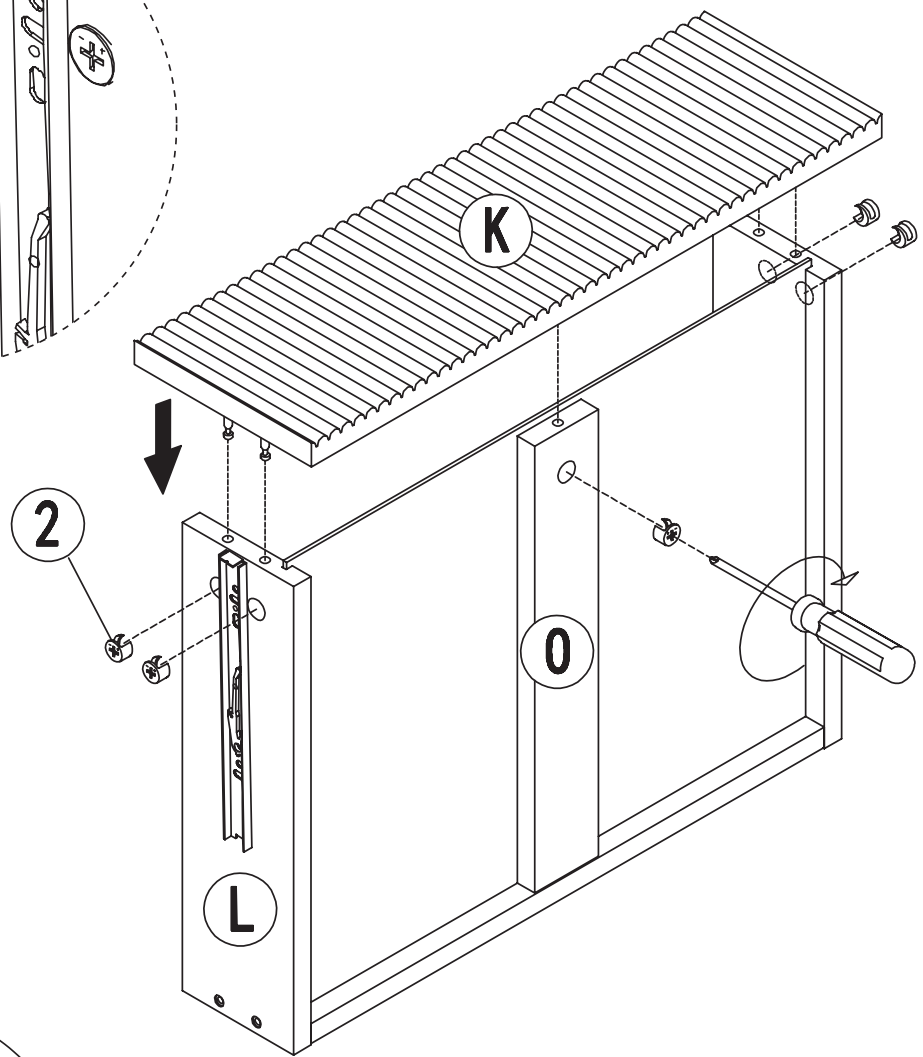
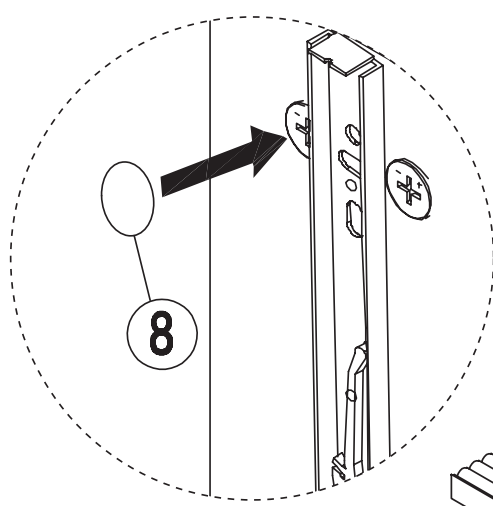

**NOTE: THE ARROW IN THE CAM LOCK MUST POINT TOWARD THE HOLE.**  
**REMARQUE : LA FLÈCHE DANS LE VERROU À CAME DOIT POINTER VERS LE TROU.**  
**NOTA: LA FLECHA EN LA CERRADURA DE LEVA DEBE APUNTAR HACIA EL ORIFICIO.**

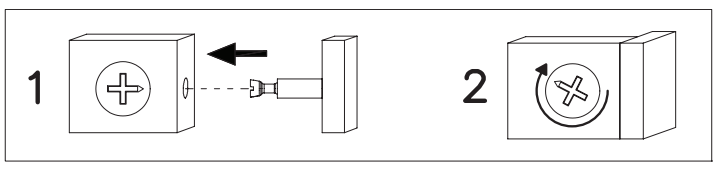

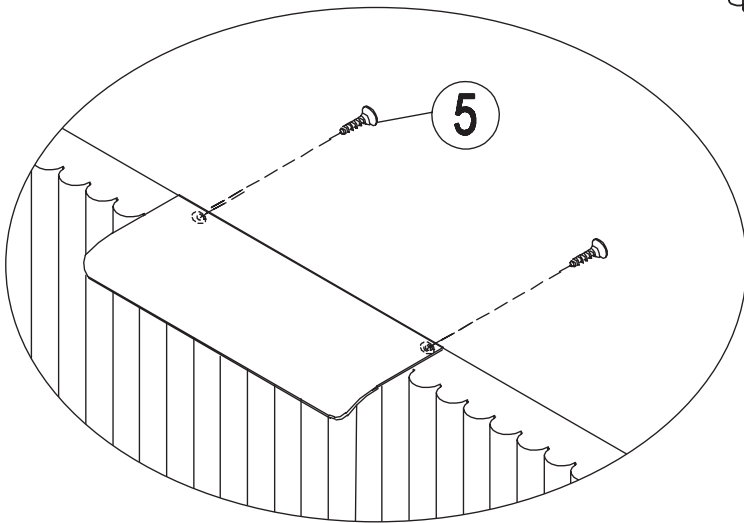
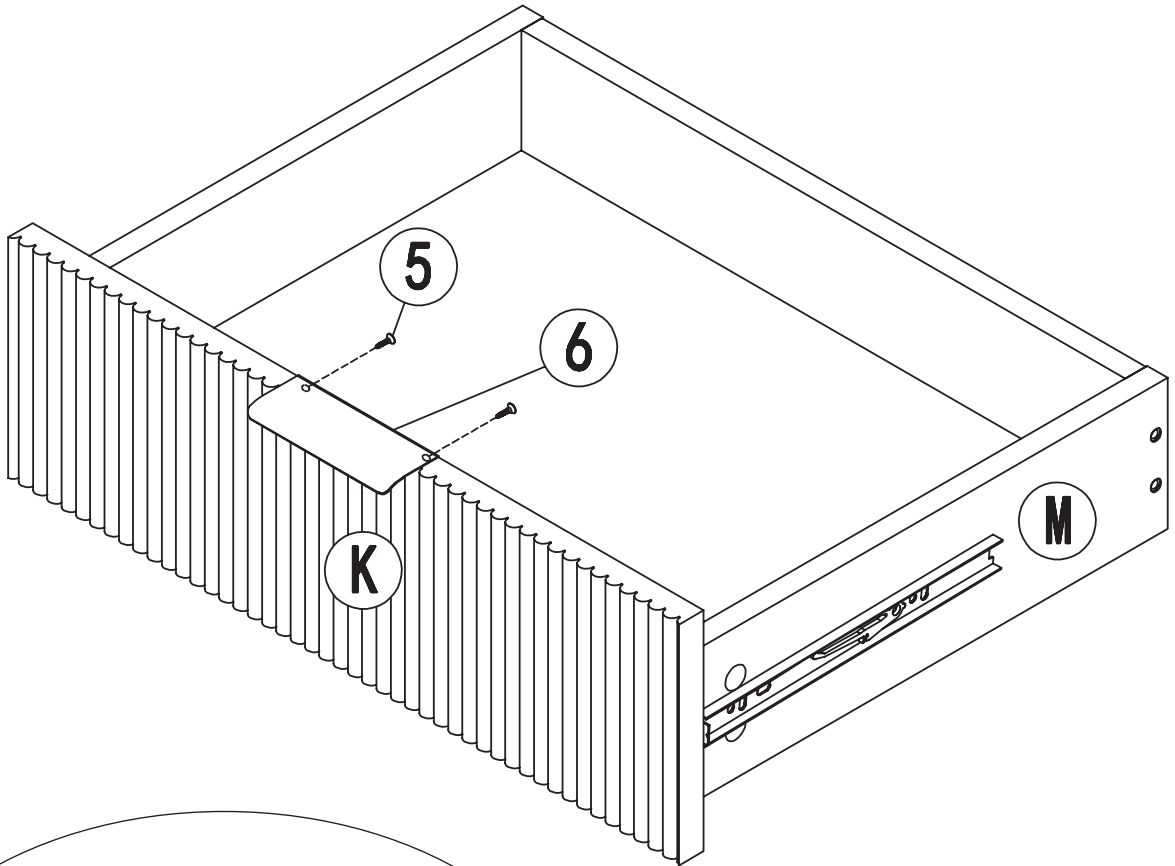
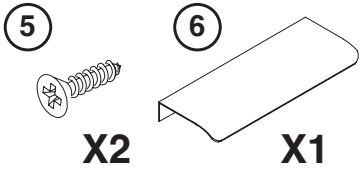

**NOTE: DO NOT OVERTIGHTEN SCREWS.**

**REMARQUE : NE PAS TROP SERRER LES VIS.**

**NOTA: NO APRIETE DEMASIADO LOS TORNILLOS.**



**Carefully slide drawers into the nightstand:**

**Faites glisser soigneusement les tiroirs dans la table de nuit :**

**Deslice con cuidado los cajones hacia la mesa de noche:**

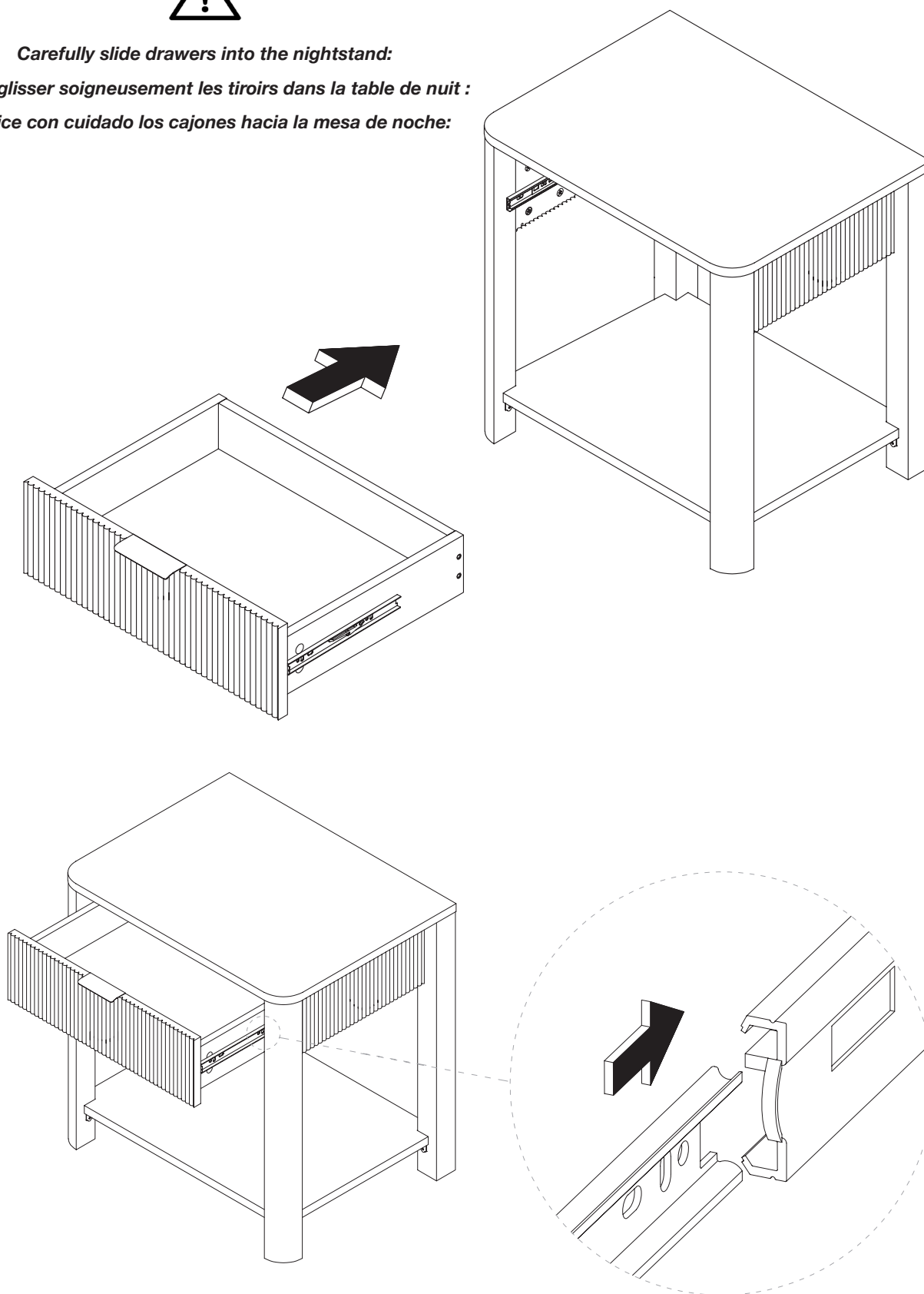



**How to remove the drawers:**  
**Comment retirer les tiroirs :**  
**Cómo quitar los cajones:**

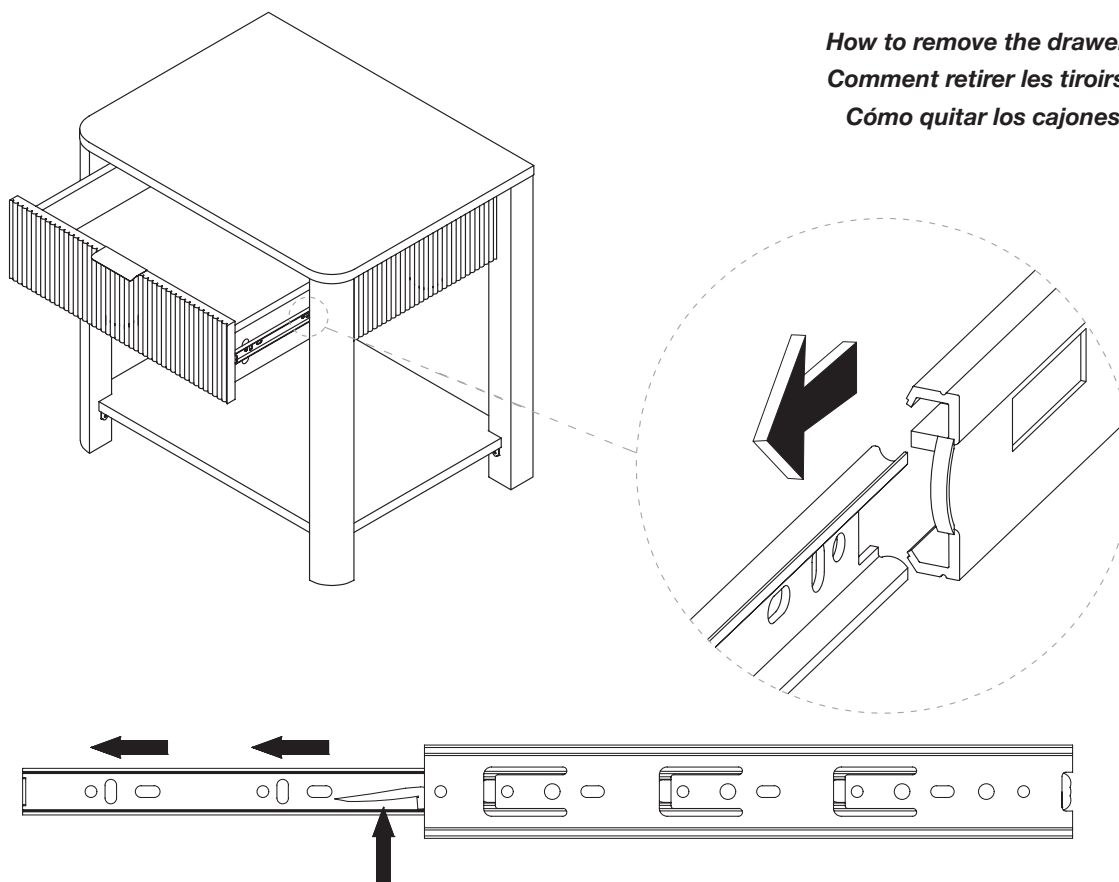

**Press the release mechanism**  
**Appuyez sur le mécanisme de déverrouillage**  
**Presione hacia arriba el mecanismo de liberación**

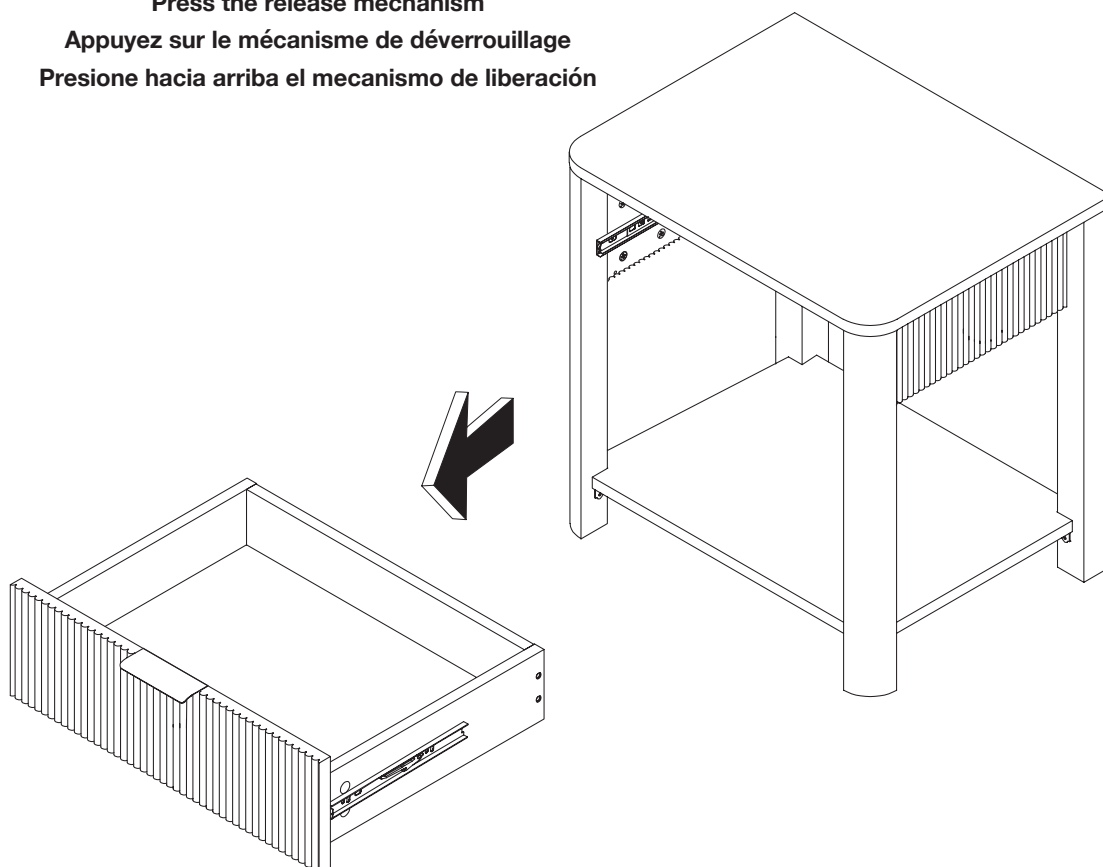

**Finished**  
**Fini**  
**Terminado**

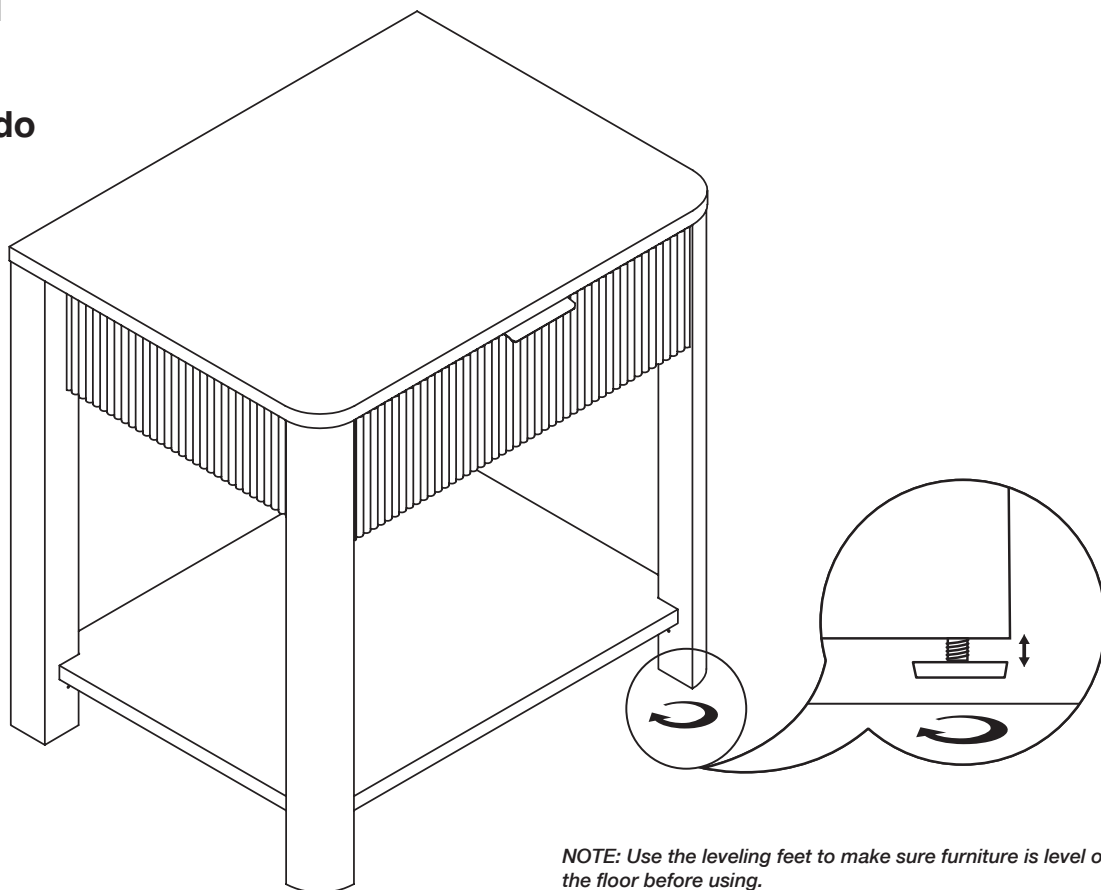

*NOTE: Use the leveling feet to make sure furniture is level on the floor before using.*

*REMARQUE: Utilisez les pieds de nivellement pour vous assurer que les meubles sont à niveau sur le sol avant de les utiliser.*

*NOTA: Use los pies niveladores para asegurarse de que el mueble estén nivelados en el piso antes de usar la mesa.*

---

#### **CARE INSTRUCTIONS:**

- Wipe clean with a soft, dry cloth or static duster.
- Always avoid the use of harsh chemicals or abrasive cleaners as they may cause damage to the table's finish.
- Hardware may loosen over time. Periodically check to make sure all connections are tight. Re-tighten if necessary.

#### **INSTRUCTIONS D'ENTRETIEN :**

- Essayez-le proprement à l'aide d'un chiffon doux et sec ou d'un essuie-meuble statique.
- Évitez toujours d'utiliser des produits chimiques forts ou agents nettoyants abrasifs, car ils pourront endommager la finition de la table basse.
- Le matériel de fixation peut se desserrer avec le temps. Vérifiez régulièrement afin de vous assurer que tous les raccords sont bien serrés. Resserrez-les au besoin.

#### **INSTRUCCIONES DE CUIDADO:**

- Limpie con un paño suave y seco o con un paño para estática.
- Evite siempre el uso de limpiadores químicos ásperos o abrasivos, ya que pueden dañar el acabado de la mesa de café.
- Las piezas de ferretería pueden aflojarse con el tiempo. Controlar periódicamente que estén bien ajustadas. Si es necesario, volver a ajustarlas.