

OWNER'S MANUAL

Model: SK-110-8R (5301052)

(110 Gallon Skid Sprayer w/208cc B&S Engine, 8-Roller Pump & Deluxe Handgun)

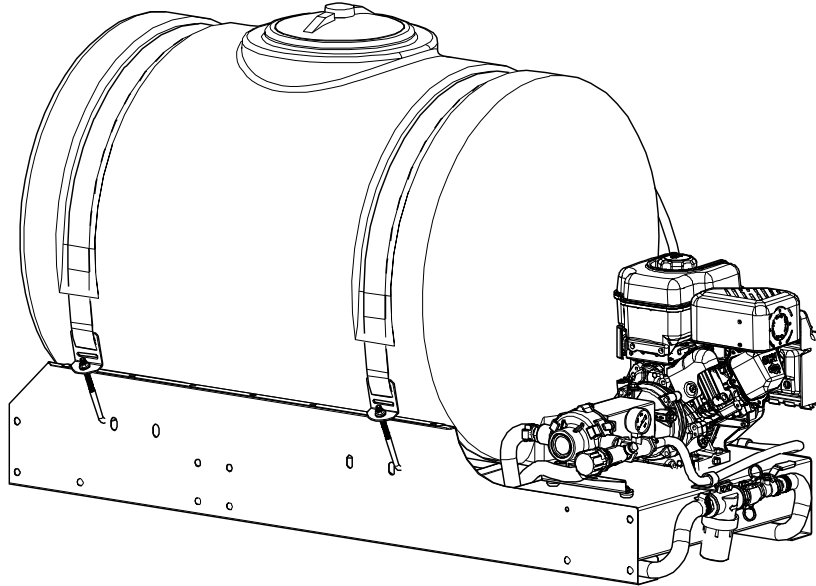

General Information

Thank you for purchasing this product. The purpose of this manual is to assist you in operating and maintaining your skid sprayer.

**BEFORE RETURNING THIS PRODUCT
FOR ANY REASON, PLEASE CALL**

1-800-831-0027

MONDAY-FRIDAY, 8:00 AM TO 5:00 PM CST

If you should have a question or experience a problem with your Fimco Industries Product: Visit our website @ www.fimcoindustries.com or call the Toll free number above. Our technical support representatives will be happy to help you.

In most cases a customer service rep. can resolve the problem over the phone.

To obtain prompt, efficient service, always remember to give the following information....

- Correct Part Description and/or part number
- Model number and Serial Number

Part descriptions and numbers can be obtained from the illustrated parts list section(s) of this manual.



WARNING: Cancer and Reproductive Harm.
www.P65Warnings.ca.gov



WARNING: To reduce the risk of injury, the user must read and understand the operator's manual before using this product.

IMPORTANT REMINDER:

Add proper oil to the engine crankcase and gasoline to the gas tank. Refer to the engine manual for the correct type and amount.

*****WARNING*****

This product when used can be dangerous and can cause bodily harm, if not properly used or guarded.

*** STAY AWAY FROM EQUIPMENT
WHEN IT IS IN OPERATION ***

Read information and the full instructions furnished with the product before installing and operating.

Retain a copy of your receipt for your unit, as it will be required to validate any warranty service.

Warranted against manufacturer or workmanship defects from date of purchase with copy of receipt:

Homeowner Usage: One Year

Commercial Usage: 90 Days.



www.fimcoindustries.com

1000 FIMCO Lane, P.O. Box 1700, North Sioux City, SD 57049
Toll Free Phone: 800-831-0027 : Toll Free Fax: 800-494-0440

[5004502

(11/24)]

Contents

Technical Specs and Assembly Instructions	2	Roller Pump Trouble Shooting	6
Operation	3	Sprayer Exploded Views.....	7 - 8
Maintenance, Tank Care and Winter Storage	4	Sprayer Parts List.....	9
Pressure Relief Valve Exploded View/Parts List	5	Sprayer Dimensions	10
Roller Pump Exploded View/Parts List	5	Warranty	12
Roller Pump Operations/Maintenance	6		

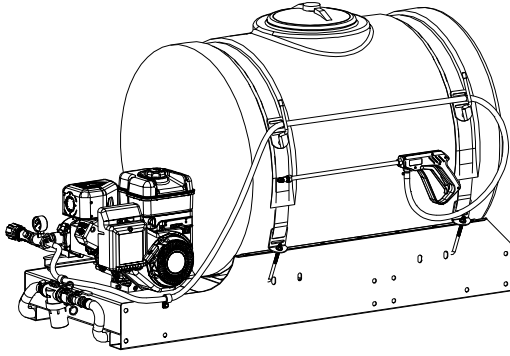

Model: SK-110-8R (5301052) (110 Gallon Skid Sprayer w/208cc B&S Engine, 8-Roller Pump & Deluxe Handgun)

Technical Specifications

- 110 Gallon Polyethylene Tank
- 208cc B&S Engine, 8.0 Gross Torque w/6:1 Gear Reduction
- 8 Roller Pump - 10 GPM @ 250 PSI
- Pressure Relief Valve
- Deluxe Pistol Grip Handgun W/25' of Hose

**Caution: When fully filled with water, this sprayer will weigh approx. 1,155 lbs..
Consult the owner's manual for your vehicle to verify that you are within it's load carrying capacity.**

~~~~~IMPORTANT~~~~~

Remove tank lid and be sure the tank is clean and free of any foreign material. Rinse tank out of any tank residue before filling with water to test.

~~~~~IMPORTANT~~~~~

It is **VERY** important to test this sprayer with plain water before actual spraying is attempted. This will enable you to familiarize yourself with the sprayer and check for leaks without the possibility of losing any expensive chemicals.

~~~~~WARNING~~~~~



Read and Understand the Owner's Manual before using this sprayer. Test and use in accordance to instructions.
Read and Follow chemical label instructions and wear protective gear when filling, using, cleaning and servicing the sprayer.

- Exercise Caution** in vehicle handling when towing/hauling a filled sprayer to avoid loss of control or overturning.
- Keep Sprayer and Spray materials** away from other people, children and pets.
- Do Not Turn on Power** to the sprayer, until ready to spray in order to avoid unintentional spray release.
- Do Not Use** on steep slopes. A full sprayer could cause loss of control or overturn sprayer and vehicle.
- Always operate** up and down a slope, never across the face of a slope.
- Keep all movement on slopes** slow and gradual. Do not make sudden changes in speed, directions or turning. Do not start or stop suddenly when going uphill or downhill.
- Stop on level ground**, set the parking brake and shut off engine before leaving the operator's position for any reason.
- Keep all parts** in good condition and properly installed. Fix damaged or worn parts immediately.
- Caution should be taken** when towing and/or using any sprayer. This sprayer combined with the weight distribution, turning radius and speed of vehicle can result in damage to vehicle and/or sprayer or severe injury or death, if not used properly.
- Improper use of this sprayer or handling of chemicals could result in serious injury or illness, or could cause damage to the environment.**

Assembly Instructions

The sprayer is completely assembled. It is ready to operate after mounting it securely on a truck bed.

- Make sure all hose clamps are tight before testing or spraying for the first time.

~~~~~IMPORTANT REMINDER~~~~~

ADD proper oil to the engine crankcase and gasoline to the gas tank. Always check the oil in the gear box. Remove the plug on the side, oil should be visible. Add oil through the top plug. Refer to the engine manual for the correct type and amount.

****The Sprayer is now ready to TEST w/plain water before actual use****

IMPORTANT: Remove tank lid and be sure the tank is clean and free of any foreign material. Rinse tank out of any tank residue before filling with water to test.

Information About the Sprayer

Roller pumps are positive displacement pumps, which means that the entire solution being pumped must go somewhere or the pump will break. In this roller pumping system, solution is drawn from the tank and forced to a planned source, such as a handgun. The pressure is controlled by a pressure relief valve, which is a spring-loaded device that controls the amount of fluid bypassed (recirculated) to the tank. The gray adjusting cap is to be tightened to increase pressure and loosened to decrease pressure.

Testing the Sprayer/Operation

NOTE:

It is important to test this sprayer for leakage and proper spray patterns with plain water before chemical application is attempted. This will also give you the opportunity to familiarize yourself with the operation of the sprayer, without the possibility of losing any expensive chemicals.

1. Fill the tank about 1/2 full with plain water.

Only fill the tank with what you're going to spray in a day, never leave chemicals sit in tank.

2. Open the valve in the suction line (See Detail A) and allow water to flow to the pump. The valve is located at this point to enable the strainer to be taken apart for cleaning, while solution remains in the tank.

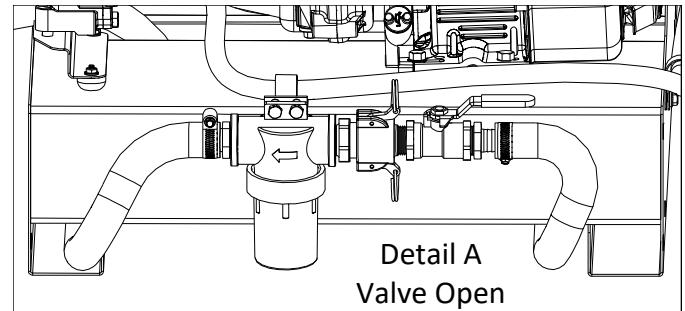

CAUTION: Always be sure that the water (or solution) has reached the roller pump before starting your sprayer. If the pump is allowed to run dry, serious damage to the pump will result. Do not run your sprayer with the boom/handgun line closed AND the bypass line closed. Doing this will damage the pump.

3. It is always best to start the sprayer at little or no pressure. This sprayer is equipped with a spring loaded pressure relief/bypass valve. Turn the valve knob out to decrease pressure and in for increased pressure.

The bypass valve is the “pressure control” for the entire plumbing system. The more the valve is open, the lower your line pressure. Almost fully closed provides maximum pressure to your boom and/or handgun. **NEVER run your system with this valve 100% closed.**

4. You may now start the sprayer engine following the engine manufacturers instructions. Let the sprayer run at low pressure until water has reached the handgun and all air has been purged from the system.

Caution: Care must be taken, being sure the handgun is secured in the operators hand. If this is not done a recoiling action may occur causing damage or personal injury.

5. The pressure should now be increased to 30 - 40 PSI. Operate the sprayer at this increased pressure for 3 to 5 minutes, thoroughly testing the unit before adding chemicals.

When everything tests all right (no leaks and good pressure), add the desired chemicals to the mixture and water combination and start your spraying operation. Adjust the pressure and spray as you did in the testing procedure. The sprayer should now be ready to use.

Conditions of weather and terrain must be considered when setting the sprayer. Do not spray on windy days. Protective clothing must be worn in some cases

Be sure to read the chemical label(s) before application!

Priming the pump

To help prime the pump, keep the inlet or suction line as short as possible with a minimum of bends, elbows and kinks. Make sure all connections are tight and do not leak air. Make sure the line strainer is free of debris. If pump does not self-prime, disconnect suction hose, fill with water and reconnect to liquid source. Often a squirt of oil into the ports of the pump will seal clearances and help priming. Facing the pump, the suction port is on your left.

Maintenance During/After Spraying

Periodically close the suction line valve and check the line strainer and clean the screen. Stop the engine and shut off the valve near the strainer. Remove the bowl and screen portions of the strainer and wash them free from all impurities. You may also drain the tank by uncoupling the suction line near the strainer. Open the valve and pour the contents into another container. Read the chemical label for disposal instructions.

Proper care and maintenance will keep your pump wear at a minimum and will keep it running smoothly and trouble-free for a long time and prolong the life of your sprayer.

After use, fill the sprayer tank part way with water. Start the sprayer and allow the water to pump through the entire plumbing system and nozzles. Drain and then refill half full with plain water, add the recommended amount of good quality tank cleaner such as FIMCO Sprayer Tank Neutralizer and Cleaner. (If no tank cleaner is available, you may substitute dish soap for this step, about 1-2 oz. per gallon). Turn sprayer on and circulate through system for 15 minutes and then spray out through handgun nozzle (and boom nozzles if applicable). Refill tank half way with clean water and repeat. Follow the chemical manufacturer's disposal instructions of all wash or rinsing water.

For the boom (if applicable) remove the tips and screens from the nozzle assemblies. Wash these items out thoroughly. Blow the orifice clean and dry. If the orifice remains clogged, clean it with a fine bristle (NOT WIRE) brush or with a toothpick. Do not damage the orifice. Water rinse and dry the tips before storing.

Flush the pump after each use. One of the common causes of faulty pump performance is "gumming" or corrosion inside the pump. This prevents the rollers from moving freely. Flush the pump with a solution that will neutralize liquid pumped. A rust inhibitor can also be squirted into the ports of the pump. Turn shaft several times to draw protective liquid through pump and coat entire inner surface.

WARNING: Never pump corrosive or abrasive liquids as these will cause rapid wear or deterioration of body, rotor, shaft and seals in the pump. Never run pump dry. Some chemicals will damage the pump valves if allowed to soak untreated for a length of time! ALWAYS flush the pump as instructed after each use. DO NOT allow chemicals to sit in the pump for extended times of idleness. Failure to follow this warning will void the product warranty.

Follow the chemical manufacturer's instructions on disposal of all waste water from the sprayer.

Tank Care & Maintenance

Warning: Do not use the tank as a container for fuel oils, kerosene, gasoline or any other petroleum distillate product. All polyolefins are softened and permeated by such products. In an enclosed area the vaporization of these materials from the outside surface of the tank could create a dangerous condition.

The tank should not be used as a pressure vessel nor used with chemicals or solutions having a weight of more than 12 pounds per gallon.

Store the tank in a dry dark place when not in use. Storage out of sunlight will prolong the life of the tank.

Do not drop, strike or kick the tank, especially at low temperatures. Tanks become brittle and are subject to cracking at temperatures below 20° Fahrenheit.

Always flush the tank with water and a neutralizing agent at the end of each use, to prevent contamination of solutions.

Winter Storage

Prepare the sprayer for end-of-season storage by draining all water out of your sprayer, paying special attention to the pump, handgun and valve(s). These items are especially prone to damage from chemicals and freezing weather.

The sprayer should be winterized before storage by pumping a solution of automotive antifreeze (containing a rust inhibitor) through the entire plumbing system. This antifreeze solution should remain in the plumbing system during the winter months.

When spring time comes and you are preparing your sprayer for the spray season, rinse the entire plumbing system out, clearing the lines of the antifreeze solution.

Proper care and maintenance will prolong the life of your sprayer.

It is nearly impossible to drain all of the water from the sprayer and any trapped water can freeze in cold weather and damage parts of the sprayer. Pumping the antifreeze through the system will displace the water and help prevent this damage.

Strap/Buckle Detail

Strap Attachment to a "Bent" Buckle

The nylon straps are to be inserted in and out of the slots in the buckle, as shown. Be sure the straps are snug before tightening the hook bolts. In most cases, it will be necessary to re-tighten the straps after filling the tank with liquid.

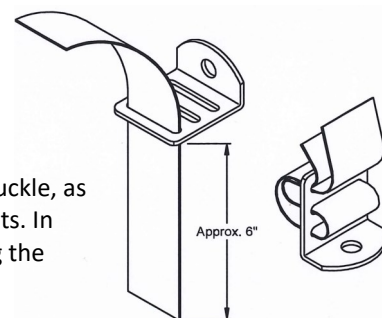

Piston Type Pressure Relief/Regulating Valves

Bypasses excess fluid. Adjustable to maintain control of line pressure at any pressure within the valve operating range.
Selected pressure setting firmly held in place by locknut. Extra large passages to handle large flows.

- Polypropylene with stainless steel spring
- Excellent chemical resistance
- EPDM O-Rings
- Fore pressure to 150 p.s.i.
- 1/4" port for pressure gauge
- 3/4" NPT (M) inlet & (F) outlet connections

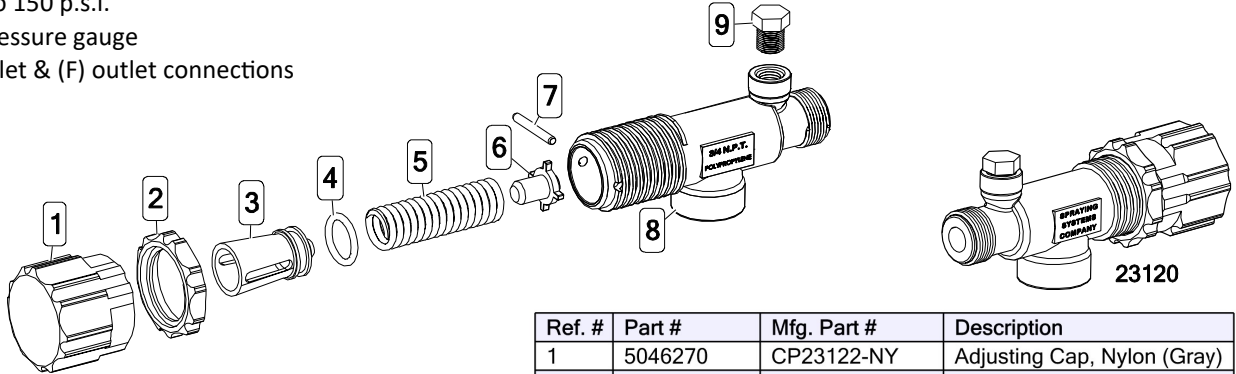

Ref. #	Part #	Mfg. Part #	Description
1	5143199	23120-3/4-PP	Pressure Relief Valve, (3/4" NPT)
2	5168717	PK-AB23120-KIT	Repair Kit, Items Marked **

Ref. #	Part #	Mfg. Part #	Description
1	5046270	CP23122-NY	Adjusting Cap, Nylon (Gray)
2	5110266	CP23123-PP	Lock Ring
3	◆◆	CP23124-PP	Spring Retainer
4	**	CP7717-15-EPR	O-Ring, EPDM Rubber
5	**	CP23127-302SS	Spring
6	◆◆	CP23125-PP	Guide Seat
7	**	CP23126-302SS	Retaining Pin
8	CP23121-PP	CP23121-PP	Poly Body (3/4" NPT)
9	5102022	F14	Pipe Plug, 1/4" MNPT

** Available only in Repair Kit #5168717 (PK-AB23120-KIT)
◆◆ Only Available in Complete Assembly

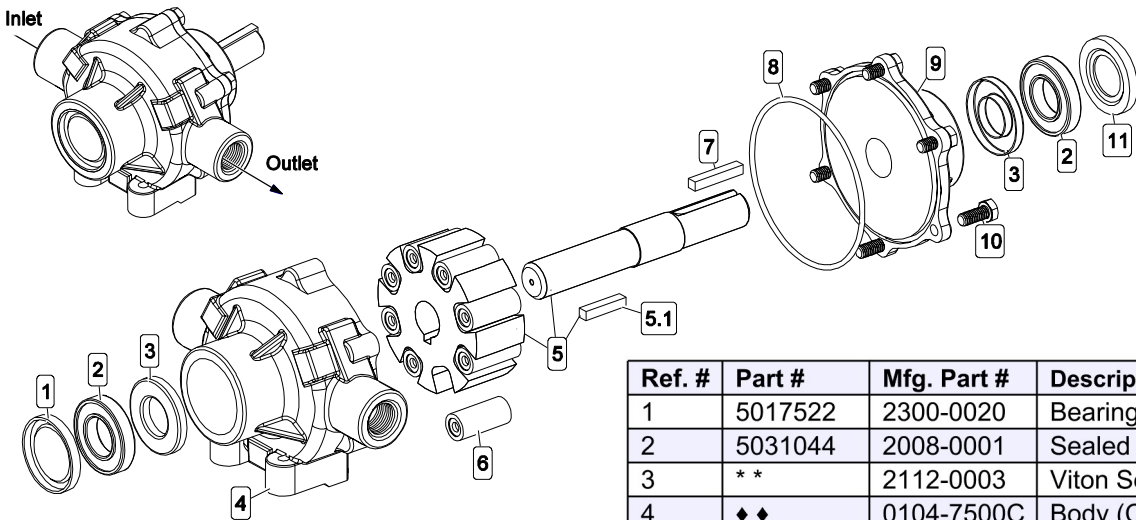

STOP WARNING STOP

DO NOT USE PUMP IN AN EXPLOSIVE ENVIRONMENT. DO NOT USE TO PUMP FLAMMABLE/COMBUSTIBLE FLUIDS, GASOLINE, KEROSENE, FUEL, OIL, ETC.

Cast Iron 8-Roller Pump Assembly #5271509 (Hypro Mfg. Part #: 7560C-R-01)

** Available only in Repair Kit #7771794 (3430-0381)

◆◆ Only Available in Complete Assembly

Ref. #	Part #	Mfg. Part #	Description	Qty
1	5017522	2300-0020	Bearing Cover	1
2	5031044	2008-0001	Sealed Ball Bearing	2
3	**	2112-0003	Viton Seal (Standard)	2
4	◆◆	0104-7500C	Body (Cast Iron) w/Seal	1
5	5172113	0308-7560C	Rotor w/Shaft Assembly	1
5.1	1610-0059	1610-0059	Key (Stainless Steel)	1
6	5112030	1005-0004	Super Roller (Standard)	8
7	5089012	1610-0005	Key	1
8	**	1720-0014	O-Ring Gasket for Endplate	1
9	◆◆	0204-7500C	Endplate (Cast Iron) w/Seal	1
10	5034038	- - -	H.H.C.S. 5/16"-18nc x 3/4"	6
11	5017523	2300-0022	Shaft Bearing Cover	1

Pump Speed (RPM)	0 PSI		50 PSI		100 PSI		150 PSI		200 PSI		250 PSI		300 PSI	
	GPM	HP	GPM	HP	GPM	HP	GPM	HP	GPM	HP	GPM	HP	GPM	HP
600	14.0	0.45	13.1	0.87	12.1	1.41	11.2	1.98	10.6	2.5	10.0	3.1	9.1	3.7

Roller Pump General Safety Information

1. Use a pressure relief device on the discharge side of the pump to prevent damage from pressure buildup when the pump discharge is blocked or otherwise closed and the power source is still running.
2. **WARNING:** Never pump flammable or explosive fluids such as gasoline, fuel oil, kerosene, etc. Never use in explosive atmospheres. The pump should be used only with liquids compatible with the pump component materials. Failure to follow this warning can result in personal injury and/or property damage and will void the product warranty.
3. Never pump acids (i.e. acid fertilizer) with Super Rollers!
4. Never run the pump faster than maximum recommended speed.
5. Never pump at pressures higher than the maximum recommended pressure.
6. Never pump liquids at temperatures higher than the recommended maximum temperatures (140°F/60°C).
7. Make certain that the power source conforms to the requirements of your equipment.
8. Provide adequate protection in guarding around the moving parts such as the shaft and pulleys.
9. Disconnect power before servicing.
10. Release all pressure within the system before servicing any component.
11. Drain all liquids from the system before servicing any component.
12. Check all hoses for weak or worn condition before each use. Make certain that all connections are tight and secure.
13. Periodically inspect the pump and the system components. Perform routine maintenance as required.
14. Never operate a gasoline engine in an enclosed area. Be sure the area is well ventilated.
15. Use only pipe, hose and fittings rated for the maximum psi rating of the pump.
16. Never use pump for pumping water or other liquids for human or animal consumption.

Roller Pump Operation & Maintenance

WARNING: Never pump corrosive or abrasive liquids as these will cause rapid wear or deterioration of the body, rotor, shaft and seals in the pump. The pump should be used on with liquids compatible with pump component materials. Never exceed maximum specified rpm and pressure. Never run pump dry. Failure to follow this warning will void the product warranty.

Priming the Pump:

To help prime the pump, keep the inlet or suction line as short as possible with a minimum of bends, elbows and kinks. Make sure all connections are tight and do not leak air. Make sure line strainer is free of debris. If pump does not self-prime, disconnect suction hose, fill with water and reconnect to liquid source. Often a squirt of oil into the ports of the pump will seal clearance and help priming.

Care of the Pump:

Proper care and maintenance will keep your pump wear at a minimum and will keep it running smoothly and trouble-free for a long time.

Flush the Pump After Each Use

One of the common causes of faulty pump performance is “gumming” or corrosion inside the pump. This prevents rollers from moving freely in their rotor slots. Flush the pump with a solution that will neutralize liquid pumped, mixed according to manufacturer’s directions.

To Prevent Corrosion:

After cleaning pump as above, flush it with a 50-50 solution of permanent-type automotive antifreeze (containing a rust inhibitor) and water. A rust inhibitor can also be squirted into the ports of the pump. Turn shaft several times to draw protective liquid through pump and coat entire inner surface. Drain pump and plug ports to keep out air during storage. For short periods of idleness, noncorrosive liquids may be left in the pump, but air must be kept out. Plug ports or seal port connections.

Troubleshooting		
Symptom	Probable Cause(s)	Corrective Action
Pump Does Not Prime	Leak in suction line	Check hose and fittings for leaks and correct
	Obstruction in suction line	Inspect hose for debris or loose inner liner in hose
	Suction hose sucked to bottom or side of tank	Cut a notch or "V" in end of suction hose
	Rollers stuck in pump	Disassemble pump and inspect rollers
	Pump seals leaking air	Replace seals
Loss of Pressure	Clogged suction strainer	Check strainer and clean it regularly
	Kinked or blocked suction hose	Inspect suction hose and repair as necessary
	Air leak in inlet side plumbing	Check hose and connections for leaks Use pipe joint sealant and retighten connections
	Relief valve setting too low or weakened spring	Check relief valve and correct setting
	Faulty Gauge	Replace gauge
	Pump seals leak air	Replace seals
	Nozzle orifices worn	Replace nozzles
Pump worn	Repair pump	
Pump will not turn	Corrosion (rust), scale or residue	Loosen endplate bolts. Squirt oil into ports to help free rotor. Retighten bolts.
	Solid object lodged in pump.	Disassemble pump and remove objects

Exploded View SK-110-8R (5301052)

Refer to Parts List
next page
for Part Numbers

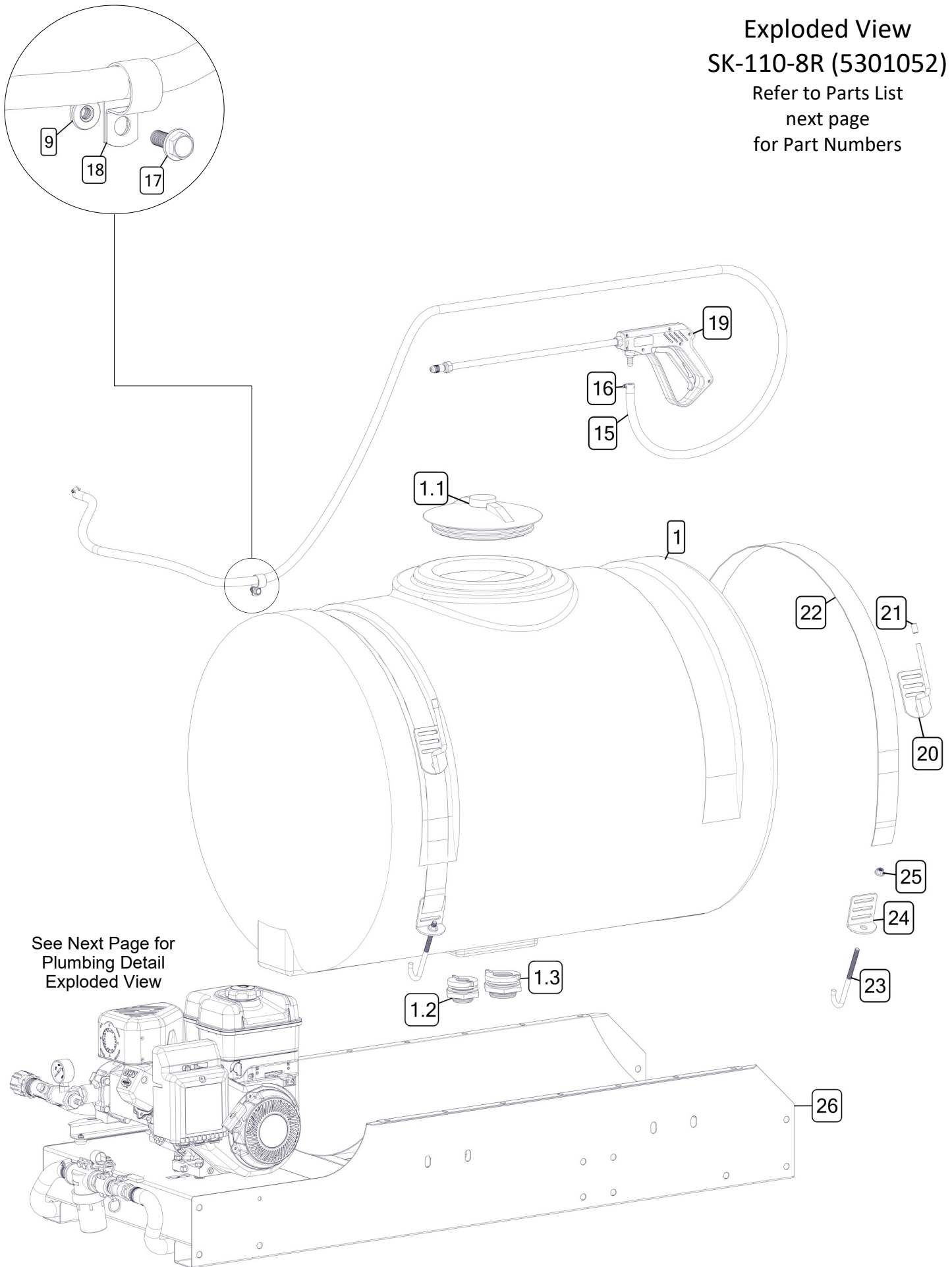

See Next Page for
Plumbing Detail
Exploded View

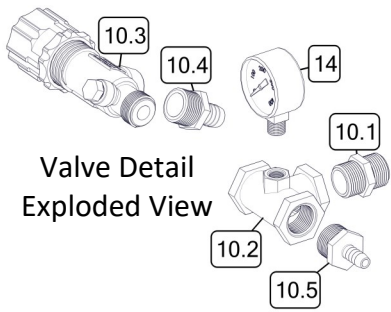

Engine/Pump Detail Exploded View

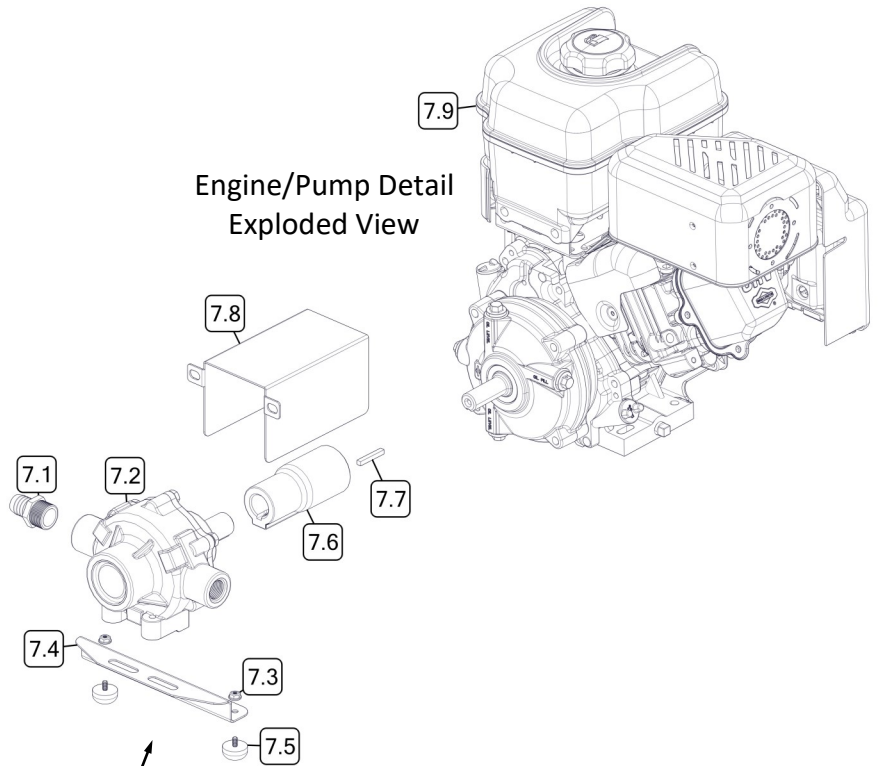

Plumbing Detail Exploded View

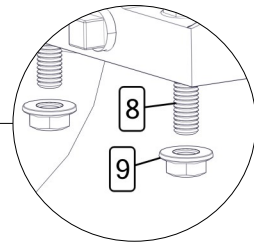
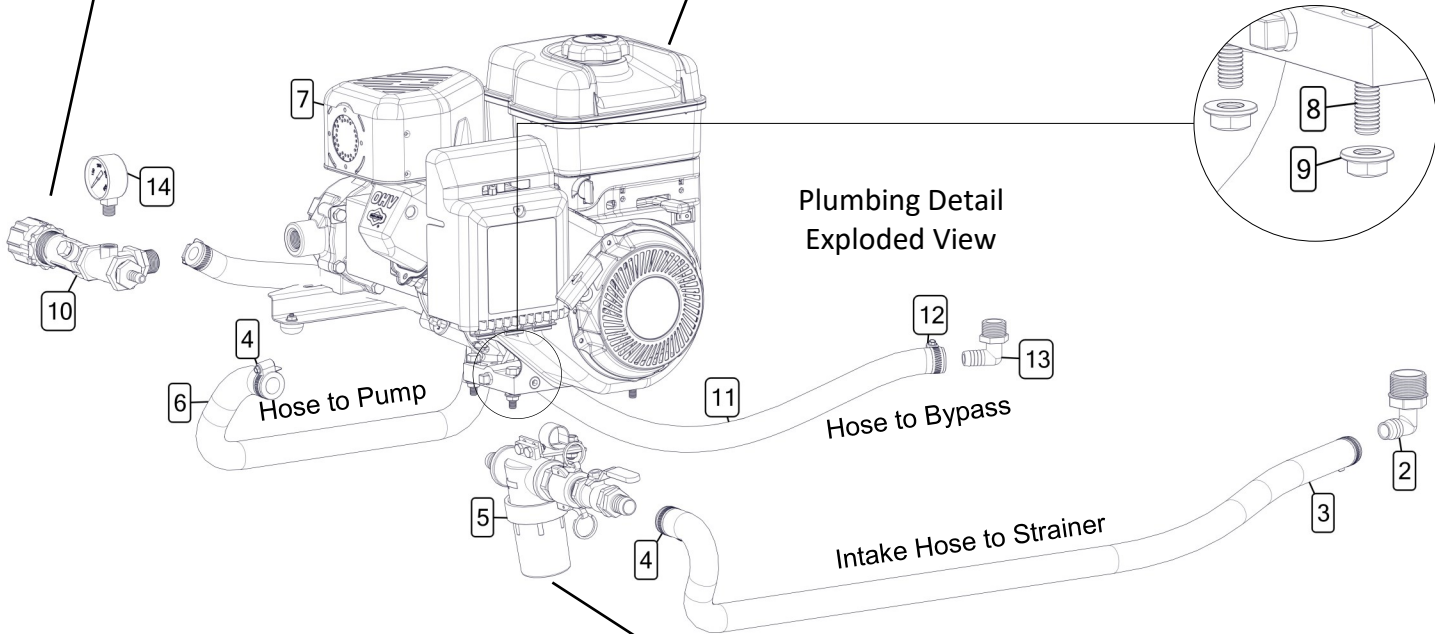

Strainer Detail Exploded View

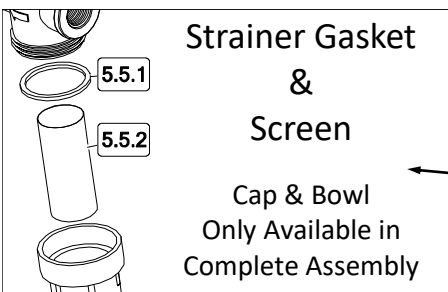
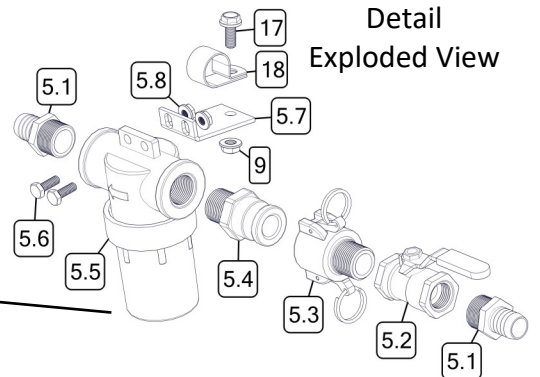

Parts List: SK-110-8R (5301052)

Ref. #	Part #	Description	Qty
1	5169003	110 Gallon Tank (30" Dia.)	1
1.1	63480	8" Tank Lid w/Blue Snap-In Vent	1
1.2	5273736	3/4" Double-Threaded Tank Bulkhead	1
1.3	5274362	1-1/4" Double-Threaded Bulkhead	1
2	5010214	Poly Elbow, 1 1/4" MNPT x 3/4" HB	1
3	5020191	Hose, 3/4"-2 Brd. x 54"	1
4	5051024	Hose Clamp, 3/4"	4
5	5275338	Strainer Assembly (SK-110-8R)	1
5.1	5067127	Poly Fitting, 3/4" MNPT x 3/4" HB	2
5.2	5143190	3/4" "T-800" Brass Ball Valve	1
5.3	5057109	Banjo Female Coupler, 3/4" MNPT	1
5.4	5005158	Banjo Male Adapter, 3/4" MNPT	1
5.5	5116322	3/4" Black Poly Strainer	1
5.5.1	5072229	EPDM Gasket	1
5.5.2	5116323	40 Mesh Screen	1
5.6	5117301	1/4"-20nc x 1" Fling Hex Bolt	2
5.7	5038320-BLK	Strainer Mounting Bracket	1
5.8	5006306	1/4-20 Serrated Fling Hex Nut	2
6	5020076	Hose, 3/4"-2 Brd. x 38"	1
7	5275145	Engine/Pump Sub-Assembly	1
7.1	5067127	3/4" MPT x 3/4" HB Poly Hose Barb	1
7.2	5271509	8-Roller Pump (7560C-R)	1
7.3	5006186	#10-24 Serrated Fling Hex Nut	2
7.4	5023052-BLK	Torque Bracket	1
7.5	5040004	Rubber-Headed Screw Bumper (#10-24)	2
7.6	5005177	Adapter & Kit (Coupler)	1
7.7	5089033	Key, 0.1875 x 0.1875 x 1.375 Long, Raw	1
7.8	5120044-BLK	Shield	1
7.9	5152099	208cc B & S 8.0 Gross Torque w/Gear Reduction	1
7.10	5034634	5/16-18 x 0.625 Fling Hex Bolt	2
8	5034638	5/16-18 x 1.50 Fling Hex Bolt (Full Thread)	4
9	5006307	5/16-18 Serrated Fling Hex Nut	6
10	5275337	Pressure Relief Valve Assembly	1
10.1	5011140	Poly Close Nipple, 3/4" MNPT	1
10.2	5010257	Poly Gauge Tee, 3/4" FNPT	1
10.3	5143199	Pressure Relief Valve, (3/4" NPT)	1
10.4	5067126	Poly Fitting, 3/4" MNPT x 5/8" HB	1
10.5	5067124	Poly Fitting, 3/4" MNPT x 3/8" HB	1
11	5020419	Hose, 5/8"-1 Brd. x 38"	1
12	5051023	Hose Clamp, 5/8"	2
13	5010208	Poly Elbow, 3/4" MNPT x 5/8" HB	1
14	5167005	Gauge, 0-400 PSI (Dry)	1
15	5020099	Hose, 3/8"-2 Brd. x 25 Ft.	1
16	5051144	Hose Clamp, 3/8"	2
17	5117323	5/16-18 x 0.75 Fling Hex Bolt	2
18	5053027	Hose Clip	2
19	5273959	Deluxe Pistol-Grip Handgun w/X-26 Tip	1
19.1	5018331	Brass Handgun Tip (X-26)	1
20	5271863-BLK	Hose Hanger Weldment	2
21	5046085	Cap	2
22	5133101	Nylon Strap (2" x 72")	2
23	5034173	1/4-20 x 3.75 Hook Bolt	4
24	5108041-BLK	Tank Strap Buckle, Bent	4
25	5006259	3/8-16 Serrated Fling Hex Nut	4
26	5273781-RED	110 Gallon Skid Frame	1

Approx. Dimensions:

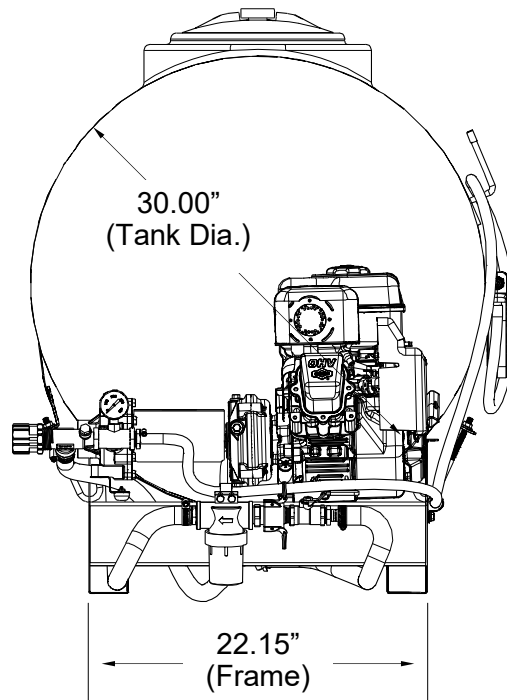
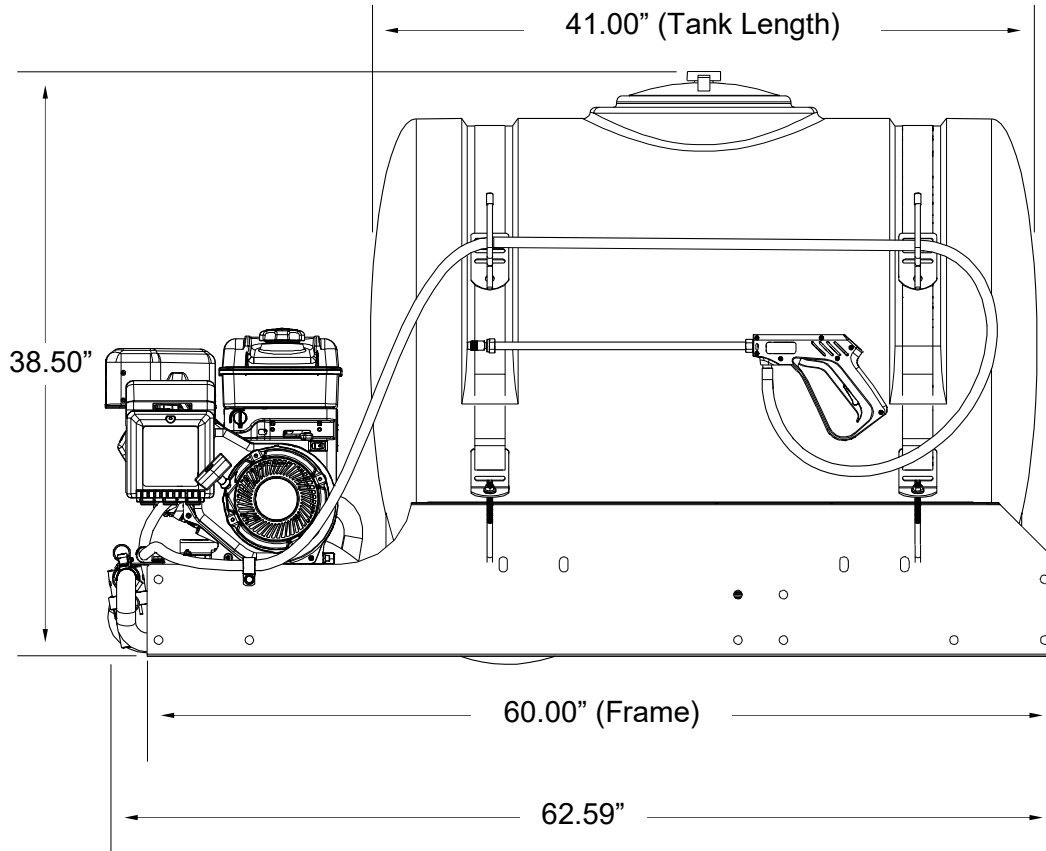

NOTES:

Warranty Info

LIMITED WARRANTY FOR NEW FIMCO, INC.

WHO MAY USE THIS LIMITED WARRANTY. This limited warranty (the "Limited Warranty") is provided by Fimco, Inc. to the original purchaser ("you") of the Equipment (as defined below) from Fimco, Inc. or one of Fimco, Inc.'s authorized dealers. This Limited Warranty does not apply to any subsequent owner or other transferee of the Equipment. THIS LIMITED WARRANTY GIVES YOU SPECIFIC LEGAL RIGHTS, AND YOU MAY ALSO HAVE OTHER RIGHTS WHICH VARY FROM STATE TO STATE.

WHAT THIS LIMITED WARRANTY COVERS AND FOR HOW LONG. Fimco, Inc. warrants that any registered new Equipment will be free from defects in material and workmanship for a period of **one (1) year** (homeowner), **90 days** (commercial user), after delivery of the Equipment to you (the "Warranty Period"). The Warranty Period is not extended if Fimco, Inc. repairs or replaces the Equipment.

WHAT IS NOT COVERED BY THIS LIMITED WARRANTY. This Limited Warranty does not apply to: (1) used Equipment; (2) any Equipment that has been altered, changed, repaired or treated since its delivery to you, other than by Fimco, Inc. or its authorized dealers; (3) damage or depreciation due to normal wear and tear; (4) defects or damage due to failure to follow Fimco, Inc.'s operator's manual, specifications or other written instructions, or improper storage, operation, maintenance, application or installation of parts; (5) defects or damage due to misuse, accident or neglect, "acts of God" or other events beyond Fimco, Inc.'s reasonable control; (6) accessories, attachments, tools or parts that were not manufactured by Fimco, Inc., whether or not sold or operated with the Equipment; or (7) rubber parts, such as tires, hoses and grommets.

HOW TO OBTAIN WARRANTY SERVICE. To obtain warranty service under this Limited Warranty, you must (1) provide written notice to Fimco, Inc. of the defect during the Warranty Period and within **thirty (30) days** after the defect becomes apparent or the repair becomes necessary, at the following address: Fimco, Inc., 1000 Fimco Lane, North Sioux City, SD 57049; and (2) make the Equipment available to Fimco, Inc. or an authorized dealer within a reasonable period of time. For more information about this Limited Warranty, please call: **800-831-0027**

WHAT REMEDIES ARE AVAILABLE UNDER THIS LIMITED WARRANTY. If the conditions set forth above are fulfilled and the Equipment or any part thereof is found to be defective, Fimco, Inc. shall, at its own cost, and at its option, either repair or replace the defective Equipment or part. Fimco, Inc. will pay for shipping and handling fees to return the repaired or replacement Equipment or part to you.

LIMITATION OF IMPLIED WARRANTIES AND OTHER REMEDIES. THE REMEDIES DESCRIBED ABOVE ARE YOUR SOLE AND EXCLUSIVE REMEDIES, AND FIMCO, INC.'S SOLE LIABILITY, FOR ANY BREACH OF THIS LIMITED WARRANTY. TO THE EXTENT APPLICABLE, ANY IMPLIED WARRANTIES, INCLUDING, WITHOUT LIMITATION, THE IMPLIED WARRANTIES OF MERCHANTABILITY AND FITNESS FOR A PARTICULAR PURPOSE, SHALL BE LIMITED IN DURATION TO THE WARRANTY PERIOD, AND THE REMEDIES AVAILABLE FOR BREACH THEREOF SHALL BE LIMITED TO THE REMEDIES AVAILABLE UNDER THIS EXPRESS LIMITED WARRANTY. SOME STATES DO NOT ALLOW LIMITATIONS ON HOW LONG AN IMPLIED WARRANTY LASTS, SO THE ABOVE LIMITATION MAY NOT APPLY TO YOU. IN NO EVENT SHALL FIMCO, INC.'S LIABILITY UNDER THIS LIMITED WARRANTY EXCEED THE ACTUAL AMOUNT PAID BY YOU FOR THE DEFECTIVE EQUIPMENT, NOR SHALL FIMCO, INC. BE LIABLE, UNDER ANY CIRCUMSTANCES, FOR ANY CONSEQUENTIAL, INCIDENTAL, SPECIAL OR PUNITIVE DAMAGES OR LOSSES, WHETHER DIRECT OR INDIRECT. SOME STATES DO NOT ALLOW THE EXCLUSION OR LIMITATION OF INCIDENTAL OR CONSEQUENTIAL DAMAGES, SO THE ABOVE LIMITATION OR EXCLUSION MAY NOT APPLY TO YOU.