

## Quick Start Guide

### MINI BIKE

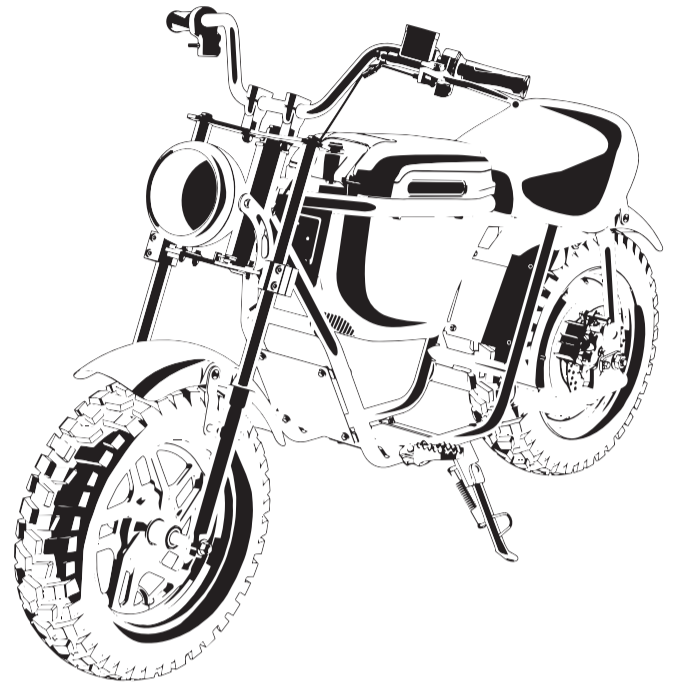

greenworks



Europe



USA



Canada



Rev B

Depending on the model purchased, packaging will contain different accessories and parts. Refer to the package for more details.

## KNOW YOUR PRODUCT

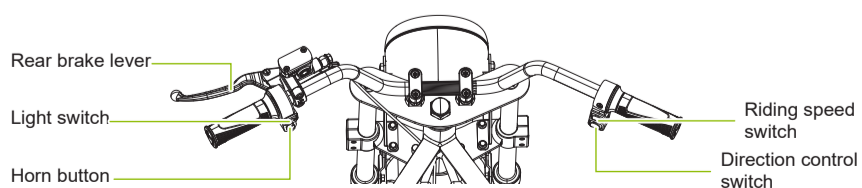
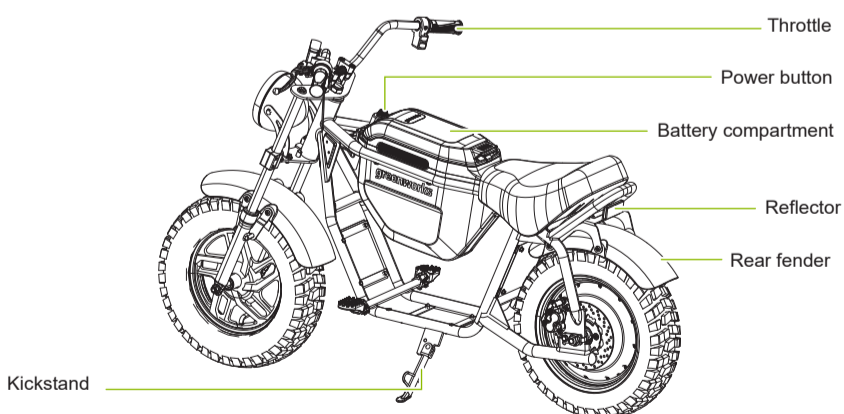
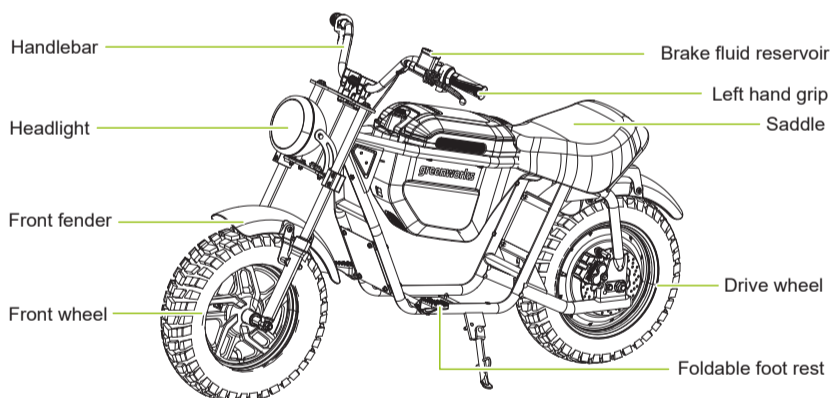

1

## ASSEMBLY

Attach the handlebars

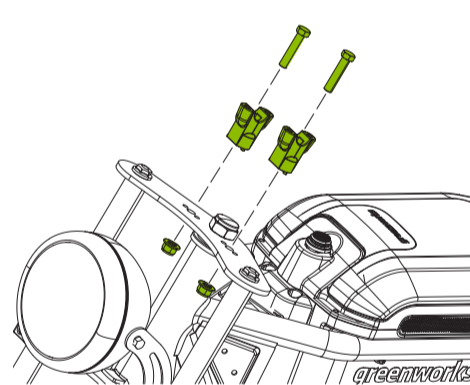

2

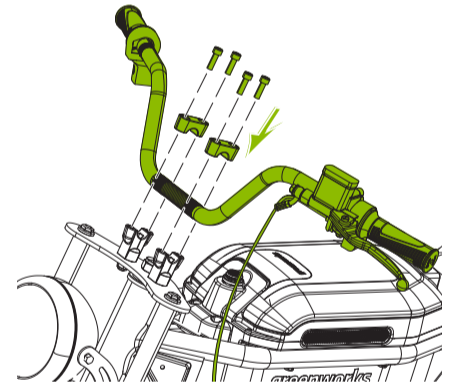

3

4

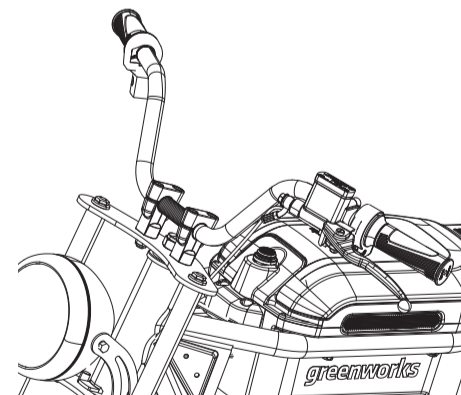

Inflate the tires

5

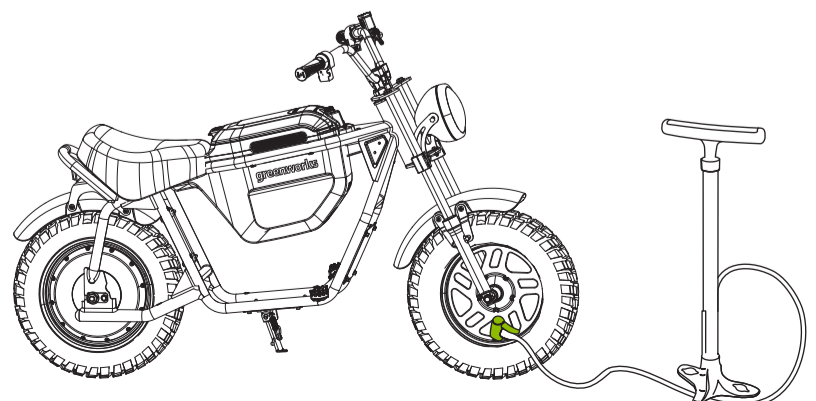

# Operation

## Connect the battery to the product

6

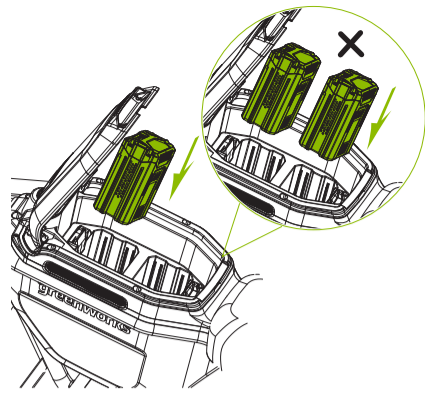
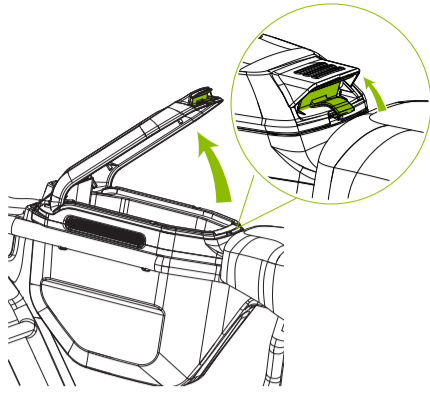

Only one battery can be installed and it must be placed in the first battery holder.

10

7

## Start the product

8

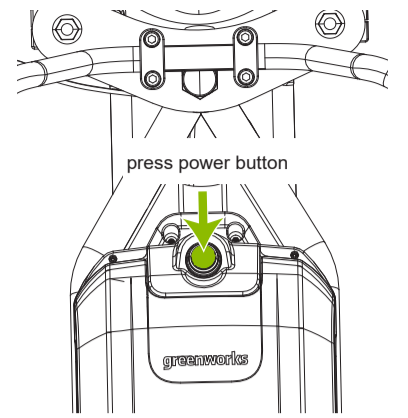
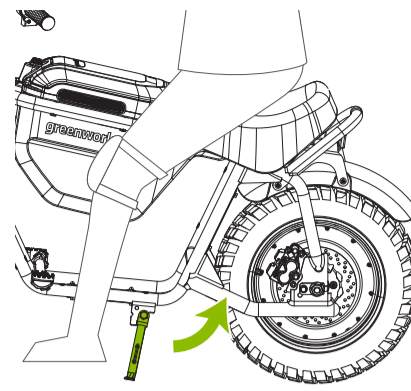

11

9

pull brake

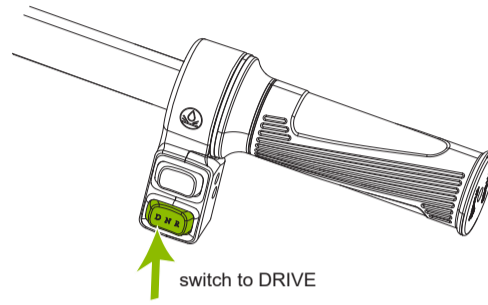
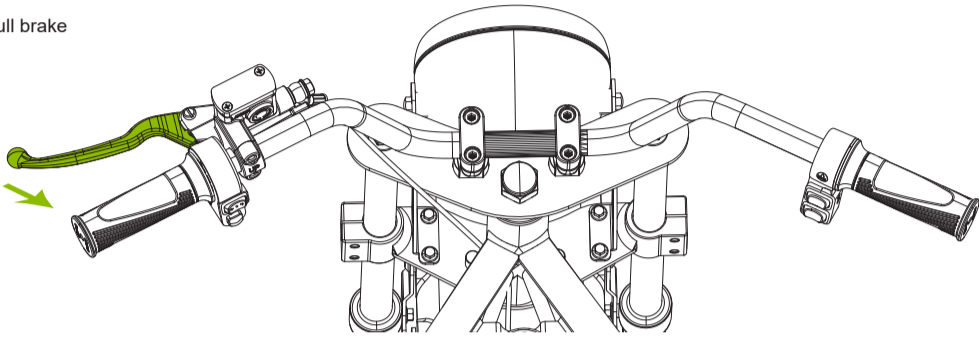

switch to DRIVE

Switch Position	Riding Direction
D (DRIVE)	Forward
N (NEUTRAL)	Park
R (REVERSE)	Reverse

12

13

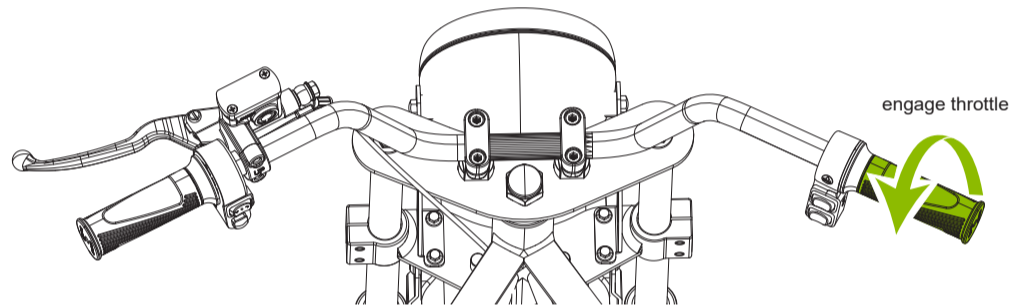

engage throttle

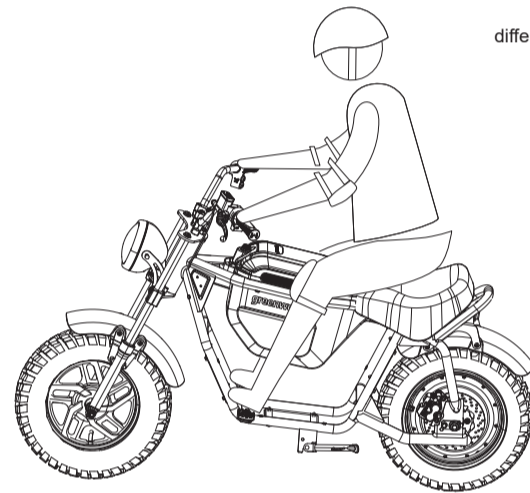

different helmet/ different figure

## Adjust the riding speed

14

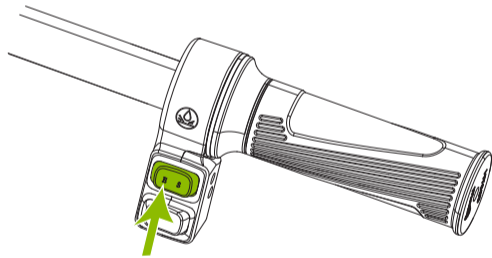

Switch Position	Riding Speed
E (ECO)	Slow
S (SPORT)	Fast

## Adjust the headlight

15

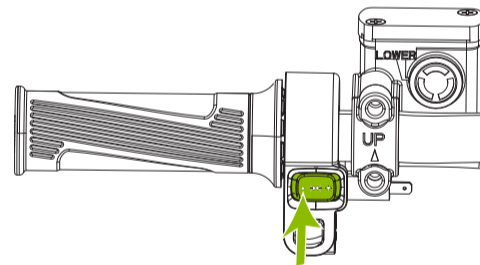

Switch position	Headlight condition
○	Turn off the light
☽	Low beam light
☀	High beam light

## Stop the product

16

release throttle and engage hand brake

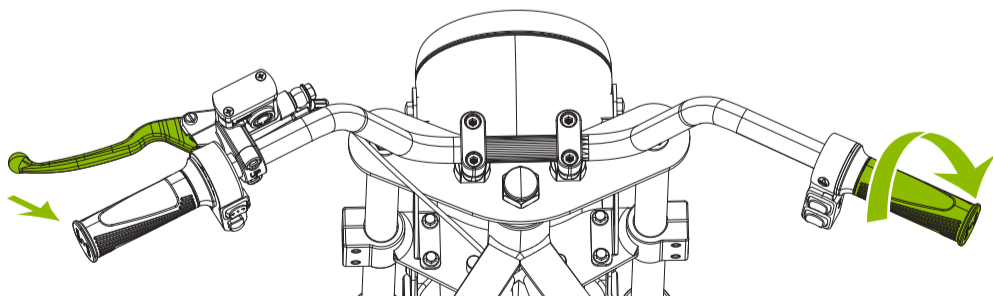

17

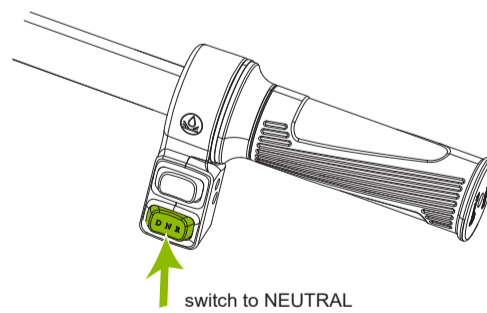

switch to NEUTRAL

18

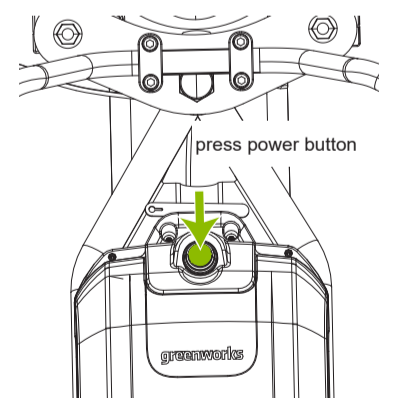

19

## Remove the battery

20

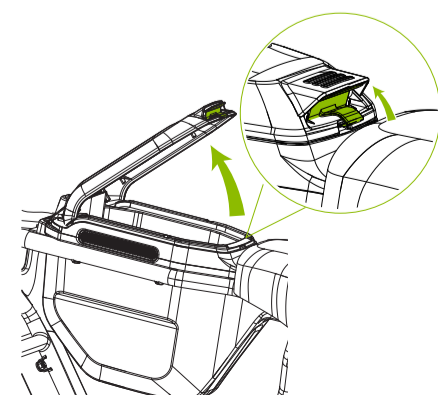
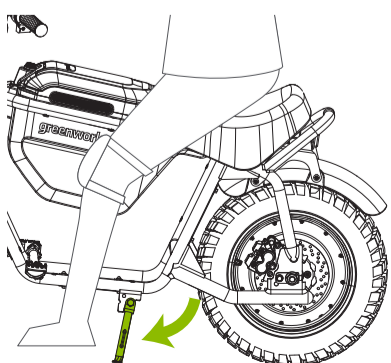

21

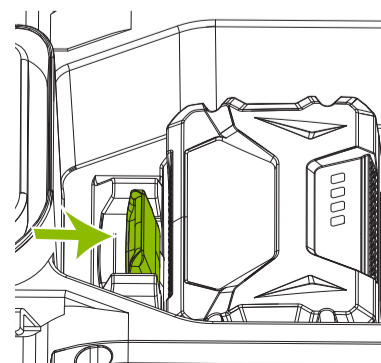

22

