

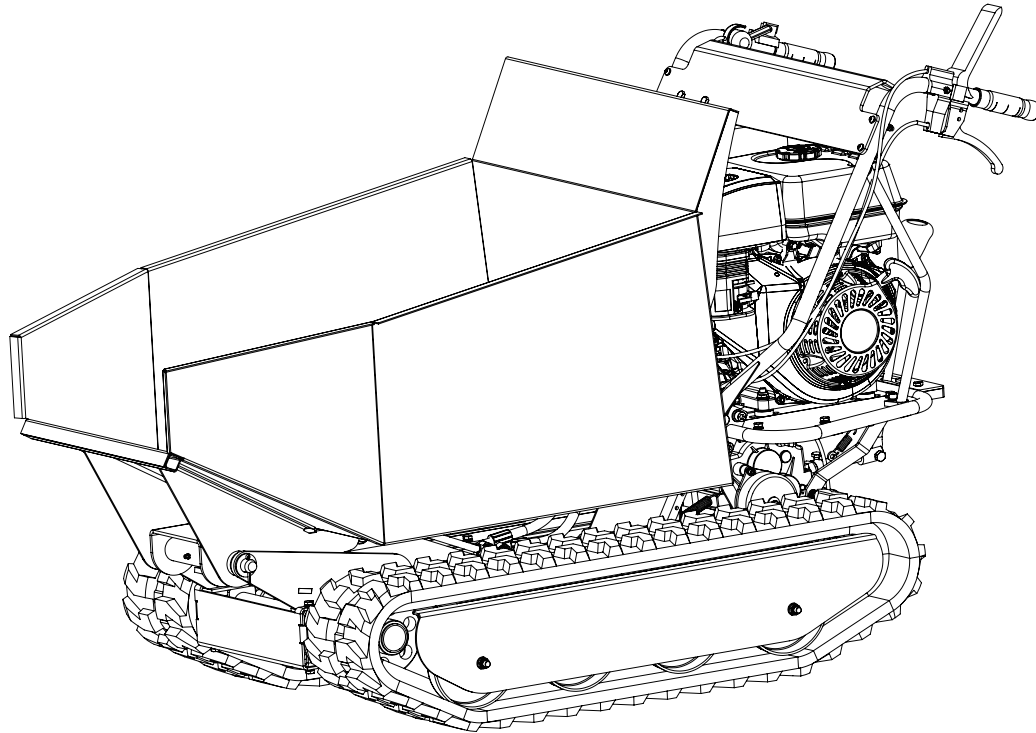

SCAN THE QR CODE OR VISIT [DETAILK2.COM](http://DETAILK2.COM) TO VIEW OR DOWNLOAD THE USER MANUAL.

SCANNEZ LE CODE QR OU VISITEZ [DETAILK2.COM](http://DETAILK2.COM) POUR CONSULTER OU TÉLÉCHARGER LE MANUEL D'UTILISATION.



# MINI TRACK DUMP CART

## Operator's Manual

**MODEL NUMBER : OPD814**

**SERIAL NUMBER :**

Both model number and serial number may be found on the main label.  
You should record both of them in a safe place for future use.

## FOR YOUR SAFETY

**READ AND UNDERSTAND THE ENTIRE MANUAL BEFORE  
OPERATING MACHINE**

[www.detailk2.com](http://www.detailk2.com)

# WARRANTY

---

**PLEASE DO NOT RETURN TO THE STORE**

**YOU HAVE A 1-YEAR WARRANTY AND DK2 WILL REPLACE A DEFECTIVE PART FOR FREE. CALL US AT 1 (888) 277-6960 FOR FAST WARRANTY PARTS AND QUESTIONS.**

## **WHAT IS COVERED – 3-YEAR ENGINE AND 1-YEAR DK2 LIMITED WARRANTY INCLUDED**

DK2 warrants to the original purchaser that product will be free and clear of manufacturing defects in workmanship and materials under normal use and service for a period of one (1) year from the date of the original purchase. If within one (1) year from the original date of purchase this product fails due to defect in material or workmanship, DK2 will repair, replace, or supply any covered defective part at our option. DK2 POWER is 1-year parts only warranty no labor. KOHLER® 3-year warranty is PARTS and LABOR.

Upon expiry of one (1) year, DK2 will have no further liability related to the product. DK2 does not authorize any party, including its authorized distributors or dealers, to offer any other warranty on behalf of DK2.

## **SERIAL NUMBERS MUST BE REGISTERED ONLINE AT [WWW.DK2.COM](http://WWW.DK2.COM), WARRANTY NON-TRANSFERABLE.**

KOHLER® ENGINES –KOHLER® CH SERIES ENGINES 3 YR PARTS AND LABOR WARRANTY

KOHLER® ENGINES –KOHLER® SH SERIES ENGINES RESIDENTIAL 2 YR PARTS AND LABOR WARRANTY

See your KOHLER® manual for specific warranty.

DK2 – 1-year parts only, no labor. 3-year KOHLER® warranty.

## **THIS WARRANTY DOES NOT COVER OR APPLY TO:**

- (a) Damage to the product due to misuse, mishandling and abuse
- (b) Improper installation, maintenance and storage
- (c) Expendable parts such as nuts and bolts, pins and springs, wiring and switch components, hydraulic hoses and fittings, cutting teeth, cutting chains, cutting blades, throttles, belts and tires.
- (d) Normal wear and tear
- (e) Consequential damage & incidental damages such as damage to persons or property

## **PROCEDURE FOR OUTDOOR POWER EQUIPMENT WARRANTY**

Within the one (1) year warranty period, the purchaser of the product can CALL **1 (888) 277-6960** or contact us on **[www.DK2.com](http://www.DK2.com)**. Notify us of the claimed defect and provide proof of original purchase. At this time the validity of the claim will be determined, and if approved replacement parts will be issued. No returned product will be accepted under warranty unless accompanied by an RGA# issued by DK2.

## **DAMAGED FREIGHT**

Damage to your product caused by freight mishandling is NOT covered under warranty. If your freight arrives damaged, REFUSE it. **Inspect your product when it arrives**, otherwise if you accept it, you will be responsible for filing any freight claims with the delivery company. DK2 warranty excludes damage to product.

## **RETURNS BEFORE GAS AND OIL**

Follow the return policy from the retailer you purchased the equipment from.

## **RESOLUTION FOR A DEFECTIVE PRODUCT AFTER GAS AND OIL HAS BEEN ADDED.**

Call us at 1 (888) 277-6960 between 8am-4pm Monday to Friday EST.



**DO NOT RETURN THIS  
PRODUCT TO THE STORE WITH  
GAS AND OIL IN IT.**

**If you have assembly or other product questions,  
please contact our technical customer service team by  
email or phone for assistance.**



1 (888) 277-6960



support@detailk2.com



detailk2.com/contact-us

## TABLE OF CONTENTS

<b>Introduction</b>	<b>2</b>
Specifications	2
<b>Symbols</b>	<b>3</b>
<b>Safety</b>	<b>4</b>
General Safety Rules	4
Specific Safety Rules	6
<b>Unpacking The Container</b>	<b>7</b>
<b>Contents Supplied</b>	<b>8</b>
<b>Assembly</b>	<b>8</b>
<b>Know your Machine</b>	<b>8</b>
Features & Controls	8
Operation	10
<b>Maintenance</b>	<b>12</b>
<b>Storage</b>	<b>18</b>
<b>Trouble Shooting</b>	<b>19</b>
<b>Parts Diagram</b>	<b>20</b>
<b>Parts Lists</b>	<b>21</b>

## INTRODUCTION

Your new dump cart will more than satisfy your expectations. It has been manufactured under stringent quality standards to meet superior performance criteria. You will find it easy and safe to operate, and with proper care, it will give you many years of dependable service.



**Carefully read through this entire operator's manual before using this unit. Take special care to heed the cautions and warnings.**

The four-speed gearbox, three forward and one reverse, lies at the heart of the unit. It is oversized so as to manage safely the huge torques generated by the engine. Thanks to its efficient reduction gearing, it is capable of moving around in every situation and bearing any load.

The **Engine manufacturer** is responsible for all engine-related issues with regards to performance, power rating, specifications, warranty and service. Please refer to the **Engine Manufacturer's** owner's/operator's manual, packed separately with your unit, for more information.

## Specification

<b>Item No.</b>	<b>OPD814</b>
<b>Engine</b>	<b>KOHLER CH395</b>
<b>Net Power</b>	<b>9.5hp (7.1kw)</b>
<b>Transmission</b>	<b>3F+1R</b>
<b>Load Capacity</b>	<b>1100 lb</b>
<b>Box Length</b>	<b>37.4 in</b>
<b>Box Width</b>	<b>26.7 in</b>
<b>Box Depth</b>	<b>18.3 in</b>
<b>Track Width</b>	<b>7.0 in</b>
<b>Sound power level</b>	<b>107 dB(A) <math>k=2</math> dB(A)</b>
<b>Sound pressure level</b>	<b>82.2 dB(A) <math>k=2</math> dB(A)</b>
<b>Weight</b>	<b>613 lb</b>
<b>Pump Flow</b>	<b>2.4 GPM</b>

## ENVIRONMENTAL



Recycle unwanted materials instead of disposing of them as waste. All tools, hoses and packaging should be resorted, taken to the local recycling center and disposed of in an environment-friendly safe way.

## SYMBOLS

The rating plate on your machine may show symbols. These represent important information about the product or instructions on its use.



Read these instructions carefully.



Wear eye protection.  
Wear hearing protection.



Wear protective gloves.



Wear safety footwear.



Do not remove or tamper with the protection and safety devices.



No smoking, sparks, or flames



Do not touch parts that are hot from operation. Serious burns may result.



Keep your hands clear from all rotating parts.



Never start or run the engine inside a closed area.



Do not operate on slopes with angle over 20° or tip loading at an inclined position.



Be aware, objects may be thrown while in use.



The exhaust fumes are dangerous, containing carbon monoxide. Staying in the environment can lead to unconsciousness and death.



Always turn off the engine before starting maintenance.



Keep children and bystanders off and away.

GB

# SAFETY

## General Safety Rules

### Understand Your Machine

Read this manual and labels affixed to the machine to understand its limitations and potential hazards.

Be thoroughly familiar with the controls and their proper operation. Know how to stop the machine and disengage the controls quickly.

Make sure to read and understand all the instructions and safety precautions as outlined in the Engine Manufacturer's manual packed separately with your unit. Do not attempt to operate the machine until you fully understand how to properly operate and maintain the engine and know how to avoid accidental injuries and/or property damage.

If the unit is to be used by someone other than original purchaser, or is to be loaned, rented, or sold, always provide this manual and any needed safety training before operation. The user can prevent and is responsible for accidents or injuries that may occur to themselves, to other people, or to property.

Do not force the machine beyond its limits. Use the correct machine for your application.

### Personal Safety

Do not permit children to operate this machine at any time.

Keep children, pets, and other people not using the unit away from the work area. Be alert and shut off the unit if anyone enters work area. Keep children under the watchful care of a responsible adult.

Do not operate the machine while under the influence of drugs, alcohol, or any medication that could affect your ability to use it properly.

Dress properly: Wear long, heavy pants, work boots, and work gloves. Do not wear loose clothing, short pants, or jewelry of any kind. Secure long hair so it is above shoulder level. Keep your hair, clothing, and gloves away from moving parts. Loose clothes, jewelry, or long hair can be caught in moving parts.

Protect eyes, face, and head from objects that may be thrown from the unit. Always wear safety goggles or safety glasses with side shields when operating.

Wear appropriate hearing protection.

Always keep hands and feet away from all moving parts during operation. Moving parts can cut or crush body parts.

Always keep hands and feet away from all pinch points.

Do not touch parts that might be hot from operation. Allow parts to cool before attempting to maintain, adjust, or service.

Stay alert, watch what you are doing, and use common sense when operating the machine.

Do not overreach. Do not operate the machine while barefoot or when wearing sandals or similar lightweight footwear. Wear protective footwear that will protect your feet and improve your footing on slippery surfaces. Keep proper footing and balance at all times. This enables better control of the machine in unexpected situations.

### Inspect Your Machine

Check your machine before starting it. Keep guards in place and in working order. Make sure all nuts, bolts, etc., are securely tightened.

Never operate the machine when it is in need of repair or is in poor mechanical condition. Replace damaged, missing, or failed parts before using it. Check for fuel leaks. Keep the machine in safe working condition.

Do not use the machine if the engine's switch does not turn off the engine when running. Any gasoline powered machine that can't be controlled with the engine switch is dangerous and must be replaced.

Regularly check to see that keys and adjusting wrenches are removed from the machine area before starting it. A wrench or a key that is left attached to a rotating part of the machine may result in personal injury.

Avoid accidental starting. Be sure the engine's switch is off before transporting the machine or performing any maintenance or service

on the unit. Transporting or performing maintenance or service on a machine with its switch on invites accidents.

If the machine should start to vibrate abnormally, stop the engine (motor) and check immediately for the cause. Vibration is generally a warning sign of trouble.

### Engine Safety

This machine is equipped with an internal combustion engine. Do not use on, or near, forest-covered or brush-covered land unless the exhaust system is equipped with a spark arrester meeting applicable local, state, or federal laws.

In the state of California, a spark arrester is required by law. Other states have similar laws. A spark arrester, if used, must be maintained in effective working order by the operator.

Never start or run the engine inside a closed area. The exhaust fumes are dangerous, containing carbon monoxide, an odorless and deadly gas. Operate this unit only in a well-ventilated outdoor area.

Do not tamper with the engine in an effort to get it to run at higher speeds. The maximum engine speed is preset by the manufacturer and is within safety limits. See engine manual.

Keep a Class B fire extinguisher on hand when operating this machine in dry areas as a precautionary measure.

### Fuel Safety

Fuel is highly flammable, and its vapors can explode if ignited. Take precautions when using to reduce the chance of serious personal injury.

When refilling or draining the fuel tank, use an approved fuel storage container while in a clean, well-ventilated outdoor area. While adding fuel or operating the unit, do not smoke, and stay away from sparks, open flames, or other sources of ignition near the area of operation. Never fill the fuel tank indoors.

To avoid sparking or arcing, keep grounded conductive objects – such as tools – away from exposed, live electrical parts and connections. These events could ignite fumes or vapors.

Always stop the engine and allow it to cool before filling the fuel tank. Never remove the cap of the fuel tank or add fuel while the engine is running or when the engine is hot. Do not operate the machine with known leaks in the fuel system.

Loosen the fuel tank cap slowly to relieve any pressure in the tank.

Never overfill the fuel tank. Because engine heat can cause fuel to expand, never fill the tank to more than 1/2" below the bottom of the filler neck. This will provide space for fuel expansion.

Replace all fuel tank and container caps securely and wipe up spilled fuel. Never operate the unit without the fuel cap securely in place.

Avoid creating a source of ignition for spilled fuel. If fuel is spilled, do not attempt to start the engine. Instead, move the machine away from the area of spillage and avoid creating any source of ignition until fuel vapors have dissipated.

When fuel is spilled on yourself or your clothes, wash your skin and change clothes immediately.

Store fuel in containers specifically designed and approved for fuel storage.

Store fuel in a cool, well-ventilated area, safely away from sparks, open flames, or other sources of ignition.

Never store fuel – or a machine with fuel in the tank – inside a building where fumes may reach a spark, open flame, or any other source of ignition (such as a water heater, furnace, or clothes dryer). Allow the engine to cool before storing in any enclosure.

## Specific Safety Rules

Thoroughly inspect the area to be worked. Keep the working area clean and free of debris to prevent tripping. Operate on flat, level ground.

Never place any part of your body where it would be in danger if movement should occur during assembly, installation, operation, maintenance, repair, or relocation.

Keep all bystanders, children, and pets at least 905in away. If you are approached, stop the unit immediately.

Do not mount anything on the hopper and never carry passengers.

Never park the machine in a place with unstable ground that could give way, particularly when it is full.

Disengage clutch lever before starting the engine.

Start the engine carefully according to instructions and with feet away from the moving parts.

Never leave the operating position when the engine is running.

Always hold the unit with both hands when operating. Keep a firm grip on the handlebars. Be aware that the machine may unexpectedly bounce upward or jump forward if the machine should strike buried obstacles such as large rocks or roots.

Walk, never run with the machine.

**Do not overload the machine capacity. Always drive at a safe speed, and adjust the speed to the slope of the land, the surface conditions of the road, and the weight of the load.**

Use extreme caution when in reverse or pulling the machine towards you.

Exercise extreme caution when operating on or crossing gravel drives, walks, or roads. Stay alert for hidden hazards or traffic.

On soft ground, drive at the first forward/reverse gear. Do not rapidly accelerate, turn sharply or stop.

Pay the utmost attention when working on frozen ground, as the machine may tend to skid.

Do not operate the machine in confined areas where there may be a risk of crushing the operator between the machine and another object.

Never operate the machine on slopes where angle is over 20°.

When operating on a slope, whether moving forward or in reverse, always make certain that the weight is evenly balanced. Always operate the machine straight up or down slopes, never drive sideways or across the slope. Do not shift gears on slopes.

When dumping the contents of the hopper, the center of gravity will change continuously and the ground conditions will be essential for the stability of the machine. Use extra caution and control when dumping the hopper on unstable ground, such as wet clay or soil.

# UNPACKING THE CONTAINER

GB

Use the screwdriver and hammer to open all the side locks.

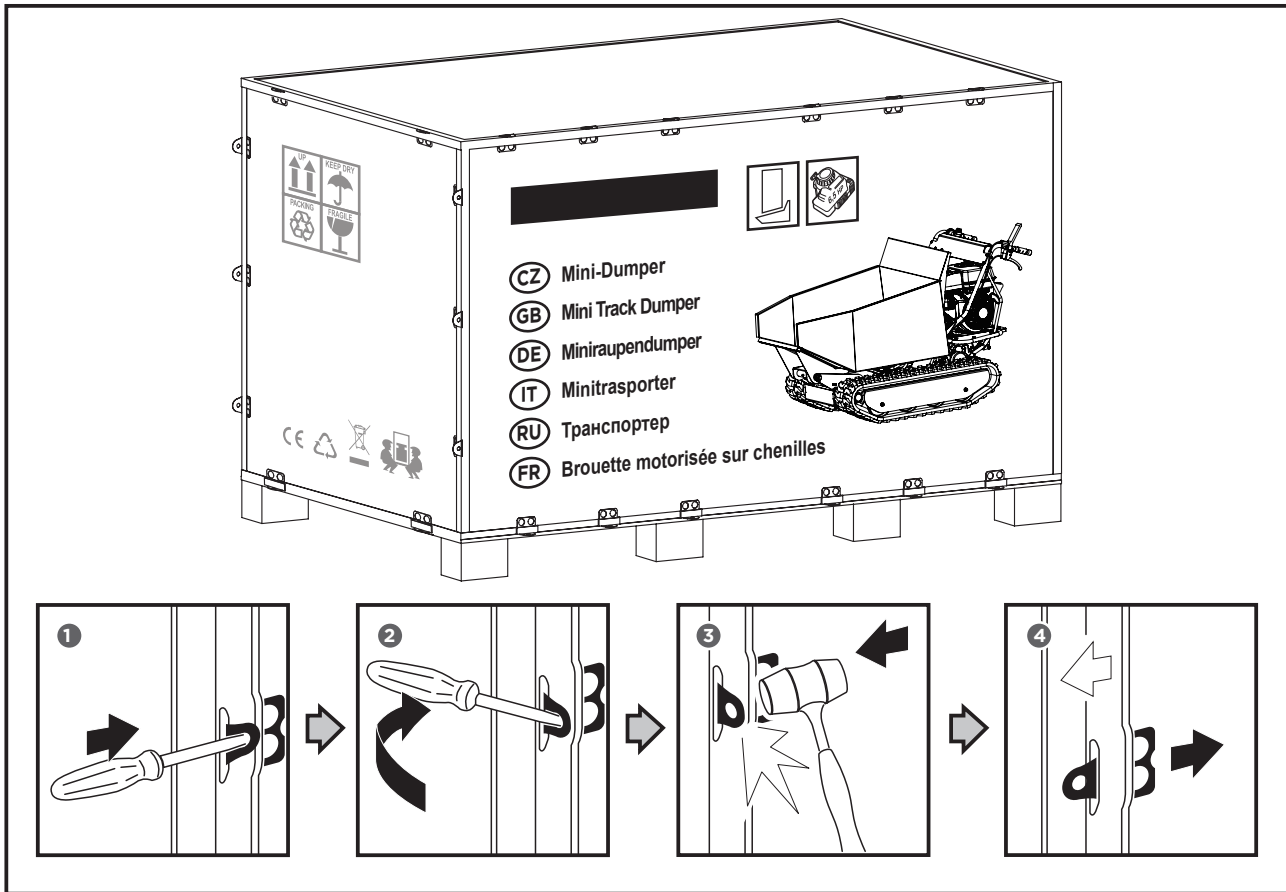

Remove all the plywood plates, and remove all the loose parts on the bottom pallets.

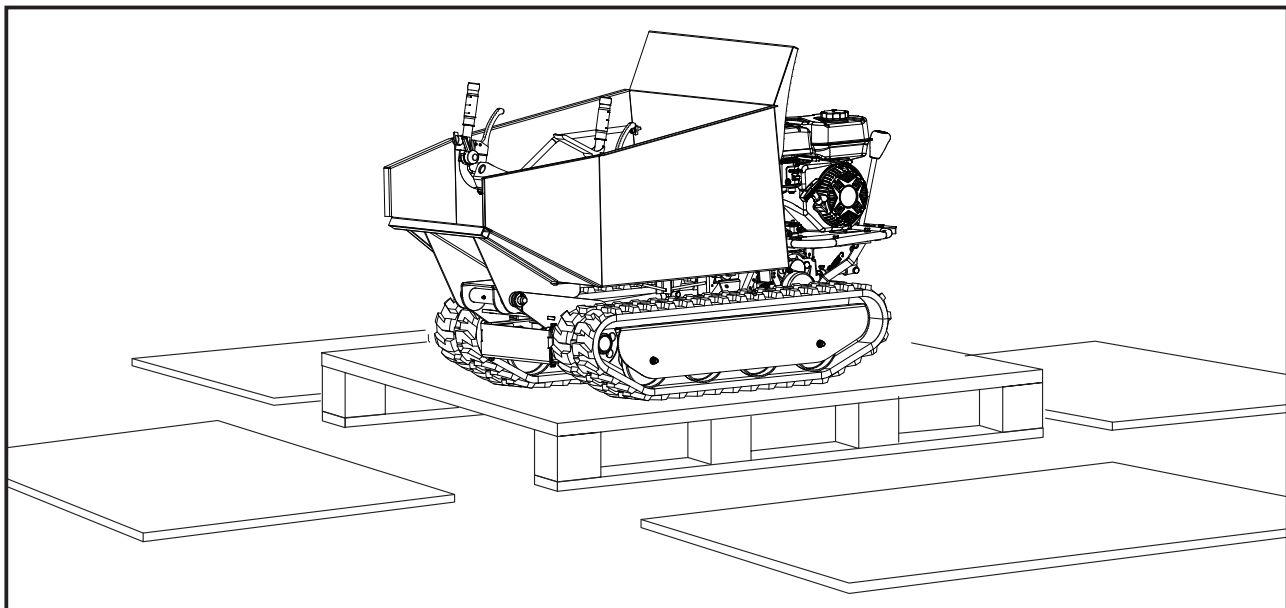

## CONTENTS SUPPLIED

The dump cart comes partially assembled and is shipped in carefully packed package. After all the parts have been removed from the package, you should have:

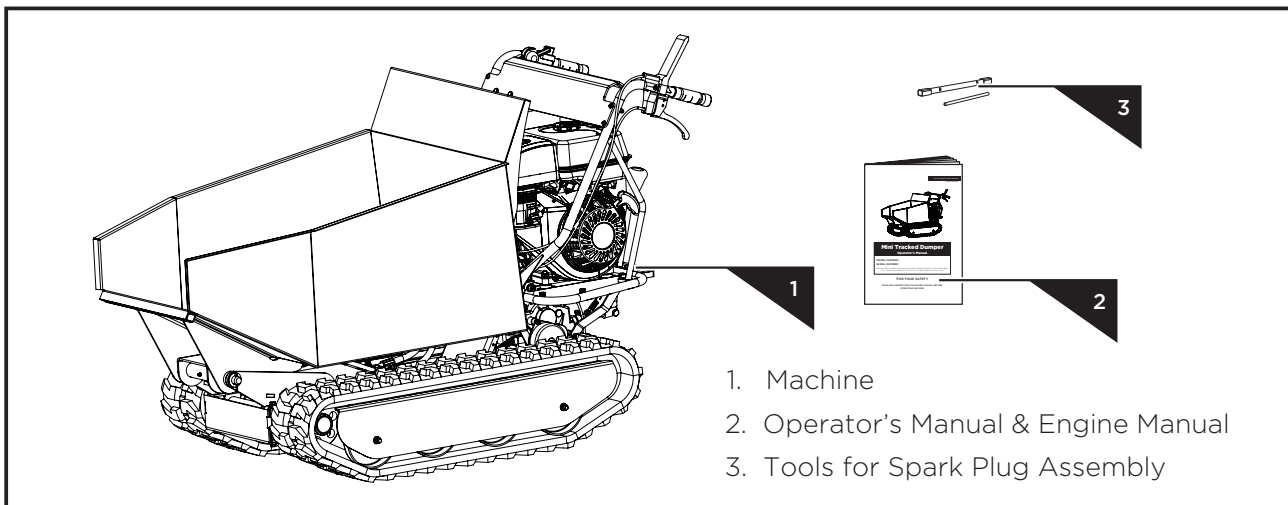

## KNOW YOUR MACHINE

### Features and Controls

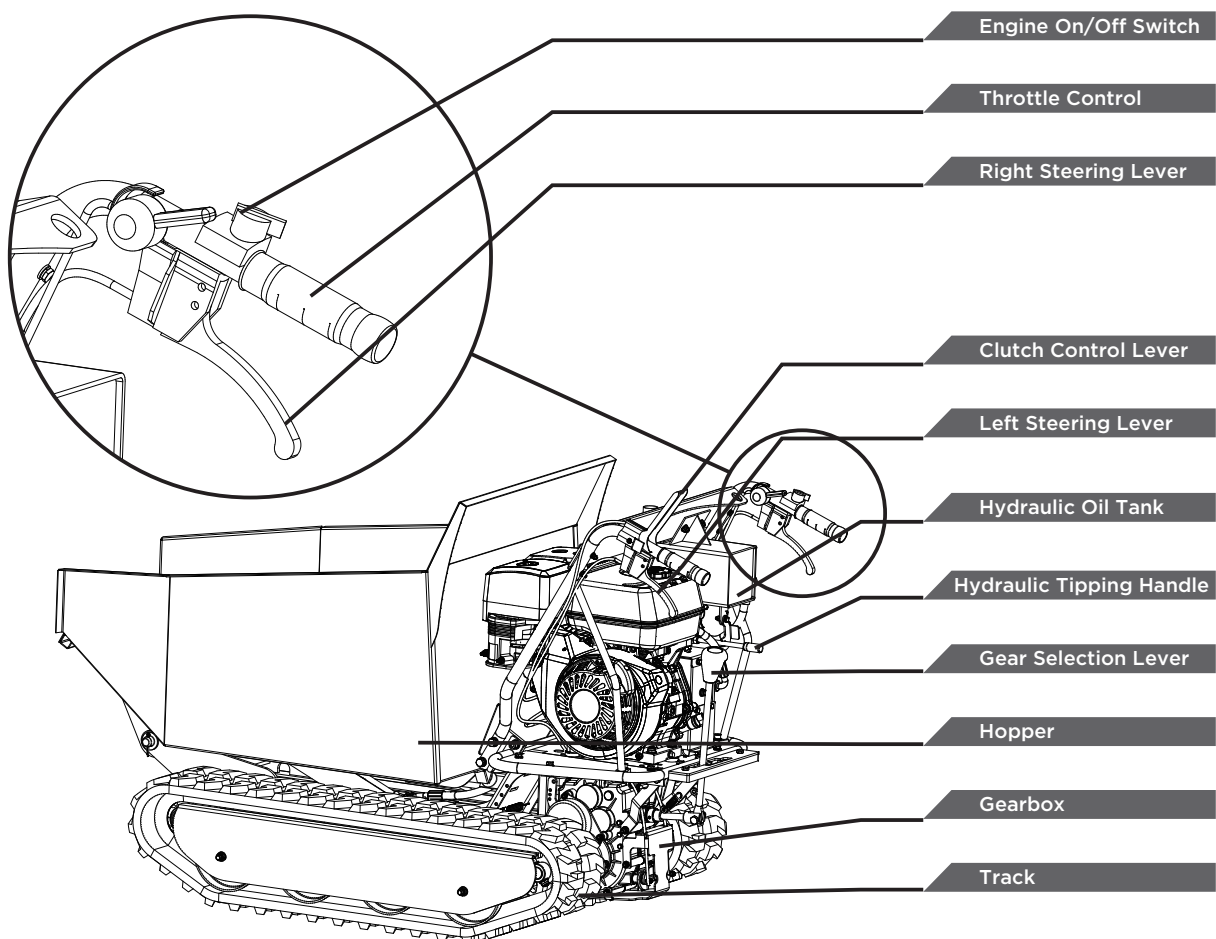

### Gear Selection Lever

The gear selection lever has 4 positions: 3 forward speeds and 1 reverse. To change speeds, move the speed shift lever to the desired position. The lever locks in a notch at each speed selection.



**Always release the clutch control lever before changing speeds. Failure to do so will result in damage to the power trackbarrow.**

Slower speeds are for heavier loads, while faster speeds are for transporting light loads or an empty hopper. It is recommended that you use a slower speed until you are familiar with the operation of the dump cart.

If the engine slows down under a load or the tracks slip, shift the machine into a lower gear.

If the front of the machine rides up, shift the machine into a lower gear. If the front continues to ride up, lift up on the handles.

### Left/Right Steering Lever

Operate the lever to turn left/right.



**Operate the steering levers only at a reduced speed.**

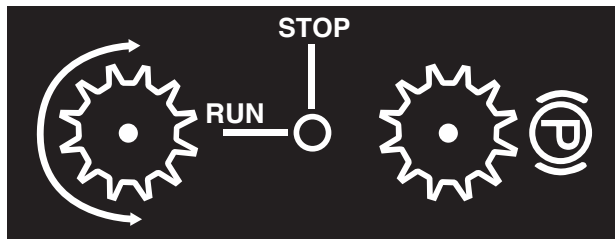

### Hydraulic Tipping Handle

Using your left hand pull the locking plate up to release the tipping handle, and hold in position.

To raise the hopper, pull the tipping handle upwards until the hopper has reached the desired position. To stop raising the hopper, simply release the tipping handle and return the locking plate to its original position.

To lower the hopper, first pull the locking plate up with your left hand to release the tipping handle, and then pull the tipping handle down with the right hand. When the hopper is lowered to the original position, release the tipping handle back to its original position and lock securely with the locking plate.

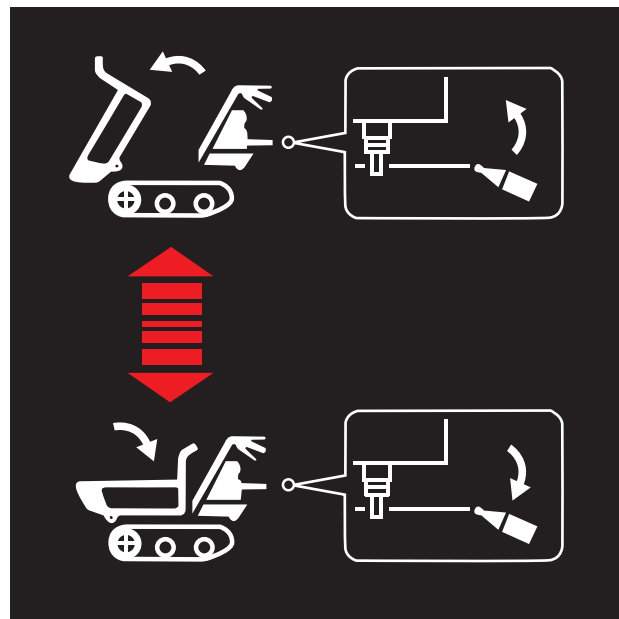
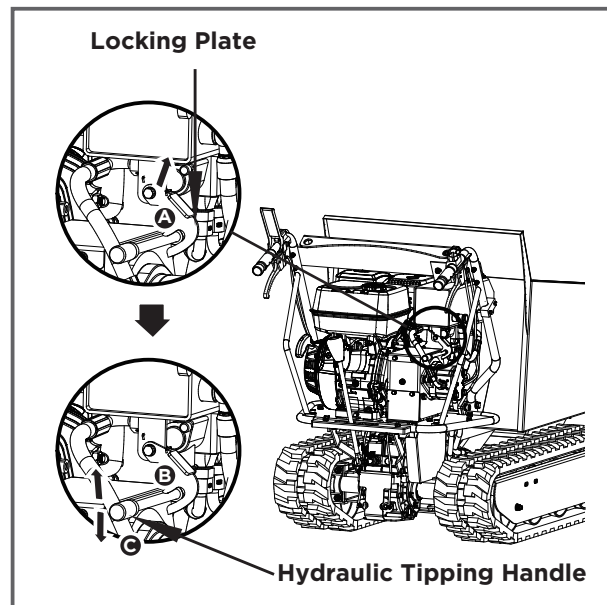

### Gas Spring Assistance

The gas spring assistance provides support when lifting and lowering the hopper.

### Engine On/Off Switch

The engine switch has two positions. OFF - engine will not start or run. ON - engine will start and run.

### Recoil Starter Handle

The recoil starter handle is used to start the engine.

### Fuel Shut-Off Valve

The fuel shut-off has two positions:

CLOSED (  ) - Use this position to service, transport, or to store the unit.



OPEN (  ) - Use this position to run the unit.

### Throttle Control

The throttle control regulates the speed of the engine, and moves between FAST , SLOW , and STOP positions.

The throttle control will shut off the engine when it is moved to the STOP position.

### Choke Control

The choke control is used to choke the carburetor and assist in starting the engine. The choke control slides between the CHOKE CLOSED  and CHOKE OPEN  positions.



**Never use choke to stop engine.**

### Clutch Control Lever

Squeeze the control lever, clutch engaged. Release the lever, clutch disengaged.

## Operation

### Add Oil To Engine



**No oil in the engine originally, but a bottle of engine oil is in scope of delivery. Don't start the engine before adding oil.**

1. Make sure the dump cart is on a flat, level surface.
2. Remove the oil fill cap/dipstick to add oil.

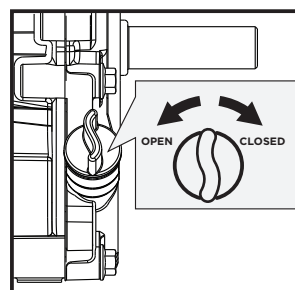

3. Using a funnel, add oil up to the FULL mark on the dipstick. (See engine manual for oil capacity, oil recommendation, and location of fill cap.)



**DO NOT OVERFILL. Check engine oil level daily and add as needed.**

### Add Gasoline To Engine



**Gasoline is highly flammable and explosive. You can be burned or seriously injured when handling fuel. Use extreme care when handling gasoline.**



**Fill the fuel tank outdoors, never indoors. Gasoline vapors can ignite if they collect inside an enclosure. Explosion can result.**

1. The engine must be off and allowed to cool at least two minutes before adding fuel.
2. Remove the fuel filler cap and fill the tank. (See engine manual for fuel capacity, fuel recommendation, and location of fuel cap.)



**IMPORTANT: DO NOT OVERFILL!**

This equipment and/or its engine may include evaporative emissions control system components, required to meet EPA and/or CARB regulations, that will only function properly when the fuel tank has been filled to the recommended level. Overfilling may cause permanent damage to evaporative emissions control system components. Filling to the recommended level ensures a vapor gap required to allow for fuel expansion. Pay close attention while filling the fuel tank to ensure that the recommended fuel level inside the tank is not exceeded. Use a portable gasoline container with an appropriately sized dispensing spout when filling the tank. Do not use a funnel or other device that obstructs the view of the tank filling process.

3. Reinstall the fuel cap and tighten. Always clean up spilled fuel.

**Starting Engine**

1. Move the engine switch to the ON position.

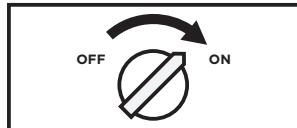

2. Open the fuel shut-off valve.

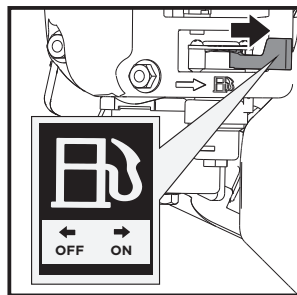

3. Move the choke lever to the CLOSED position.

If the engine is hot, closing the choke is not necessary.

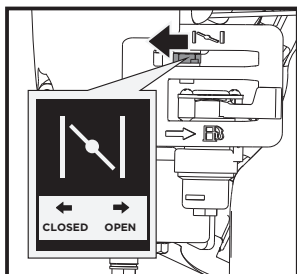

4. Move the throttle lever slightly to the FAST speed.

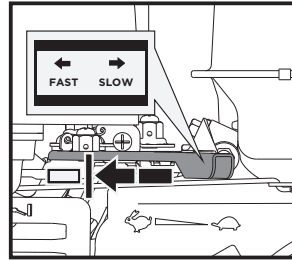

5. Pull the recoil starter until the engine starts. Return the recoil to the home position after each pull. Repeat the steps as needed. Once engine has started, set the throttle to the FAST position before you operate the unit.



**Rapid retraction of the starter cord (kickback) will pull your hand and arm toward the engine faster than you can let go. Broken bones, fractures, bruises, or sprains could result.**

**Operating**

After the engine warms up, move the throttle lever to accelerate engine speed.

Engage the required gear and slowly squeeze the clutch control lever. If the gear does not engage immediately, slowly release the clutch lever and try again. In this way the dump cart will start moving.

The dump cart has the steering levers on the handlebars, which makes steering very easy. To turn right or left, simply pull the corresponding right or left steering lever.

The sensitivity of the steering increases in proportion to the speed of the machine and the load. With an empty machine, a light pressure on the lever is all that is needed to turn. When the machine is fully loaded, more pressure is required.

The dump cart has a maximum capacity of 1100 LBS. However, it is advisable to assess the load and adjust it according to the ground on which the machine will be used.

It is therefore advisable to cover such stretches using low gear and taking extra care. In such situations, the machine should be kept in low gear for the whole stretch.

Avoid sharp turns and frequent changes of direction while driving on rough, hard terrains full of sharp, uneven points with a high degree of friction.

Even though the unit has rubber tracks, remember to be careful when working in adverse weather conditions (ice, heavy rain and snow) or on types of ground that could make the dump cart unstable.

Please note that as this is a track vehicle, it is subject to a considerable pitching movement when passing over bumps, holes and steps.

When the clutch control lever is released, the machine will stop and brake automatically.



If the machine is stopped on a steep slope, a wedge should be placed against one of the tracks.

### Idle Speed

Set the throttle control lever to the SLOW position to reduce stress on the engine when work is not being performed. Lowering the engine speed will help extend the life of the engine, as well as conserve fuel and reduce noise level.

### STOP ENGINE

To stop the engine in an emergency, simply turn the engine switch to the OFF position. Under normal conditions, use the following procedure:

1. Move the throttle lever to the SLOW  position.
2. Let the engine idle for one or two minutes.
3. Turn the engine switch to the OFF position.
4. Turn the fuel valve lever to the OFF  position.



**Sudden stopping at a high speed under a heavy load is not recommended. Engine damage may result.**



**Do not move the choke control to CLOSE to stop the engine. Backfire or engine damage may occur.**

## MAINTENANCE

Maintaining your dump cart will ensure long life to the machine and its components.

### Preventive Maintenance

1. Turn off the engine and disengage all command levers. The engine must be cool.
2. Keep the engine's throttle lever in its SLOW position and remove the spark plug wire from the spark plug and secure.
3. Inspect the general condition of the dump cart. Check for loose screws, misalignment or binding of moving parts, cracked or broken parts, and any other condition that may affect its safe operation.
4. Use a soft brush, vacuum or compressed air to remove all contaminants from the machine. Then use high quality light oil to lubricate all moving parts.
5. Check the spark plug wire regularly for signs of wear, and replace when needed.



**Never use a "pressure washer" to clean your unit. Water can penetrate tight areas of the machine and its transmission case and cause damage to spindles, gears, bearings, or the engine. The use of pressure washers will result in shortened life and reduce serviceability.**

### Adjusting Clutch

When the clutch begins to show wear, the handle reach will become wider, making it more difficult to reach. Follow these steps to return the clutch lever back to its original position.

1. Loosen the jam nut by turning it counter clockwise with 0.4 in wrench.
2. Tighten or loosen the cable by turning the cable adjustment nut clockwise or counter clockwise with 0.4 in wrench until you have reached your required tightness.

3. Once tightness is set, return the jam nut against the handle to hold the cable in place.

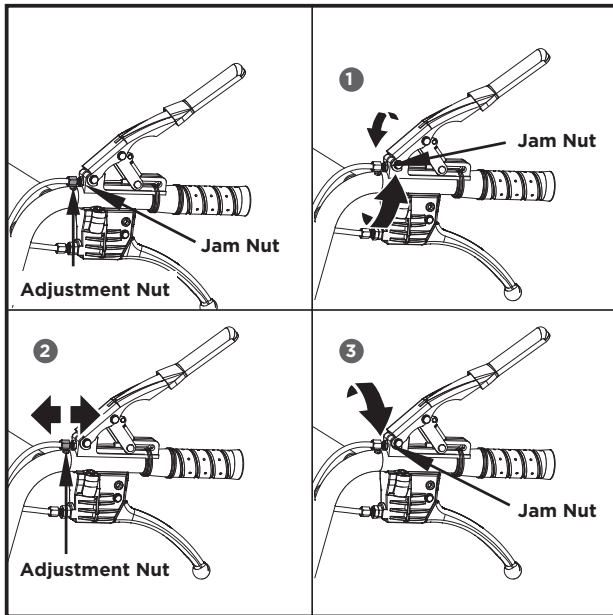

### Adjusting Steering

If steering becomes difficult to engage follow these steps to adjust the cable tension.

1. Loosen the jam nut by turning it counter clockwise with 0.4 in wrench.
2. Tighten or loosen the cable by turning the cable adjustment nut clockwise or counter clockwise with 0.4 in wrench until you have reached your required tightness.
3. Once tightness is set, return the jam nut against the handle to hold the cable in place.

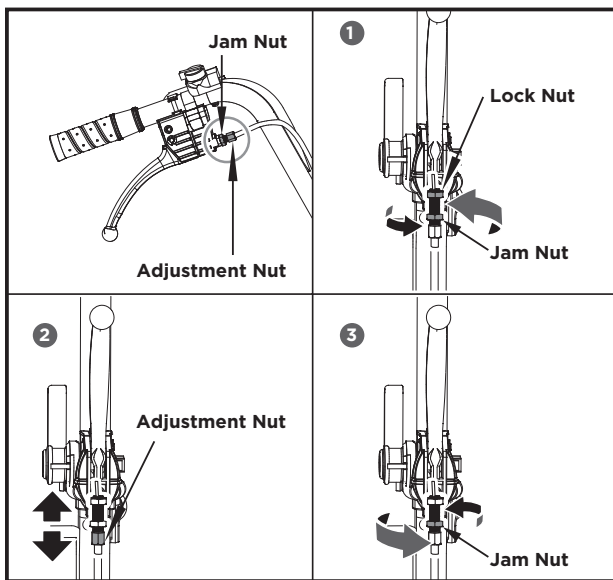

If the above adjustment does not create enough cable tension, follow the steps below:

1. Loosen the jam nut by turning it counter clockwise with 0.47 in wrench.
2. Tighten or loosen the cable by turning the cable adjustment nut clockwise or counter clockwise with 0.4 in wrench until you have reached your required tightness.
3. Once tightness is set, return the jam nut against the handle to hold the cable in place.

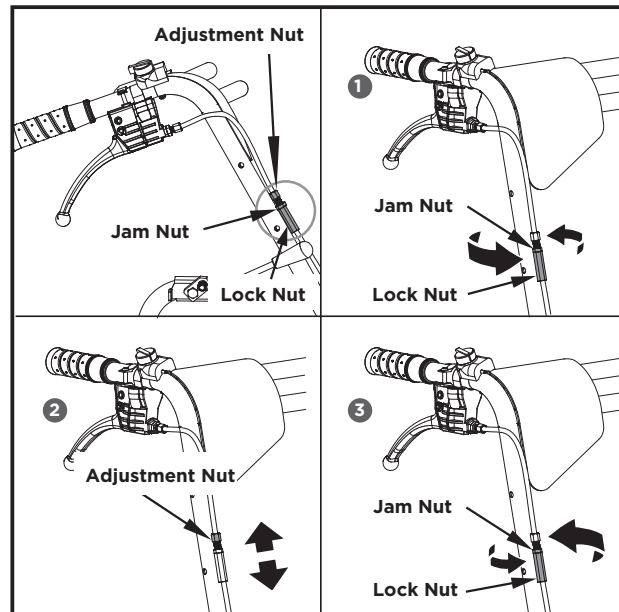

### Replacing Drive Belt

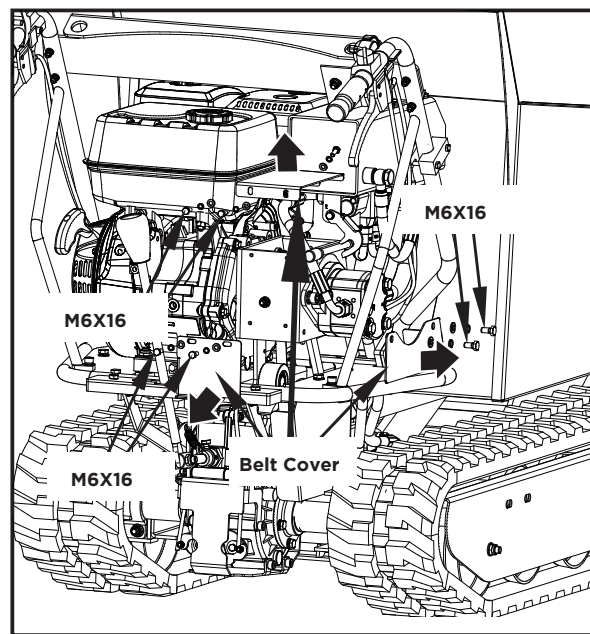

Remove the belt cover for gearbox pulley.

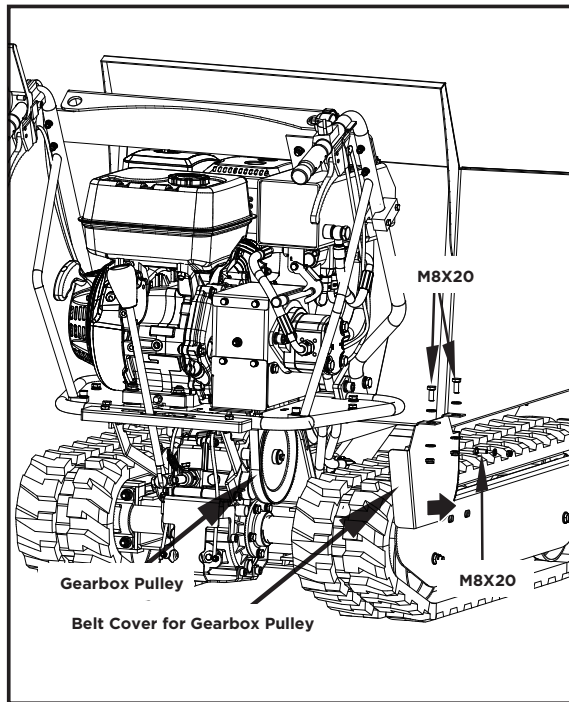

Disassemble the two M8X20 bolts, spring washers and flat washers, remove the pump with flange.

Turn the gearbox pulley and pull out the belt.

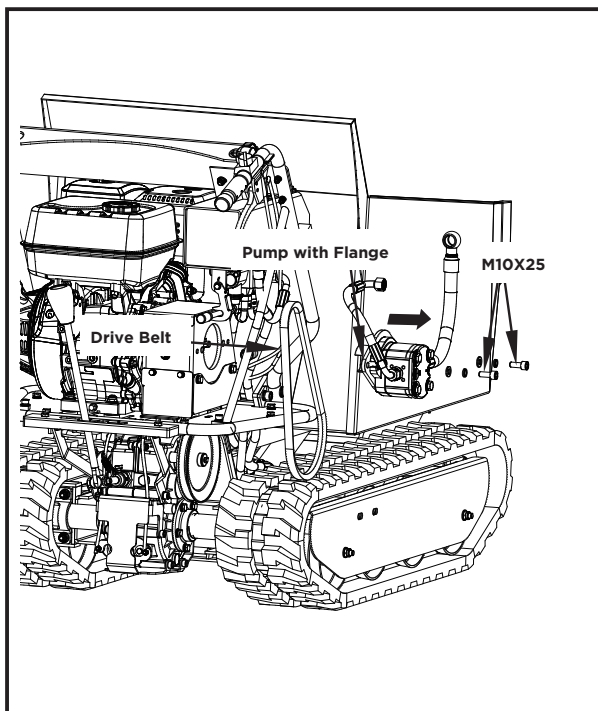

## Lubrication

### General Lubrication

Lightly lubricate all moving parts of the machine at end of the season or every 25 operating hours.

### Gearbox Lubrication

The gearbox is pre-lubricated and sealed at the factory. Unless there is evidence of leakage or service has been performed on the gearbox, no additional lubricate should be required until 50 hours use.

After first 50 hours use, change all the gear oil. Capacity is 1.5L.

For future use, check the oil level after every 50 hours of use. If you remove the oil level plug and no oil flows out, please add oil and then screw the oil level plug.

Gear oil GL-5 or GL-6, SAE80W-90 is recommended. Do not use synthetic oil.

When replacing gear oil, the engine must be stopped and still warm. Unscrew the filter cap and the drain plug. When oil is drained, replace the drain plug, fill up with fresh oil, and then replace the filter cap.

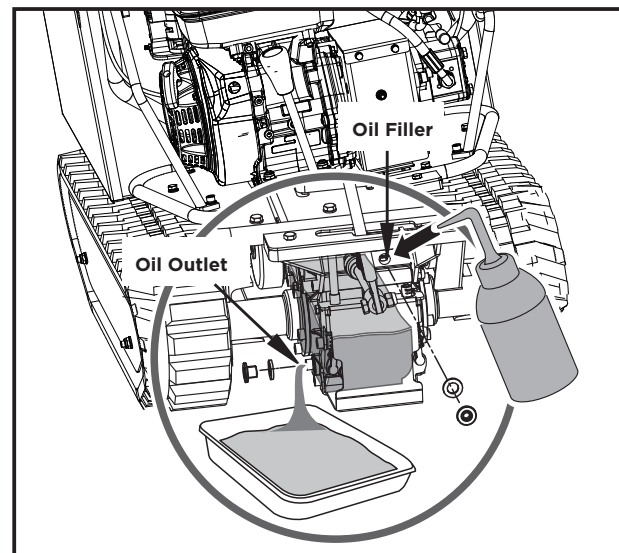

## Hydraulic Oil

Unscrew the locking nut to drain the oil into the pan.

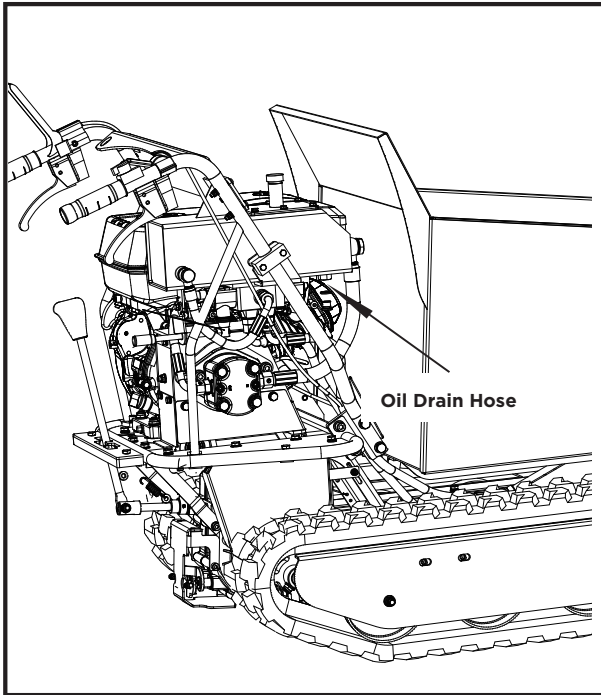

Remove the dipstick and add the oil. The recommended hydraulic oil is 10W AW32, ASLE H-150, or ISO 32. Tank Capacity is 3L.

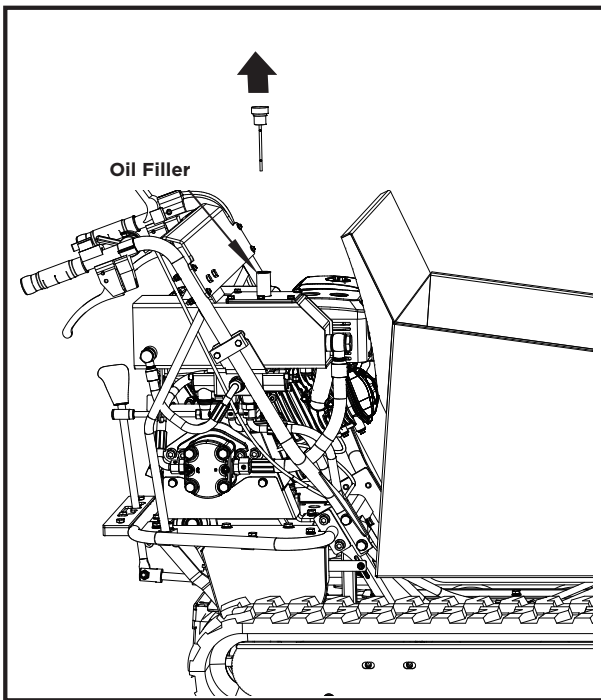

## Tightening Tracks

With use, tracks tend to loosen. When operating with loose tracks, they tend to slip over the driving wheel causing it to jump its housing, thus damaging wear to the housing.

To check track tightness, proceed as follows.

1. Set the machine on a flat surface with compact ground, or on asphalt or pavement.
2. Lift the machine and set it on blocks or supports rated for the weight of the machine so that the tracks are approximately 4" off the ground.
3. Measure the track midline vs. the horizontal line. The reading must not be more than 0.4 in-0.6 in.

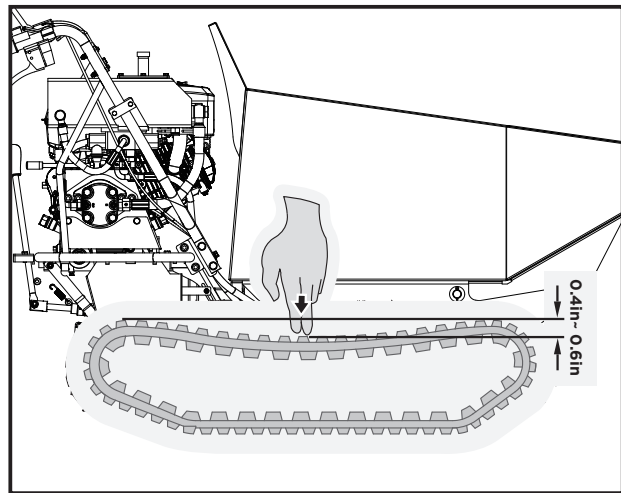

If the distance is greater, proceed as follows.

1. Use the tipping handle to tip the hopper and set it on blocks or supports rated for the weight of the box.
2. Loosen locknut A.
3. Tighten bolt B until the correct tightness is restored.
4. Secure bolt B by tightening locknut A thoroughly.
5. Return the hopper to its original position.

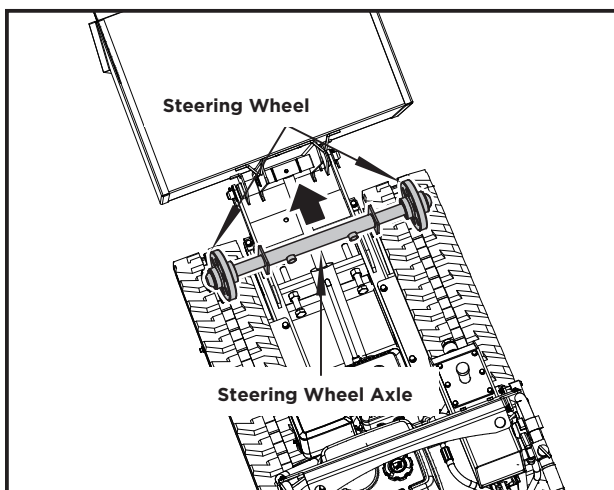
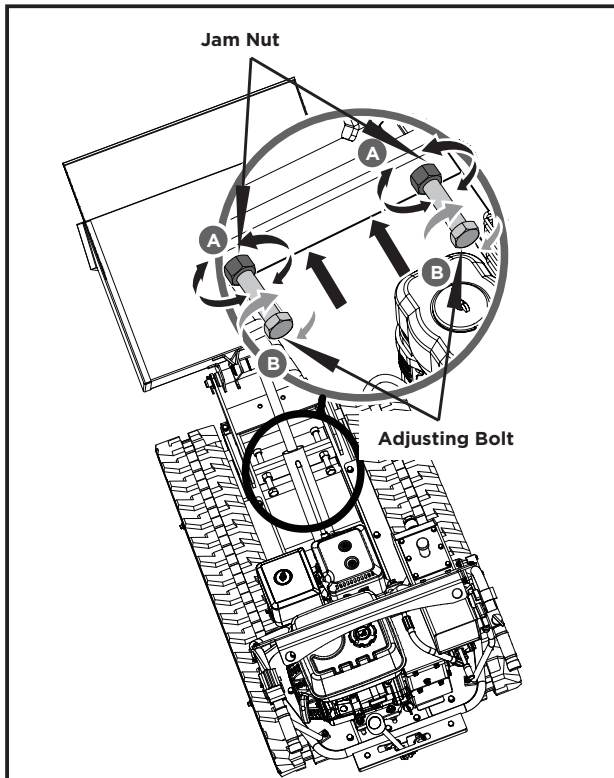

Do not over-tighten your track. The adjustment of the track and the brakes are linked. The braking power will lessen the more the track is tightened.



If the adjustment bolt has no more adjustment left, the tracks may have to be replaced.

## Replacing Tracks

Check the condition of the tracks periodically. If any track is cracked or frayed, it should be replaced as soon as convenient.

1. Lift up the hopper and insert a support rod for safety purposes.
2. Lift the machine and set it on blocks or supports rated for the weight of the machine so that the tracks are approximately 4 in off the ground.

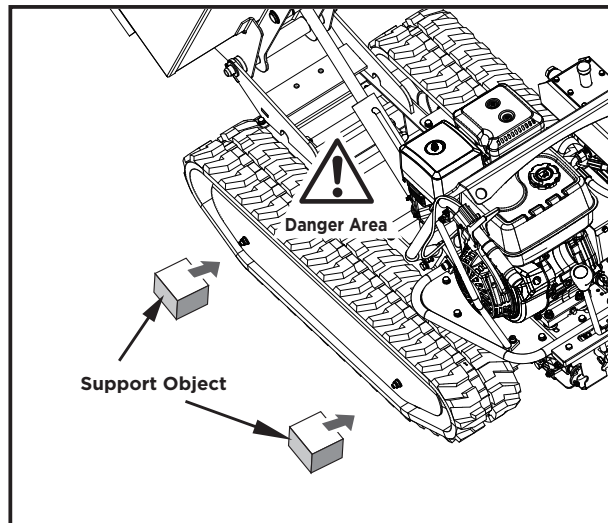

3. Remove the three M8×16 bolts and washers that fix the track protection guard.

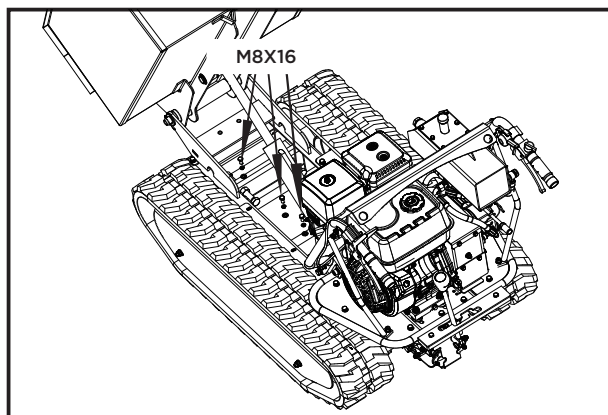

4. Remove the two M10 nuts and washers from the side of track protection guard and take off the track protection guard.

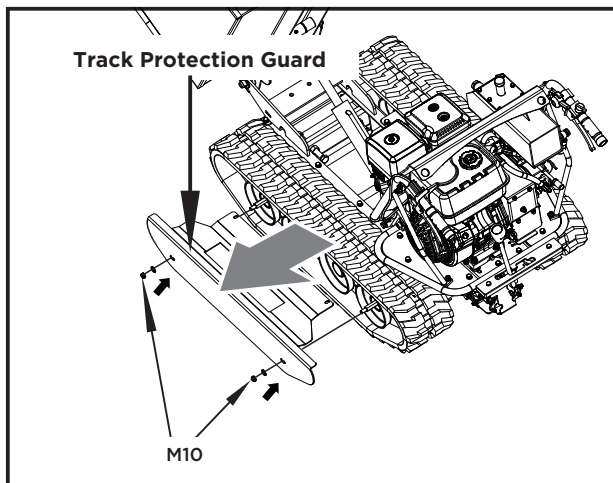

5. Loosen the adjusting bolts and pull the steering wheel axle toward the engine, then track will be loosen.

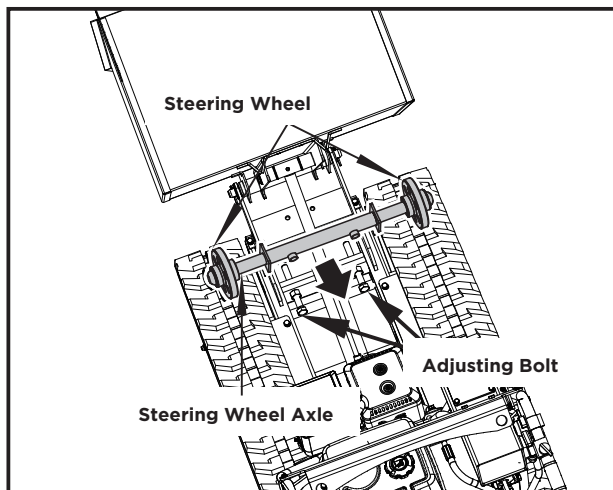

6. Remove the M10× 60 bolt, washers and nut from the driving wheel.

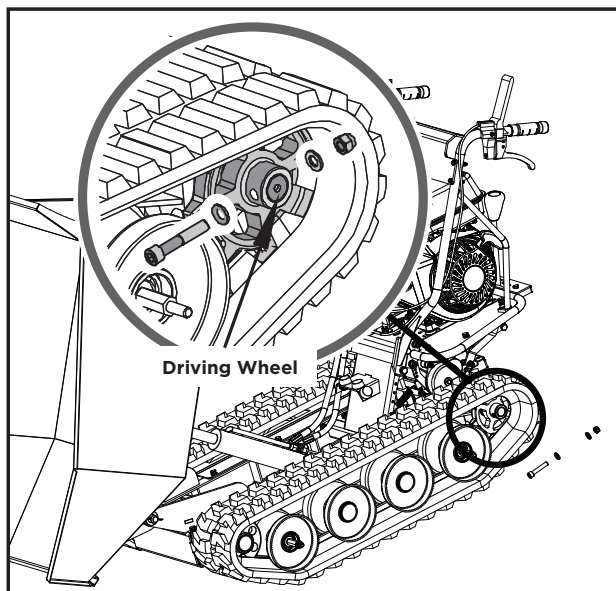

7. Pull out the whole track with driving wheel.

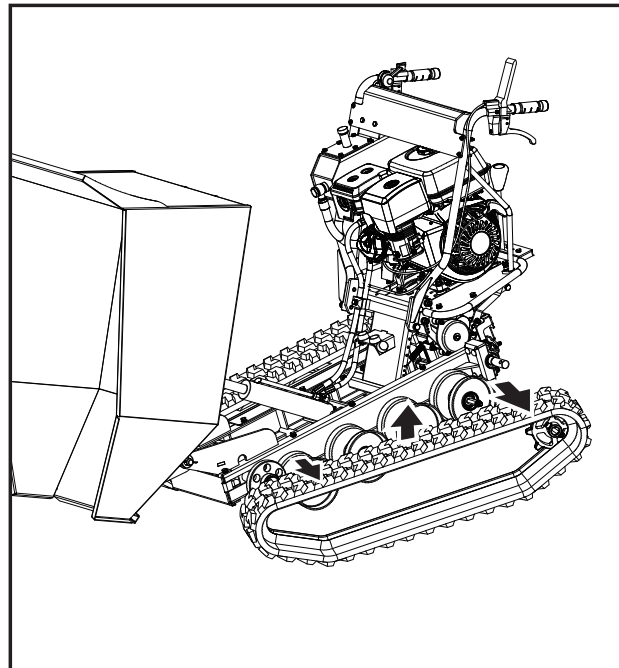

When removing or installing the tracks, be careful not to get your fingers caught between the track and pulley.

#### ENGINE MAINTENANCE

Refer to the Engine Manual included in your unit for the information on engine maintenance. Your engine manual provides detailed information and a maintenance schedule for performing the tasks.

## STORAGE

If the mini track dumper will not be used for a period longer than 30 days, follow the steps below to prepare your unit for storage.

1. Drain the fuel tank completely. Stored fuel containing ethanol or MTBE can start to go stale in 30 days. Stale fuel has high gum content and can clog the carburetor and restrict fuel flow.
2. Start the engine and allow it to run until it stops. This ensures no fuel is left in the carburetor. Run the engine until it stops. This helps prevent gum deposits from forming inside the carburetor and possible engine damage.
3. While the engine is still warm, drain the oil from the engine. Refill with fresh oil of the grade recommended in the **Engine Manual**.
4. Use clean cloths to clean off the outside of the machine and to keep the air vents free of obstructions.



**Do not use strong detergents or petroleum based cleaners when cleaning plastic parts. Chemicals can damage plastics.**

5. Inspect for any loose or damaged parts. Repair or replace damaged parts and tighten loose screws, nuts or bolts.
6. Store your unit on flat ground in a clean, dry building that has good ventilation.



**Do not store the machine with fuel in a non-ventilated area where fuel fumes may reach flame, sparks, pilot lights or any ignition sources.**

## HYDRULIC SCHEME

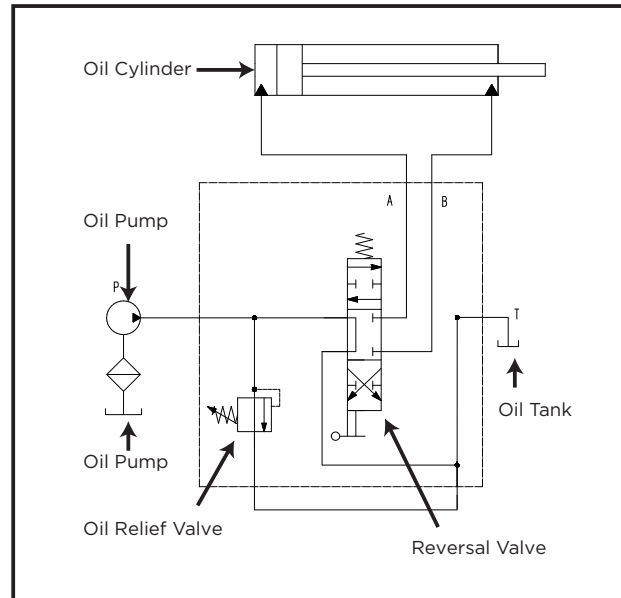

# TROUBLE SHOOTING

GB

Problem	Cause	Remedy
Engine fails to start.	<ol style="list-style-type: none"> <li>1. Spark plug wire disconnected.</li> <li>2. Out of fuel or stale fuel.</li> <li>3. Choke not in open position.</li> <li>4. Blocked fuel line.</li> <li>5. Fouled spark plug.</li> <li>6. Engine flooding.</li> </ol>	<ol style="list-style-type: none"> <li>1. <b>Attach spark plug wire securely to spark plug.</b></li> <li>2. <b>Fill with clean, fresh gasoline.</b></li> <li>3. <b>Throttle must be positioned at choke for a cold start.</b></li> <li>4. <b>Clean the fuel line.</b></li> <li>5. <b>Clean, adjust gap, or replace.</b></li> <li>6. <b>Wait a few minutes to restart, but do not prime.</b></li> </ol>
Engine runs erratically.	<ol style="list-style-type: none"> <li>1. Spark plug wire loose.</li> <li>2. Unit running on CHOKE.</li> <li>3. Blocked fuel line or stale fuel.</li> <li>4. Vent plugged.</li> <li>5. Water or dirt in fuel system.</li> <li>6. Dirty air cleaner.</li> <li>7. Improper carburetor adjustment.</li> </ol>	<ol style="list-style-type: none"> <li>1. <b>Connect and tighten spark plug wire.</b></li> <li>2. <b>Move choke lever to OFF.</b></li> <li>3. <b>Clean fuel line. Fill tank with clean, fresh gasoline.</b></li> <li>4. <b>Clear vent.</b></li> <li>5. <b>Drain fuel tank. Refill with fresh fuel.</b></li> <li>6. <b>Clean or replace air cleaner.</b></li> <li>7. <b>Refer to Engine Manual.</b></li> </ol>
Engine overheats.	<ol style="list-style-type: none"> <li>1. Engine oil level low.</li> <li>2. Dirty air cleaner.</li> <li>3. Air flow restricted.</li> <li>4. Carburetor not adjusted properly.</li> </ol>	<ol style="list-style-type: none"> <li>1. <b>Fill crankcase with proper oil.</b></li> <li>2. <b>Clean air cleaner.</b></li> <li>3. <b>Remove housing and clean.</b></li> <li>4. <b>Refer to Engine Manual.</b></li> </ol>
One of the two tracks is blocked.	Foreign bodies have worked their way between the track and the frame.	<b>Remove the foreign body.</b>
Machine does not move while engine is running.	<ol style="list-style-type: none"> <li>1. Gear is not properly selected.</li> <li>2. Driving tracks not tight enough.</li> </ol>	<ol style="list-style-type: none"> <li>1. <b>Ensure gear lever is not in-between two different gears.</b></li> <li>2. <b>Tighten driving tracks.</b></li> </ol>

# PARTS DIAGRAM

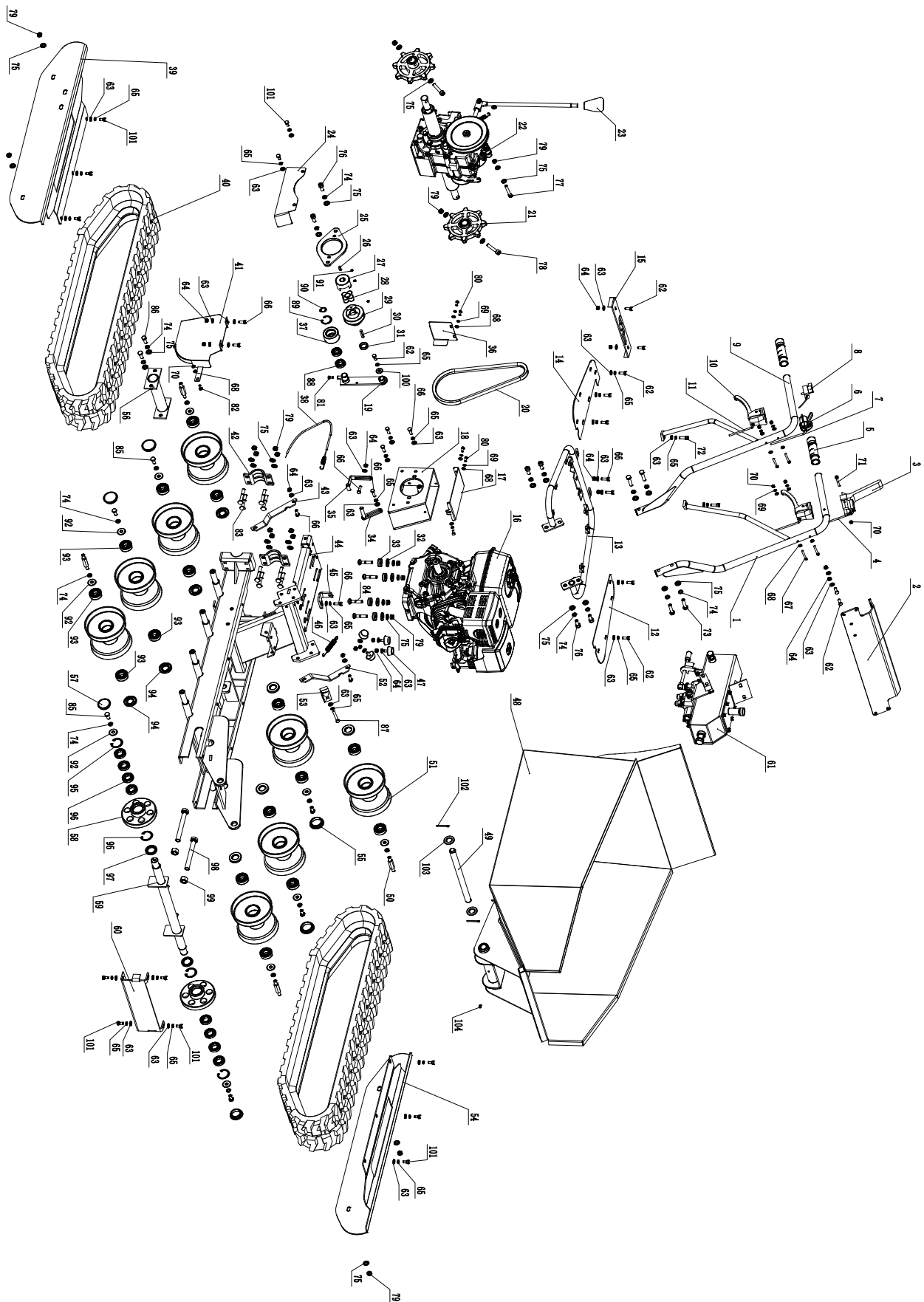

# PARTS LIST

GB

No.	Description	Q'ty
1	Handle frame assembly (left)	1
2	Plate	1
3	Safety control handle	1
4	Tensioner pulley cable	1
5	Handle sleeve	2
6	Throttle lever	1
7	Throttle cable	1
8	ON/OFF Switch	1
9	Handle frame assembly (right)	1
10	Brake lever	1
11	Steering lever cable	2
12	Soleplate (left)	1
13	Handle mounting frame	1
14	Soleplate (right)	1
15	Gear shift plate	1
16	Engine	1
17	Pump bracket cover	1
18	Pump bracket	1
19	Tensioner pulley bracket	1
20	Belt	1
21	Driving wheel	1
22	Gearbox assembly	2
23	Lever knob	1
24	Pump bracket side plate	1
25	Pump mounting flange	1
26	Pump flat key	1
27	Shaft coupling (pump side)	1
28	Plum elastic cushion	1
29	Shaft coupling (engine side)	1
30	Engine flat key	1
31	Engine shaft sleeve	1
32	Gasket	4
33	Rubber shock pad	4
34	Front belt limit board	1
35	Rear belt limit board	1
36	Pump bracket back plate	1
37	Tensioner pulley	1
38	Brake cable	1

No.	Description	Q'ty
39	Guard plate (right)	1
40	Rubber track	1
41	Lower belt cover	1
42	Wheel axle mounted plate	2
43	Support plate (right)	1
44	Chassis	1
45	Cable fixing base	1
46	Brake spring	1
47	Rubber mat	4
48	Dumper box assembly	1
49	Connecting pin	1
50	Stud	4
51	Track roller	8
52	Support plate (left)	1
53	Pipe clamp	1
54	Guard plate (left)	1
55	Plastic plug	4
56	Supporting bracket weldment	1
57	Plastic plug	2
58	Guiding wheel	2
59	Guiding wheel axle	1
60	Front cover	1
61	Hydraulic system assembly	1
62	Hex bolt M8x20	13
63	Flat washer 8	45
64	Lock nut M8	15
65	Spring washer 8	27
66	Hex bomot M8x25	9
67	Hex socket bolt M6x45	4
68	Flat washer 6	14
69	Spring washer 6	9
70	Lock nut M6	6
71	Hex socket bolt M6x50	1
72	Hex socket bolt M8x25	2
73	Hex bolt M10x45	4
74	Spring washer 10	22
75	Flat washer 10	36
76	Hex socket bolt M10x25	6

MINI TRACK DUMP CART

**GB**

No.	Description	Q'ty
77	Hex socket bolt M10x65	1
78	Hex socket bolt M10x55	2
79	Lock nut M10	19
80	Hex bolt M6x16	5
81	Hex bolt M6x12	1
82	Carriage bolt M6x20	1
83	Carriage bolt M10x65	8
84	Carriage bolt M10x50	4
85	Hex bolt M10x20	6
86	Hex bolt M10x25	2
87	Hex bolt M8x50	1
88	Bearing 61904	2
89	Circlip 37	1
90	Circlip 20	1
91	Hex socket bolt M6x6	3
92	Gasket 10	10
93	Bearing 6204	16
94	Oil seal	8
95	Circlip 42	4
96	Bearing 61905	8
97	Oil seal	2
98	Hex bolt M16x140	2
99	Hex nut M16	2
100	Gasket 8	1
101	Hex bolt M8x16	12
102	Split pin 4x40	2
103	Flat washer 22	2
104	Oil cup M6	1

# Hydraulic Assembly

GB

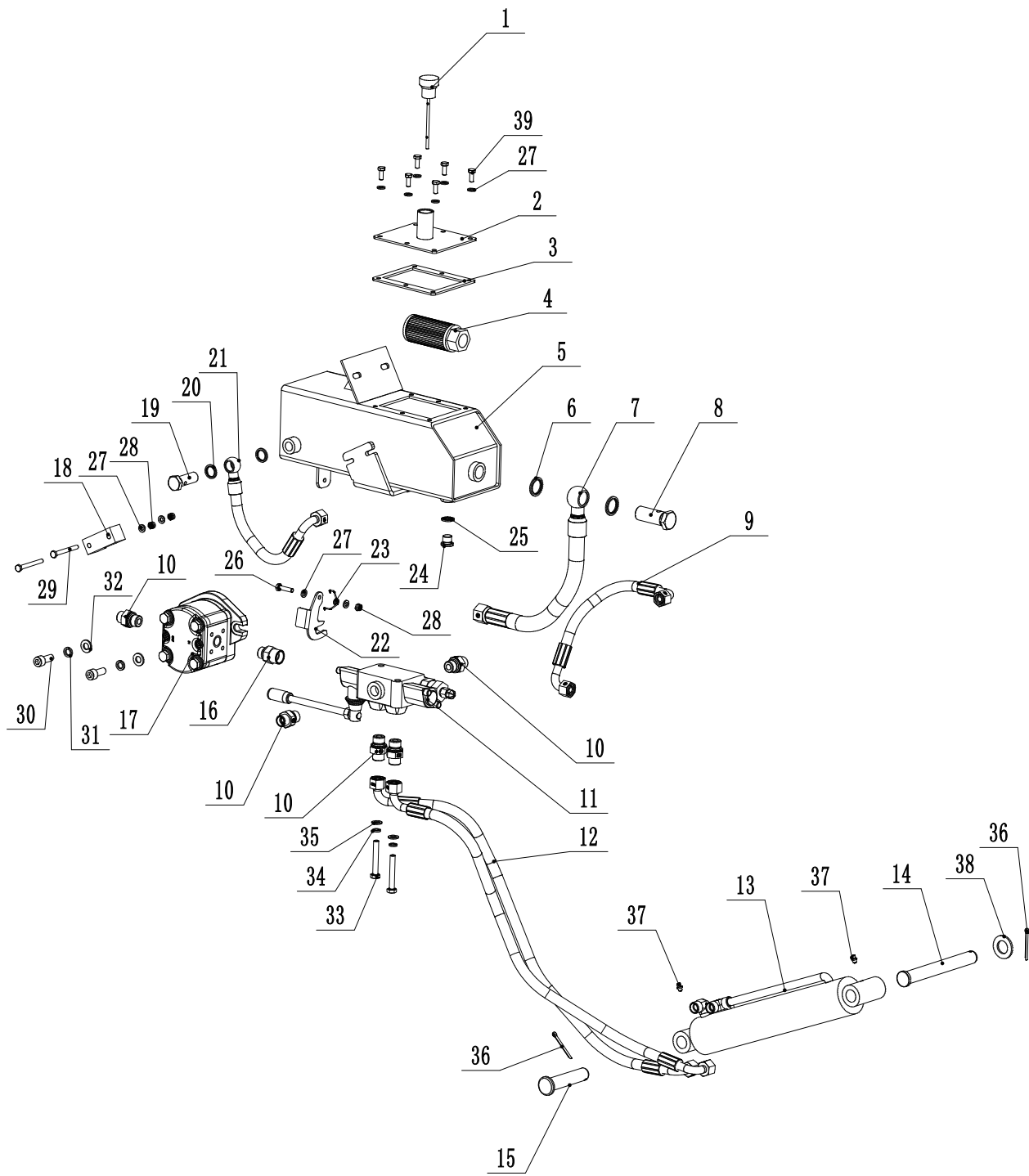

## PARTS LIST

No.	Description	Q'ty
1	Dipstick	1
2	Tank cover	1
3	Sealing gasket	1
4	Oil filter	1
5	Hydraulic tank	1
6	Combinded sealing gasket 22	2
7	Oil suction pipe	1
8	Link bolt 700M-22	1
9	Oil outlet pipe	1
10	Control valve	5
11	Control valve	1
12	Rubber hose	2
13	Cylinder	1
14	Spindle 1	1
15	Spindle 2	1
16	Connector 1CM-22-20WD	1
17	Gear pump	1
18	Tank fixing bracket	1
19	Link bolt 700M-16	1
20	Combinded sealing gasket 16	2
21	Oil return pipe	1
22	Handle limit plate	1
23	Torsional spring	1
24	Hex socket plug M14x1.5	1
25	Combinded sealing gasket 14	1
26	Hex bolt M6x25	1
27	Flat washer 6	10
28	Lock nut M6	3
29	Hex bolt M6x55	2
30	Hex socket bolt M10x25	2
31	Spring washer 10	2
32	Flat washer 10	2
33	Hex bolt M8x55	2
34	Spring washer 8	2
35	Flat washer 8	2
36	Spilt pin 4x40	2
37	Oil cup M6	2
38	Flat washer 20	1
39	Hex bolt M6x16	6



**DKA**  **POWER**