

THE POWER OF

**REDARC**®

# Smart Start® SBI

Smart Battery Isolator

## MODELS:

- SBI12
- SBI24
- SBI212
- SBI224
- Dual-Sensing

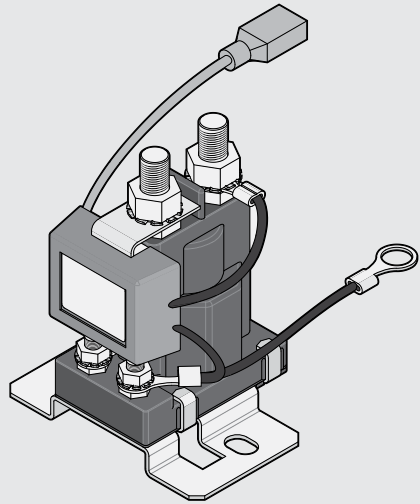
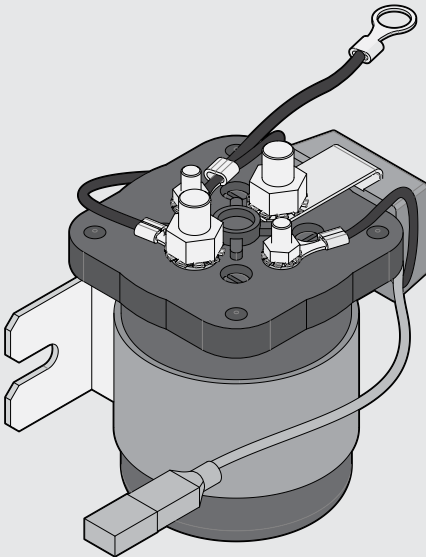

# WARNINGS & SAFETY INSTRUCTIONS

**Save these instructions** – this manual contains important safety instructions. Do not operate the system unless you have read and understood this manual. REDARC recommends that the Smart Start® SBI referenced in this manual be installed by a suitably qualified person.

**Disclaimer:** REDARC accepts no liability for any injury, loss or property damage which may occur from the improper or unsafe installation or use of its products.

## SAFETY MESSAGE CONVENTIONS

Safety messages in this manual contain a signal word that indicates the level of the hazard, as follows:

### WARNING

Indicates a potentially hazardous situation which could result in death or serious injury to the operator or to bystanders.

### CAUTION

Indicates a potentially hazardous situation which may result in moderate or minor injury to the operator or to bystanders.

### NOTICE

Indicates a situation that may cause equipment damage.

### WARNING

**RISK OF EXPLOSIVE GASES – Working in vicinity of a lead-acid battery is dangerous. Batteries generate explosive gases during normal operation. For this reason, it is of utmost importance that you follow the instructions each time you use the charger.**

### CAUTION

1. Only use the Battery Isolator for charging Standard Automotive Lead Acid, Calcium Content, Gel, AGM, SLI or Deep Cycle type batteries.

2. Do NOT use the Battery Isolator to charge:

- Dry-cell batteries that are commonly used with home appliances.
- Batteries with voltage ratings other than 12V (or 24V for 24V unit)
- Non-rechargeable batteries
- A frozen Battery. Thaw completely before attempting to charge.

Charging batteries under these circumstances may cause the battery to explode or rupture during charging and cause injury to persons, damage to the Battery Isolator and/or property.

3. NEVER smoke or allow a spark or flame in vicinity of battery or engine. This may cause the battery to explode.

4. Be extra cautious so as to reduce the risk of dropping a metal tool onto a vehicle battery. Doing so might cause the battery to spark or might short-circuit the battery or other electrical parts that may cause an explosion.

5. Remove personal metal items such as rings, bracelets, necklaces, and watches when working with a lead-acid battery. A lead-acid battery can produce a short-circuit current high enough to weld a ring or the like to metal, causing a severe burn.

**6. A SPARK NEAR A BATTERY MAY CAUSE THE BATTERY TO EXPLODE. TO REDUCE THE RISK OF A SPARK NEAR A BATTERY WHEN CONNECTING THE BATTERY INSTALLED IN A VEHICLE TO THE ISOLATOR, ALWAYS DO THE FOLLOWING:**

- a. Position DC cords to reduce the risk of damage by the vehicle hood, door, or moving engine part.
- b. Stay clear of fan blades, belts, pulleys and other parts that can cause injury to persons.
- c. Check polarity of battery posts. The POSITIVE (POS / P / +) battery post usually has a larger diameter than the NEGATIVE (NEG / N / -) battery post however you should always check the label on the battery.
- d. Determine which post of the battery is grounded (connected) to the chassis. If the negative post is grounded to the chassis (as in most vehicles), see (e). If the positive post is grounded to the chassis see (f).
- e. For a negative-grounded vehicle, connect the POSITIVE (Red) terminals from the Battery Isolator to the POSITIVE (POS, P, +) ungrounded post of each battery. Connect the NEGATIVE (Black) lead to a metal part of the frame or the vehicle chassis, away from the battery. Do not connect the connect to the carburettor or fuel lines.
- f. For positive-grounded vehicles, connect the NEGATIVE (Black) lead from the Battery Isolator to the NEGATIVE (NEG / N / -) ungrounded post of the battery. Connect the POSITIVE (RED) terminals to the POSITIVE (POS / P / +) post of each battery. Do not connect the connect to the carburettor, fuel lines, or sheet-metal body parts. Only the start battery should be connected to the chassis.

## PERSONAL SAFETY PRECAUTIONS:

To assist with the safe working with batteries:

1. Consider having someone close by to come to your aid when you are working with the Battery.
2. Have plenty of fresh water and soap nearby in case battery acid contacts skin, clothing, or eyes.
3. Wear complete eye protection and clothing protection. Avoid touching eyes while working near a battery.
4. If battery acid contacts your skin or clothing, remove the affected clothing and wash the affected area of your skin immediately with soap and water. If battery acid enters your eye, immediately flood the eye with running cold water for at least 10 minutes and seek medical assistance immediately.

## NOTICE

1. It is recommended that Start and Auxiliary Batteries be of similar chemical characteristics when charging via the Smart Start® SBI.
2. The Smart Start® SBI will achieve best results when proper battery maintenance is regularly performed. This includes but is not limited to checking water and specific gravity levels of the battery. Refer to the battery manufacturers manual for more details.
3. Fuses or Circuit breakers of appropriate rating must be installed to protect the vehicle system. Refer to the installation instructions for specific instructions on where to install Fuses or Circuit breakers. Refer to the cable sizing table found in this manual for appropriate Fuse or Circuit Breaker ratings.
4. Fuses must be installed as close as possible to the battery.
5. **IMPORTANT!** Do NOT make any connections to the control terminals on the front of the unit (100 A models) or the top of the unit (200 A models). Connecting to the control terminals on the front of the SBI may cause damage to the unit and/or equipment connected to it. Connecting to the control terminals will void the warranty of the unit.

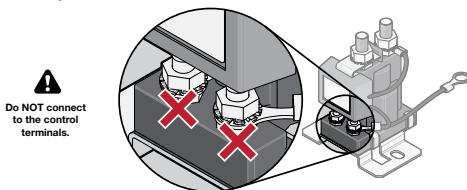

**IMPORTANT!** Ensure that connections are not accidentally bridged between terminals whilst tightening.

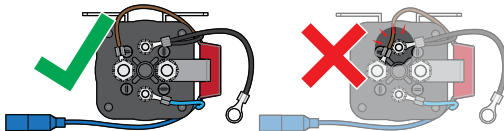

## LIMITED WARRANTY

For full warranty terms and conditions, visit the Warranty page of the REDARC website at [www.redarcelectronics.com/warranty](http://www.redarcelectronics.com/warranty).

Refer to the contact details applicable to your region:

### Australia, New Zealand & Europe

REDARC Electronics Pty Ltd, 23 Brodie Road (North), Lonsdale SA 5160, Australia.

<b>Australia</b>	+61 8 8322 4848
<b>New Zealand</b>	+64-9-222-1024
<b>UK &amp; Europe</b>	+44 (0)20 3930 8109

### North America

REDARC Corporation c/o Shallco, Inc.,  
308 Component Dr.  
Smithfield, NC 27577, USA.

<b>USA</b>	+1 (704) 247-5150
<b>Canada</b>	+1 (604) 260-5512
<b>Mexico</b>	+52 (558) 526-2898

# PRODUCT FUNCTION

The Smart Start® SBI is a microprocessor controlled Smart Battery Isolator and is designed specifically for use in multi battery applications as a solenoid priority system. It protects the start battery from being excessively discharged by auxiliary loads, whilst still allowing the auxiliary battery to supply non essential loads.

Put simply, once the start battery has had some charge from the alternator, the Smart Start® SBI will connect an auxiliary battery to the charge circuit. Similarly, if the start battery voltage drops too low, the Smart Start® SBI will disconnect any auxiliary batteries or loads from the start battery to conserve charge.

## MOUNTING

- Mount the Smart Start® SBI securely in a convenient location **near the start battery bank**.
- **Do not mount in direct engine heat.**

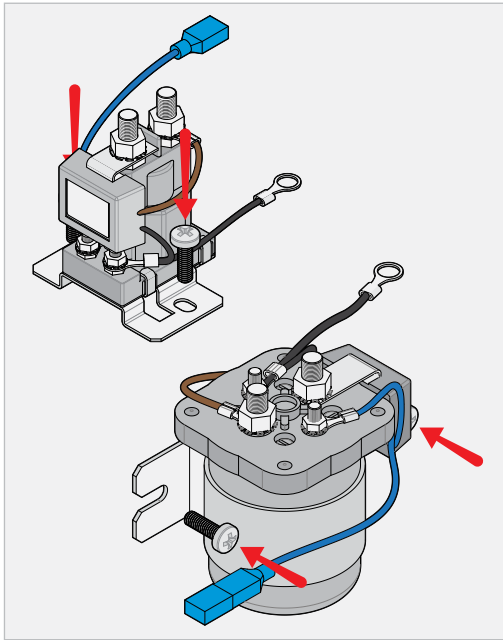

## RECOMMENDED FUSES

REDARC Fuse Kits are recommended as they contain high quality, reliable fuses and fuse holders.

### SBI12/SBI24:

- **FK60**  
MIDI 60 A Fuse Kit

### SBI212/SBI224:

- **FK100**  
MEGA 100 A Fuse Kit

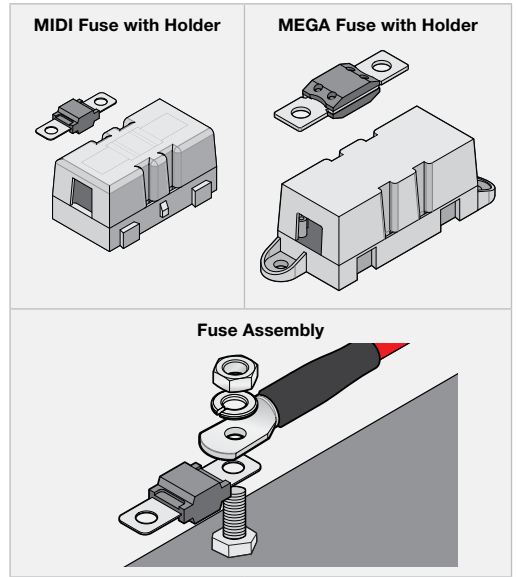

## CABLE SIZING

Model	Wire Length	Start Feature with Pushbutton Override		No Override		Main Stud Torque
		Circuit Breaker/Fuse	Wire	Circuit Breaker/Fuse	Wire	
SBI12 / SBI24	Up to 3m	100A	19 mm <sup>2</sup> (4 B&S)	60A	8 mm <sup>2</sup> (8 B&S)	5 – 6.2Nm
	3m to 6m	100A	32 mm <sup>2</sup> (2 B&S)	60A	13 mm <sup>2</sup> (6 B&S)	5 – 6.2Nm
SBI212 / SBI224	Up to 3m	200A	32 mm <sup>2</sup> (2 B&S)	120A	19 mm <sup>2</sup> (4 B&S)	6.5 Nm max.
	3m to 6m	200A	40 mm <sup>2</sup> (1 B&S)	120A	25 mm <sup>2</sup> (3 B&S)	6.5 Nm max.

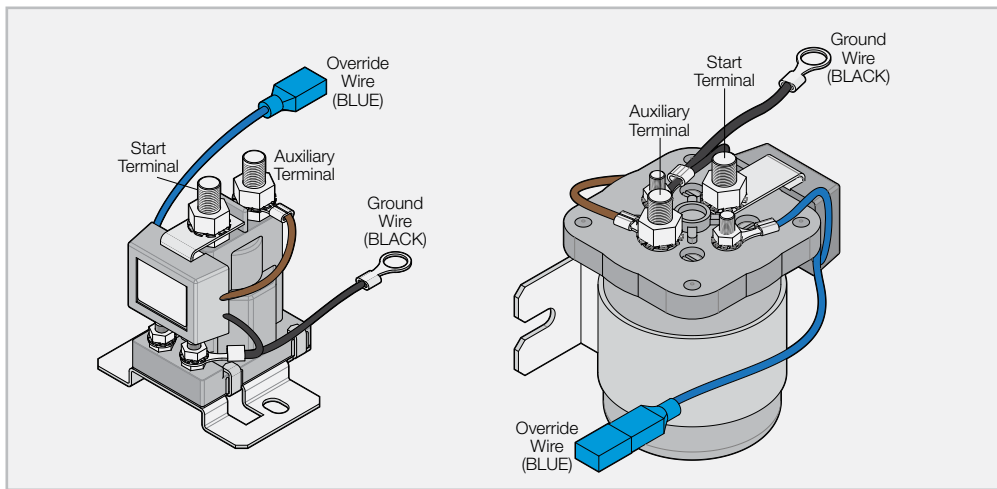

## STANDARD WIRING DIAGRAM

- Ensure adequately sized cable is used.
- Ensure the auxiliary battery is properly grounded to a common chassis earth point.
- Ensure the SBI ground wire is making good contact with the chassis ground point.
- When using fuses make sure that the fuse makes a good low resistance connection.
- Fuse/Circuit Breaker ratings are dependent on the type of installation and the size of the loads.

## WIRING

1. Make sure the auxiliary battery negative is properly grounded to the vehicle chassis. **(1)**
2. Ground Connection. Connect the Smart Start® SBI ground terminal to chassis ground. Remove any paint to ensure a good ground connection.  
**NOTE:** A good ground will ensure correct switching voltage. **(2)**
3. Select correct Circuit Breaker/Fuse sizes and install at battery end of both positive cables. **(3)**
4. Connect the cables in the order shown as shown below. **(4, 5, 6, 7)**

\*When using fuses make sure that the fuse makes a good low resistance connection. Circuit Breaker/Fuse ratings are dependent on the type of installation and the size of the loads.

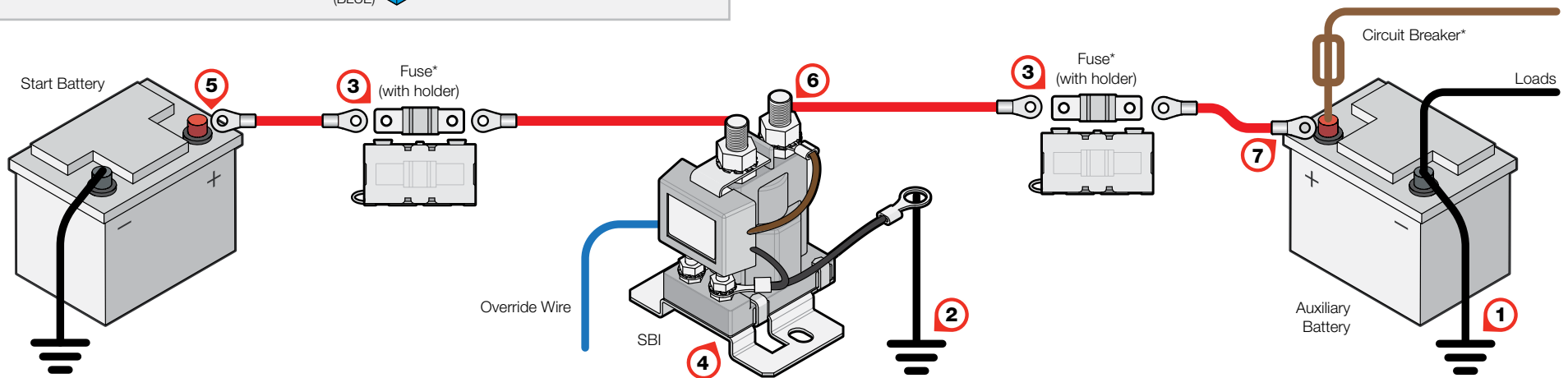

## LED CONNECTIONS (OPTIONAL)

Connect a wire from the Blue wire of the Smart Start® SBI to the positive end of an indicator LED (15 mA limited current draw) or LED/resistor combination mounted on the vehicle dash.

## START ASSIST FEATURE (OPTIONAL)

1. Connect a wire from the Blue wire of the Smart Start® SBI to one terminal of a momentary push button switch.
2. Connect the other terminal of the momentary push button switch to the auxiliary battery supply.

To manually operate the Smart Start® SBI, hold the momentary push button switch and the Smart Start® SBI will manually operate until the switch is released. After about 10 seconds start the vehicle with the button still held on. The Smart Start® SBI should now be operational.

SBI with external LED

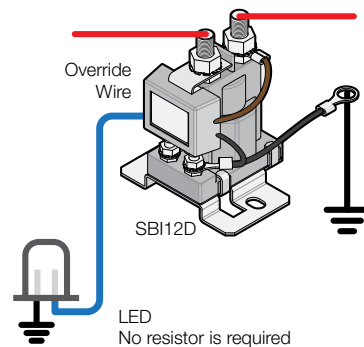

SBI with Push Button and LED

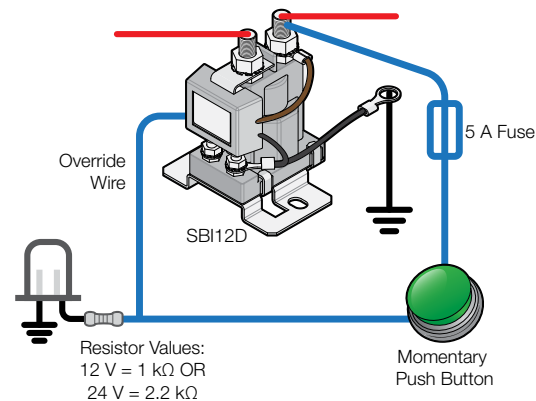

SBI with Push Button for Start Assist

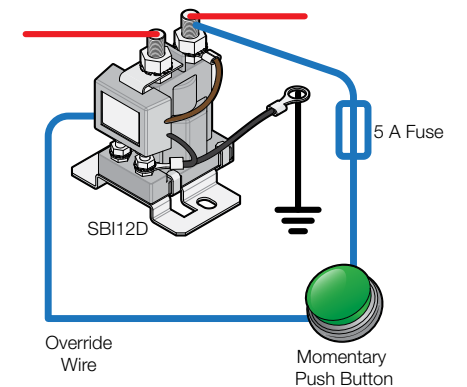

## DUAL SENSING MODELS WIRING DIAGRAM

Dual Sensing Smart Start® SBI's or 'D' Series SBI's monitor both the start battery and the auxiliary. If the unit detects that either battery has exceeded 13.2 V the isolator will be connected. Dual control provides the benefit of being able to charge the main battery from a solar panel or battery charger on the auxiliary battery.

The SBI12D has the added feature of allowing charge both ways.

\*When using fuses make sure that the fuse makes a good low resistance connection. Circuit Breaker/Fuse ratings are dependent on the type of installation and the size of the loads.

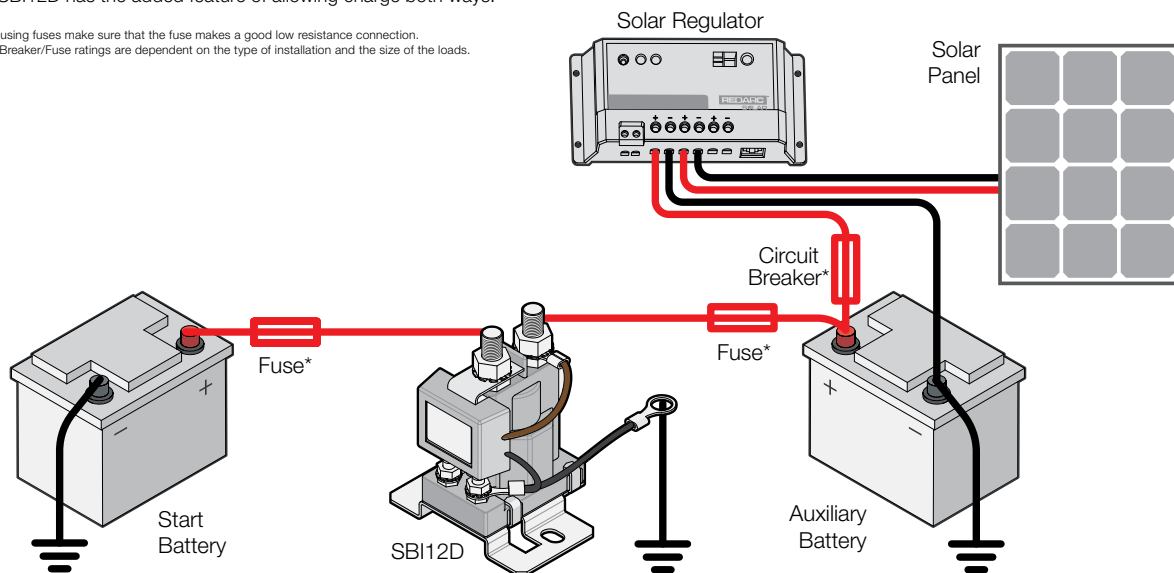

## FAULT INDICATION

**NOTE:** The LED may stay ON for a period after the vehicle is turned OFF. This is NOT a fault.

Should a fault occur, the Smart Start® SBI is set to notify the operator of the fault. The LED will flash repeatedly with the following sequences:

<b>CODE 1</b>	2 Flashes	Over-Voltage
<b>CODE 2</b>	3 Flashes	Voltage Drop or Excessive Current Draw Fault

### Fault code 1:

If the batteries connected to either terminal of the Smart Start® SBI should rise above 15.5V (31V on a 24V system), the Smart Start® SBI will do the following:

- Disconnect, if connected. This is to prevent the source of over-voltage reaching the other battery.
- Flash the LED 2 times for 20 seconds, then reassess the fault condition, continuing until the fault is cleared.

### Fault Code 2:

If the Smart Start® SBI detects a voltage drop across its contacts of greater than 1V for more than 30 seconds then the unit will:

- Immediately protect itself by disconnecting the auxiliary battery; and
- Flash the LED 3 times for 20 seconds, then reassess the presence of a fault, continuing until the fault is cleared.

## CHECKING THE OPERATION

Once the Smart Start® SBI is installed follow the steps below to check your operation:

- Start the vehicle or apply a charge to the start battery.
- Once the start battery voltage rises to the 'ON Volts' level the Smart Start® SBI will activate, you will hear the solenoid click and see the LED illuminate.
- Now turn off the vehicle or remove the charger from the start battery. The Smart Start® SBI will disconnect the auxiliary battery once the voltage on the start battery drops to the OFF Volts level, you will hear the solenoid click and the LED will turn off.

**NOTE:** The amount of time it takes for the battery voltage to drop low enough for the solenoid to turn off will vary due to the battery condition, age and state of charge (for a new, fully charged battery, it may take days).

**NOTE:** Check the specification table of your Smart Start® SBI to see the specific voltage levels.

**NOTE:** As per above, the LED may stay ON for a period of time after the vehicle is turned OFF.

## FREQUENTLY ASKED QUESTIONS

### Why does the LED stay on after the vehicle is turned off?

The LED stays on (indicating the Smart Start® is On and the batteries are linked) until the voltage drops to 12.7 V (25.4 V for SBI24). This can take a few minutes to many hours, depending on size and state of charge of the batteries as well as load on the batteries. To test this feature of the Smart Start®, make sure the engine is turned off, then turn the headlights On. The Smart Start® LED should turn Off; this may take a couple of minutes.

### Is the unit protected against voltage spikes?

Yes, the Smart Start® SBI incorporates a number of spike protection components specifically designed to reduce the risk of damaging the unit. The Smart Start® SBI is also designed to prevent any spikes generated by the solenoid coil from affecting any vehicle equipment.

### What does the red LED indicate?

The red LED indicates the solenoid is activated and both batteries are connected together and therefore are both being charged simultaneously. A flashing red LED during operation indicates a fault. See "Fault indication".

### Does the internal LED illuminate when I use the external override switch?

Yes.

### Can the voltage limits and time delay settings be changed?

Yes. Both upper and lower voltage limits & on and off times can be changed. However, this needs to be done at the time of manufacture and will incur a relatively minor cost.

### We are experiencing repetitive switching of our Smart Start® SBI. What could be causing this?

This can occur for one of two reasons. Firstly, switching a poorly charged second battery into the system loads the voltage at the Smart Start® SBI to below its lower voltage limit, which will cause the Smart Start® SBI to switch back off.

Secondly, voltage drop due to cable length (Smart Start® SBI mounted too far from start battery) can cause the voltage at the start terminal on the Smart Start® SBI to be lower than at the start battery, which can also cause the unit to switch off. Voltage seen by the Smart Start® SBI will now rise again until the Smart Start® SBI switches back on. This switching will continue until the cause of voltage drop is removed. On and Off Time delays are built into the product to avoid the solenoid contacts chattering in this scenario.

### Can I use the Smart Start® SBI to control a load (e.g. fridge) without using an auxiliary battery?

Yes. The voltage monitoring is done on the start battery side of the unit. If a load is connected on the auxiliary side instead of a battery, the unit will still operate when the start battery is charged, providing power to your load.

### Can I use my Smart Start® SBI to winch off both batteries?

Yes. We recommend that the Smart Start® SBI be wired so it automatically connects both batteries when the winch is turned on, through use of the Start Assist feature on the override wire. We also recommend the use of our 200 A Smart Start® SBI for this application.

### Can I use the Smart Start® SBI on a positive chassis vehicle?

Yes. Please contact REDARC for further information.

# SPECIFICATIONS

Part Number	SBI12 (*D)	SBI24 (*D)	SBI212 (*D)	SBI224 (*D)
System Voltage	12V	24V	12V	24V
ON Volts	13.2V	26.4V	13.2V	26.4V
OFF Volts	12.6V	25.4V	12.6V	25.4V
Turn ON Delay	5 sec			
Turn OFF Delay	10 sec			
Max. Cont. Current	100 A		200 A	
Max. Inrush Current	400 A		600 A	
Standby Current	< 5 mA			
Dimensions	75 × 70 × 80 mm (3" × 2.8" × 3.2")		90 × 95 × 100 mm (3.5" × 3.7" × 3.9")	
Weight	200 g (0.4 lb)		600 g (1.3 lb)	
Warranty	2 years			
Standards	CE, C-Tick, AS/NZS CISPR11:2004, UKCA			

\*D indicates Dual Sensing Models.

Voltage tolerance of  $\pm 0.1$  V

## IMPORTER CONTACT INFORMATION

### UK

Ozparts UK Ltd  
1 Prospect Place  
Pride Park  
DE24 8HG, Derby  
UK

### Europe

Ozparts Pl sp. z o.o.  
ul. Slowackiego 32/5  
87-100 Torun  
Poland

### Tech Support

1300 REDARC (1300-733-272)

### Australia

+61 8 8322 4848

### New Zealand

+64 9 222 1024

### UK & Europe

+44 (0)20 3930 8109

### USA

+1 (704) 247-5150

### Canada

+1 (604) 260-5512

### Mexico

+52 (558) 526-2898

[redarcelectronics.com](http://redarcelectronics.com)

THE POWER OF

**REDARC**<sup>®</sup>