

HYPER SPLIT

32-TON VERTICAL/HORIZONTAL LOG SPLITTER



SKU: 33-137

Operator's Manual

(Manual Part Number: 29-094)





A product registration form is included in the back of this booklet. Submit your registration within 2 weeks of purchase date for superior customer service.

Table of Contents

A. Introduction	1
B. Safety Information.....	2-4
C. Safety Decals.....	5-6
D. Controls and Features	7-8
E. Parts Lists	9-12
F. Assembly Guide.....	13-18
G. Operating Guidelines	19-22
H. Routine Maintenance.....	23-24
I. Storage	25-26
J. Troubleshooting	27-28
K. Specifications.....	29
L. Warranty Information	30
M. Registration	31

KEY TO SYMBOLS

	Indicates the possibility of death or serious injury.
	Indicates the possibility of injury to self or damage to equipment.
	Indicates additional information.

B Welcome!

C Thank you for buying a Hyper/Split. We design our products to meet the high demands of
D our industrial and commercial clients, with ease-of-use that's aimed at homeowners and
E do-it-yourselfers. That means that our products are tough enough to meet rigorous industry
F standards, but designed for non-professionals to use, too. We warranty all Hyper/Split
G hardware against manufacturer's defect for 5 years from purchase date, and all hydraulic
H components for 3 years.*

I Register your product today for the best customer-service experience.

J If you have feedback or questions, we want to know!

K **Contact us at: customerservice@tooltuffdirect.com or 720-437-7640**

L * Engine covered by engine manufacturer's warranty. See detailed warranty information below.

M For safety, better performance, and a longer service life with your log splitter, read and understand this manual. We have included information relevant to general use and maintenance that will help you keep your log splitter in serviceable condition and maximize the product's working life. Consider this manual a permanent part of the device, keep it with the device, and include it with the device if you sell it.

Call or email our technical support line if you have any questions about the safe operation of this log splitter: techsupport@tooltuffdirect.com or 720-437-7640

Note: Some illustrations and specifications in this manual may vary in according to the legal requirements of different countries. All content is subject to change without notice by the manufacturer.

For warranty claims, parts replacement, repairs, and technical support, record the following information below:

Model No. _____ Hyper/Split 32-ton log splitter [SKU: 33-137]

Serial No. [See p. 7 for location] _____

Date of Purchase _____

Place of Purchase _____



ENGINEERED TO BE FASTER

Keep this instruction manual for future reference!



Read and understand this operator's manual before operating your log splitter. Keep yourself and others safe by observing all safety information, warnings, and precautions. Retain these instructions for future reference. Refer to this manual regularly and when questions arise.



Failure to follow safety instructions outlined in this manual may result in serious injury or death, damage to the device, and/or damage to property. Like all power equipment, working with a log splitter carries the risk of significant injury and even death. *It is not possible to list all of the risks that are associated with misuse or abuse of this device.* Read and follow all instructions, safety guidelines, and maintenance schedules in this manual.

Use common sense and stay safe!



INTENDED USE

This log splitter is engineered, designed, and built to split logs. **DO NOT** use it for any other purpose than splitting logs. Using the log splitter for any other purpose is unauthorized, will void any warranties or guarantees, and may result in damage to the device and property, personal injury, or even death.



OWNER'S RESPONSIBILITY

- Proper assembly, maintenance, and safe use of the log splitter.
- Adherence to all safety instructions and operator's guidelines.
- Correct assembly: modification prohibited.
- Maintenance of the log splitter according to directions and schedules included in this manual.
- Correct use: Ensure that anyone who uses the log splitter is familiar with all controls and safety precautions.



PERSONAL PROTECTIVE EQUIPMENT



When operating this log splitter it is essential that you wear safety gear, including goggles or safety glasses, steel toed shoes, well fitted gloves (no loose cuffs or drawstrings), and hearing protection.





GENERAL SAFETY PRECAUTIONS



- **NEVER** run a gasoline engine in an enclosed space: You risk death or poisoning by carbon monoxide.
- **NEVER** use your hand to check for a hydraulic fluid leak. If you suspect a leak in the hydraulic system, use a piece of paper, cardboard, or wood to check for escaping fluid.
- **ALWAYS** set up the log splitter on level, even ground before operating. **NEVER** set up or operate log splitter on a slope.
- **DO NOT** wear loose clothing or jewelry when operating the log splitter. Keep hands, feet, hair, and clothing away from moving parts.
- **NEVER** operate the log splitter in or near explosive atmospheres, such as in the presence of flammable liquids, gases, or dust. Power equipment can create sparks which may ignite fine dust or fumes.
- **DO NOT** operate this or any power equipment under the influence of alcohol or drugs.
- **DO NOT** allow anyone to operate the log splitter who has not read this operator's manual unless you provide proper instruction and supervision.
- **NEVER** allow children to play on or around, climb on, or operate the log splitter.
- Before any maintenance, repairs, or adjustments turn engine off, allow to cool, remove spark plug wire from spark plug, and relieve hydraulic system by cycling the valve.
- **NEVER** use a damaged, modified, poorly maintained, or improperly assembled or repaired log splitter.
- **BEWARE** of moving wedge! **NEVER** place any part of your body between the splitting wedge and foot plate or log.
- **DO NOT** operate when others are nearby: Keep all people and pets a minimum of 10 feet away from the work area when operating the log splitter.
- Perform all regular maintenance as described in this manual: ensure all screws, nuts and bolts, and hydraulic fittings are tight.
- **NEVER** leave machine unattended while the engine is running.
- Cut logs as squarely as possible before feeding into log splitter.
- Split one log at a time.

- **ALWAYS** split logs *with* the grain of the wood.
- Turn off engine and allow to cool before fueling.
- **ALWAYS** operate the log splitter in a well lit area; Avoid operating in dim, low-light conditions.
- **ALWAYS** lock the stand in place and chock the tires before operating the log splitter.
- **DO NOT** operate the log splitter on uneven terrain, rough ground, or in wet, slippery, muddy, or icy conditions.

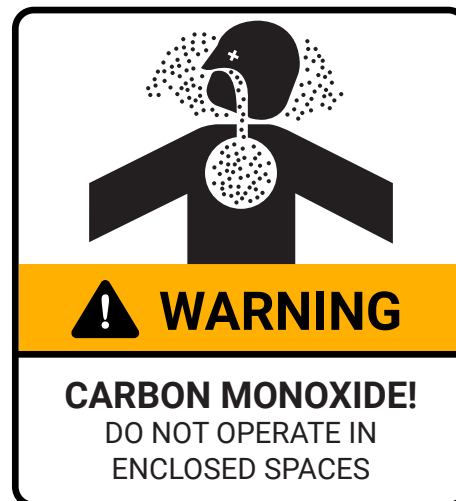



TOWING SAFETY



- Review applicable state and local regulations before towing your log splitter: licensing, lighting, weight, and towing capacity requirements vary by state and by vehicle.
- Before towing, ensure the ball-coupler connection is secure and **ALWAYS** engage the safety chains.
- Before towing, turn the engine's fuel valve to OFF. For longer trips, empty the fuel tank before towing the log splitter.
- Be aware that this log splitter does not have a suspension system. Drive carefully on unpaved or bumpy roads, and avoid excessive speeds.
- Never load cargo onto the log splitter or attempt to use it to transport wood.
- DO NOT allow anyone to sit or ride on the log splitter when it is being towed.
- Disconnect the log splitter from the towing vehicle before operating.
- Consult your vehicle's guidelines about towing capacity and best practices.
- If you have doubts, educate yourself about best towing practices before towing the log splitter!



FIRE PREVENTION



- Turn off engine and allow to cool before fueling.
- **DO NOT** operate the log splitter near open flame or fire.
- Clear logs and wood debris from the work area regularly to prevent sparks from igniting. Keep the area around the muffler clear at all times.
- If fuel or oil is spilled, clean the spill area immediately--**DO NOT** operate near spilled fuel or oil.
- Check that the gas cap and hydraulic-tank cap are securely tightened before starting the engine.
- Keep a class B fire extinguisher on hand when operating the log splitter as a precaution against fuel or oil fires.



This log splitter uses a gas-powered internal combustion engine which may pose a fire risk, especially in natural environments such forest-covered lands or grasslands. It is critical that the engine is fitted with a spark arrester (included with most models) or deflector when operating in these or other fire-prone areas.



Consult federal, state, and local authorities regarding fire codes, regulations, and fire prevention resources.

ATTACHING THE HITCH BALL

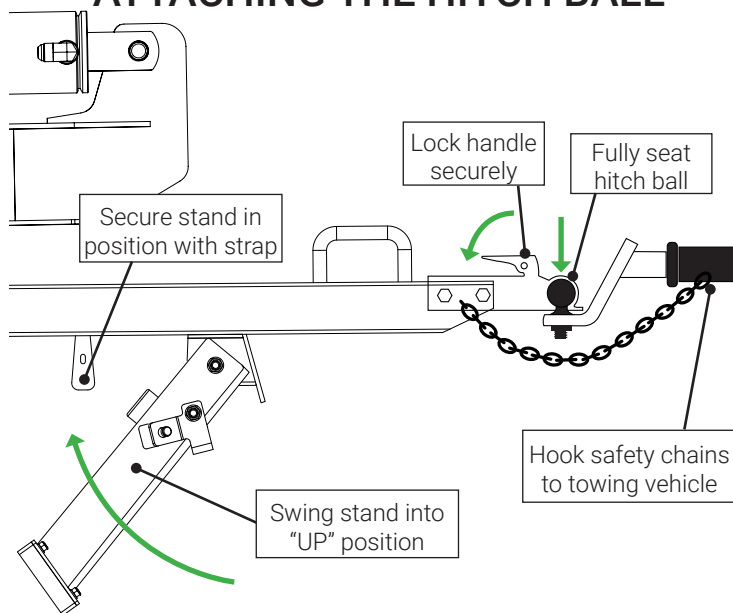

SPARK ARRESTORS / DEFLECTORS

Spark arrestors (included on some models) or deflectors must be removed, inspected, and cleaned every 50 hours of running time.

1. Check that the spark arrester has a clean, serviceable screen. If needed, clean with a soft brush. Replace if damaged. Clean carbon build-up from deflectors.
2. (Re)Install the spark arrester or deflector on the muffler with the screws included.
3. Install arrestors and deflectors so that falling rain and water cannot enter.
4. Don't install an arrester or deflector so that the exhaust points towards the operator.
5. Always set up the log splitter so that the arrester / deflector faces away from any inhabited structure.

Sample spark arrestors

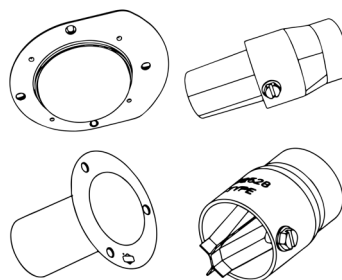

Sample spark deflectors

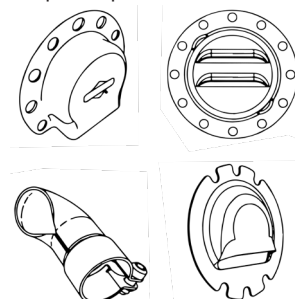



3) SKU: 29-007

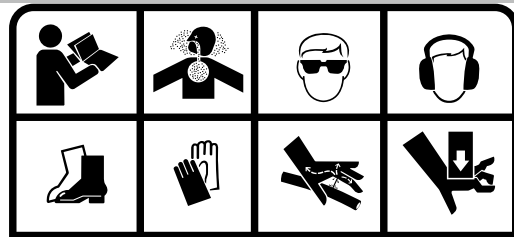

! WARNING

- To minimize the risk to you or others of serious injury or death:
- Read and understand the owner's manual and engine manual before assembling, operating, towing, or servicing the log splitter.
 - Only one person should operate and load logs onto the log splitter. Stay in the manufacturer's designated operator zone.
 - All pets and bystanders should keep away. - Always wear ANSI approved, eye, hearing, foot, and hand protection while operating the log splitter.
 - Never step or reach over the log splitter during operation.
 - Ensure that body, limbs, and clothing are away from moving parts while operating the log splitter.
 - Always grab logs by the sides when loading.
 - Always operate the log splitter outdoors.
 - Never use your hands to check for high pressure oil leaks.
 - Never operate if tired or under the influence of alcohol or drugs.

OPERATING INSTRUCTIONS

1. Ensure that the log splitter is on a stable, flat surface.
2. Start the engine and advance throttle to the maximum.
3. Position log onto the beam up against the foot plate.
Note: Always split wood in the direction of the grain.
4. Move the control handle toward the foot plate to **EXTEND** or **RETRACT** the wedge.

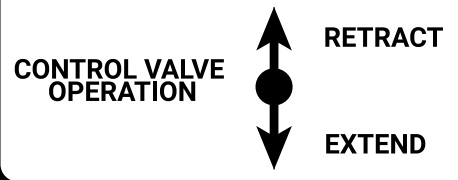

1) SKU: 29-005

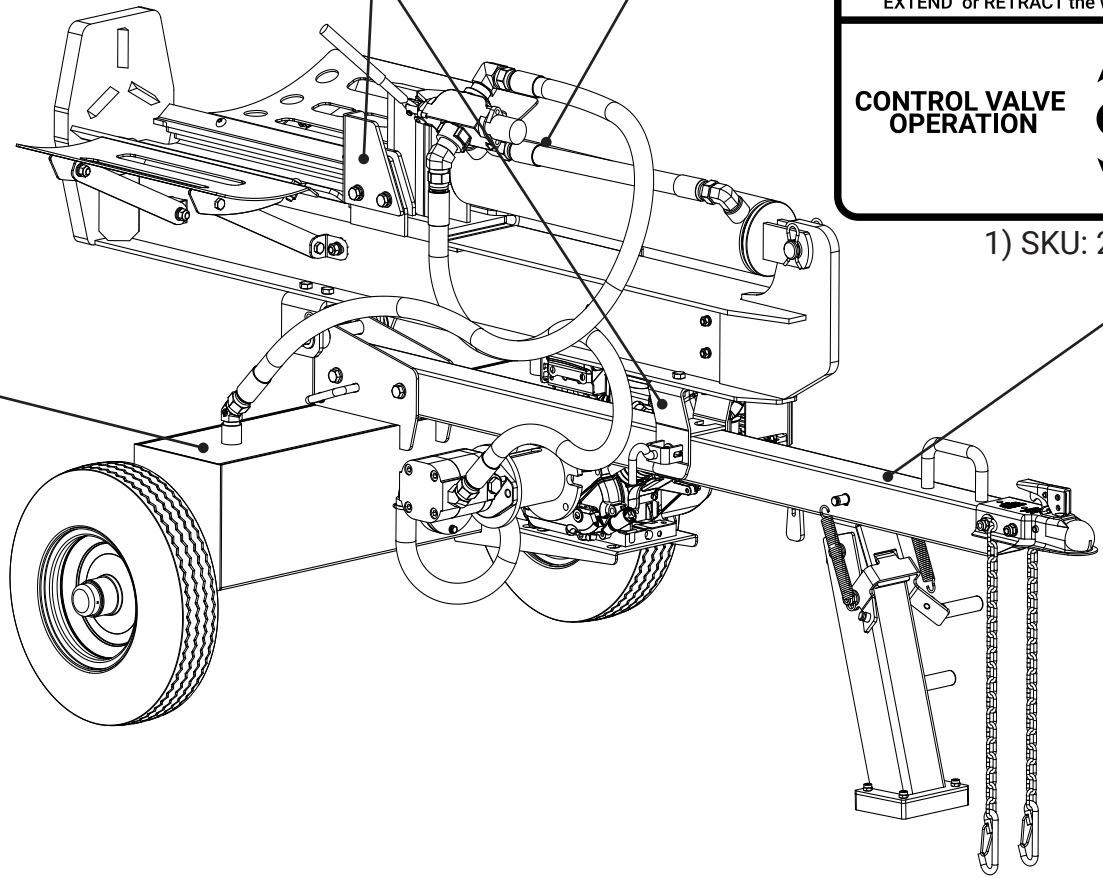

! WARNING ATTENTION

TO AVOID SERIOUS INJURY OR DEATH

- Read the Operation Manual on how to attach the coupler to the hitch ball and how to tow safely.
- Ensure the correct ball size is being used.
- Do not exceed hitch ball or coupler load limits.
- Attach and secure safety chains prior to towing.
- Do not exceed max towing speed of 60 mph.
- Avoid sharp turns and steep angles.
- Check tightness of coupler before towing.
- Replace hitch ball or coupler if damaged.

SKU 29-008

4) 29-008

Parts List

Ref. #	Description	Part # [SKU]
1	Cylinder	31-179
2	9.5hp Kohler CH395 Engine (277cc)	32-012
3	Valve, high flow	31-282
4	Hydraulic pump, 23gpm	31-216
5	Beam assembly, 9"	31-188
6	Hydraulic tank assembly	33-174
7	Tongue assembly, including 2" ball coupler [14] and stand [15]	33-183
8	Wedge, 9"	33-179
9	Wheel assembly, 16" (x2), 1" bearings	33-165
10	Canister, manual and spare parts	24-0014
11	Log catcher assembly (Engine side)	33-150
12	Log catcher assembly (Operator side)	33-151

OVERVIEW

The major components of your Hyper/Split log splitter are listed here for ease of reference. For a detailed breakdown of parts and components, refer to the parts lists in section E.

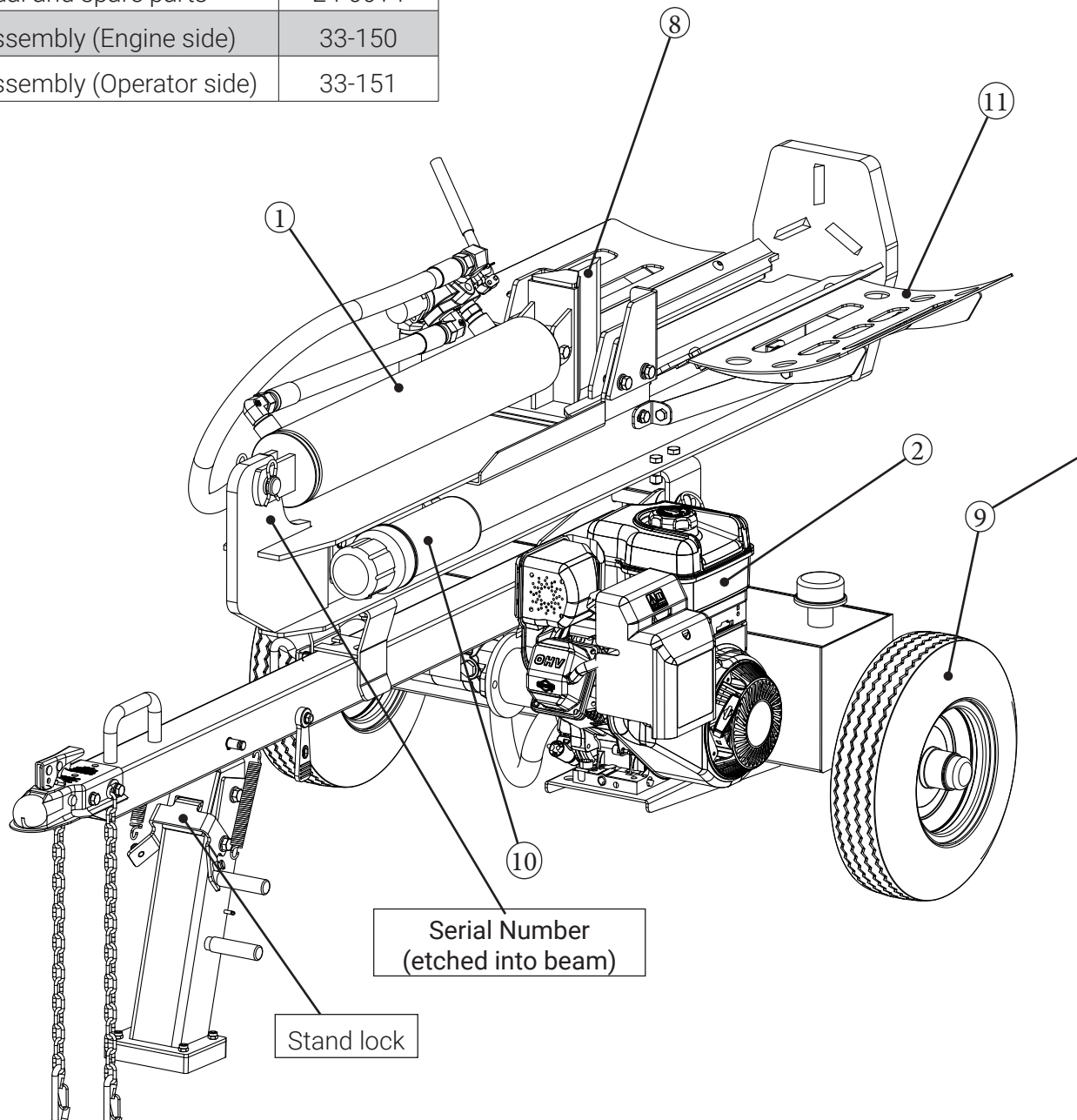

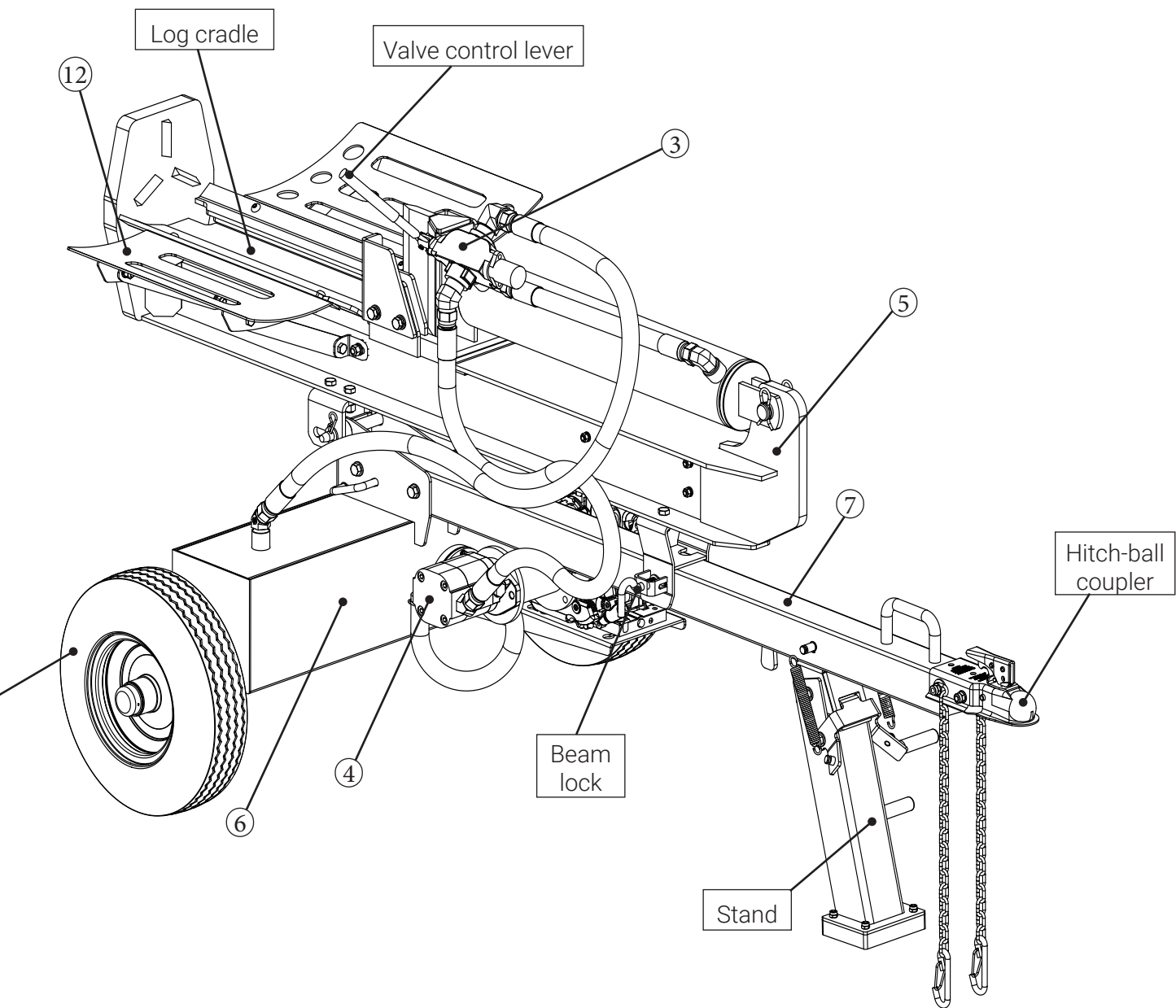

HYPER SPLIT

32-TON

PARTS LIST - BEAM ASSEMBLY

Parts List - Beam Assembly

Ref. #	Description	Part # [SKU]
1	Cylinder, 115 x 560mm, 3/4" NPT ports	31-179
1a	Cylinder pin, 1 1/8" dia. x 3", w/ clips	31-060
3	Valve, high flow	31-282
5	Beam (w/ stripper plates)	33-188
5a	Beam-lock assembly	33-149
5b	Beam pivot bracket, slotted	33-140
5c(R)	Stripper plate - Right	33-148
5c(L)	Stripper plate - Left	33-147
8	Wedge, 9"	33-179

Beam Assembly Hardware *

Description	Part #
Hydraulic fitting, 3/4" NPT male-to-male pipe nipple	31-009
Hydraulic fitting, 3/4" NPT male to 3/4" JIC male, 90° (x 2)	31-086
Hydraulic fitting, 3/4" NPTF male to 3/4" ORFS male, 45°	31-092
Hydraulic fitting, 3/4" NPTF male to 3/4" ORFS male, 90°	31-093
Hydraulic pressure hose, 3/4" x 477mm (length); ORFS	31-189
M12 x 1.75 x 35mm Hex head bolt (x 2)	91280A718
M12 x 1.75 x 90mm Hex head bolt	91280A737
M12 Split-lock washer (x 3)	91202A246
M12 Flat washer (x 3)	98687A114
M12 Hex nut	90591A181

* Replacement hardware and fittings may be obtainable locally

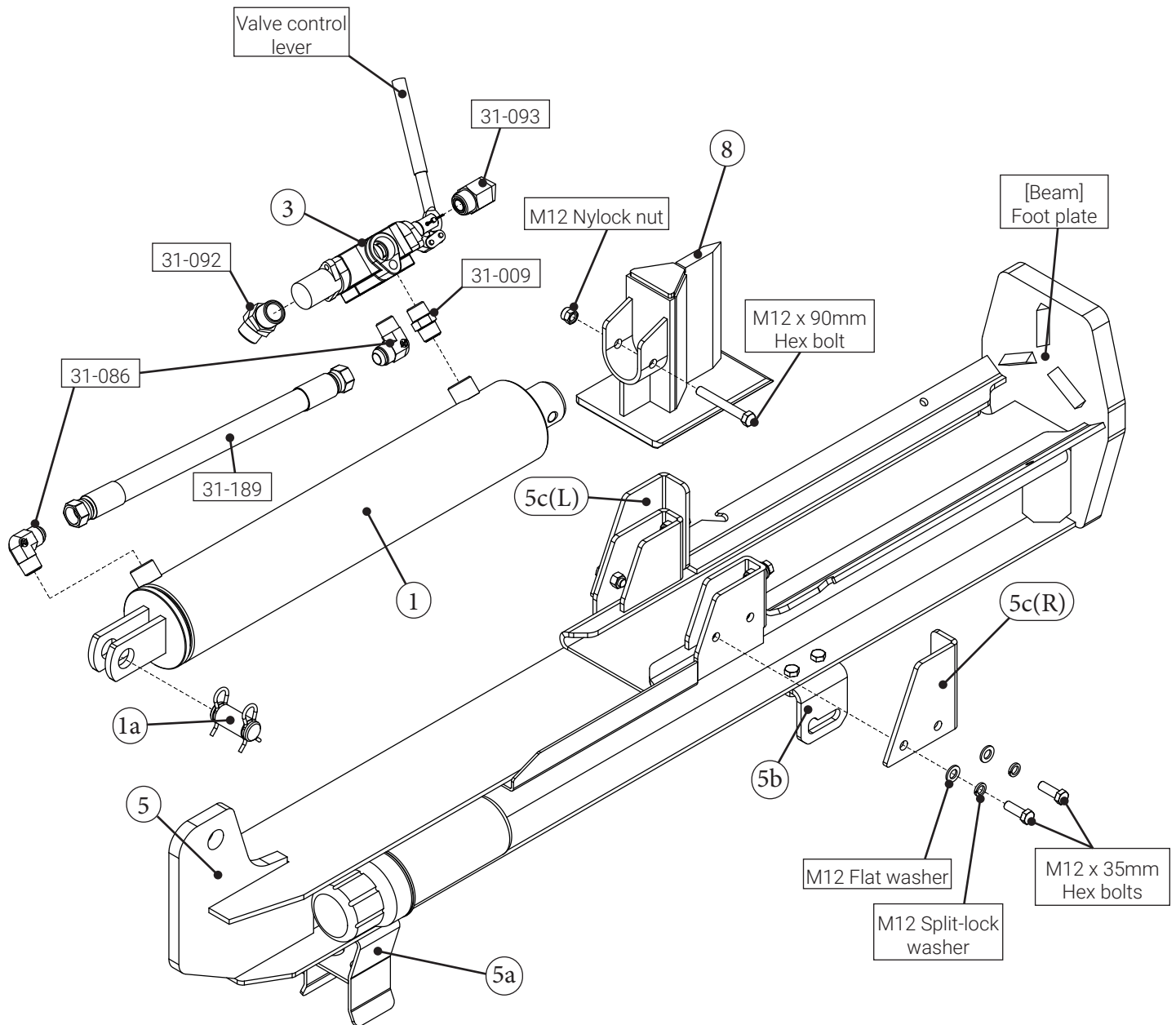

PARTS LIST - HYDRAULIC TANK ASSEMBLY

Parts List - Hydraulic Tank Assembly

Ref. #	Description	Part # [SKU]
6	Hydraulic tank (weldment)	33-212
6a	Vent cap w/ dipstick	28-030
7a	Hydraulic pressure hose, 3/4" x 1550mm; ORFS	31-187
7b	Hydraulic return hose, 3/4" x 1450mm; ORFS	31-190
7c	Worm-gear (hose) clamp (x 2)	31-076
7d	Suction hose, 1" dia.	33-166
9	Wheel, 16" dia. tire, 4.80-8" one-lug rim, 1" bearings (x2)	33-165
9a	Axle, bolt-on (x2)	33-152

Hydraulic Tank Assembly Hardware *

M10 x 1.5 x 55mm Hex head bolt (x4)	91280A295
M10 flat washer (x4)	98687A113
M10 nylock nut (x4)	90576A118
M16 flat washer	91166A310
Hitch pin, 5/8" x 6 1/4"	43-078
R clip	98350A920
Hydraulic fitting, 1" NPT to 1" pipe nipple	31-074
Hydraulic fitting, 3/4" NPT male to 3/4" ORFS male, 45°	31-092

* Replacement hardware and fittings may be obtainable locally

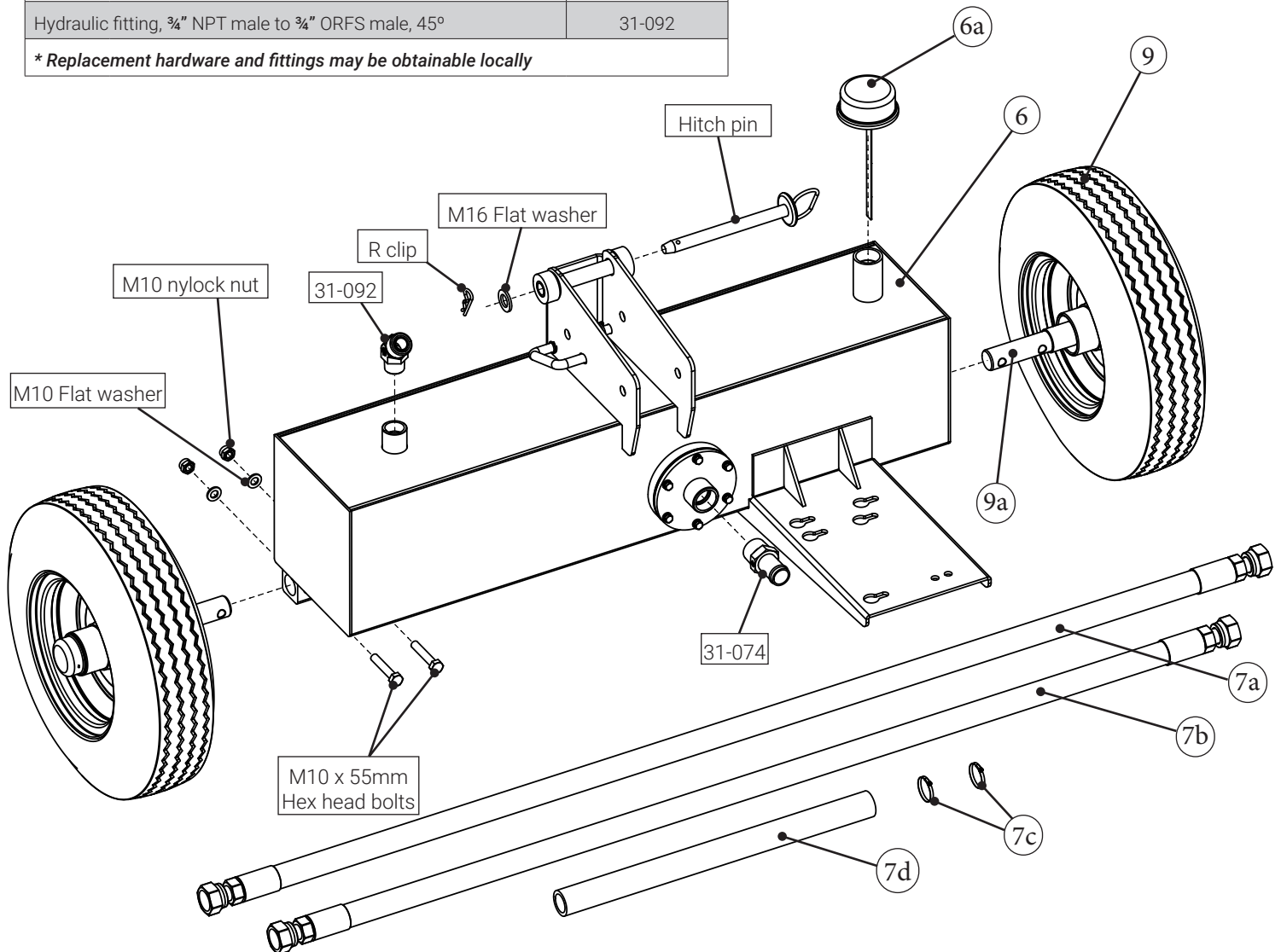

PARTS LIST - TONGUE ASSEMBLY

A
B
C
D
E
F
G
H
I
J
K
L
M

Parts List - Tongue Assembly		
Ref. #	Description	Part # [SKU]
7	Tongue assembly (includes stand, coupler)	33-183
7a	Tongue (weldment only)	33-183-01
7b	2" Ball coupler assembly	21-032
7c	Rubber strap, tongue stand	33-153
15	Heavy duty tongue stand (full assembly)	33-183-03
15a	Stand lock	33-183-04
15b	Rubber foot	33-155
15c	Rubber bumper, tongue stand	33-154
15d	Rubber grip (x 2)	25-026

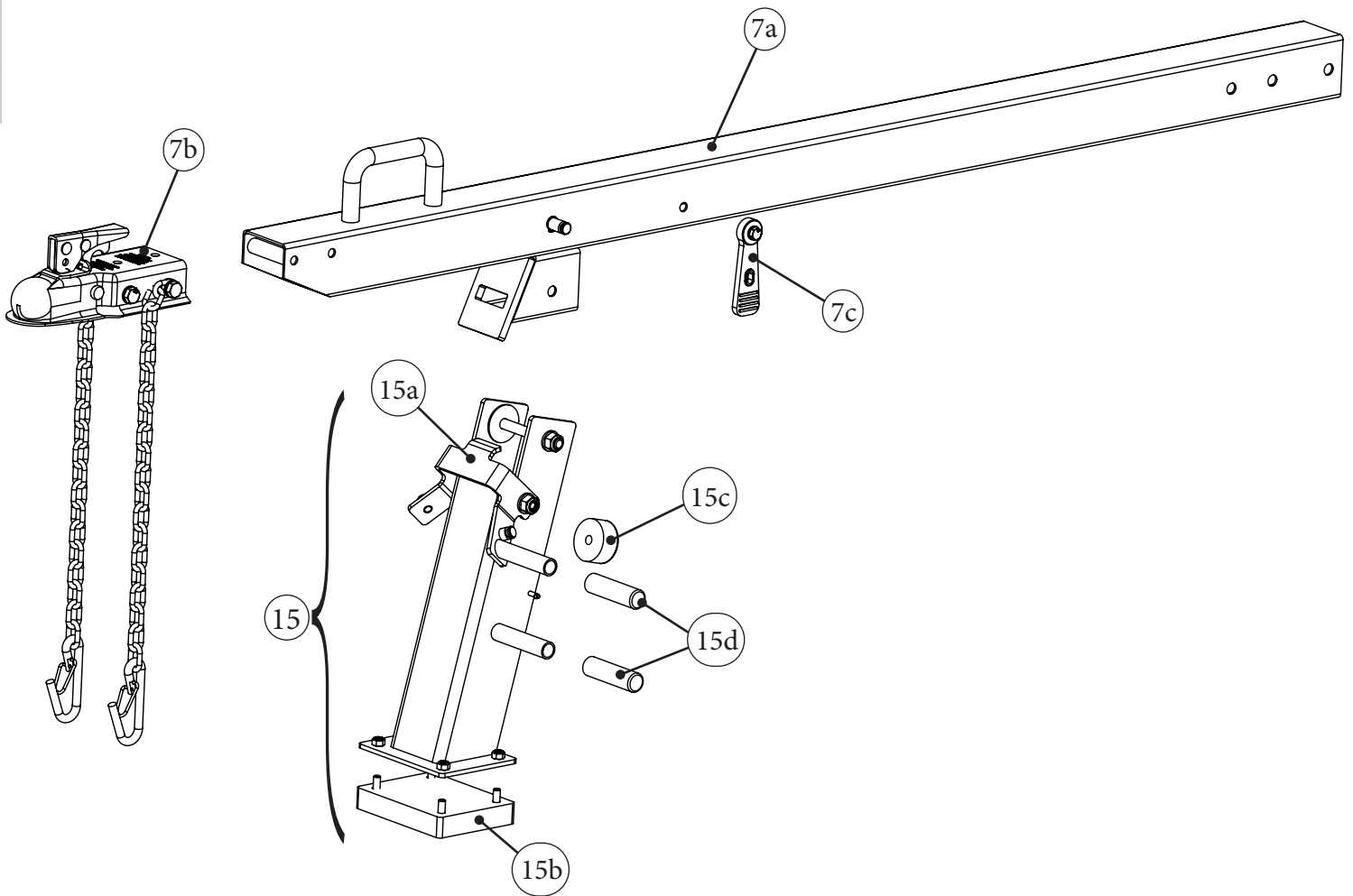

PARTS LIST - ENGINE-TO-PUMP ASSEMBLY

E

Parts List - Engine-to-Pump Assembly		
Ref. #	Description	Part # [SKU]
2	10hp Briggs & Stratton XR1450 Engine (306cc)	32-010
2a	Pump mount, Large	31-273
2b	Steel coupler, 1" ID	31-383
2c	Steel coupler, 5/8" ID	31-387
2d	Engine quick-mount bracket, large (x 3)	33-167
4	Hydraulic pump, 2-stage, 23gpm; 3/4" NPT outlet	31-216

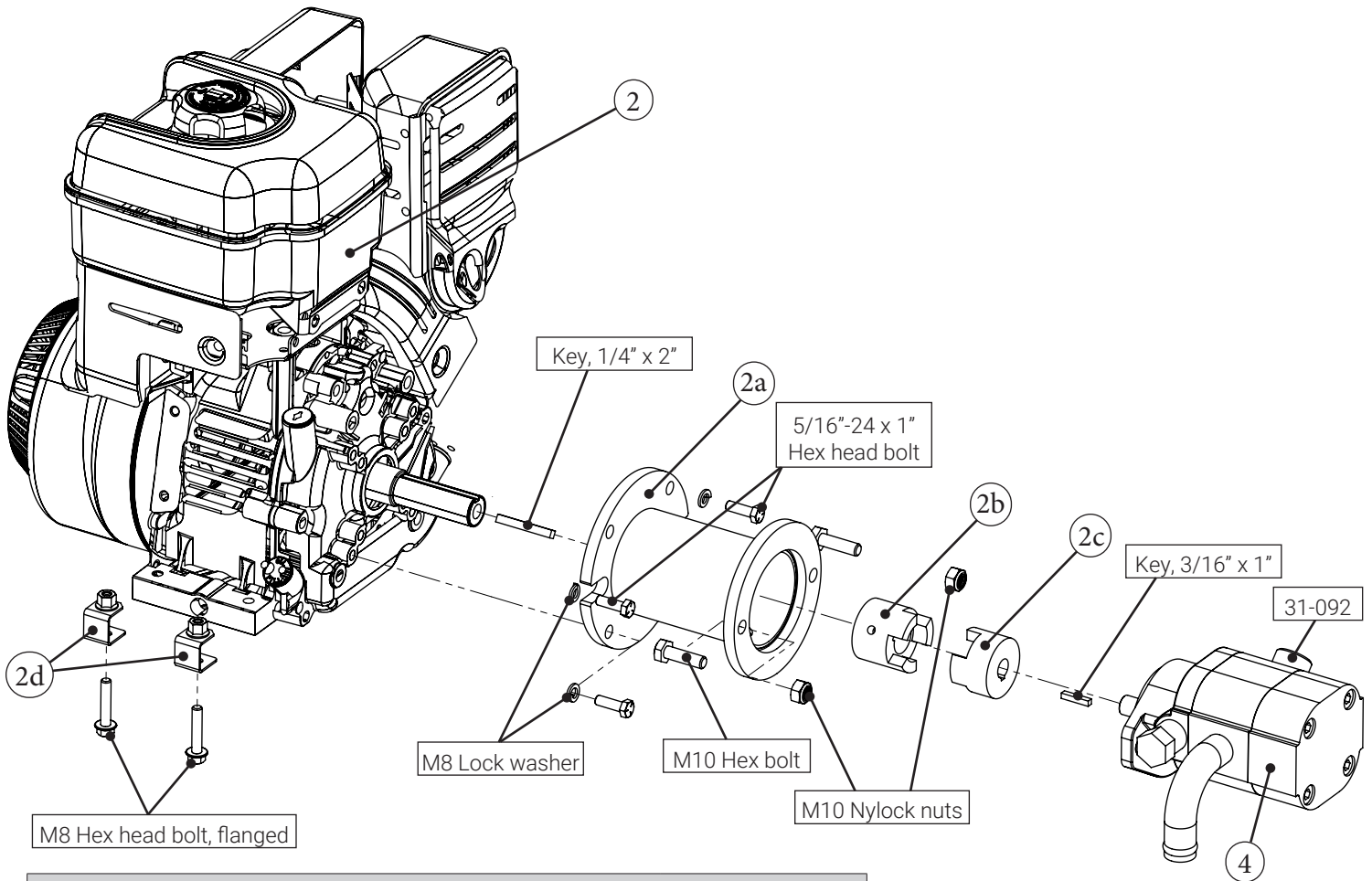

Engine-to-Pump Assembly: Hardware *	
Description	Part #
M10 Nylock nut (x 2)	90576A118
M10 x 1.75 x 35mm Hex head bolt (x 2)	91280A100
M8 Lock washer (x 4)	91202A238
M8 x 1.25 x 40mm Hex head bolt, flanged (x 2)	95735A441
5/16"-24 x 1" Hex head bolt (x 4)	92865A107
Key, 3/16" square x 1"	98870A140
Key, 1/4" square x 2"	98870A245
Hydraulic Fitting, 3/4" NPTF male to 3/4" ORFS male, 45°	31-092
* Replacement hardware obtainable locally	

Tools required:

- Needle-nose pliers
- Box cutter
- #2 Phillips screw driver
- 13mm socket wrench
- 16mm socket wrench
- 18mm socket wrench
- Socket extension
- Socket-wrench driver
- Large adjustable wrench

Step 1: Unpacking the crate

Remove the parts from the crate and prepare them for assembly.



Heavy objects! Lift with care. Team lift: get help when you need it.



Tools needed: 13mm socket with extension and driver.

The beam [5] is bolted (or strapped) down in two locations. Unfasten the beam, and slide out the beam assembly.

1

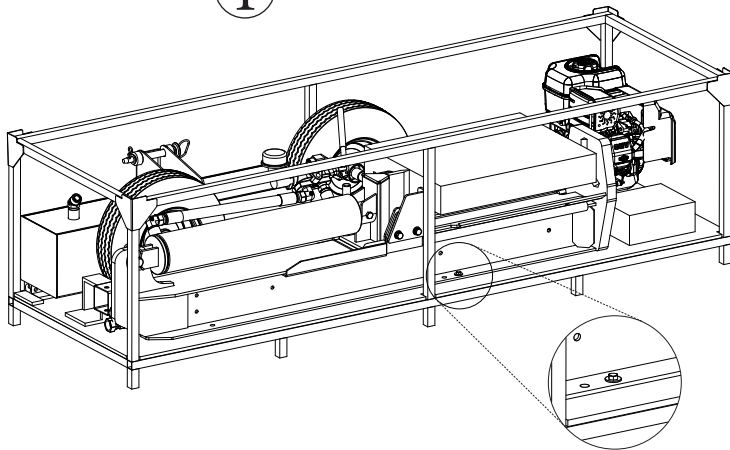

Remove beam [5], wheels [9], and parts kit from crate and set aside. Get help lifting the beam!

Notice: The cylinder [1], valve [3], and wedge [8] come assembled to the beam; this is referred to as the "beam assembly [5]." No further assembly required.

The hydraulic tank assembly [6] is fastened to the crate with a single bolt (or strap). Unfasten and unpack tank assembly.

2

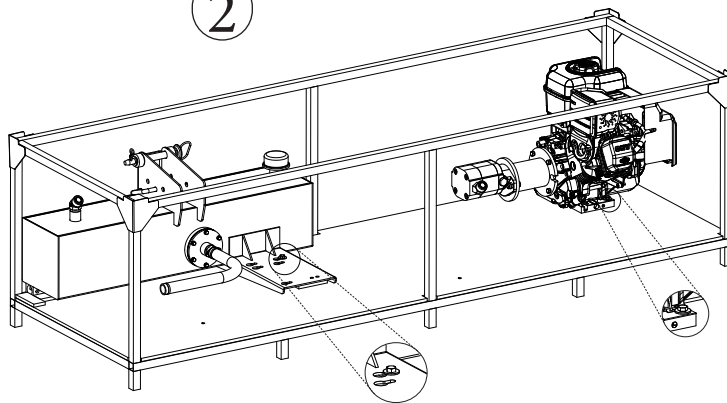

Finally, remove the bolts (or straps) fastening the engine [2], and unpack the engine from the crate.

3

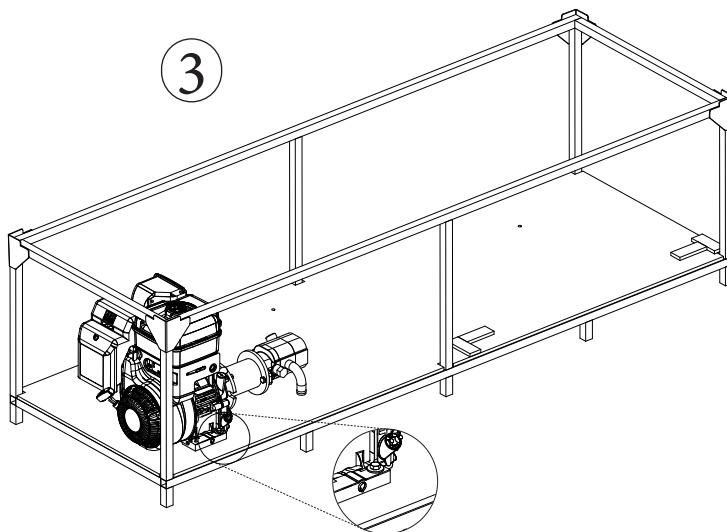

Dispose of the crate at a metal recycling center.

Step 2: Putting on the wheels

Begin the assembly by mounting the wheels [9] onto the hydraulic tank [6].



Tools needed: 16mm socket with driver and an adjustable wrench.

Insert the axle into the weldment and align the holes. Then, insert the M10 x 55mm bolts until they sit flush against the weldment. Finally, mount the flat washers over the bolts, and screw on the nylock nut. Fasten securely. Attach both wheels.

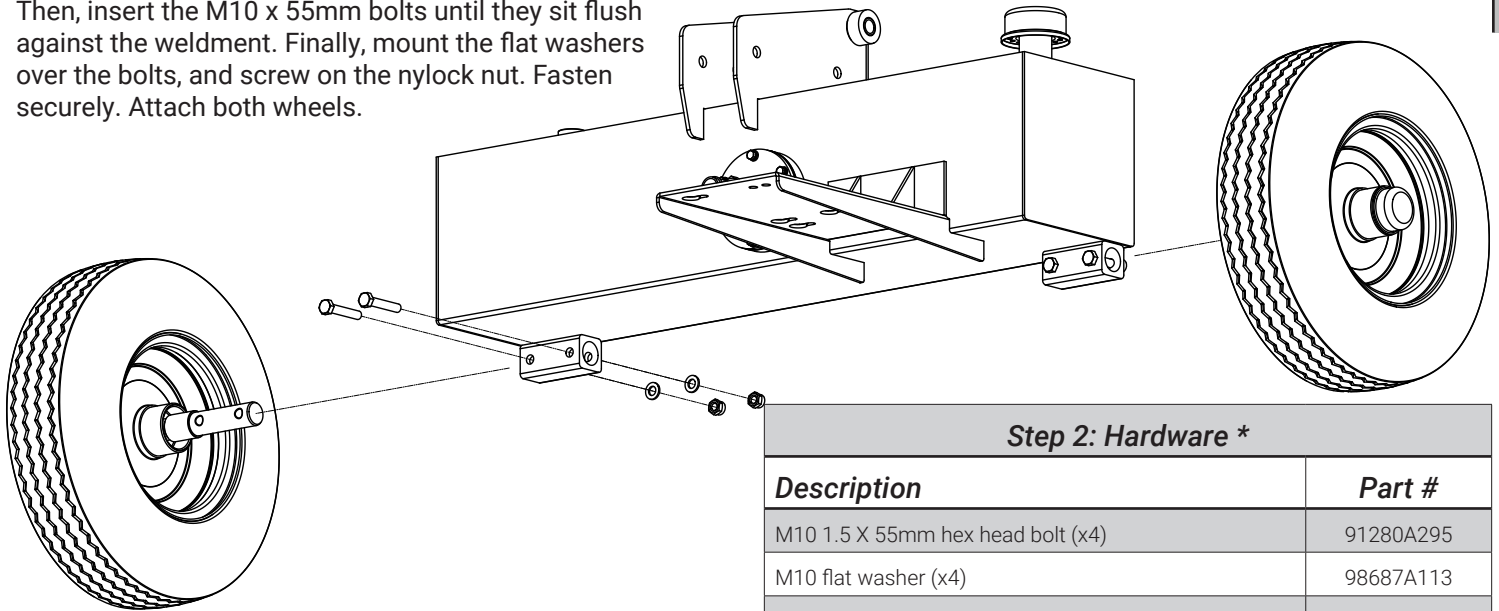

Step 2: Hardware *

Description	Part #
M10 1.5 X 55mm hex head bolt (x4)	91280A295
M10 flat washer (x4)	98687A113
M10 nylock nut (x4)	90576A118
<i>* Replacement hardware obtainable locally</i>	

Step 3: Mounting the tongue

Next, attach the tongue assembly to the hydraulic tank.



Tools needed: 18mm socket with driver and an adjustable wrench.

Slide the tongue between the mounts on the tank. Align the bolt holes and set the 110mm bolts through them one at a time. Set the bolt flush, then mount the flat washers and lock washers and screw on the nut. Fasten securely. Attach both bolts.

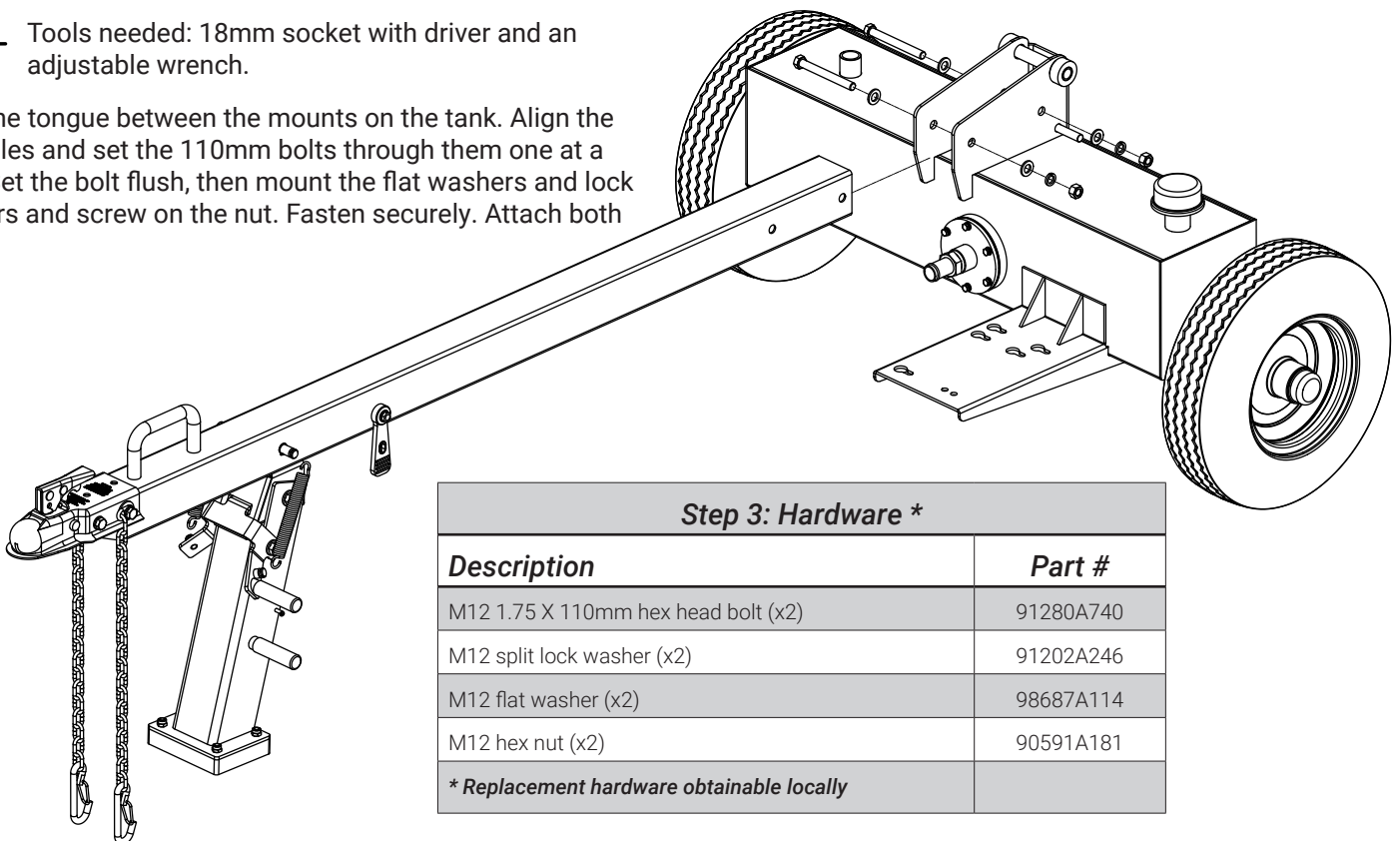

Step 3: Hardware *

Description	Part #
M12 1.75 X 110mm hex head bolt (x2)	91280A740
M12 split lock washer (x2)	91202A246
M12 flat washer (x2)	98687A114
M12 hex nut (x2)	90591A181
<i>* Replacement hardware obtainable locally</i>	

Step 4: Mounting the engine

Once the tongue is attached, put the stand down so that the frame sits level. Now you're ready to attach the engine.



Heavy object! Lift engine with care. Dropping the engine risks significant damage and the possibility of injury! Team lift: get help if you need it.



Tools needed: 13mm socket with driver and adjustable wrench (or 13mm open-ended wrench)

If the quick-mount brackets are not already installed, install them onto the engine's mounting block at the 3 locations shown. Begin threading the M8 flanged bolts into the brackets, leaving a portion of each bolt exposed. Then, lower the engine down onto the mounting plate, seating the bolts in the slots on the engine-mounting plate. Slide the engine into position (see diagram), and tighten the bolts securely.

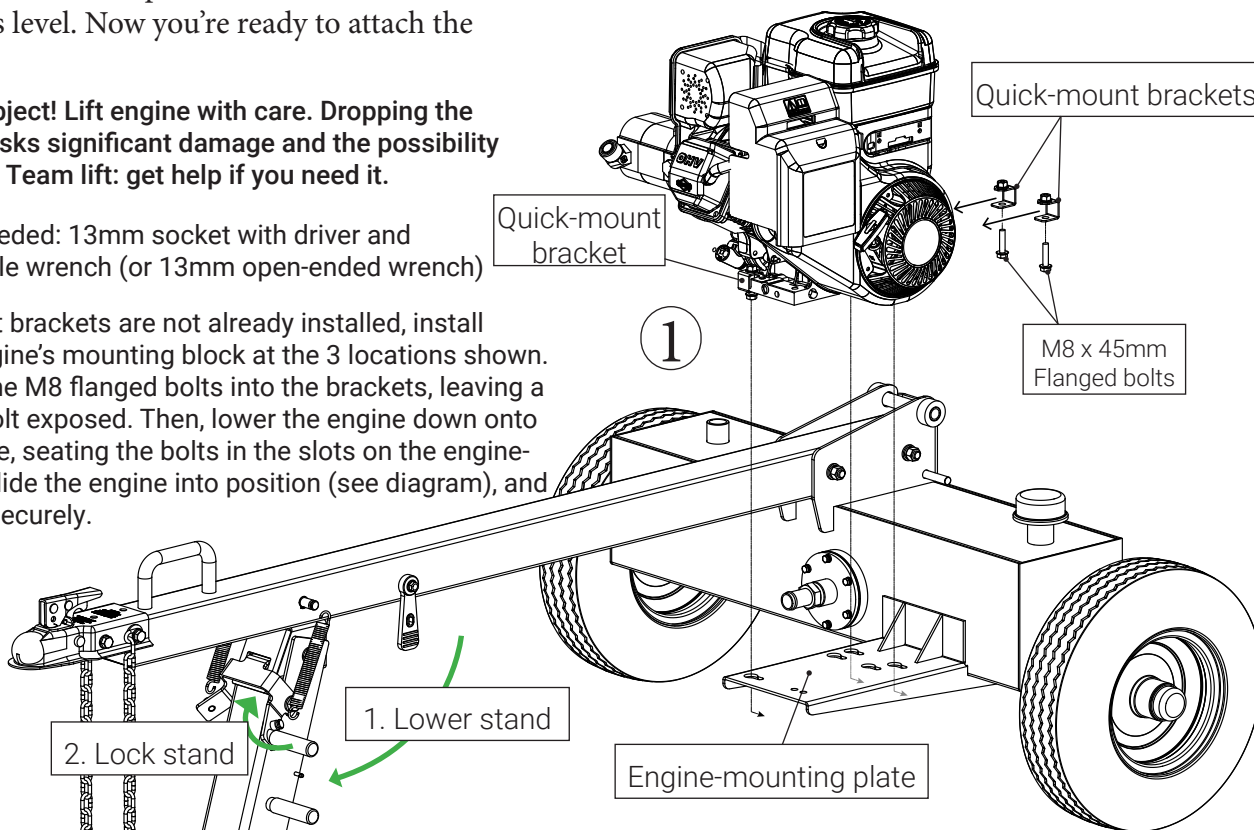

Step 4: Hardware *

Description	Part #
M8 1.25 X 45mm flanged hex head bolt (x4)	95755A445
Quick-mount bracket (x3)	
M8 flat washer (x2)	98687A112
M8 nylock nut (x1)	90576A117
<i>* Replacement hardware obtainable locally</i>	

Secure the engine in position with the stay bolt, as shown. Slide a flat washer between the engine block and the mounting plate before setting the stay bolt through, as shown. Fasten securely.

Note that the final stay bolt does not require a mounting bracket.

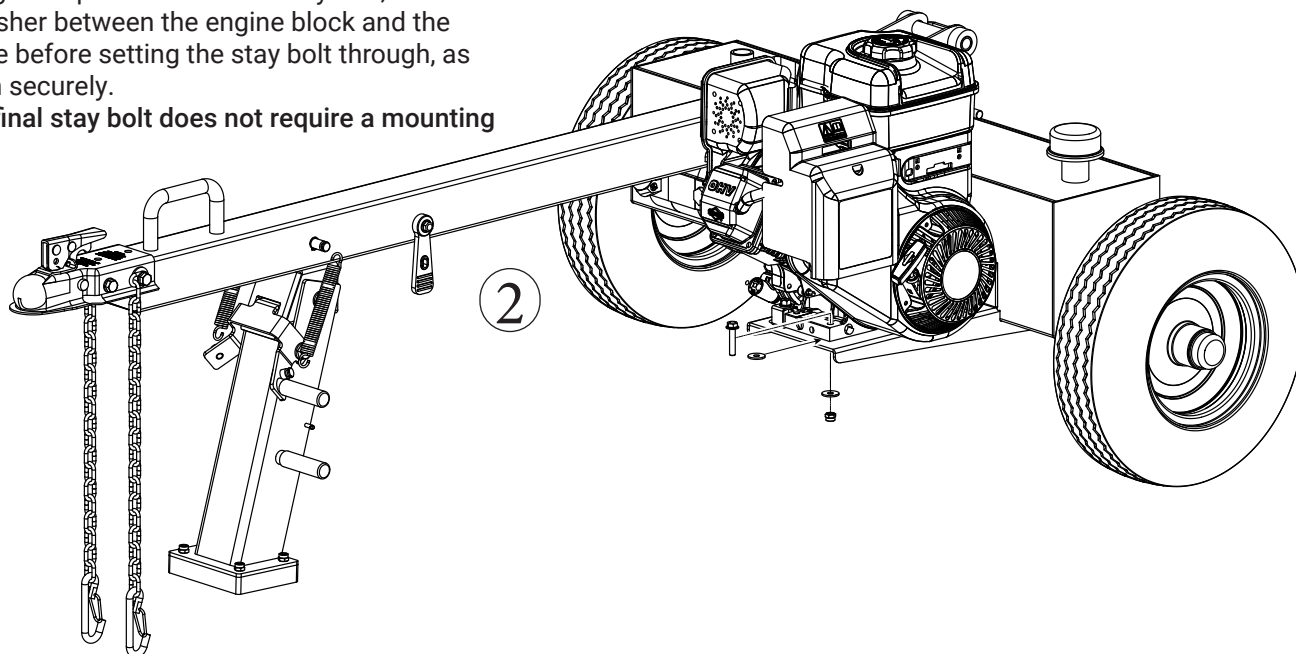

Step 5: Assembling the beam hardware

First stand up the beam [5] on level ground. Once stable, locate the beam lock, pivot bracket, and mounting hardware.



Heavy object! Team lift: get help if you need it.



Tools required: 18mm socket with extension and driver and adjustable wrench

Use the hardware (included) to fasten the brackets onto the beam. Note that the beam-lock assembly [5a] attaches to the top- or cylinder-end of the beam, with the locking mechanism facing the engine (away from the operator). Also note the correct orientation of the pivot bracket in diagram 1 below. Tighten all mounting hardware securely.

Step 5: Hardware *	
Description	Part #
M12 1.75 X 35mm hex head bolt (x6)	91280A718
M12 split lock washer (x6)	91202A246
M12 flat washer (x6)	98687A114
M12 hex nut (x6)	90591A181
M16 Flat washer	91166A310
* Replacement hardware obtainable locally	

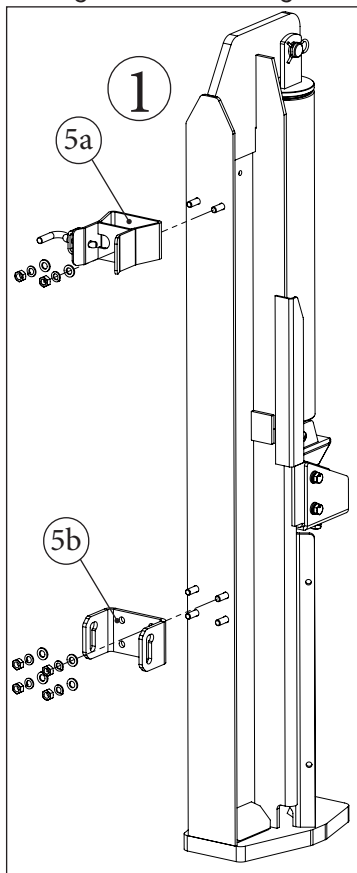

Beam - Parts List		
Ref. #	Description	Part # [SKU]
5a	Beam lock assembly	33-149
5b	Beam pivot bracket, slotted	33-140
5c	Hitch pin	43-078
5d	R-clip pin	98350A920

With the mounting brackets [5a,b] securely attached to the beam [6], roll the frame toward the beam, align the holes, and insert the hitch pin [5c], followed by the M16 flat washer and R-clip pin [5d].

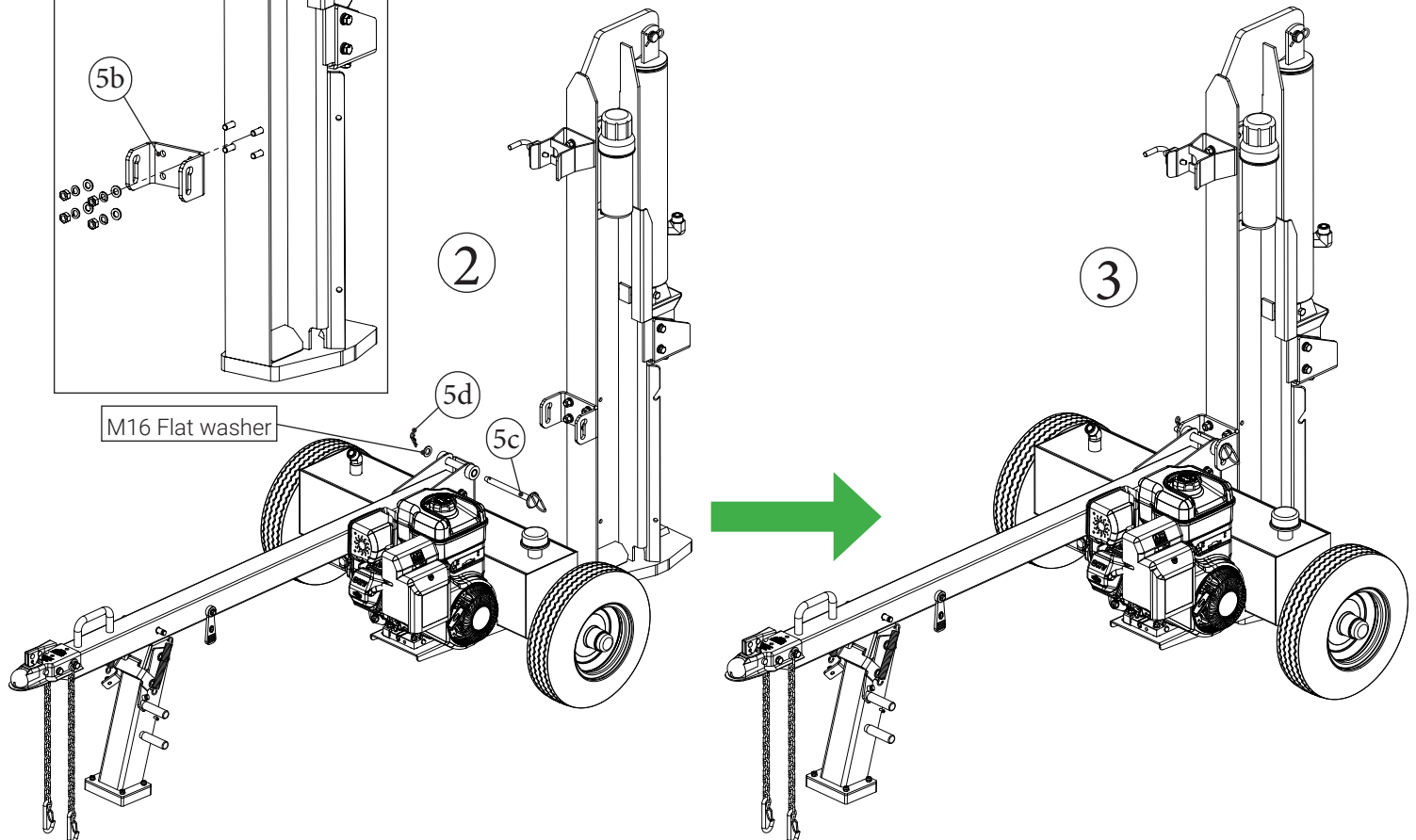

Step 6: Installing the log catchers

The log catchers [12, 13] ship partially assembled. Attach them to the beam [5] and tighten all hardware securely.



Tools required: 16mm socket with driver and 6mm hex drive (Allen) key

While the assembly hardware is still loose, mount the log catchers [12, 13] on the beam [5] using the 30mm button-head bolts. One at a time, set the bolt through, mount the flat washer and lock washer on the bolt, then use the M10 hex nuts to fasten them loosely in place. [See diagram below.] Once the catchers are secured to the beam, fasten the lower support arms: On each side, insert a single 35mm bolt through the first log-catcher support bracket, the beam, then the second support bracket. Attach the mounting hardware loosely, make any final adjustments, then tighten **all** assembly and mounting hardware securely, including the log catcher assembly hardware.

Step 6: Hardware *

Description	Part #
M10 x 1.5 x 30mm Button-head bolt (x4)	91306A786
M10 x 1.5 x 35mm (x2) Hex head bolt	91280A636
M10 x 1.5 x 30mm Hex head bolt (x8)	91280A634
M10 Split lock washer (x14)	91202A242
M10 Flat washer (x14)	91166A280
M10 x 1.5 Hex nut (x14)	90591A171
<i>* Replacement hardware obtainable locally</i>	

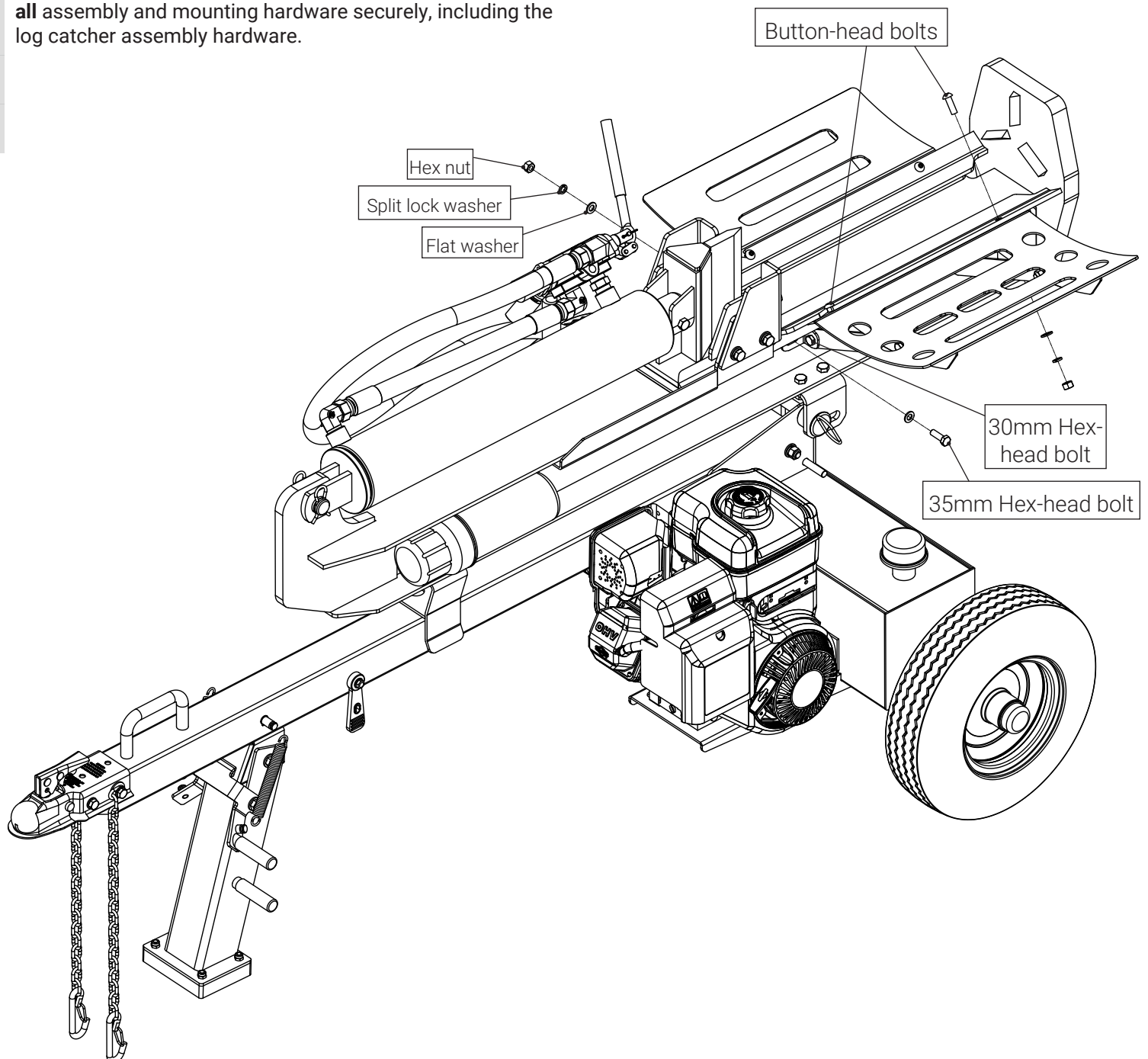

Step 7: Hooking up the hydraulic hoses

Attaching the hydraulic hoses is the last step in assembly. Once the hoses are attached, you're ready to add hydraulic fluid to the system.



Ensure all hydraulic connections are fully seated and firmly tightened. Loose hydraulic fittings pose a serious safety risk once the system is pressurized.

Notice:

For some customers, the retailer will assemble and fill the hydraulic fluid system. In that case, the operator should check the fluid level on the dipstick before starting, and contact the retailer to find out what grade of hydraulic fluid was used to fill the hydraulic tank [6].



Tools required: large adjustable wrench and #2 Phillips screw driver

1. Attach the suction hose [7d] to the outlet port on the hydraulic tank [6]. Tighten the hose clamp securely.
2. Remove cap from pump inlet port, and attach the other end of the suction hose to the hydraulic pump [4]. Again, make sure this connection is tight and secure.
3. Attach the high-pressure hoses. (See below.)

The high-pressure hoses are labeled A & B:

- Hose A [pressure hose; 7a] connects the pump to valve's IN port. (See detailed view below.)
- Hose B [return hose; 7b] connects the valve's OUT port back to the tank. See detailed view below.

The joints (where the high-pressure hoses connect to the fittings) **DO NOT** require pipe thread sealant or tape. JIC, NPSM, and ORFS fitting are designed to operate under very high pressure. Make sure these joints are correctly threaded, completely seated, and securely fastened.

Hydraulics - Parts List		
Ref. #	Description	Part #
7a	Pressure hose, 3/4" ID, ORFS	31-187
7b	Return hose, 3/4" ID, ORFS	31-190
7c	Hose clamp (x2)	31-076
7d	Suction hose	31-188

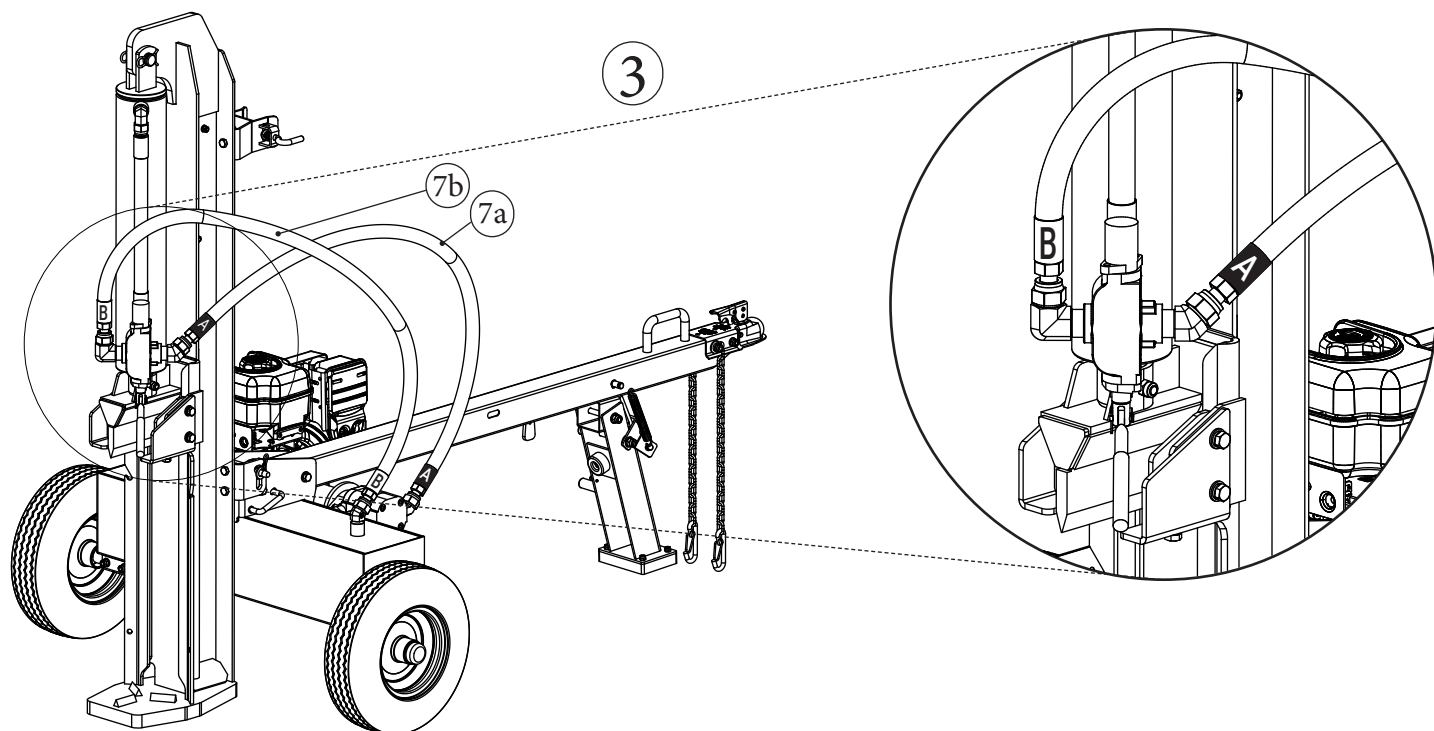
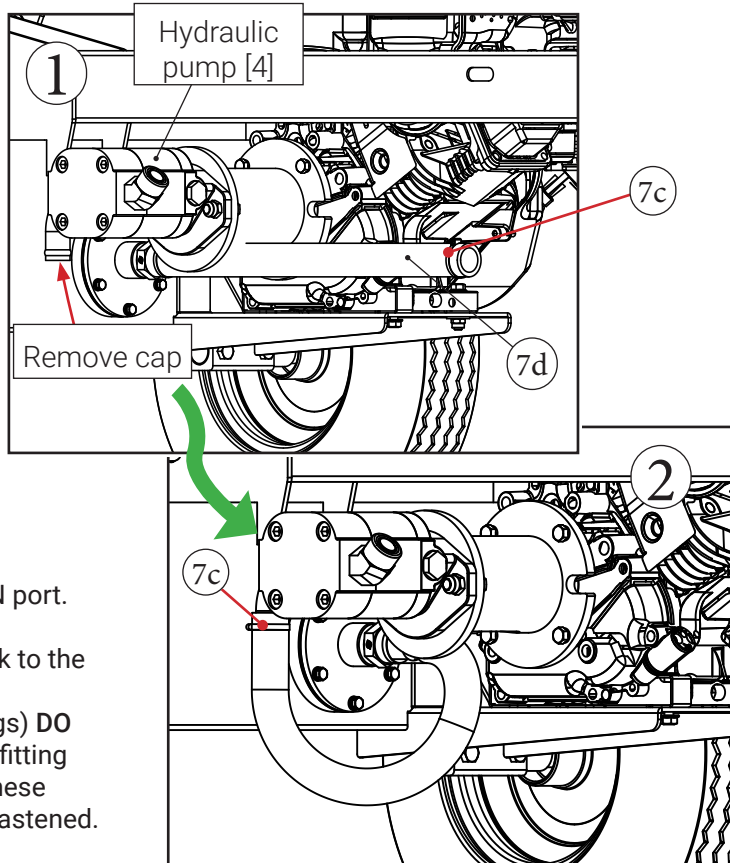

Setting up the log splitter

Getting the log splitter set up and ready to split wood is critical to the safe operation and upkeep of the machine. Follow the guidelines below for best results.



In most cases, using a tow vehicle is the easiest and most economical way to move the log splitter into position.



Always use a tow vehicle when moving the log splitter over rough, uneven, hilly, or sloped terrain. Never set up the log splitter on a slope: you risk roll-over and the possibility of serious injury or death.

Set-up procedure:

1. Find a flat, level space of ground to deploy the log splitter.
2. Clear the ground of debris and tripping hazards.
3. Roll the log splitter into position and chock the tires to prevent unintended movement.
4. Deploy the log splitter in the vertical or horizontal configuration; see diagrams below.



Uncouple the log splitter from the towing vehicle before use.



The operator should stay in the operator zone when splitting wood. The operator has the safest, most efficient access to the control lever and log cradle in these working locations. Operating outside of this area could result in injury or death.

Preparing wood to split

Preparing the logs to be split is critical to the safe operation of the log splitter. Plan ahead and prepare your wood before you start up the log splitter.



22" is the maximum length log that will fit in your HyperSplit log splitter. For best results, prepare the wood by square-cutting the ends before starting the log splitter.



Angle-cut or ragged-ended logs can slide or twist out of position when the wedge makes contact, and may be ejected from the log cradle.

Use a chain saw to cut logs down to a length of 22 inches or less before feeding them into the log splitter.

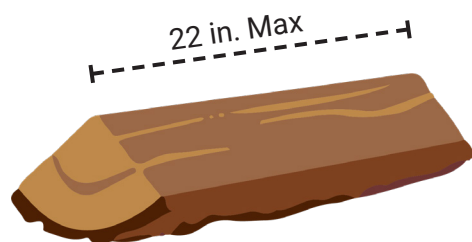

Clear all split logs from the working area immediately.



Never reach across a log splitter when the engine is running, or put any part of your body into the log cradle. Only one person may operate the log splitter at a time.

HORIZONTAL OPERATION

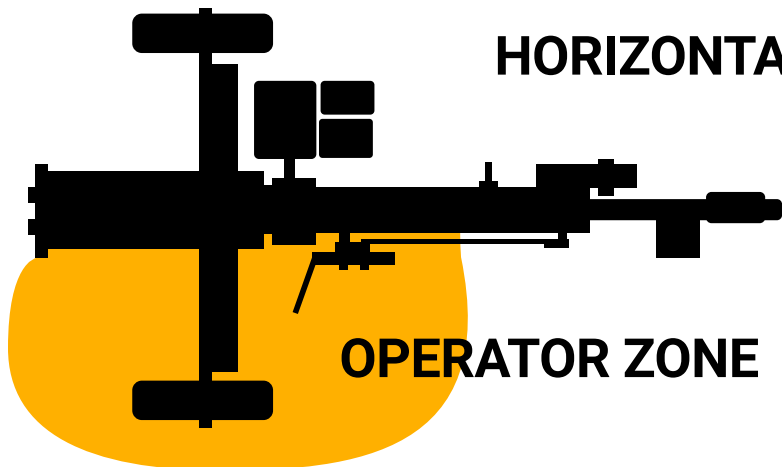

OPERATOR ZONE

VERTICAL OPERATION

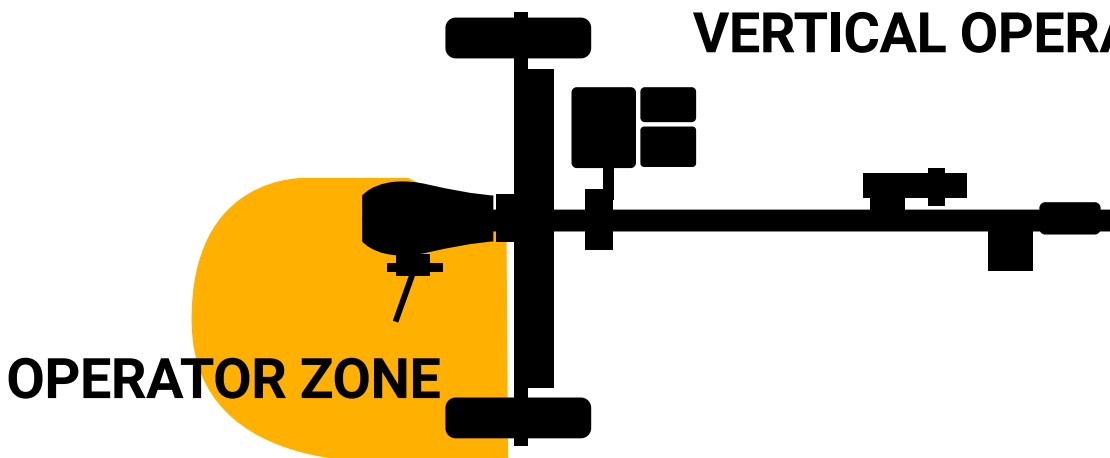

OPERATOR ZONE

Starting the engine

Before you start the engine, review the engine operator's manual for your unit, which is included with the log splitter.

Notice: Failure to follow the operating and maintenance guidelines in the engine's manual may cause premature wear and/or failure of the engine, and may void the warranty

First, check that the engine has an adequate supply of fuel and engine oil, and make sure the air filter is in place and in good condition.



Use fuel with low ethanol content (>10%) or no ethanol. Ethanol can dissolve plastic components such as fuel lines.



Always follow the fueling guidelines in the engine operator's manual. Failure to follow guidelines could result in an explosion, burns, wild fires, destruction of property, or death.

- Don't add fuel to a hot engine: turn it off and allow it to cool.
- Fill the tank in an area with good air flow.
- Don't overfill the fuel tank.
- Check the fuel lines for leaks and cracks.
- Keep your fuel bottle away from open flame, sparks, or other sources of ignition.
- Don't start the engine near spilled fuel.



The operator's manual for your specific engine has detailed information about:

- The engine's features and controls;
 - Fuel and oil requirements;
 - Fueling, starting, and stopping the engine;
 - Maintenance schedules and procedures;
 - Operating and safety decals;
 - Carburetor and engine speed;
 - Servicing the spark plug
 - Servicing the exhaust system;
 - Changing the engine oil;
 - Adding engine oil;
 - Servicing the air filter;
 - Servicing the fuel system;
 - Storing the engine and fuel stabilizers;
 - Troubleshooting;
- and other fun topics.

READ YOUR ENGINE'S MANUAL BEFORE STARTING:

1. Check the condition of the spark plug, muffler, fuel cap, and air cleaner before starting, especially when starting for the first time or if the unit has been in storage.
2. Never crank the engine with the spark plug removed.
3. If you flood the engine, set the choke to RUN (open), move the throttle to FAST, and crank the starter until the engine starts.

Engine-starting procedure:

1. Set the hydraulic valve in neutral position.
2. If the engine is cold, start by setting the choke lever to the closed position. For a warm engine, the choke lever can stay in the open position.
3. Set the fuel-valve lever to ON.
4. Move the throttle lever away from the SLOW position, about 1/3 of the way to the FAST position.
5. Turn the engine switch to the ON position.
6. Pull the starter cord gently until you feel resistance, then pull briskly. Repeat.
7. If the choke is set to the closed position, move it toward the open position by degrees as the engine warms up.
8. Once the engine fires, fully open the choke, and move the throttle to FAST position.

Stopping the engine

To stop the engine in an emergency, simply turn the engine switch to the OFF position.

Under normal conditions:

1. Move the throttle lever to SLOW.
2. Flip the engine switch to the OFF position.
3. Turn the fuel-valve lever to the OFF position.

"Running in" the engine

When first using the engine, fill it with a standard SAE10W-30 blended engine oil (not synthetic). Change the oil after the first 5 hours of running time. After this initial break-in period, you can use a different oil type if desired. See below for more information.



Change the engine oil after the first 5 hours of running time.

About engine oil

We recommend SAE10W-30 engine oil for general use.

Be aware that ambient operating temperatures will impact the viscosity of the engine oil, and certain types of oil will work better in specific conditions. SAE 10W-30, for example, is better in slightly warmer climates; in temperatures below 40° F it may be difficult to start your engine.

Synthetic 5W-30 engine oil works in the widest range of operating conditions, and may be substituted for 10W-30 after the first 5 hours "running-in" period.

If operating in ambient conditions at or above 100° F, synthetic 15W-50 is recommended.

Notice: Used engine (and hydraulic) oil is an environmental hazard if not properly disposed of. Used oil disposal services, such as those at automotive centers, are available in many locations. Disposal services *turn used oil into a valuable resource*: Be a good steward and dispose of your used oil properly.

Splitting wood

In general, splitting wood with a log splitter is a simple process.

1. Set the log in the cradle. Split with the grain, never perpendicular to it.
2. Push the valve control lever forward, towards the foot plate. Continue to extend the wedge until the log is split.
3. If you hit a stubborn knot, you may need to retract the wedge and reposition the log.
4. Pull the valve control lever back toward the cylinder. The auto-return (detent) will return the rod back to the starting position.
5. Load the next log.



Holding handle in the “extend” position at the bottom of the stroke puts unnecessary pressure on the seals and could cause early wear of the seals or cylinder failure, resulting in damage to equipment or injury to the operator.

Auto-return (detent) valve

All Hyper/Split log splitters come with an adjustable detent (auto-return) valve that is factory set to work with the specific components of your splitter. When you pull the lever back to retract the rod, the detent takes over and holds the valve in that position until the rod is completely retracted. The valve then returns to neutral position, relieving pressure on the hydraulic system.

If the auto-return function does not work, or stops working properly, contact customer service for a diagnosis, or visit our on-line support page (link on page 25).

Retracting the stand

To retract the stand:

1. Push down sharply on the stand lock to flip it into the unlocked position.
2. Lift the log splitter using the handle to give the stand room to retract. Set it onto the trailer hitch or other support.
3. Kick or push the stand back toward the retracted “UP” position. Once the stand starts to go, the springs will pull it the rest of the way up.
4. Use the rubber strap to secure the stand in the “UP” position.

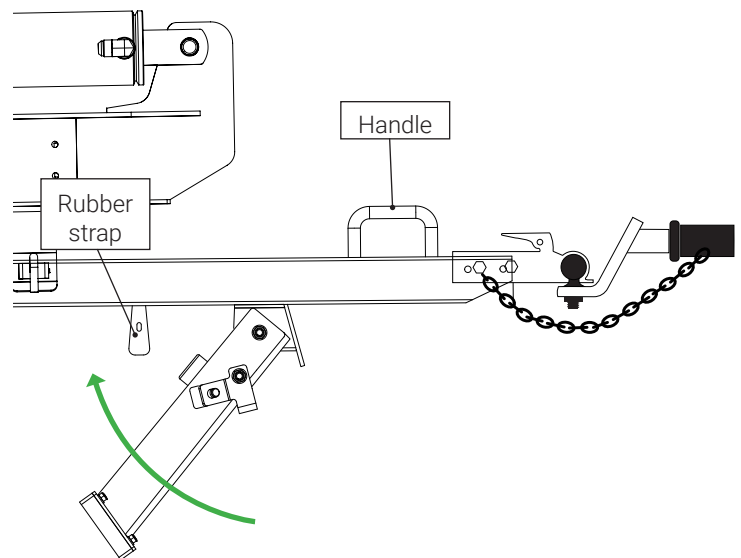
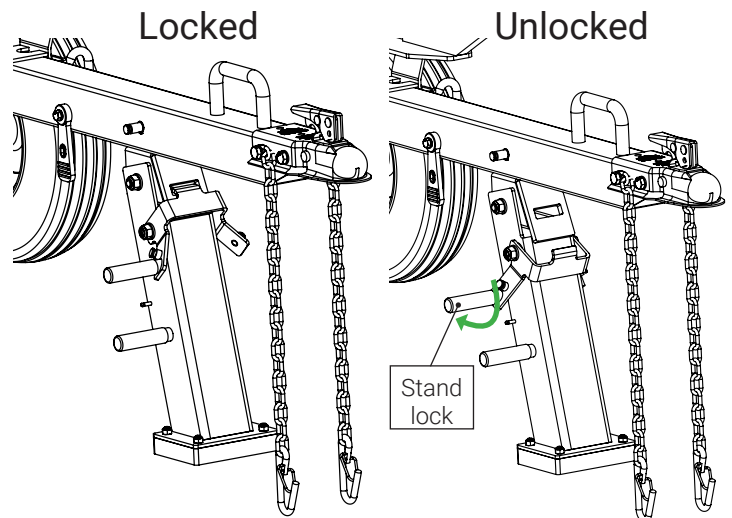

Sharpening the wedge

Periodically inspect the condition of the wedge for sharpness and notches. When needed, sharpen the cutting edge.

Use a coarse metal file to remove any large burrs and reshape divots; finish with a fine metal file to bring a clean cutting edge back to the wedge. If needed, periodically remove the wedge and use a grinder or sharpener service the cutting edge.

Find a local service center to sharpen the cutting edge if you are not comfortable with this process.

Clearing out the log cradle

The wedge [8] runs along guides built into the beam [5]. (The space between these guides is referred to as the log cradle.) The guides may become clogged with wood chips, which can affect the movement of the wedge.

Check the guides for blockage and debris regularly.

- Inspect the wedge guides for trapped debris.
- Wear gloves and get a good implement—a long screwdriver or other tool—to clear wood chips and trapped debris from guides.

Maintaining the air filter

Air intake affects engine performance and longevity. Check the air filter regularly. Clean or replace the filter when dirty.

- Locate the air intake.
- Remove the cover and locate the air filter.
- Clean the air filter by tapping it on a hard surface, or blowing it out with compressed air.
- Foam filters can be gently washed with a solution of warm water and a little dish soap. Wring out gently and allow to dry before reinstalling.
- If filter is damaged during cleaning, replace with a new filter. Do not run your engine without an air filter.
- Replace old, worn out, excessively dirty or damaged air filters.

Inspecting hydraulic lines

Periodically inspect the condition of hydraulic lines. Hydraulic lines are required to handle up to 4000psi of pressure. Damaged lines can be a safety risk (see notice above — pressurized hydraulic fluid), and leaks waste expensive hydraulic fluid.



High-pressure hydraulic fluid can be injected under the skin causing serious injury and even death!

Never use your hand to check for a leak! Replace damaged hydraulic lines immediately.

- Before starting, inspect hoses for cracks and wear.
- While unit is running, inspect hoses and fittings for leaks. If a leak is suspected, use a piece of paper or cardboard to check; never use your hand.
- If leaks are detected, turn off the unit, and cycle the hydraulic system to relieve pressure. Allow unit to cool before attempting any maintenance.
- Replace cracked, worn, or damaged hydraulic lines. If fittings are leaking, remove, clean, and reinstall.

Hydraulic fluid care

- Check the hydraulic fluid level regularly.
- Top off fluid as needed. Never run your log splitter with an insufficient supply of hydraulic oil. If fluid is low, check system for leaks.
- Check the quality of the hydraulic fluid seasonally. Oil should not be dark or cloudy. Contaminated fluid causes damage to the hydraulic components.
- Seasonal changes in ambient temperature and humidity can cause condensed water to accumulate in the hydraulic system, especially during long-term storage. Once hydraulic oil is contaminated with water, it is no longer fit for use. Be prepared to drain and replace your hydraulic oil from time to time.

To drain the hydraulic fluid:

1. Find a suitable collector for used oil.
2. Disconnect the suction hose from pump and empty used oil into collector.
3. To thoroughly drain:
 - Remove the filter-mounting flange to dump any remaining oil.
 - See next section: *Cleaning/replacing the hydraulic suction filter*.
 - Dispose of used oil responsibly.
4. Guidelines for refilling reservoir on p. 19.

Filter Assembly Hardware *

Description	Part #
M6 1.0 X 20mm hex head bolt (x6)	91280A718
M6 split-lock washer (x6)	91202A246
M6 flat washer (x6)	98687A114
Hydraulic fitting, 1" NPT to 1" pipe nipple	31-074

* Replacement hardware obtainable locally

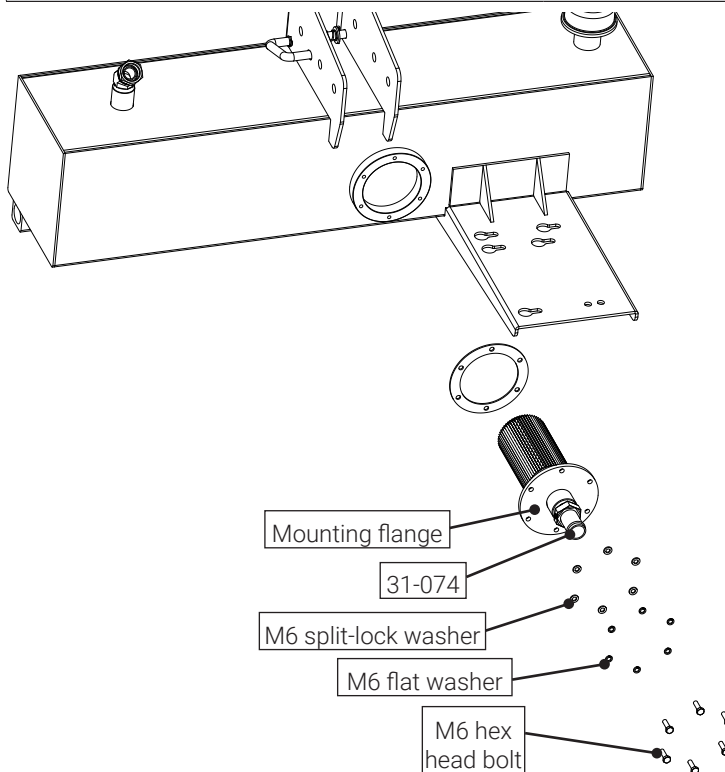

Cleaning / replacing the hydraulic suction filter

When changing the hydraulic fluid, check the hydraulic suction filter/strainer [13] for contamination and degradation. Clean or replace the filter to maintain top performance of your log splitter.



Wear personal protective equipment such as safety glasses and rubber gloves when handling hydraulic oil, and a respirator for chemical solvents.

To access the hydraulic suction filter, first drain the hydraulic reservoir (see above: Hydraulic fluid care), then remove the (6) bolts that hold the mounting flange [13a] in place. Set the bolts and washers aside.

1. Inspect the rubber seal [13b] for wear. Replace if necessary.
2. Examine the filter [13] for wear and contamination:
 - If the filter is dirty but in good condition, clean the filter before refilling the reservoir (see below).
 - If the filter is damaged, replace it before refilling reservoir.
3. Clean the filter thoroughly. There is more than one way to clean a filter; read on for our preferred method. Be gentle while cleaning the filter so as not to damage it.
 - Unscrew the filter from the mounting flange and set upside-down to allow any excess hydraulic oil to drain away.
 - Next, soak the filter in a shallow bath of solvent (ethanol, acetone) or degreaser (e.g.: Simple Green) to loosen up any contamination.
 - Then, blow out the filter with compressed air to remove debris and contamination. Wear your mask!
4. Inspect the tank and replace the filter.
 - This is a good opportunity to inspect your hydraulic tank and remove any sludge.
 - Replace the filter. For the best result, put it back together exactly as originally assembled.

Parts List - Suction Filter Assembly

Ref. #	Description	Part # [SKU]
13	Filter / strainer, hydraulic oil; 1" NPT; 100µm	33-213
13a	Mounting flange, filter	33-215
13b	Rubber gasket	33-216

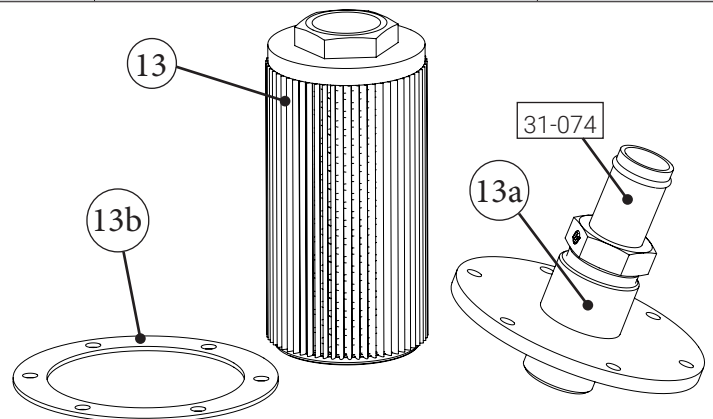

SHORT-TERM STORAGE

When storing your log splitter for less than a month:

1. Retract the rod.
2. Turn off the engine and allow to cool.
3. Clean off the log splitter with a damp cloth.
4. Cover the log splitter or move it to a location where it will not be exposed to the elements.

LONG-TERM STORAGE

Condensed water can build up in the fuel system during extended storage which causes rust contamination, low power output, and shortened engine life.

For long-term storage, the best practice is to drain the gas tank and purge the carburetor. Another option is to add fuel stabilizer to the gas tank, then purge the carburetor.

Draining the gas tank

To drain the fuel from the engine:

1. Open the fuel-shutoff valve.
2. Locate the carburetor bowl. (You may need to review the engine operator's manual.)
3. Find a suitable fuel container and place it below the carburetor bowl to collect the fuel.
4. Remove the drain screw on the side of the carburetor bowl and allow the fuel to drain out completely.
5. Once fuel has drained from the system, replace the screw.

Adding fuel stabilizer

To add fuel stabilizer to the system:

1. Purchase fuel stabilizer that is suitable for high-octane gasoline. Review the instructions on the fuel-stabilizer bottle before continuing.
2. Add fuel stabilizer to the gas tank according the approximate volume of fuel in the tank.
3. Replace the fuel cap and run the engine for a few minutes to allow the treated fuel to make its way through the fuel system.

Purging the carburetor

To purge fuel from the carburetor:

1. Start the engine and then close the fuel valve. Allow engine to run until it stops from fuel starvation. (This may take several minutes.)
2. Allow to cool for 5 minutes.
3. Remove the spark plug and pour a couple of teaspoons of oil into the cylinder.
4. Replace the spark plug.

The engine is now ready for storage.

Wipe down and cover

For long-term storage, protect the log splitter from dust, water, and the elements.

- Drain the gas tank and purge the carburetor.
- Retract the rod to protect from corrosion.
- With a damp rag, wipe down the log splitter to remove built up dust and debris.
- Clean out any wood chips and blockage from the log cradle.
- Remove, clean, and replace the air filter. Order new air and oil filters for next season.
- Wipe down the beam [5], wedge [8], and tank [6] with an oily rag to protect from rust.
- Touch up any scratches or dings with a rust-resistant touch-up paint.
- Cover completely with a tarp to avoid dust build up and water collection.
- For best results, move the log splitter to a location where it will not be exposed to the elements.

Touch-up paint

Log splitters operate in tough conditions. When nicks, dings, and scratches happen, the best thing to do is hit them with some touch-up paint to avoid rust.

- Obtain some rust-resistant touch-up paint and do a little touch up whenever you need to, or before storing the log splitter for the season.

TROUBLESHOOTING

A
B
C
D
E
F
G
H
I
J
K
L
M

Problem	Possible cause	Solution
Engine does not start	Engine switch in "OFF" position; Engine fuel shut-off valve closed	Set switch in "ON" position. Open fuel valve
	Engine is out of fuel	Add fuel (High octane, low ethanol)
	Unit under load during start-up	Cycle valve handle (move back and forth) to remove load; set valve to neutral position
	Faulty spark plug; spark plug disconnected	Check the spark plug
Engine starts but runs roughly	Oil level is low	Add oil
	Choke in wrong position	Adjust choke
	Spark plug wire loose	Attach spark-plug wire securely
Engine stops suddenly during operation	Engine is out of fuel	Add fuel
	Oil level is low - oil sensor may shutoff engine	Fill crank case to level indicated; Set up log splitter on a flat, level surface
	Valve bypass pressure set too high	Adjust valve bypass setting
Engine power level low; Engine overheats	Insufficient air intake	Check air filter; if needed clean or replace air filter. Check for blockage in air intake system.
Engine runs as if under load	Faulty pump or valve (causing fluid obstruction in hydraulic system)	Check individual components
Ram/wedge moves slowly or unevenly	Air in the hydraulic system	Purge air by extending and retracting the wedge several times without load until the motion is smooth
	Debris lodged in beam guides	Clear debris from beam
	Low hydraulic fluid	Check oil level; add oil as needed
	Pump stuck in 2nd stage	Contact customer service
Oil leaking from fittings or hoses	Loose hydraulic fitting	Inspect fitting and install correctly
	Faulty O-ring	Check O-ring fittings, Replace faulty or missing O-rings
Oil leaking from front of cylinder	Faulty cylinder seals	Recondition cylinder
	Scored or bent cylinder rod	Contact customer service
Wedge will not extend or retract	Control valve is faulty	Contact customer service
	Hydraulic pump is faulty	Contact customer service
	Low hydraulic oil	Check oil level; add oil as needed
	Hydraulic cylinder is faulty	Replace cylinder seals
Wedge extends and retracts but will not build pressure to split wood	Faulty cylinder seal; Key has fallen out of pump or engine	Check drive keys in pump and engine; recondition cylinder
Wedge does not auto-return	Low hydraulic fluid	Check oil level; add oil as needed
	Faulty control valve	Contact customer service

Before performing any maintenance turn off unit and allow to cool, cycle hydraulic system several times to relieve pressure, turn engine switch and fuel shut-off valve to "OFF" position, and disconnect spark-plug wire.

TROUBLESHOOTING, CONTINUED

Problem	Possible cause	Solution
Wedge extends but will not return	Faulty cylinder	Contact customer service
Excessive bouncing while towing	Tires under-inflated	Inflate tires to pressure indicated on sidewalls

Before performing any maintenance turn off unit and allow to cool, cycle hydraulic system several times to relieve pressure, turn engine switch and fuel shut-off valve to "OFF" position, and disconnect spark-plug wire.

HYPER ⚡ SPLIT

Scan the QR code to visit our log splitter support page for up-to-date maintenance and troubleshooting information and videos.



For instructions on using this QR code, see "Warranty Registration by Online Submission" on page 31

Questions? For service call or e-mail:
720-437-7640
customerservice@tooltuffdirect.com
techsupport@tooltuffdirect.com

SPECIFICATIONS

Hyper/Split 32-ton Spec Sheet

Feature	Rating or Capacity
Maximum splitting force	32 tons
Cycle time	6 seconds
Wedge height	9 inches
Hydraulic pump	23gpm, 2-stage gear pump
Hydraulic oil	AW-32, -46, or -68 hydraulic oil
Hydraulic fluid operational capacity	8 gallons
Maximum log length	22 inches
Hydraulic cylinder	4½" (115mm) diameter
Maximum pressure	4000 psi
Wheel size	4.80 x 8" one-lug rim with 16" tire and 1" bearing
Hitch type	2" ball coupler
Engine	9.5hp Kohler CH395 (277cc)
<i>* Review engine manual for specifications and care instructions.</i>	

Questions? For service call or e-mail:
720-437-7640
customerservice@tooltuffdirect.com
techsupport@tooltuffdirect.com

WARRANTY INFORMATION

ToolTuff Direct, LLC, offers a limited warranty against defects in manufacturing and workmanship of all major components [see diagram on page 7] for your Hyper/Split log splitter. The warranty is extended to the original purchaser only, and covers residential users only: commercial users are not covered under the warranty. The warranty covers hardware components for 5 years from date of purchase and hydraulic components for 3 years. (The engine is covered separately by the engine manufacturer's warranty; see engine operator's manual.) This warranty gives the consumer certain and specific rights which may vary from state to state.

Warranty claims may be refused if registration is not completed or date of purchase cannot be established. ToolTuff may require photographic or other evidence for the evaluation of your warranty claim. Register your product upon purchase for the best customer service experience.

The warranty does not cover normal wear, misuse, neglect, abuse, improper maintenance, overload beyond rated capacity, accidents, cosmetic defects, consumables, non-authorized replacement parts or accessories, operation with inadequate supply of oil (engine or hydraulic), improper fluid types, or unauthorized adjustments.

Important Notice

We, the manufacturer, reserve the right to change the product and/or specifications in this manual without notification. The manual is for informational use only; any pictures, drawings, or graphics depicted herein are for reference only.

Warranty Repair and Service

Do not return this product to the store for warranty issues or repair. For assistance, call our customer service department at 720-437-7640. If needed, we will work with you to locate the nearest participating service center.

Acceptance of responsibility:

I (the purchaser) have read the Operator's Manual or someone has read and explained it to me. I understand the limited warranty does not cover any labor, and I agree that all disputes will be settled by binding arbitration. I understand that improper maintenance or modification of the device will void the warranty. The mark next to each item below confirms my acceptance of responsibility for the use and maintenance of the log splitter. I understand that I alone am responsible for the proper maintenance, care, and safe operation of this log splitter. I acknowledge that I:

- Received, read, and understand this Operator's Manual;
- Understand the safety warnings;
- Reviewed the specifications section;
- Understand the maintenance requirements.

I (the purchaser) understand that persons who have not read and understood the operator's manual shall not be allowed to use the device. Children shall not operate or be near the equipment during operation. Anyone operating the log splitter shall first read the general safety and use guidelines in this manual.

Is this log splitter used by a business?

- Yes, business type: _____
- No

Owner / Purchaser Signature: _____

HYPER SPLIT

WARRANTY REGISTRATION BY E-MAIL

Warranty registration may be completed by filling out the form above, taking a picture or scan of the form *and* your proof of purchase, and emailing them to: warranty@tooltuffdirect.com

In the subject line of the warranty registration e-mail, please write: Hyper/Split

WARRANTY REGISTRATION BY ONLINE SUBMISSION

Registration may be completed by following the QR code below. Use the camera app on your smartphone in the same manner you would if you were taking a photo. Your smartphone will recognize the code, and a link will appear on the screen. Tap the link and you will be directed to the form on our website.



WARRANTY REGISTRATION BY MAIL

To register your device:

1. Fill in the form below,
2. Cut out the form, attach a copy of the receipt or proof of purchase, and
3. Mail to:

ToolTuff Direct
 15000 West 44th Ave, Suite B
 Golden, CO 80403

WARRANTY REGISTRATION FORM
HYPER/SPLIT 32-TON [RED] LOG SPLITTER

Warranty registration implies agreement to the terms of the "Acceptance of Responsibility" (above)

Device Serial #:		
Purchase date:		
Purchased from (Store / City):		
Purchaser:		
Purchaser address:		
City:	State:	Zip code:
Purchaser phone #:	E-mail:	



ToolTuff Direct
15000 W. 44th Ave., Suite B
Golden, CO

Questions? For service call or e-mail:
720-437-7640
customerservice@tooltuffdirect.com
techsupport@tooltuffdirect.com

HYPER ⚡ SPLIT