

DieHard®

Model No. DHL9000TiSRCO

9000W TRI-FUEL GENERATOR OPERATOR'S MANUAL

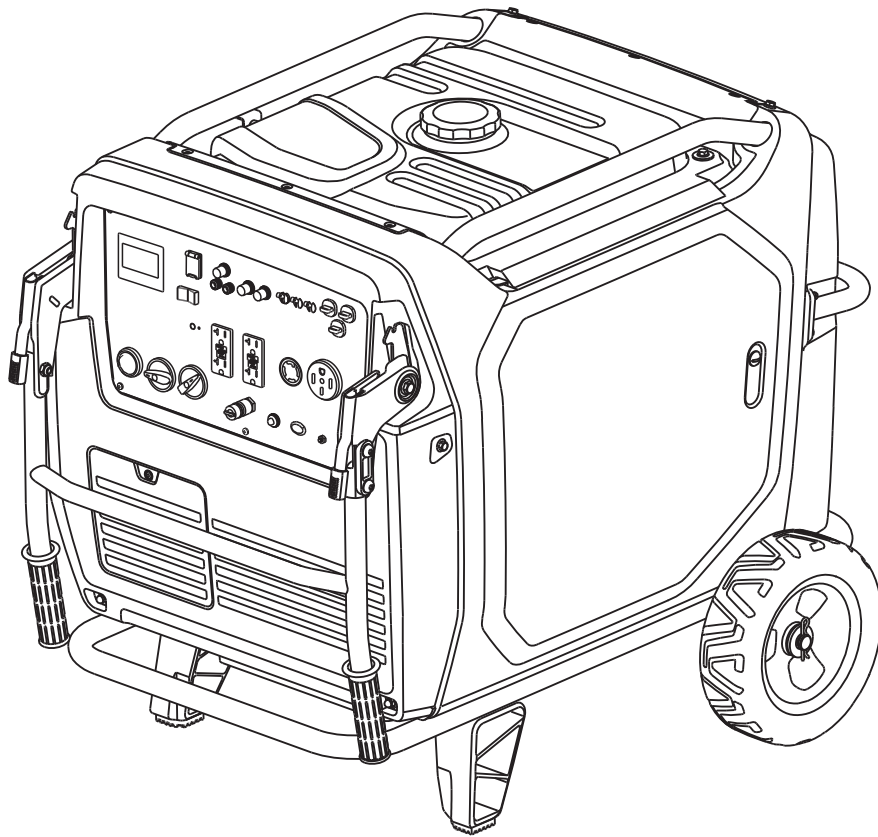

Warning: The Engine Exhaust from this product contains chemicals known to the State of California to cause cancer, birth defects or other reproductive harm.



DO NOT RETURN TO STORE!

HAVE QUESTIONS OR NEED SERVICE?

 **866-591-8921**

Table of Contents

Safety Warning.....	1	Shutting Down the Generator.....	13
Safety Instructions.....	2	Using the Generator.....	14
Assembly.....	5	Service and Maintenance.....	15
Components.....	6	Storage and Transport.....	18
Control Panel.....	6	Troubleshooting.....	18
Control Functions.....	7	Technical Parameters.....	19
Preparing the Generator.....	8	Electrical Schematic.....	20
Starting the Generator.....	11		

Introduction

Thank you for choosing DieHard!

This manual provides instruction on how to operate and use your generator safely and correctly; be sure to read and understand this manual before using your generator.

If you have ANY questions, please call 866.591.8921 M-F BEFORE using your generator. All details and images in this manual are believed to be accurate at the time of publication.

If the generator is resold, kindly include this manual with the generator.

Safety Warnings and Notices

DANGER

DANGER indicates an imminently hazardous situation which, if not avoided, will result in death or serious injury.

WARNING

WARNING indicates a potentially hazardous situation which, if not avoided, could result in death or serious injury.

CAUTION

CAUTION indicates a potentially hazardous situation which, if not avoided, may result in minor or moderate injury. It may also be used to alert against unsafe practices.

NOTICE

Failure to follow the instruction may result in the damage to your generator and other property.

Safety Instructions

Before operating your generator, you must read and understand the Operator's Manual and familiarize yourself with the safe operation practices.



NEVER use a generator indoors! Exhaust and Carbon Monoxide can KILL YOU in minutes.

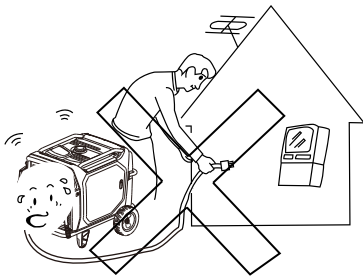

This is a portable generator, **DO NOT** attempt to connect it to any mains panel.

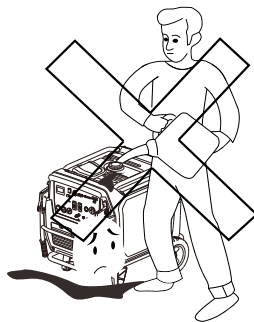

Take care not to spill any gasoline and wipe up any accidental spills at once.

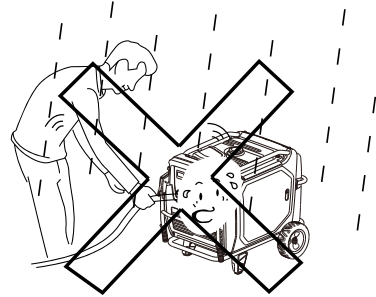

Avoid running the generator in the rain or very high, condensing humidity.

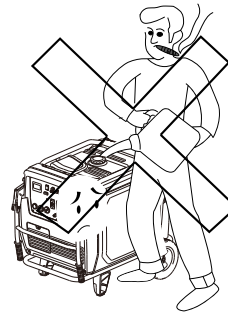

Never smoke or allow any heat source near the generator while refueling it.

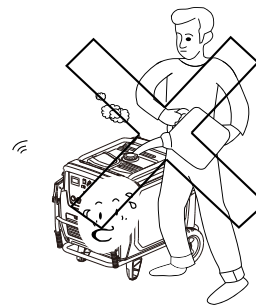

Always shut down the generator and allow it to cool before refueling!

Safety Instructions

NOTE

Improper treatment of the generator could damage it and shorten its life.

- Use generator only for intended applications.
- Operate generator only on solid, level surfaces.
- DO NOT expose the generator to excessive moisture, dust, dirt, or corrosive vapors.
- DO NOT insert any objects through cooling slots.
- If connected devices overheat, turn them off and disconnect them from the generator.

Shut off the generator if:

- Electrical output is lost.
- Equipment sparks, smokes, or emits flames.
- Unit vibrates excessively.

Parallel Kit Precautions



To prevent serious injury, death, and generator and/or equipment damage from electric shock and fire:

1. Follow Parallel Kit instructions provided with it for connection and use of a Parallel Kit.
2. Only connect two identical Inverter Generators together using a Parallel Kit.
3. Connect Parallel Kit only to terminals marked “Parallel” on the front of the Generator.
4. Do not remove or connect a Parallel Kit while the Generator is running.
5. Do not use a Parallel Kit that is attached to only one Generator.

Carbon Monoxide Safety

Carbon Monoxide

Generators are very convenient, but they can also be very dangerous. All fuel-burning appliances and equipment release a poisonous gas called carbon monoxide. Carbon monoxide (also known as CO) can be dangerous for humans and pets, even in small amounts, because it blocks oxygen from getting into your body. Carbon monoxide poisoning can lead to death in a very short time. It is odorless, tasteless and invisible, so you may be exposed without knowing it. That is why carbon monoxide is sometimes called “the silent killer.”

CO Sentry

The CO Sentry system was created to protect from dangerous carbon monoxide. Just like the detector for your home the CO Sentry tests the air for dangerous levels of carbon monoxide. If dangerous levels of carbon monoxide are detected this generator will automatically shutoff.



Automatic shutoff accompanied with a flashing RED light in the CO Sentry portion of the control panel is an indication that the generator was improperly located. If you start to feel sick, dizzy, weak, or carbon monoxide detectors in your home indicate an alarm, get to fresh air immediately. Call emergency services. You may have carbon monoxide poisoning.

CO Sentry Indicator Lights

RED

Carbon monoxide has accumulated around the generator. After shut-off, the RED indicator light in the CO Sentry area of the control panel will flash to provide notification that the generator was shutoff due to an accumulating CO hazard. The RED light will flash for at least five minutes after a CO shut-off. Move the generator to an open, outdoor area far away from occupied spaces with exhaust pointed away. Once relocated to a safe area, the generator can be restarted. Introduce fresh air and ventilate the area where the generator had shut down.

YELLOW

A CO Sentry system fault occurred. When a system fault occurs, the generator is automatically shut down and the YELLOW indicator light in the CO auto-shutoff area of the control panel will flash to provide notification that a fault has occurred. The YELLOW light will flash for at least five minutes after a fault. The generator can be re-started, but may continue to shutoff.

CO Sentry Label

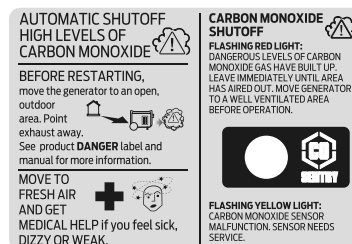
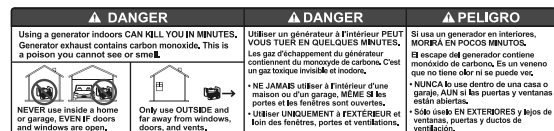

Safety Instructions

Button/Coin Battery Safety

⚠️ WARNING	
<ul style="list-style-type: none">• INGESTION HAZARD: This product contains a button cell or coin battery.• DEATH or serious injury can occur if ingested.• A swallowed button cell or coin battery can cause Internal Chemical Burns in as little as 2 hours.• KEEP new and used batteries OUT OF REACH OF CHILDREN• Seek immediate medical attention if a battery is suspected to be swallowed or inserted inside any part of the body.	



This symbol means:

INGESTION HAZARD: This product contains a button cell or coin battery.

1. Remove and immediately recycle or dispose of used batteries according to local regulations and keep away from children. Do NOT dispose of batteries in household trash or incinerate.
2. Even used batteries may cause severe injury or death.
3. Call a local poison control center for treatment information.
4. The nominal voltage of battery CR2032 is 3 volts, for more information, please check the generator manual or dealer.
5. Non-rechargeable batteries are not to be recharged.
6. Do not force discharge, recharge, disassemble, heat above 60°C(140°F) or incinerate. Doing so may result in injury due to venting, leakage or explosion resulting in chemical burns.

NOTE: THIS PRODUCT CONTAINS NON-REPLACEABLE BATTERIES

Assembly

WARNING

This product requires assembly. Do not attempt to operate this product if any items in the Assembly Parts List are already assembled when you remove the carton contents. These items are not assembled by the manufacturer and should require customer assembly. Using an improperly assembled product can be hazardous and could result in serious personal injury.

- Carefully open the carton and remove the carton contents.
- Inspect the carton contents. Verify that all the items in the Assembly Parts List are present and undamaged.
- Recycle or dispose of the packaging materials properly.

Assembly Parts List

A.



Wheel X2

B.

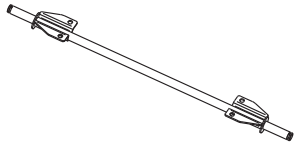

Axle X1

C.



Hitch Pin X2

D.



Washer X2

E.



M8 X 16 Bolts X8

F.



M6 X 25 Bolts X2

G.



Support Leg X2

H.



Rubber Pad X2

Installing Support Leg

- Parts needed-Support leg M8 screw (4).
- Raise the front end of the generator high enough to gain access to the bottom of the frame. Securely position props underneath for support.
- Line up holes on the support leg bracket to the holes on the front of the generator frame.
- Attach the support leg using M8 screws (2).
- Use a M6*25 bolt to connect the support leg and rubber pad.

Attaching Wheels

- Parts needed - 2 wheels, 1 axle, 2 hitch pins, and 2 washers.
- Raise or tilt generator so you can slide the wheel axle pin into the wheel, the washer, the wheel mounting hole located on the side of the frame.
- Secure the wheel assembly by reinserting a hitch pin through hole at the end of the wheel axle and pressing until it locks into place.
- Repeat process on the other side of the generator to install the second wheel.

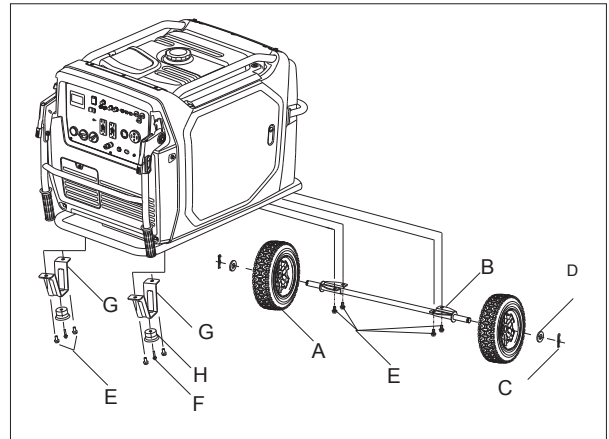

Components

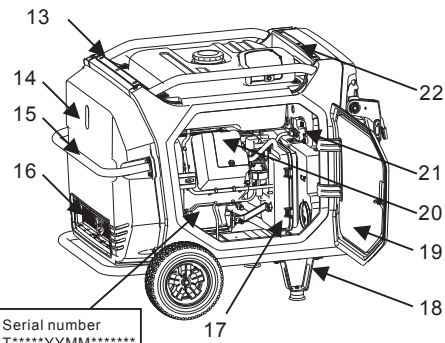
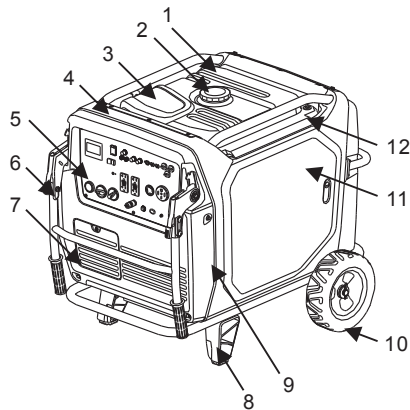

Serial number
T****YYMM*****
The YYMM is year
and month of
manufactured.

- | | |
|-----------------------------|---------------------------------|
| 1 Fuel Tank | 12 Seal Ring (fuel Tank) |
| 2 Fuel Tank Cap | 13 Tank Shroud (back) |
| 3 Fuel Gauge Cover | 14 Frame Shroud |
| 4 Frame | 15 Handle |
| 5 Control Panel | 16 Muffler, With Spark Arrestor |
| 6 Folding Handle | 17 Air Filter |
| 7 Battery Maintenance Cover | 18 Frame Shock Absorber Bracket |
| 8 Support Legs | 19 Left Maintenance Door |
| 9 Panel Bed | 20 Spark Plug |
| 10 Support Wheel Parts | 21 Combination Switch |
| 11 Right Maintenance Door | 22 Tank Shroud (front) |

Control Panel

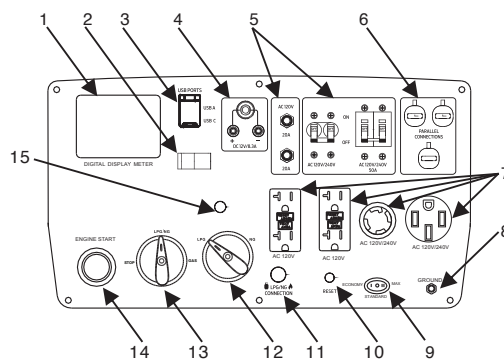

- | | |
|----------------------|--------------------------|
| 1 Data Display | 9 Low Idle Switch |
| 2 Voltage Selector | 10 Inverter Reset |
| 3 USB Charging port | 11 LPG /NG Connection |
| 4 DC Breaker | 12 Gas Selector (LPG/NG) |
| 5 AC Breaker | 13 Fuel Selector Valve |
| 6 Parallel Outlets | 14 Engine Start |
| 7 AC Receptacle | 15 CO Sentry Lamp |
| 8 Grounding Terminal | |

Control Functions

Fuel Selector Valve

1. Turn the generator OFF and place on a flat surface in a well ventilated area.
2. Rotate the Fuel Selector Valve to the "LPG/NG" position, select LPG or NG according to actual use.

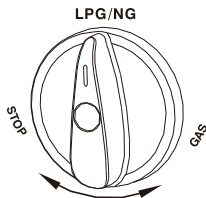

Starting

Press and hold the START switch for half-a-second, then release it.

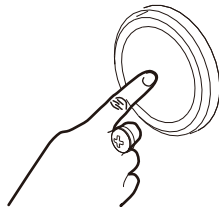

Remote Control

Remote Start: Aim the back of the remote FOB at the generator and press the START button twice.

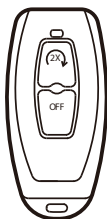

Energy Saving (Idle) Switch

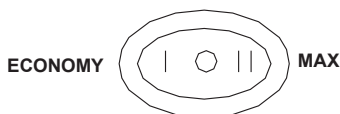

1. Turn the low idle Switch to "ECONOMY" to limit noise and fuel consumption when a light load is applied.
2. Move the Energy Saving Switch to "MAX" for full engine speed potential when:

- Starting the generator
- A heavy load is applied

Fuel Tank Cap

Remove fuel tank cap by unscrewing it counterclockwise.

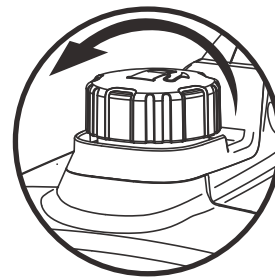

Reset

If the inverter is overloaded, the reset breaker will trip. The engine will continue to run, but there will be no output from the inverter. Unplug some devices to reduce the load. Push in the reset breaker to reset it.



Grounding Terminal

If grounding is required by code or application, follow the guidelines on page 14.



Preparing Your Generator

Engine Oil

CAUTION

DO NOT attempt to crank or start the engine before it has been properly filled with the recommended type and amount of oil. Damage to the generator because of failing to follow these instructions will void your warranty.

NOTICE

Failure to follow the instruction may result in damage to your generator and other property.

If running the generator in extreme temperatures, refer to the following chart for recommended oil type.

Recommended Engine Oil Type	
	10W-30
	5W-30
	10W-40
	5W-30 Full Synthetic
°F	-20 0 20 40 60 80 100 120
°C	-28.9 -17.8 -6.7 4.4 15.6 26.7 37.8 48.9
Ambient temperature	

1. Place the generator on a solid, flat, level surface.
2. Remove oil dipstick to add oil.
3. Using a funnel, as needed, add the appropriate type of oil until the oil level is at the proper level. SAE 10w-30 oil is recommended for general use. DO NOT OVERFILL. Replace oil dipstick and right maintenance door.

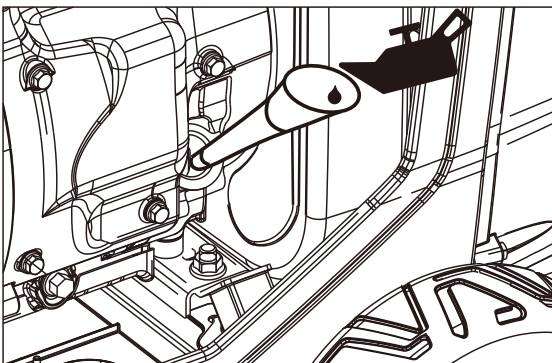

4. Check engine oil level daily and add as needed.

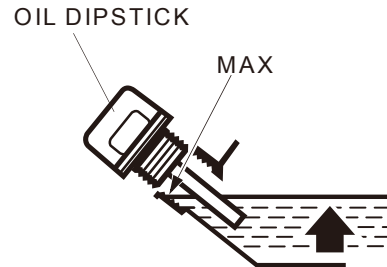

NOTICE

Once the oil has been added, a visual check should show oil about 1-2 threads from running out of the fill hole. When using the dipstick to check the oil level, DO NOT screw in the dipstick while checking (visually).

NOTICE

Check oil level often during the break-in period. Refer to the Service and Maintenance section for recommended service intervals.

CAUTION

This engine is equipped with a low oil shut-off and will stop when the oil level in the crankcase falls below a critical level.

NOTICE

The first 5 hours of run time are the break-in period for the unit. During the break-in period stay at or below 50% of the running watt rating and vary the load occasionally to allow stator windings to heat and cool. Adjusting the load will also cause engine speed to vary slightly and help seat piston rings. After the 5-hour break-in period, change the oil.

NOTICE

Synthetic oil may be used after the 5-hour initial break-in period. Using synthetic oil does not increase the recommended oil change interval. Full synthetic 5W-30 oil will aid in starting in cold ambient < 41°F (5°C) temperatures.

Preparing Your Generator

Fuel

⚠ DANGER

Gasoline is highly flammable and toxic. You must read and understand ALL safety instructions before fueling your generator.

Do not overfill the fuel tank! Heat and vibration can cause fuel to leak from an over-filled fuel tank.

After refueling, confirm that the fuel tank cap has been tightened.

NOTICE

Remove fuel tank cap and add gasoline to the red horizontal line.

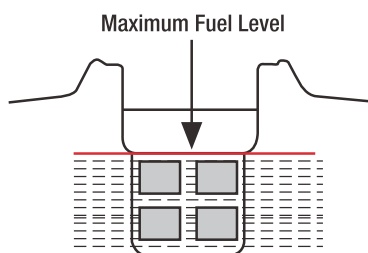

After fueling, wipe up any gasoline residue with a soft cloth to prevent damage to the plastic enclosures.

Fuel tank capacity: 6.6 US gallon(25L)

Connecting a Propane Tank

NOTICE

- Propane tanks that use liquid withdrawal system can not be used on these models.
- Confirm that the re-qualification date on the tank has not expired.
- DO NOT use included LPG hose for any other appliances.

Connecting a Natural Gas Hose

NOTICE

- Fire and Explosion Hazard! NEVER connect or disconnect ANY Gas Hose while the engine is running!
- Always shut the generator OFF and allow it to cool for at least 5 minutes before adding or removing ANY gas connection!

NOTICE

- All new propane tanks must be purged of air and moisture prior to filling. Used propane tanks that have not been plugged or kept closed must also be purged. The purging process should be done by a propane tank supplier (propane tanks from an exchange supplier should have been purged and filled properly).
- ALWAYS position the propane tank so the connection between the valve and the gas inlet will not cause sharp bends or kinks in the hose.

⚠ DANGER

Explosion hazard. DO NOT start generator if you smell propane ALWAYS fully close the propane tank valve and disconnect the LPG/NG hose from the generator when not in use. Never invert (turn up side down) a LPG tank while in use.

Connecting a Propane Tank

1. Turn the generator OFF and leave on a flat surface in a well ventilated area.
2. Verify that the propane tank valve is in the fully closed position

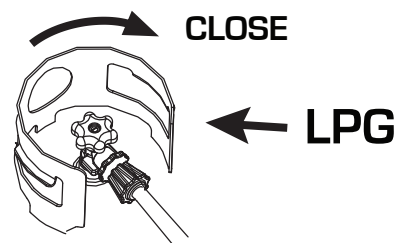

IMPORTANT: DO NOT use thread seal tape or any other type of sealant to seal the LPG hose connection.

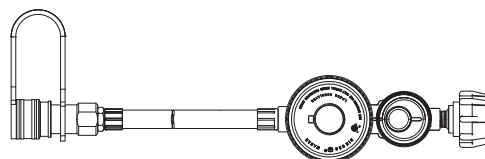

Preparing Your Generator

3. Remove the cover on the generator gas inlet.

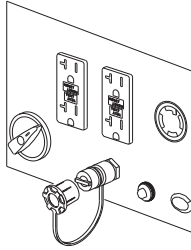

4. Push back the quick connect collar on the Propane hose, fit it securely over the Gas Inlet, and release the collar. Check for a secure connection.

5. Remove the safety plug or cap from the propane tank valve and attach the other end of the hose to the LPG connector on the tank. Hand-tighten. Then turn the fuel selector switch to "propane".

6. Turn the propane tank valve to the fully open position. Check all connections for leaks by wetting the fittings with a solution of soap and water. Bubbles which appear or bubbles which grow indicate that a leak exists. If a leak exists at a fitting, turn the propane tank valve to the fully closed position and tighten the fitting. Open the propane tank valve and recheck the fitting with the soap and water solution. If the leak continues or if the leak is not at a fitting then DO NOT use the generator and contact an authorized Pulsar service center.

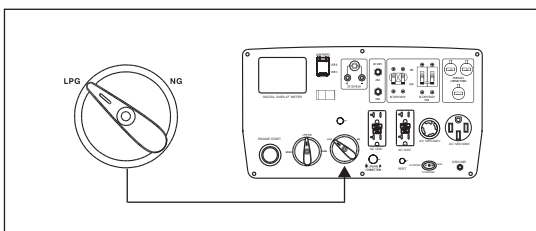
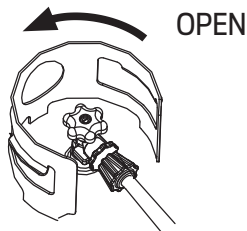
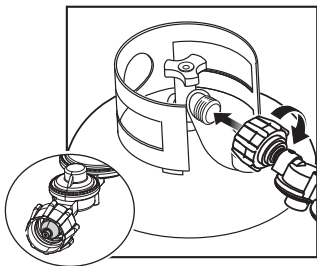

NOTICE

- Fire and Explosion Hazard! NEVER connect or disconnect ANY Gas Hose while the engine is running!
- Always shut the generator OFF and allow it to cool for at least 5 minutes before adding or removing ANY gas connection!

⚠ DANGER

- To reduce the risk of injury, perform a leak test any time the natural gas hose is disconnected and reconnected.
- Never use a natural gas supply line, natural gas hose, or any other fuel item that appears to be damaged.

Connecting Natural Gas

1. This tri-fuel generator includes a Quick Connect supply hose and an NPT-to-QC fitting for your gas supply line; this must be installed by a licensed gas contractor. The NPT threads must be sealed with gas-rated Teflon tape or other code approved sealant and torqued correctly.
2. A proper gas line installation will include a quarter-turn gate valve and a female Quick Connect fitting.
3. Keep your Quick Connect Gas fittings covered and plugged when not in use.
4. Your Natural Gas supply hose has a male and a female quick connect fitting on each end for an easy connection, without tools.
5. Before operation, you must test this gas connection for leaks. Turn ON the gas valve and spray all fittings with a soapy water solution. Any bubbles that form indicate a leak, you must stop at once and contact your gas contractor for a repair. 6. Once a leak-free connection has been verified, you may turn the fuel selector to Natural Gas and start the generator.

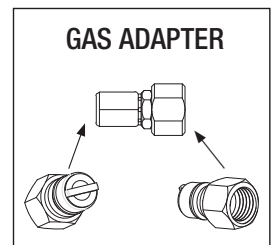
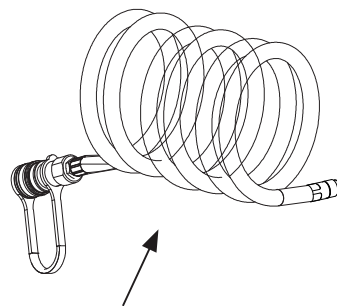

Natural Gas Hose (both ends are Quick Connect)

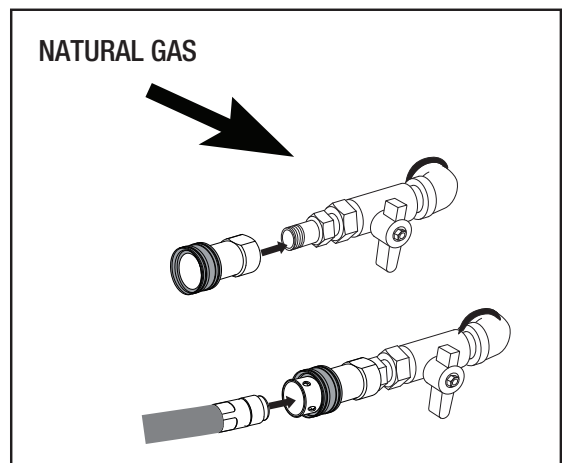

Preparing Your Generator

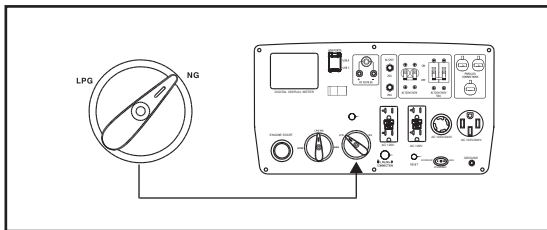
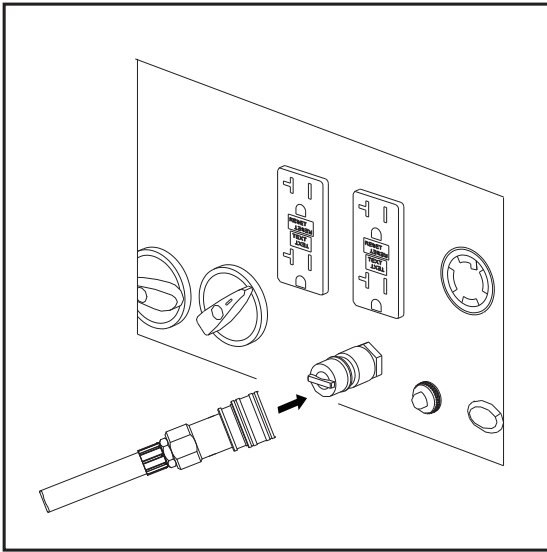

Connecting the Battery

A quick-connect battery plug is pre-installed on the battery. Remove the cable tie securing the plugs, align colors, then push firmly to connect them.

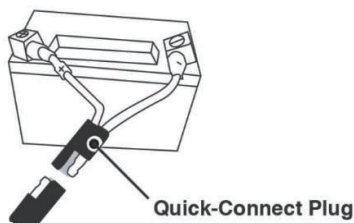

Note: The generator is equipped with a battery charging feature. Once the engine is running, a small current will slowly recharge the battery.

Grounding the Generator

Attach grounding wire (if required by code)

- Ground the generator by tightening the grounding nut against a grounding wire.
- Connect the other end to a copper or brass grounding rod that's driven into the earth.

A generally acceptable grounding wire is a No. 12 AWG (American Wire Gauge) stranded copper wire. Grounding codes can vary by location.

Please contact a local electrician to check the grounding regulations for your area.



Failure to properly ground the generator can result in electrocution.

Starting the Generator

1. Make sure the generator is on a solid, flat, level surface.
2. Disconnect all electrical loads from the generator. Never start or stop the generator with electrical devices plugged in or turned on.
3. Select Fuel Source
 - a. Gasoline: Turn Fuel Selector Valve.
 - b. LPG/NG: Connecting to LPG/NG, Turn fuel selector valve to "LPG/NG" position.

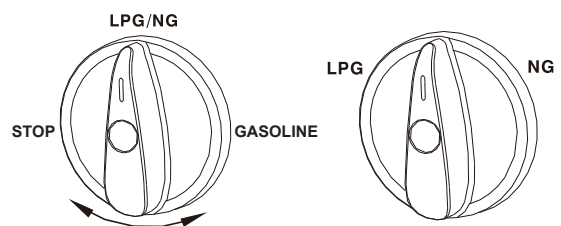

Please refer to "Connecting an LPG/NG source" for the connection steps.

Starting The Generator

NOTICE

Gasoline and LPG/NG cannot be used simultaneously, otherwise it may cause damage to the generator and reduce its service life. When preparing to use propane as a fuel, all loads must be removed, the generator must be turned off, and the fuel selector valve must be turned off.

Choose the starting method

Electric Start: Press and hold the START switch for half a second, then release it.

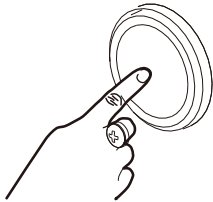

Remote Start: Aim the back of the remote FOB at the generator and press the START button twice.

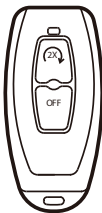

Recoil Start: Pull the recoil handle out until resistance is felt. Let it retract, then pull it swiftly and fully.

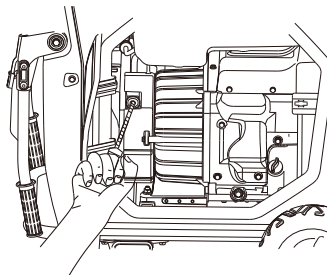

Plug in Devices

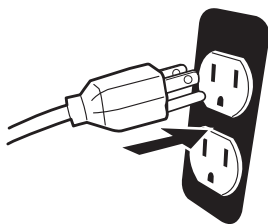

⚠ DANGER

Fire and explosion hazard. Always turn the propane tank valve to the fully closed position if not running the generator on propane.

⚠ WARNING

When using the generator with propane, make sure there is no possible ignition source close to the generator.

Parallel Operation

The parallel connection ports allow you to connect two generators to increase the total available electrical power. Follow the instructions included with your parallel connection kit for proper installation and operation.

Overload Indicator

Note: The OVERLOAD lamp may turn on for a few seconds as a large device starts. This is normal for loads approaching the capacity of this generator.

1. The total combined load through the outlets on the generator must not exceed the running power of the unit.
2. If the OVERLOAD lamp turns on and the generator stops producing power, it has been overloaded.
3. Turn off and disconnect all electrical devices and stop the engine. Compare device requirements to generator rating and reduce the total wattage of connected devices if necessary. Move anything that may be limiting generator ventilation away.
4. Check if any circuit breakers have tripped and make sure that ALL circuit breakers are reset before starting the generator again.
5. Restart the engine and reconnect devices while being careful to not overload the generator.

Low Oil Indicator

1. If the engine oil level is too low, the LOW OIL light turns on and the engine will automatically shut off.
2. The engine cannot be restarted until the proper amount of oil has been added. Add the appropriate type of oil until the oil level is at the proper level. SAE 10w-30 oil is recommended for general use.

Starting The Generator

NOTICE

Do not run the engine with too little oil. Engine will shut off if engine oil level is too low.

Changing the Neutral Point

This generator is "neutral floating" state, if you want to change to a "neutral bonded" state, insert the Bonding Plug into the output socket of the generator to change the neutral floating to neutral bonded state.

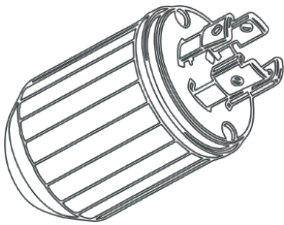

NEMA L14-30P Bonding Plug

Shutting Down The Generator

1. Turn off and unplug all connected electrical loads. Never start or stop the generator with electrical devices plugged in or turned on.

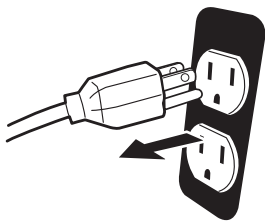

2. Press the engine switch or press the remote start button "off" once to stop the generator.

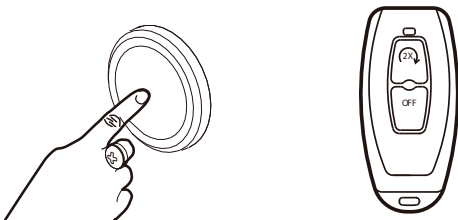

3. Close the LPG tank valve or NG supply valve.

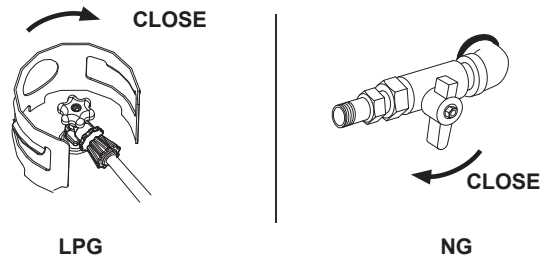

4. Turn fuel selector valve to "STOP" position.

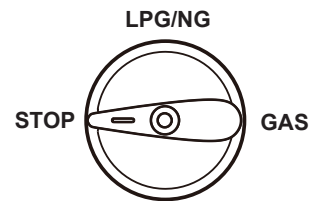

5. After the generator has completely cooled down, remove the LPG/NG hose if applicable and store the generator in a cool, dry, sheltered storage area.
6. Remove or consume all untreated gasoline if you plan to store the generator longer than 3 months.

Generator Capacity

NOTICE

Do not overload the generator's capacity. Exceeding your generator's wattage capacity can damage the generator and/or electrical devices connected to it.

Make sure the generator can supply enough continuous (running) and surge (starting) watts for the items you will power at the same time.

The total power requirements (Volts \times Amps = Watts) of all appliances connected must be considered. Appliance and power tool manufacturers usually list rating information near the model or serial number. To determine power requirements:

Using the Generator

Operating Range of the Generator

- Ambient air temperature: 23F–104F (-5 ~ 40°C)
- Relative humidity <95%
- Recommended elevation <5,000 feet (1,500m) reduced power at >3,300 feet (1,000 m)

Ideal Atmospheric Conditions

- Ambient air temperature: 77F (25°C)
- Relative humidity: 30%
- Atmospheric pressure: 1,000 millibars

Standard Deration

- Every 9°F (5°C) increase in ambient air temperature will reduce generator output by about 2%
- Every 30% of increase in relative humidity of air will reduce generator output by about 1.5%
- Every 1,000 feet, (300m) elevation increase will reduce generator output by about 4.5%

Connecting Loads to the Generator

- ① Start the engine
- ② Move Energy Saving switch to "OFF"
- ③ Insert the plug(s) into AC outlet(s)
- ④ Make sure that AC indicator is illuminated
- ⑤ Switch on electrical equipment

Tip: If total load is less than half rated capacity, move the Energy Saving Switch to 'ON'. If the generator supplies power to multiple devices plug-in those devices in from large to small according to rated electrical load.

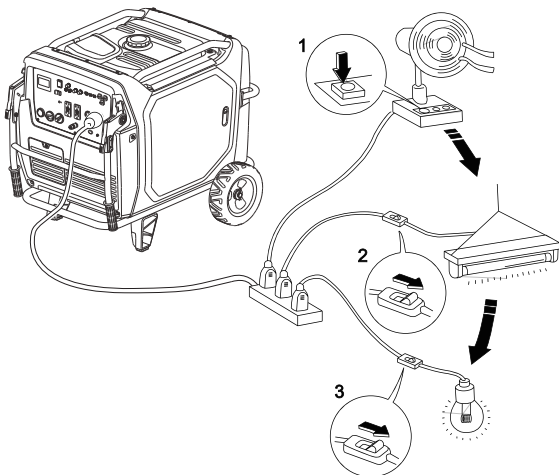

Generator Grounding

If grounding is required by code or application, follow the guidelines below. If you have ANY doubt, contact a licensed electrician.

- ① Use grounding wire of minimum 12 gauge
- ② Connect one end of grounding wire to the grounding bolt on the control panel.
- ③ Connect the other end of the grounding wire to a suitable ground point.

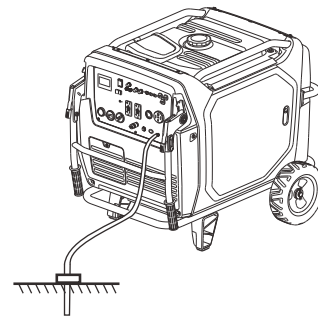

Range of Application

Before using the generator, please make sure that total load is within rated load range of the generator, otherwise the generator may be damaged.

Service and Maintenance

Good maintenance is essential for safe, economical operation and long service life. The maintenance schedule is below:

Maintenance Cycle	Item	Each Week	Break-In Maintenance at 1 Month or 20 Hours Use	Quarterly Maintenance is every 90 Days or 50 Hours Use	Annual Maintenance or 100 Hours Use
Engine oil	Check - Fill	√			
	Replace		√	√	√
Air Cleaner Element	Inspection	√			
	Clean		√		
	Replace			√	√
Carburetor Float Bowl	Clean				√
Spark Plug	Clean - Adjust				√*
Spark Arrester	Clean			√	
Idle Speed	Check - Adjust				√
Valve Clearance **	Check - Adjust				√
Fuel Tank and Fuel Filter **	Clean				√
Fuel Hose	Inspection	Every Two Years			
Cylinder Head, Piston	Remove Carbon Deposit **	Displacement <225cc, every 125 hours; displacement ≥225cc, every 250 hours.			
** These tasks should be completed by an authorized DieHard service center.					

Service and Maintenance

NOTICE

If the generator is used in high temperature or under high load, change the oil every 25 hours.

If the generator is used in a dusty or abrasive environment, service the air filter element every 10 hours; replace it every 25 hours.

If you miss a maintenance cycle, perform the maintenance as soon as possible per the table above.

⚠ DANGER

Shut down the engine and allow it to cool before performing any service. Place the generator on a flat, stable surface. Remove the spark plug boot to prevent accidental engine start.

NEVER USE ANY GENERATOR INDOORS or in any poorly ventilated area. Engine exhaust contains carbon monoxide which can KILL you and others in the area.

Spark Plug

- 1) Remove access cover and spark plug boot.
- 2) Use the (included) thin-wall T-socket wrench to remove the spark plug by turning it counter-clockwise.

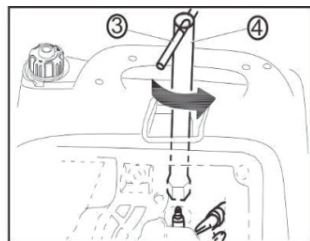
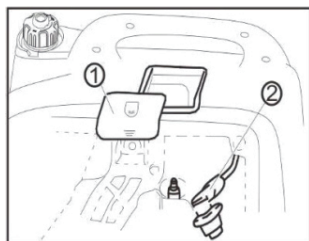

- 3) Inspect spark plug for discoloration and remove carbon deposits; replace if necessary.
- 4) Adjust the gap 0.7~0.8mm.

Spark Plug # **F7RTJC**
Gap: 0.7-0.8mm



- 5) Install new or serviced spark plug in reverse order.

Spark Plug torque: 13~15 Nm; 115~133 in lbs.

Tip: If no torque wrench is available turn the spark plug ¼ - ½ turn after the gasket contacts the cylinder head.

Adjustment of the Carburetor

This carburetor is not adjustable, only maintenance and cleaning are possible. We strongly recommend leaving this work to an authorized Pulsar Service center.

Oil Change

⚠ WARNING

Do not drain the oil immediately after turning off the generator; allow it to cool completely before servicing it.

- 1) Raise the generator up on support blocks on a flat, stable surface
- 2) Loosen the knob on the right cover ① and remove the right cover ②.
- 3) Unscrew oil dipstick ③
- 4) Place an oil pan under the engine, tilt the generator toward the oil pan until all oil has drained; wipe up any spills.

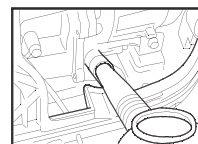
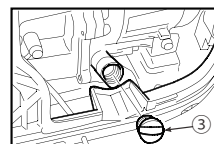
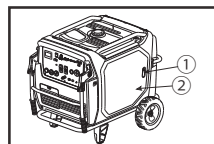

- 6) Re fill crankcase with 45 ounces (1.35L) 10w-30 engine oil; check with dipstick.
- 7) Tighten oil dipstick, replace oil access cover, and tighten the knob.

Air Filter

A dirty air filter can cause poor performance and engine damage. Perform inspection and cleaning per the maintenance schedule on page 15.

Service and Maintenance

Air Filter

- 1). Loosen the knob on the right cover ① and remove the right cover ②.
- 2). Remove screws ③, to remove air filter housing ④;
- 3). Remove foam filter element ⑤;
- 4). Clean foam filter element with a mild soap solution, rinse well and let it dry
- 5). Place a few drops of engine oil on the foam filter element and squeeze gently to distribute the oil film evenly
- 6). Reinstall the air filter element in reverse order.

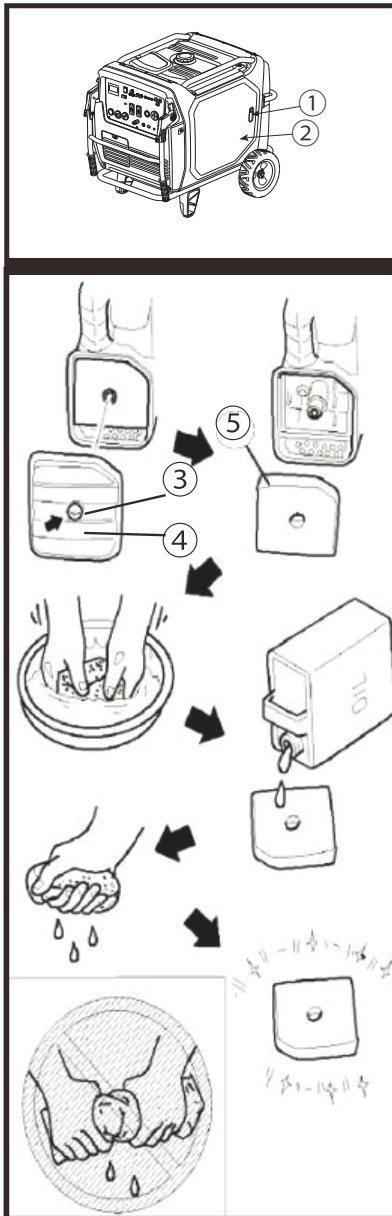

Fuel Filter Screen

! DANGER

NEVER approach the generator while smoking or with any ignition source!

1. Remove fuel tank cap and fuel tank filter screen.
2. Clean fuel tank filter screen with mild soap and hot water.
3. Allow filter screen dry thoroughly and replace it in the fuel tank.
4. Replace fuel cap tightly.

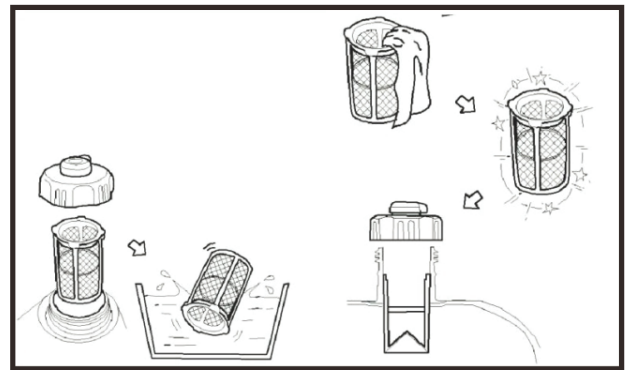

Storage and Transport

Generator Long Term Storage

1. Turn off the generator and allow it to cool completely.
2. Remove the spark plug boot to prevent accidental engine start.
3. Remove bolts and right service access panel
4. Using a Phillips screwdriver, open fuel drain valve on the carburetor, and drain remaining fuel into an approved gasoline container.
5. Tighten fuel drain valve.
6. Change engine oil per page 15.
7. Remove spark plug and instill one teaspoon (5ml) new engine oil into combustion chamber. Pull the recoil a few times, to distribute oil, then reinstall the spark plug.
8. Replace right service access panel.
9. Gently pull recoil handle until you feel resistance, indicating the intake and exhaust valves are closed.
10. Store the generator in a clean and dry area.

Storage and Transport

Generator Transport

Pulsar Products recommends that the generator should be empty of fuel when transported unless the generator is secured in an open truck bed and secured from tipping. In this case, follow the guidelines below:

- Do not completely fill the fuel tank, leave some expansion space.
- Do not run the generator while transporting.
- Protect from direct sunlight.
- Do not transport the generator across rough terrain.

Troubleshooting

Engine No-Start

Fuel System

- 1) There is no fuel.
- 2) Fuel doesn't reach combustion chamber.
- 3) Contaminated or old fuel.
- 4) There is debris in the fuel valve.
- 5) Carburetor is fouled, service carburetor.

Insufficient Engine Oil

Oil level is too low.

Ignition System

- 1) Make sure the generator is off.
- 2) No spark from ignition coil failure.
- 3) Spark plug is fouled, service it per page 16.

Low Compression

- 1) Worn out engine.
- 2) Cylinder head bolts have loosened, have an authorized Pulsar Service Center re-torque them properly.
- 3) Head gasket leak.

Engine Runs, No Power Output

- 1) Ensure all circuit breakers are pushed in.
- 2) If generator was exposed to moisture or rain, move it to a dry location for several hours.
- 3) Vibration may have caused one or more connectors to loosen over time, check with Pulsar Technical Support for guidance.
- 4) Check electrical receptacles for damage.
- 5) Generator may be overloaded. Remove load, shut down, then restart the engine.

Technical Parameters

Model		DHL9000TiSRCO
Generator	Type	Inverter
	Rated Frequency/Hz	60
	Rated Voltage/V	120/240
	Rated Power COP/kW	7.2 (Gasoline) / 6.5 (LPG) / 5.75 (NG)
	Starting Watts /kW	9.0 (Gasoline) / 8.1 (LPG) / 7.2 (NG)
	Power Factor	1.0
	AC Output Quality	ISO8528 G2
	THD/%	≤1.5
	Noise Level dB/LpA/LwA/ 4m (3/4 load)	70 / 90
	DC Output/ V-A	12-8
	Overload Protect	DC
AC		Inverter Controlled Overload Protect Program
Engine	Engine	HM420G-2B
	Engine Type	Single Cylinder, 4-Stroke, Forced Air Cooling, OHV
	Displacement/cc	420
	Fuel Type	Gasoline/LPG/NG
	Fuel Capacity/Gallons	6.6
	Continue Running Time (at rated power) / h	6.5
	Oil Capacity/L	1.35
	Spark Model No.	F7RTJC
	Starting Mode	Recoil Start, Electric Start, Remote Start
Generator	Length×Width×Height	37.4"×30.1"×30.5"
	Net Weight	125 kg. (275 Lbs.) (CAUTION - HEAVY, 275 Pounds)
	Wheel / Inch	2×9.5

Electrical Schematic

