

Angled/Pivoting Spare Tire Carrier

Installation Instructions Part #86062 & 86063

This kit contains the following components:

#	Qty.	Part #	Description
1	1	40040	Pivoting Spare Tire Carrier
2	1	12601AT	Knob and Cable Assembly
3	2	84470-1Z	Ubolt 1/2-13 x 3.13" x 4" zinc
	2	84472-1Z	Ubolt 1/2-13 x 4.06" x 4.31" zinc
	2	84433-1Z	Ubolt 1/2-13 x 5.06" x 4.06" zinc
4	4	10645	Nyloc Nut 1/2-13 zinc
5	3	10640	Push Bolt Retainer 1/2"
6	3	10641	Lug Nut 1/2-20 zinc Grade 5
7	3	10863	Carriage Bolt 1/2-20 x 1-3/4" zinc

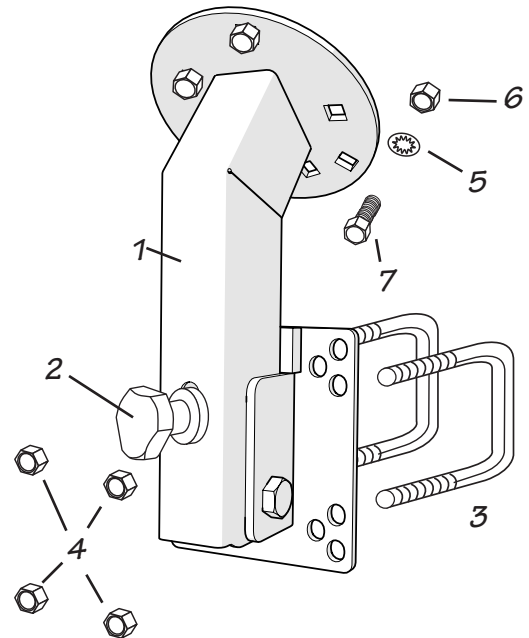

Mounting Instructions

1. Use the spare tire carrier and spare tire as a guide, determine a suitable mounting location on trailer frame.
2. Use the spare tire carrier to determine the correct mounting holes to use, place the u-bolts provided (one set of u-bolts for 3", 4" and 5" trailer frames) over the frame and through the mounting plate. loosely attach with nyloc nuts, do not tighten.
3. Remove the pivot knob (2) and lower the tire carrier.
4. Use the spare tire to determine the correct holes to use on the face of the carrier. Place the carriage bolts in the holes provided to mount the spare tire. Bolt heads (7) should be on the back side of the tire carrier. Secure bolts with retainers (5).
5. Mount the spare tire. Swing the spare tire upward and secure the pivot carrier with the pivot knob
6. Check position of the tire mount for proper clearance with the spare tire before tightening nuts.
7. Once position is determined tighten all mounting nuts.

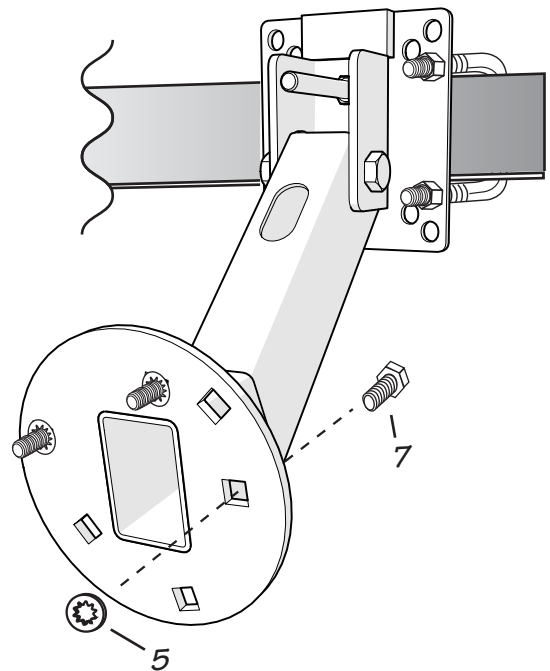

Instructions #08280 (A1508 - Rev. 3/18/19)