

## DIY Table Corner Kit Installation Instructions

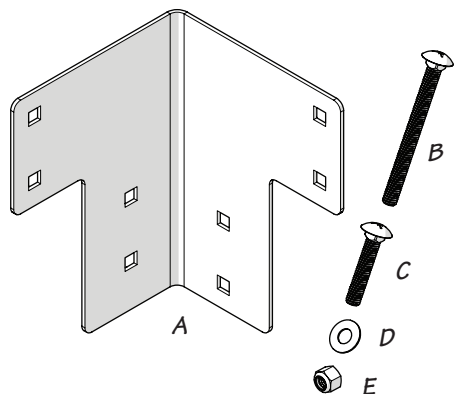

### Table Corner Kit #33008

A	Corner Bracket (White)	4
B	Carriage Bolt 3/8"-16 x 4"	16
C	Carriage Bolt 3/8"-16 x 2"	16
D	Washer 3/8"	32
E	Locknut 3/8"-16	32

### Table Corner Kit #33009

A	Corner Bracket (White)	8
B	Carriage Bolt 3/8"-16 x 4"	32
C	Carriage Bolt 3/8"-16 x 2"	32
D	Washer 3/8"	64
E	Locknut 3/8"-16	64

### Table Corner Kit #33010

A	Corner Bracket (Black)	4
B	Carriage Bolt 3/8"-16 x 4"	16
C	Carriage Bolt 3/8"-16 x 2"	16
D	Washer 3/8"	32
E	Locknut 3/8"-16	32

### Table Corner Kit #33011

A	Corner Bracket (Black)	8
B	Carriage Bolt 3/8"-16 x 4"	32
C	Carriage Bolt 3/8"-16 x 2"	32
D	Washer 3/8"	64
E	Locknut 3/8"-16	64

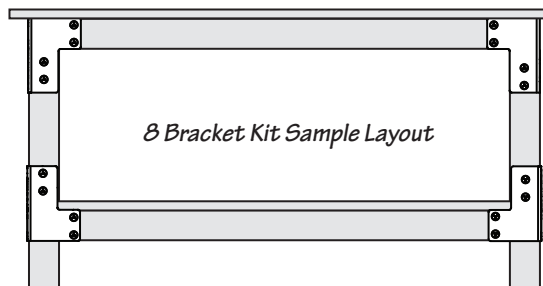
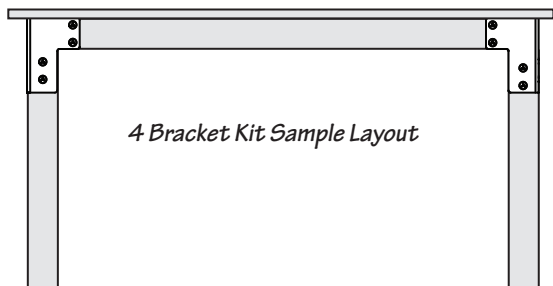

Online  
Instructions

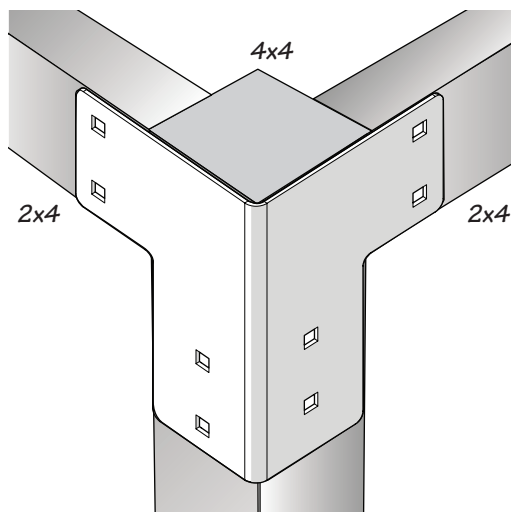

### Determine Table Dimensions:

- Decide on the desired height and width of the table, accounting for the counter top thickness.
- Cut four 4x4s to the desired table height, subtracting the counter top thickness to get the correct leg length.
- Cut two 2x4s for the table width.  
Note: Subtract 7 inches from the total desired width to account for the thickness of the 4x4 table legs on each side.
- Cut two 2x4s for the table length.  
Note: Subtract 7 inches from the total desired length to account for the 4x4 leg spacing.

These measurements ensure that the frame will fit properly within the footprint created by the 4x4 legs, providing a sturdy and properly aligned base for the tabletop.



**WARNING:** This product can expose you to chemicals including Nickel, which is known to the State of California to cause cancer. For more information go to: [www.P65Warnings.ca.gov](http://www.P65Warnings.ca.gov)

Instructions #08480 (EC2088 - Rev. 6/10/25)

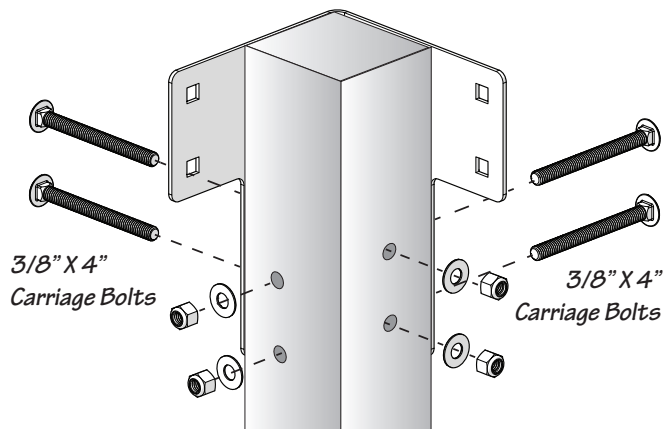

### Step 1

- Position the corner bracket flush to the top of the table leg.
- Using a pencil/marker, mark mounting hole locations on the table leg for the 4" carriage bolts. Remove the corner bracket.
- Using a power drill with a 7/16" bit, drill four holes matching the marked locations on the table leg.

## DIY Table Corner Kit Installation Instructions

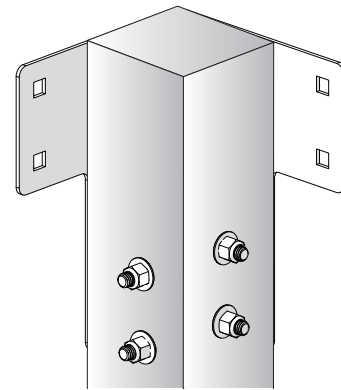

### Step 2

- Position the corner bracket flush to the top and matching the drilled hole locations.
- Pass 4" carriage bolts through the corner bracket and table leg.
- Place a 3/8" washer and locknut over each carriage bolt. Loosely tighten all four bolts, do not fully tighten

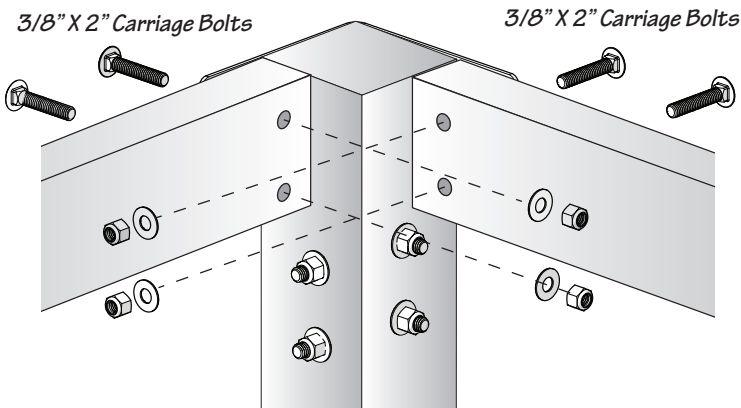

### Step 3

- Position the 2x4s flush to the top of the corner bracket/table leg.
- Using a pencil/marker, mark mounting hole locations on the cross-member for the 2" carriage bolts. Remove the cross-member.
- Using a power drill with a 7/16" bit, drill two holes matching the marked locations from the corner bracket.
- Repeat for the opposite cross-member.

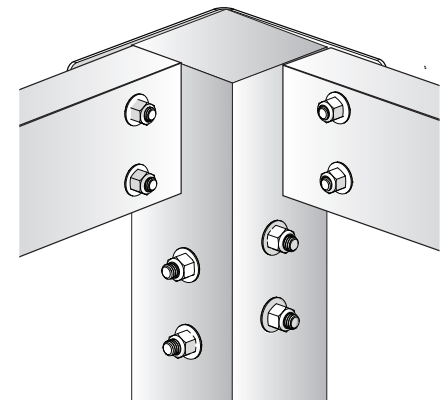

### Step 4

- Position the 2x4s flush to the top corner bracket/table leg matching the drilled hole locations.
- Pass 2" carriage bolts through the corner bracket and table leg.
- Place a 3/8" washer and locknut over each carriage bolt. Loosely tighten all four bolts, do not fully tighten

### Step 5

- For the 8 bracket kits, repeat steps 1-4 for the brace/shelf brackets.
- Once all the legs and cross-members are fully assembled, position the table in its final location.
- Check the all the legs are contacting the floor and the table is level. Fully tighten all the locknut's/carriage bolts.
- Attach the table top.