

OWNER'S/OPERATOR'S MANUAL

WARNING:

Read this Manual, and any Supplements Carefully Before Operating the Vehicle. This manual covers important information about:

- Safety
- Assembly
- Operation • Maintenance

THIS VEHICLE IS NOT DESIGNED FOR USE ON RENTAL TRACKS OR RACING

Explorer 450 T & T4

● **BEFORE OPERATING THIS VEHICLE, THE OWNER AND EACH OPERATOR MUST HAVE READ AND HAVE AN UNDERSTANDING OF ALL THE INSTRUCTIONS FOR PROPER ASSEMBLY AND SAFE OPERATION, AS WELL AS THE INSTRUCTIONS CONCERNING THE ENGINE AND ALL OTHER PORTIONS OF THE VEHICLE.**

NOTE: A storage area/toolbox has been provided on the UTV for storage of this manual.

Please keep this manual in the storage box so that it can be found easily and referenced when needed.



CONTENTS

1. INTRODUCTION	1.1
2. UNDERSTANDING WARNINGS	2.1
3. SAFETY WARNING.....	3.1
4. DAILY PRE-RIDE INSPECTION.....	4.1
5. OPERATION WARNING.....	5.1
6. V.I.N. NUMBER.....	6.1
7. CONTROL AND FUNCTIONS.....	7.1
8. STARTING THE ENGINE.....	8.1
9. BREAK-IN.....	9.1
10. RIDING WEAR.....	10.1
11. CARRYING LOADS.....	11.1
12. CVT SYSTEM.....	12.1
13. EXHAUST SYSTEM.....	13.1
14. BATTERY.....	14.1
15. TROUBLESHOOTING.....	15.1
16. SPECIFICATIONS.....	16.1
17. ELECTRICAL DIAGRAM.....	17.1
18. MAINTENANCE.....	18.1
19. EMISSION WARRANTY.....	19.1

1. INTRODUCTION

Introduction

Congratulations on the purchase of your Utility Task Vehicle (UTV). We take pride in offering you this product engineered and manufactured to the highest performance and quality standards. We are sure that you will enjoy superior levels of performance, reliability, riding comfort, and safety.

This manual is provided to help the owner and operators of this UTV become familiar with the operating characteristics, and the many features offered on the UTV. The manual also covers information on the care and maintenance of your UTV.

Please read this manual carefully. The information contained in this Owner's Manual and the Warning Labels supplied with this product will help you to understand the safe use and maintenance of your UTV. Make sure that you understand and follow all Warnings and Instructions in this material.

If you did not receive any of the material listed above, please call your dealer and request to have it sent to you.

Product and specifications are subject to change without notice.

1. INTRODUCTION

Important Safety Notice

- This vehicle is designed and manufactured for off-road use only. It is illegal to operate this vehicle on any public street, road, or highway. Such use is prohibited by law.
- Check the local laws and regulations before choosing where to operate this vehicle. It is illegal to operate this vehicle on public lands where vehicles its size are prohibited.
- Never make any modifications to the engine, drive system, mechanical or electrical systems of your UTV. Never install aftermarket parts or accessories intended to increase the speed or power of your UTV.
- Failure to follow these warnings increases the possibility of accidents leading to DEATH or SERIOUS INJURY!
- Additionally, failure to follow these requirements will void the Warranty on your UTV.

NOTE

The addition and use of certain accessories including, (but not limited to) mowers, blades, sprayers, winches and windshields will change the handling characteristics and the performance of your UTV.

Practice Responsible UTV Riding

Make sure that you understand and follow all local, state/province, and federal/national riding laws and requirements.

Remember: Respect your vehicle, respect the environment and respect the property of others. You are responsible for your safety and the safety of others around you when you ride!

1. INTRODUCTION

A UTV CAN BE HAZARDOUS TO OPERATE.

A UTV handles differently from other vehicles including motorcycles, ATVs and cars. A rollover can occur quickly, even during routine maneuvers such as turning and driving on hills or over obstacles, if you fail to take proper precautions.



SERIOUS INJURY OR DEATH can result if you do not follow these instructions.

- Read this manual and all labels carefully and follow the operating procedures described.
- This vehicle is designed to carry the driver and one passenger. Never carry passengers in the cargo bed.
- Always be sure the driver and passenger are wearing seat belts.
- Never allow anyone who is not an adult to operate this UTV.
- Never permit a guest to operate this UTV unless the guest has read this manual and all product labels.
- The driver and passenger must wear approved off-road motorcycle-type helmets that fit properly. The driver and passenger should also wear eye protection (glasses or face shields), gloves, boots, long-sleeved shirt or jacket, and long pants.
- As with any off-road-capable vehicle, there is a risk of tip over or rollover under certain conditions. Uneven terrain or slopes which pitch the vehicle sideways, turning too fast or sharp, or a combination of conditions increase the risk of tip over.
If you are in a situation where the vehicle is tipping over, do not put your arm and/or leg outside the vehicle, do not try to stop tipping with your arm or leg. You could be severely injured. You could suffer a crushed hand, arm, leg, or foot, if part of your body is caught underneath the vehicle.
You must keep your arms and legs inside the vehicle until it has stopped moving.
- Never consume alcohol or drugs before or while operating this UTV.
- Never operate at excessive speeds. Always travel at a speed which is proper for the terrain, visibility and operating conditions, and your experience.

1. INTRODUCTION

- Never attempt wheelies, jumps or other stunts.
- Always inspect your UTV each time you use it to make sure it is in safe operating condition. Always follow the inspection and maintenance procedures and schedules described in this manual.
- Always keep both hands, arms, feet, and legs inside the vehicle at all times during operation. Keep your feet on the floorboard. Never hold onto the enclosure except when using the handgrip inside the enclosure. Otherwise, your hand could be injured if it is caught between the enclosure and an obstacle outside the vehicle.
- Always keep both hands on the steering wheel when driving.
- Never wrap your thumbs and fingers around the steering wheel. This is particularly important when driving in rough terrain. The front wheels will move right and left as they respond to the terrain, and this movement will be felt in the steering wheel. A sudden jolt could wrench the steering wheel around, and your thumbs or fingers could be injured if they are in the way of the steering wheel spokes.
- Always go slowly and be extra careful when operating on unfamiliar terrain. Always be alert to changing terrain conditions when operating the UTV.
- Never operate on excessively rough, slippery or loose terrain.
- Always follow proper procedures for turning as described in this manual. Practice turning at low speeds before attempting to turn at faster speeds. Do not turn at excessive speed.
- Always have the UTV checked by an authorized dealer if it has been involved in an accident.
- Never operate UTV on hills too steep for the UTV or for your abilities. Practice on smaller hills before attempting larger hills.
- Always follow proper procedures for climbing hills as described in this manual. Check the terrain carefully before you start up any hill. Never climb hills with excessively slippery or loose surfaces. Never open the throttle suddenly or make sudden gear changes. Never go over the top of any hill at high speed.

1. INTRODUCTION

- Always follow proper procedures for going down hills and for braking on hills as described in this manual. Check the terrain carefully before you start down any hill. Never go down a hill at high speed. Avoid going down a hill at an angle which would cause the vehicle to lean sharply to one side. Go straight down the hill where possible.
- Always follow proper procedures for crossing the side of a hill as described in this manual. Avoid hills with excessively slippery or loose surfaces. Never attempt to turn the UTV around on any hill. Avoid crossing the side of a steep hill if possible.
- Always use proper procedures if you stall or roll backwards when climbing a hill. To avoid stalling, maintain a steady speed when climbing a hill. If you stall or roll backwards, follow the special procedure for braking described in this manual.
- Always check for obstacles before operating in a new area. Never attempt to operate over large obstacles, such as large rocks or fallen trees. Always follow proper procedures when operating over obstacles as described in this manual.
- Always be careful of skidding or sliding. On slippery surfaces, such as ice, go slowly and be very cautious in order to reduce the chance of skidding or sliding out of control.
- Avoid operating the UTV through deep or fast flowing water. Avoid water which exceeds the recommended maximum depth. Go slowly, carefully avoiding sudden movements, maintain a slow and steady forward motion, do not make sudden turns or stops, and do not make sudden throttle changes.
- Wet brakes may have reduced stopping ability. Test your brakes after leaving water. If necessary, apply them lightly several times to let friction dry out the pads.
- Always be sure there are no obstacles or people behind you when you operate in reverse. When it is safe to proceed in reverse, go slowly. Avoid turning at sharp angles in reverse.
- Always use the size and type of tires specified in this manual. Always maintain proper tire pressure as described in this manual.
- Never modify A UTV through improper installation or use of accessories.

1. INTRODUCTION

- Never exceed the stated load capacity. Cargo should be as far forward in the bed as possible and distributed evenly from side to side. Be sure cargo is secured so that it cannot move around during operation. Reduce speed and follow instructions in this manual for carrying cargo or pulling a trailer. Allow greater distance for braking.

2. UNDERSTANDING WARNINGS

ATTENTION:

This is an ADULT VEHICLE ONLY! Not a toy!

READ AND UNDERSTAND WARNINGS AND OWNER'S MANUAL BEFORE OPERATION.



KNOW YOUR VEHICLE BEFORE YOU BEGIN RIDING!

Read this manual thoroughly referring to the various areas which are being discussed on your machine. Operating this vehicle carries with it responsibilities for your personal safety, the safety of others, and the protection of our environment.

NOTE: Illustrations used in this manual are for general representation only. Your model may differ.

2. UNDERSTANDING WARNINGS

SAFETY ALERT

WARNINGS identify special instructions or procedures which, if not correctly followed, could result in personal injury, or loss of life. Read all **WARNINGS** in this manual carefully. Follow their instructions to remain safe.

The following precautionary signal words are used throughout this manual to convey the following messages:

 This is the safety alert symbol. When you see this symbol on your machine or in this manual, be alert to the potential for personal injury. Your safety is involved!

 **WARNING**

Indicates a potential hazard which could result in severe injury or death.

 **CAUTION**

Indicates a potential hazard which may result in personal minor injury or damage to the UTV.

CAUTION

Indicates a situation that can result in damage to the machine.

NOTE The word “NOTE” in this manual will alert you to key information or instructions.

3. SAFETY WARNINGS

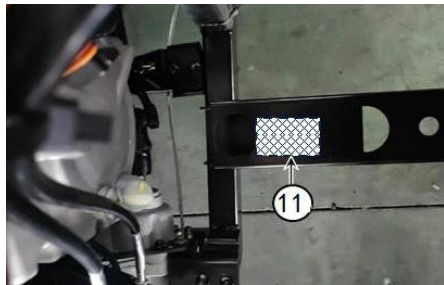
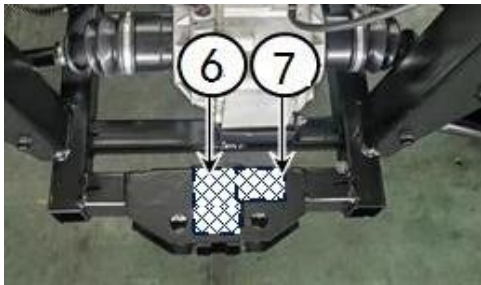

NOTE:

Warning decals have been placed on the vehicle for your protection. Read and follow the instructions on each decal carefully. In the event any decal becomes illegible or comes off, contact your dealer for a replacement.

3. SAFETY WARNINGS

1

WARNING

Improper use can result in Server INJURY or DEATH

<p>BE PREPARED</p> <ul style="list-style-type: none"> • Fasten seat belts. • Wear an approved helmet and protective gear. • Each rider must be able to sit with back against seat. <p>Feet flat on floor [and foot rests], and hands on steering wheel or handhold(s), [where equipped], Stay completely inside the vehicle.</p> <p>Drive Responsibly</p> <p>Avoid loss of control and rollovers:</p> <ul style="list-style-type: none"> • Avoid abrupt maneuvers, sideways sliding, skidding, or fishtailing, and never do donuts. • Slow down before entering a turn. • Plan for hills, rough terrain, ruts, and other changes in traction and terrain. Avoid paved surfaces. • Avoid side hilling (ride across slopes). 	<p>Be Sure Riders Pay Attention and Plan Ahead If you think or feel the vehicle may tip or roll, reduce your risk to injury:</p> <ul style="list-style-type: none"> • Keep a firm grip on the steering wheel or handholds and brace yourself. <p>Do not put any part or your body outside of the vehicle for any reason.</p> <p>Require Proper Use of Your Vehicle</p> <p>Do you part to prevent injuries:</p> <ul style="list-style-type: none"> • Do not allow careless or reckless driving. • Make sure operators are 16 or older with a valid driver's license. • Do not let people drive or ride after using alcohol or drugs. • Do not allow operation on public roads (unless designated for off-highway vehicle access)—collisions with cars and trucks can occur. • Do not exceed seating capacity; 1 passenger.
--	--

[Locate and] Read [Owner's Manual]
Follow All Instruction and Warnings
[Reserved for Reference to Other Sources of Safety Information]

ALWAYS USE AN APPROVED HELMET AND PROTECTIVE GEAR

NEVER USE PUBLIC ROADS OR PAVEMENT

NEVER USE WITH DRUGS OR ALCOHOL

2

WARNING

The enclosure cannot protect occupants in all foreseeable accidents, including rollover.

3

WARNING

IMPROPER TIRE PRESSURE OR OVERLOADING CAN CAUSE LOSS OF CONTROL. LOSS OF CONTROL CAN RESULT IN SERVER INJURY OR DEATH.

OPERATING TIRE PRESSURE: SET with tires cold. ALWAYS MAINTAIN PROPER TIRE PRESSURE AS INDICATED ON THE SIDEWALL OF YOUR VEHICLE TIRES.

NEVER set tire pressure below the recommended. Tire may dislodge from rim.

Gross Vehicle Weight Rating: 865kg (1907lbs) maximum including weight of operator, passenger, accessories, cargo, and (if applicable) trailer tongue weight.

4

WARNING

- Keep hands, body, other persons away when closing bed.
- Do not operate the vehicle with bed up.

3. SAFETY WARNINGS

5

 **WARNING**

Severe **INJURY** or **DEATH** can result if you ignore the following:

- Maximum Load in Cargo Bed: 200kg(440lbs).
- Never carry passengers in cargo bed.
- Cargo can affect handling and stability.

Read **Owner's Manual** before loading or towing.

- When loading with cargo or towing a trailer: Reduce speed and allow more room to stop. Avoid hills and rough terrain.
- Be sure cargo is secured a loose load could change handling unexpectedly.
- Keep weight in the cargo bed centered, and as low and far forward as possible. Top heavy loads increase the risk of overturn.

6

 **WARNING**

Pulling excessive loads can cause loss of stability or control of the vehicle.

Do not exceed the load capacity for the hitch.

Trailer Load Capacity of this vehicle is 450lbs /200kg and 25lbs/ 11 kg tongue weight.

7

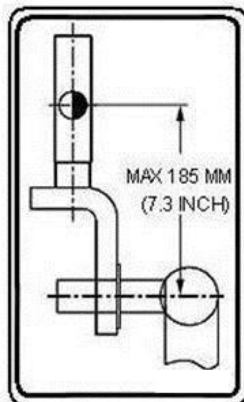

3. SAFETY WARNINGS

8

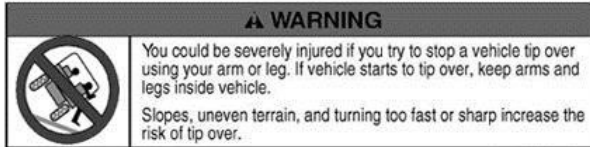
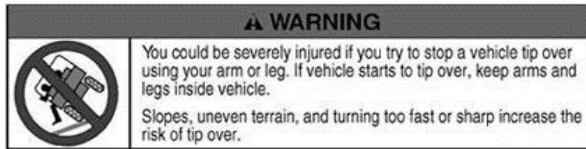

9



10

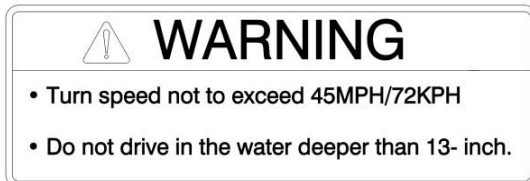

11



4. DAILY PRE-RIDE INSPECTION



WARNING

You must inspect your UTV each time before riding to ensure it is in proper working order. If a proper inspection is not done, injury or death could result.

Use the following checklist to verify your machine is in proper working order each time you ride.

ITEM/ INSPECTION PROCEDURE

1. **Tires**— check condition and pressures.
2. **Fuel tank**— check for leaks, fill the fuel tank to its proper level.
3. **All brakes** — check fluid level, check operation, adjustment (includes parking brake).

- Brake pedal

Check for correct brake pedal free play. If the brake pedal free play is incorrect, have an authorized dealer adjust it. Check the operation of the brake pedal. It should move smoothly and there should be a firm feeling when the brakes are applied. If not, have the vehicle inspected by your dealer. ● Brake fluid leakage

Check to see if any brake fluid is leaking out of the pipe joints or the brake fluid reservoir. Apply the brakes firmly for one minute. If there is any leakage, have the vehicle inspected by an authorized dealer.

Brake fluid level

- Check the brake fluid level.

Add fluid if necessary.

- Brake operation

Test the brakes at slow speed after starting out to make sure they are working properly. If the brakes do not provide proper braking performance, inspect the brake system.

4. **Throttle/ Accelerator pedal**— check for free operation, closing and freeplay.

4. DAILY PRE-RIDE INSPECTION

Check to see that the accelerator pedal operates correctly. It must operate smoothly and fully spring back to the idle position when released.

Have an authorized dealer repair as necessary for proper operation.

5. Headlight / Taillight / Brake light— check operation of all indicator lights and switches.

6. Engine stop switch— check for proper function.

7. Wheels— check for tightness of wheel nuts and axle nuts; check those axle nuts are secured by cotter pins.

Check balance/ damage/ runout. Have an authorized dealer repair/ replace if necessary.

Check bearing assemblies for looseness/damage. Have an authorized dealer replace if damaged.

8. Air cleaner element— check for dirt; clean or replace.

9. Steering— check for free operation noting any unusual looseness in any area.

Park on level ground. Turn the steering wheel right and left. Check for excessive free play, abnormal noises, or a rough feeling. Have an authorized dealer repair as necessary for proper operation.

10. Loose parts — visually inspect vehicle for any damaged components or loose nuts/bolts or fasteners.

Always check the tightness of chassis fittings and fasteners before a ride. Take the vehicle to your dealer for correct tightening torque.

11. Operator's and passenger's helmets, goggles and clothing.

12. Engine coolant— check for proper level at the recovery bottle.

4. DAILY PRE-RIDE INSPECTION

13. Seat belts— Check for proper operation and belt wear.

Make sure that both seat belts are not frayed or damaged. The seat belt must move smoothly when pulled out and retract on its own when released. The latch plate should click securely into the buckle and release when the release button is pushed firmly. Clean off any dirt or mud which could affect operation. Have an authorized dealer repair as necessary for proper operation.

5. OPERATION WARNINGS



WARNING

POTENTIAL HAZARD

Malfunction of the accelerator pedal.

WHAT CAN HAPPEN

The accelerator pedal could be hard to operate, making it difficult to speed up or slow down when you need to. This could cause an accident.

HOW TO AVOID THE HAZARD

Check the operation of the accelerator pedal before you start the engine. If it does not work smoothly, check for the cause. Correct the problem before operating the vehicle. Consult an authorized dealer if you cannot find or solve the problem yourself.



WARNING

POTENTIAL HAZARD

Not wearing the seat belt.

Wearing the seat belt improperly.

WHAT CAN HAPPEN

There is increased risk of being killed or seriously injured in an accident.

HOW TO AVOID THE HAZARD

Always wear your seat belt when riding in the vehicle.

Be sure the seat belt is close-fitting across your hips and chest and is latched securely.



WARNING

POTENTIAL HAZARD

Try to stop the tipping vehicle with your arm or leg.

WHAT CAN HAPPEN

You could be severely injured. You could suffer a crushed hand, arm, leg, or foot.

HOW TO AVOID THE HAZARD

You must keep your arms and legs inside the vehicle until it has stopped moving.

5. OPERATION WARNINGS

If you are in a situation where the vehicle is tipping over, do not put your arm and/or leg outside, do not try to stop tipping with your arm or leg. You could be severely injured. You could suffer a crushed hand, arm, leg, or foot, if part of your body is caught underneath the vehicle.



WARNING

POTENTIAL HAZARD

Pinch points.

WHAT CAN HAPPEN

You or someone else could be pinched between the cargo bed and the frame when the bed is being lowered.

HOW TO AVOID THE HAZARD

Before closing the bed, be sure others are standing away from the vehicle. Keep hands and fingers away from the pinch points between the bed and the frame.



WARNING

POTENTIAL HAZARD

Overloading the cargo bed

WHAT CAN HAPPEN

Could cause changes in vehicle handling which could lead to an accident.

HOW TO AVOID THE HAZARD

Never exceed the stated maximum load limit for this cargo bed.

Cargo should be properly distributed and securely attached.

Reduce speed when carrying cargo. Allow greater distance for braking.



WARNING

POTENTIAL HAZARD

Carrying a passenger/ passengers in the cargo bed

WHAT CAN HAPPEN

The passenger(s) could fall, be thrown out, or be struck by objects in the cargo bed.

HOW TO AVOID THE HAZARD

5. OPERATION WARNINGS

Never carry a passenger/ passengers in the cargo bed. This cargo bed is designed to carry cargo only.



WARNING

POTENTIAL HAZARD

Driving with improperly operating brakes.

WHAT CAN HAPPEN

You could lose braking ability, which could lead to an accident.

HOW TO AVOID THE HAZARD

Always check the brakes before every ride. Do not operate the vehicle if you find any problem with the brakes. If a problem cannot be corrected by the adjustment procedures provided in this manual, have the vehicle inspected by an authorized dealer.



WARNING

POTENTIAL HAZARD

Operating vehicle without being familiar with all controls.

WHAT CAN HAPPEN

Loss of control, which could cause an accident or injury.

HOW TO AVOID THE HAZARD

Read the Owner's Manual carefully. If there is a control or function you do not understand, ask your authorized dealer.



WARNING

POTENTIAL HAZARD

Overloading this vehicle or carrying or towing cargo improperly.

WHAT CAN HAPPEN

Could cause changes in vehicle handling which could lead to an accident.

HOW TO AVOID THE HAZARD

Never exceed the stated load capacity for this vehicle.

Cargo should be properly distributed and securely attached.

Reduce speed when carrying cargo or pulling a trailer. Allow greater distance for braking.

5. OPERATION WARNINGS



WARNING

POTENTIAL HAZARD

Operating this vehicle with improper modifications.

WHAT CAN HAPPEN

Improper installation of accessories or modification of this vehicle may cause changes in handling which in some situations could lead to an accident.

HOW TO AVOID THE HAZARD

Never modify this vehicle through improper installation or use of accessories. All parts and accessories added to this vehicle should be genuine parts or equivalent components designed for use on this vehicle and should be installed and used according to instructions. If you have questions, consult an authorized dealer.



WARNING

POTENTIAL HAZARD

Operating/ riding this UTV without wearing an approved helmet, eye protection and protective clothing.

WHAT CAN HAPPEN

Operating/ riding without an approved helmet increases your chances of a severe head injury or death in the event of an accident. Operating/ riding without eye protection can result in an accident and increases your chances of a severe injury in the event of an accident.

HOW TO AVOID THE HAZARD

Always wear an approved helmet which fits properly. You should also wear eye protection (goggles or face shield); gloves; boots; long-sleeved shirt or jacket; and long pants.



WARNING

POTENTIAL HAZARD

Operating this UTV after drinking alcohol or using drugs.

WHAT CAN HAPPEN

Could seriously affect your judgment.

Could cause you to react more slowly.

Could affect your balance and perception.

Could result in an accident.

HOW TO AVOID THE HAZARD

5. OPERATION WARNINGS

Never drink alcohol or use drugs before or while driving this UTV.



WARNING

POTENTIAL HAZARD

Operating this UTV at excessive speeds.

WHAT CAN HAPPEN

Increases your chances of losing control of the UTV, which can result in an accident.

HOW TO AVOID THE HAZARD

Always travel at a speed which is proper for the terrain, visibility and operating conditions, and your experience.



WARNING

POTENTIAL HAZARD

Failure to inspect the UTV before operating.

Failure to properly maintain the UTV.

WHAT CAN HAPPEN

Increases the possibility of an accident or equipment damage.

HOW TO AVOID THE HAZARD

Always inspect your UTV each time you use it to make sure the UTV is in safe operating condition.

Always follow the inspection and maintenance procedures and schedules described in the Owner's Manual.



WARNING

POTENTIAL HAZARD

Removing your hands from the steering wheel or feet from the floorboard during operation.

WHAT CAN HAPPEN

Removing even one hand or foot can reduce your ability to control the UTV or could cause you to lose your balance and fall off the UTV.

HOW TO AVOID THE HAZARD

Always keep both hands on the steering wheel and both feet on the floorboard of your UTV during operation.



WARNING

POTENTIAL HAZARD

5. OPERATION WARNINGS

Failure to use extra care when operating this UTV on unfamiliar terrain.

WHAT CAN HAPPEN

You can come upon hidden rocks, bumps, or holes, without enough time to react.

Could result in the UTV overturning or losing control.

HOW TO AVOID THE HAZARD

Go slowly and be extra careful when operating on unfamiliar terrain.

Always be alert to changing terrain conditions when operating the UTV.



WARNING

POTENTIAL HAZARD

Failure to use extra care when operating on excessively rough, slippery or loose terrain.

WHAT CAN HAPPEN

Could cause loss of traction or vehicle control, which could result in an accident, including an overturn.

HOW TO AVOID THE HAZARD

Do not operate on excessively rough, slippery or loose terrain until you have learned and practiced the skills necessary to control the UTV on such terrain.

Always be especially cautious on these kinds of terrain.



WARNING

POTENTIAL HAZARD

Turning improperly.

WHAT CAN HAPPEN

UTV could go out of control, causing a collision or overturn.

HOW TO AVOID THE HAZARD

Always follow proper procedures for turning as described in the Owner's Manual.

Practice turning at low speeds before attempting to turn at faster speeds.

Do not turn at excessive speed.

Never operate UTV on hills steeper than 15%.



WARNING

5. OPERATION WARNINGS

POTENTIAL HAZARD

Improperly operating over obstacles.

WHAT CAN HAPPEN

Could cause loss of control or a collision. Could cause the UTV to overturn.

HOW TO AVOID THE HAZARD

Before operating in a new area, check for obstacles.

Use extreme caution when riding over large obstacles, such as large rocks or fallen trees.

If you cannot avoid obstacles, always follow proper procedures as described in the Owner's Manual.



WARNING

POTENTIAL HAZARD

Skidding or sliding,

WHAT CAN HAPPEN

You may lose control of the UTV.

You may also regain traction unexpectedly, which may cause the UTV to overturn.

HOW TO AVOID THE HAZARD

On slippery surfaces, such as ice, go slowly and be very cautious in order to reduce the chance of skidding or sliding out of control.



WARNING

POTENTIAL HAZARD

Operating this UTV through deep or fast flowing water.

WHAT CAN HAPPEN

May cause electric motor failure, an electrical short circuit, or loss of control, which could lead to an accident.

HOW TO AVOID THE HAZARD

Never operate the UTV through water which exceeds the recommended maximum depth in this manual.



WARNING

POTENTIAL HAZARD

5. OPERATION WARNINGS

Operating this UTV with improper tires, or with improper or uneven tire pressure.

WHAT CAN HAPPEN

Use of improper tires on this UTV, or operation of this UTV with improper or uneven tire pressure, may cause loss of control, and increases the risk of an accident.

HOW TO AVOID THE HAZARD

Always use the size and type tires specified in the Owner's Manual for this vehicle.

Always maintain proper tire pressure as described in the Owner's Manual.



WARNING

After a rollover or an accident, have a qualified service dealer check the complete machine including, but not limited to, the brakes, throttle and steering for possible damage.



CAUTION

Keep combustible materials away from the exhaust system. Fire may result.

7. CONTROL AND PARTS FUNCTIONS

Electrical Switches Switch Panel (U.S.)

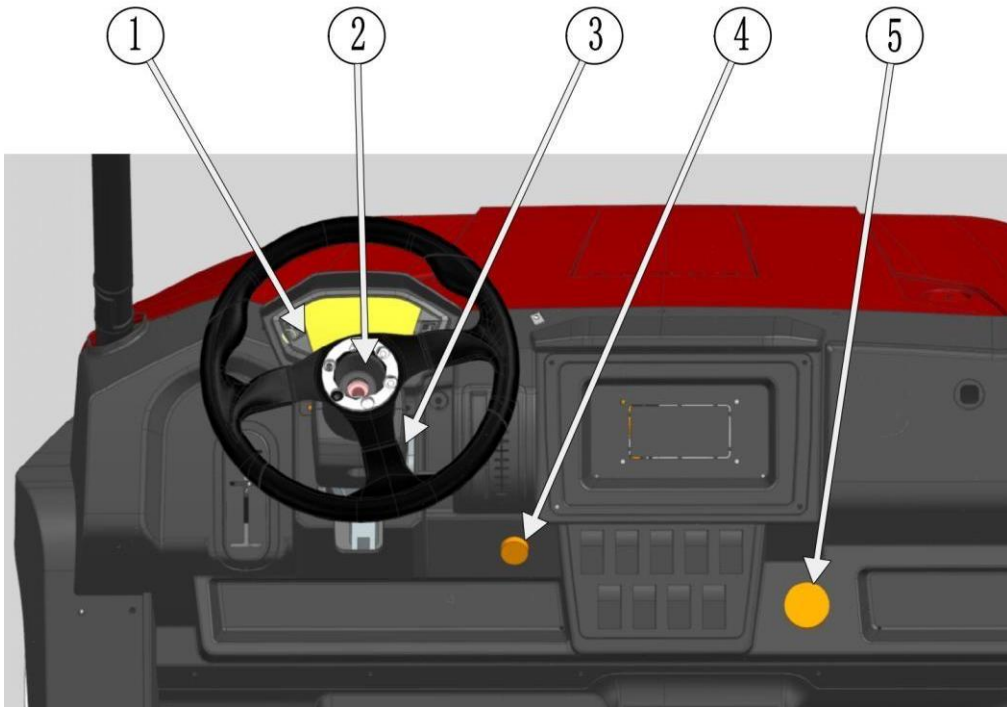

1. LCD Meter
2. Horn Switch
3. Key Switch
4. USB TYPE-C Socket
5. Accessory Socket

KEY SWITCH:

The key switch has 4 gears: Steering lock→OFF→OPEN→Ignition



CAUTION

Do not operate the electric starter continuously for more than 5 seconds, or starter damage could occur. Wait at least 5 seconds between each operation of the electric starter to let it cool.

7. CONTROL AND PARTS FUNCTIONS

Do not turn the key to the —STARTII position with the engine running, or damage to the electric starter can result.

LCD METER

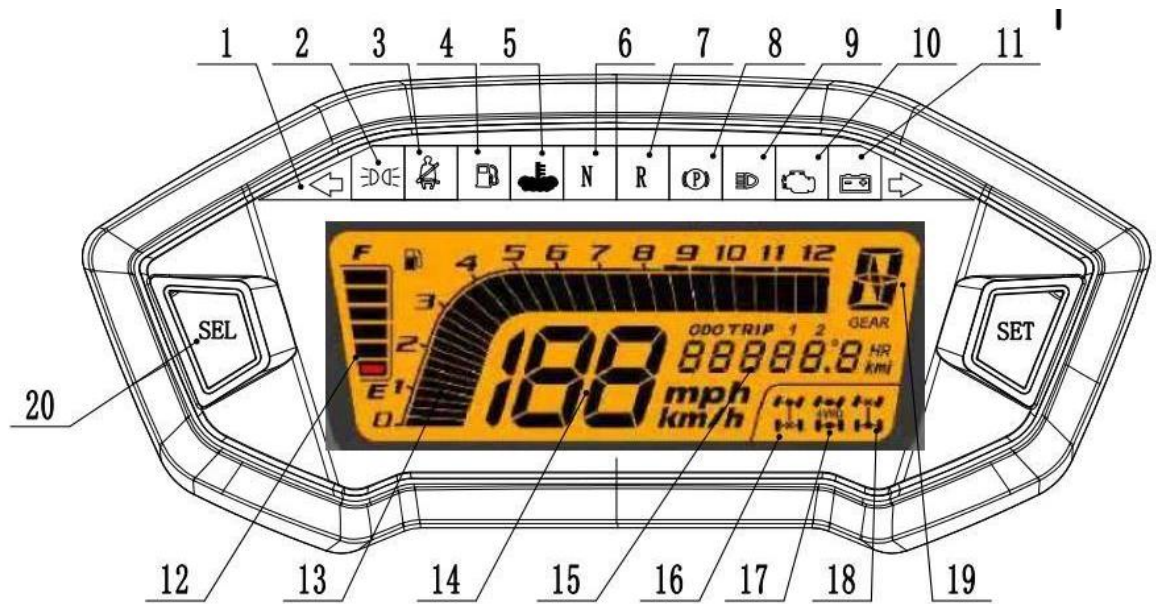

1. Left/Right Turn Indicator	11. Low battery warning
2. Headlight switch indicator	12. Fuel Gauge
3. Seat belt warning	13. Engine RPM
4. Low fuel level warning indicator	14. Speed
5. Water temperature alarm indicator	15. Odometer
6. Neutral indicator	16. Rear differential lock indicator
7. Reverse indicator	17. 2W-4W indicator
8. Parking indicator	18. Front differential lock indicator
9. High beam headlight indicator	19. Transmission position indicator
10. EFI fault indicator	20. Function buttons

7. CONTROL AND PARTS FUNCTIONS

Key function:

Function selection		Function setting			
SET NO.	Display	SET NO.	Function	SEL	Function
0	ODO				
1	Trip1			Long Press 5S	Clearing
2	Trip2			Long Press 5S	Clearing
3	Usage time				
4	Clock	Long Press 5S	Select hours	Adjust hours	
		1	Select minutes	Adjust minutes	
		2	Select mileage unit	km<-->mile	
5	Water temperature	3	Adjust Water temperature	°C <-->°F	
6	Battery voltage				
7	Backlight brightness	4	Adjust Backlight brightness	Select brightness	
8	DTC number				

7. CONTROL AND PARTS FUNCTIONS

DTC number	DTC Descriptor
P0107	Map Open/GND
P0108	Map Short V
P0112	IAT Short GND
P0117	Toil Short GND
P0118	Toil Short V Open
P0122	TPS Open GND
P0123	TPS Short V
P0131	O2 Short GND
P0132	O2 Short V
P0038	O2 heater V
P0037	O2 heater Open GND
P0201	Injector1 malfunction
P0202	Injector2 malfunction
P0231	Pump/Relay Open/GND
P0232	Pump/Relay Short to Battery
P0336	Crank sensor noisy signal
P0337	Crank sensor no signal
P0351	EST1 malfunction
P0500	VSS no valid signal
P0505	Idle speed control
P0562	System voltage low
P0563	System voltage high
P0601	EEPROM Checksum Error
P0650	MIL malfunction

INSTRUMENT FUNCTION BUTTON DETAILS:

1. Switch on the ignition, wait for electricity self-inspection of the meter, then long press the SEL button longer than 5 seconds to switch between km & miles.
2. Gently press the SEL button to switch the display between trip mileage or total mileage.

7. CONTROL AND PARTS FUNCTIONS

3. If displaying the trip mileage state, long press the SELbutton more than 3 seconds to clear the mileage value.

Caution: Electric fuel injection failure alarm indicator should be lit, when the ignition is switched on, but the engine is not started, this alarm function is normal. After the engine starts, the warning light shall be out, otherwise the EFI system has a fault.

USB TYPE-C SOCKET

- 1 USB SOCKET
- 2 TYPE SOCKET

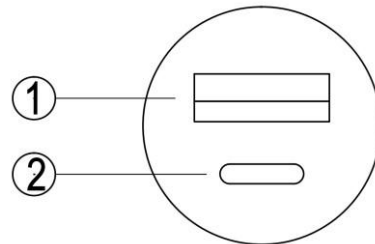

It Can provide power for appliances that support USB and TYPE-C interfaces, such as mobile phones;

Do not use appliances exceeding 100W;

When using, it is recommended to keep the engine running to prevent battery drain

7. CONTROL AND PARTS FUNCTIONS

ACCESSORY SOCKET

The accessory socket (1) is attached to the right side of the front cover. You can use the accessory socket to power a trouble light, spotlight, CB radio, or cell phone etc.

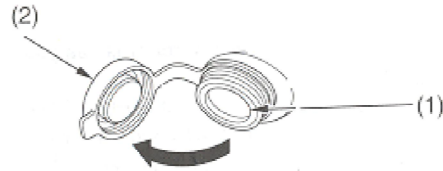

(1) accessory socket (2) cap



CAUTION

Do not plug in any heat-generating accessories such as an automobile cigarette lighter because it will damage the socket.

To use the accessory socket, start the engine. Then turn the headlights OFF and open the accessory socket cap (2).

Be sure the engine is on and the headlights are turned off before using the accessory socket, otherwise you may drain the battery.

The accessory socket rated capacity is DC 12V. 120 Watts (10A) or less.

If you exceed this limit, you may blow a fuse.

When you are done using an accessory, unplug it, and cover the socket with the cap.

Be careful not to flood this accessory socket when washing your UTV.

7. CONTROL AND PARTS FUNCTIONS

Rocker switch

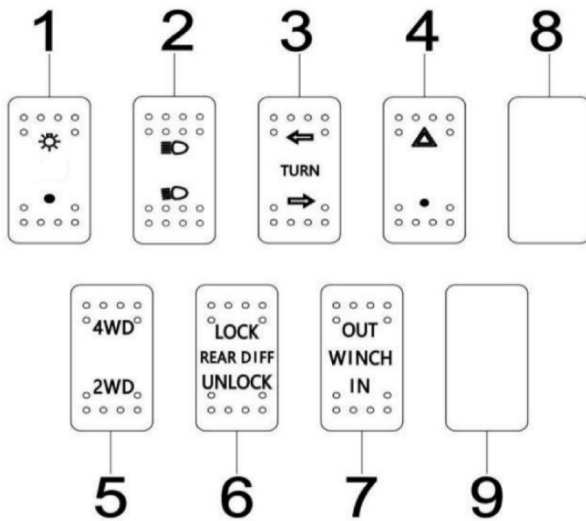

1. Light Switch: Turn on the headlights
2. Hi/ Lo Beam Switch –Switches between the high and low beam headlights.
3. Turn Signal Switch—Turns on the left/right turn signals.
4. Emergency Switch --Turns on all the turn signals.
5. 4WD Switch--Change condition of vehicle to 4WD or 2WD
6. Differential Lock Switch--For controlling the rear differential. The rear differential lock does not work when moving.
7. Winch Switch--For controlling the winch.
8. 8\9 (spare)

7. CONTROL AND PARTS FUNCTIONS

ACCELERATOR PEDAL



WARNING

Before starting the engine, check the accelerator pedal to be sure it is operating smoothly.

Make sure the accelerator pedal fully returns to the idle position as soon as it is released.

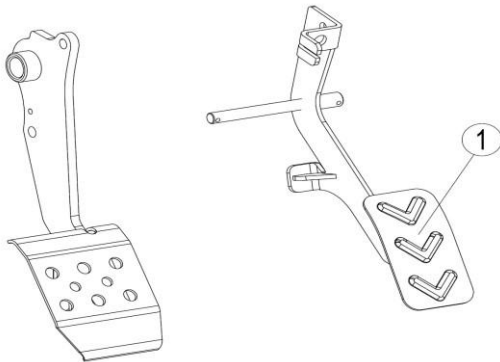

1. Accelerator pedal

Press the accelerator pedal down to increase engine speed. Spring pressure returns the pedal to the rest position when released. Always check that the accelerator pedal returns normally before starting the engine.



WARNING

POTENTIAL HAZARD

Malfunction of the accelerator pedal.

WHAT CAN HAPPEN

The accelerator pedal could be hard to operate, making it difficult to speed up or slow down when you need to.

This could cause an accident.

HOW TO AVOID THE HAZARD

Check the operation of the accelerator pedal before you start the engine. If it does not work smoothly, check for the cause. Correct the problem before

7. CONTROL AND PARTS FUNCTIONS

operating the vehicle. Consult the authorized dealer if you cannot find or solve the problem yourself.

BRAKE PEDAL

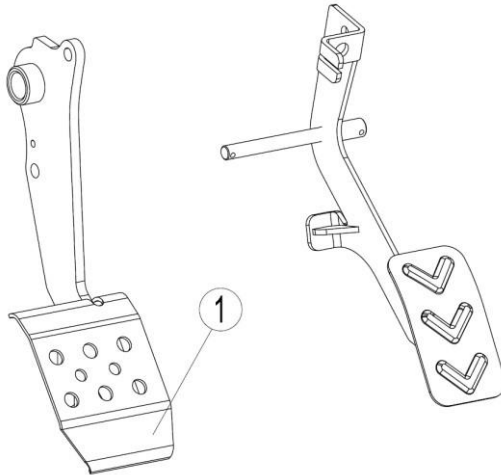

1.Brake pedal

Press the brake pedal to slow or stop the vehicle.



WARNING

Never operate the UTV with a spongy feeling brake pedal. Operating the UTV with a spongy brake pedal can result in loss of braking. Loss of braking could cause an accident.

PARKING BRAKE LEVER

The parking brake lever is located at the left-hand side of the steering wheel. It will help hold the vehicle from moving while parked. To set the parking brake, pull the lever back and down until it stops.. The parking indicator light will come on if the ignition switch is on. To release the parking brake, pull down on the lever, press the release button, and then push the lever all the way up and forward. Be

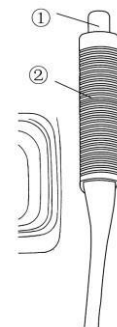

7. CONTROL AND PARTS FUNCTIONS

sure to fully release the parking brake before starting out. Failure to do so may result in poor performance and premature wearing of the parking brake and V-belt.

1. Release button
2. Parking brake lever

AUTOMATIC TRANSMISSION GEAR SELECTOR OPERATION

The transmission gear selector is located on the right side of the steering wheel. The transmission selector lever has five positions: high gear, low gear, neutral, reverse, and park.



CAUTION

To change gears, stop the vehicle and with the engine idling, move the lever to the desired gear. Shifting gears with the engine speed above idle or while the vehicle is moving could cause transmission damage. Always place the transmission in gear with the parking brake locked whenever the vehicle is left unattended. Maintaining the shift linkage adjustment is important to assure proper transmission function. Should you experience any shifting problems see your dealer for assistance.

7. CONTROL AND PARTS FUNCTIONS

FUEL TANK CAP

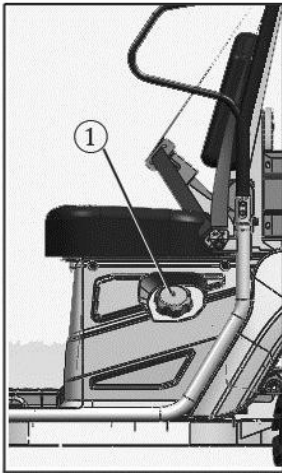

1.Fuel tank cap

Remove the fuel tank cap by turning it counterclockwise.

SEATS

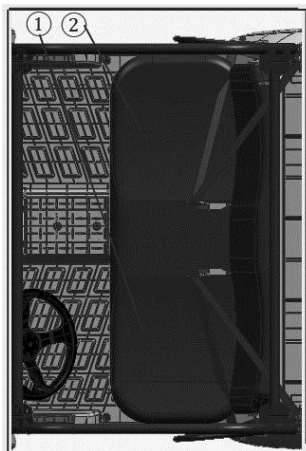

1.Driver seat

2.Passenger seat

To remove the seat, lift the front of the seat, and then slide the seat up and forward.

To install the seat, insert the projections on the rear of the seat into the seat hold slots and push down on the seat at the front. Make sure the seat lock pins engage the rubber seat bushings.

7. CONTROL AND PARTS FUNCTIONS



WARNING

POTENTIAL HAZARD

A loose seat.

WHAT CAN HAPPEN

The operator could lose control, or the operator or passenger could fall if the seat is loose during operation.

HOW TO AVOID THE HAZARD

Make sure the seat is securely latched.

SEAT BELTS

This vehicle is equipped with three-point seat belts for both the operator and passenger. Always wear the seat belt while riding in the vehicle.

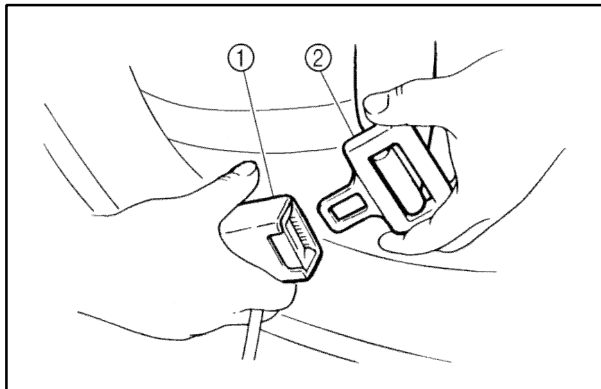

1. Buckle

2. Latch plate

7. CONTROL AND PARTS FUNCTIONS

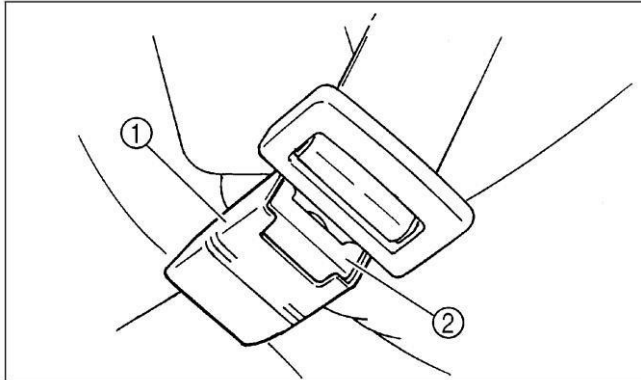

1.Buckle

2.Release button



CAUTION

To prevent damage, do not put metal products, like tools or sharp-edged products directly in the glove compartment. If they must be stored, wrap them in an appropriate cushion material or case first.

CARGO BED

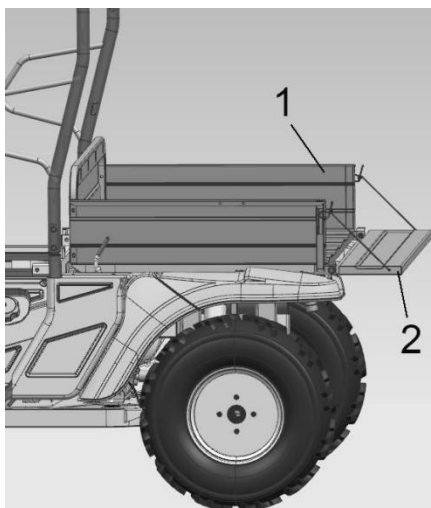

1.Cargo bed

2.Tailgate

7. CONTROL AND PARTS FUNCTIONS

Lifting and Lowering the Cargo Bed

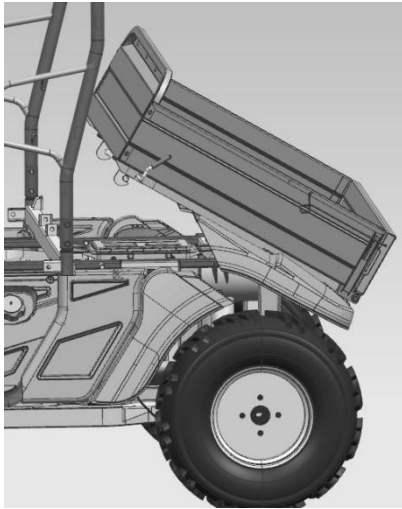

1. Cargo bed release lever

To lift:

Push down the cargo bed release lever on the left or right side of the vehicle, and then slowly lift the cargo bed until it stops.

To lower:

Lower the cargo bed slowly to its original position and be sure that it is locked into place.

7. CONTROL AND PARTS FUNCTIONS



WARNING

POTENTIAL HAZARD

Do not carry a passenger/ passengers in the cargo bed

WHAT CAN HAPPEN

The passenger(s) could fall, be thrown out, or be struck by objects in the cargo bed.

HOW TO AVOID THE HAZARD

Never carry a passenger/ passengers in the cargo bed. This cargo bed is designed to carry cargo only.

TRAILER HITCH BRACKET

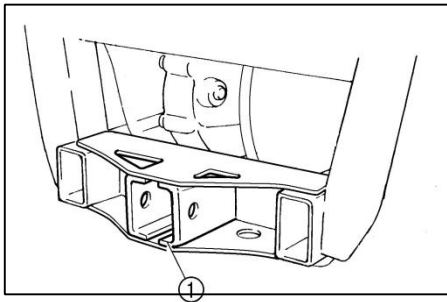

1. Trailer hitch bracket

This vehicle is equipped with a receiver bracket for a standard trailer hitch drawbar.

7. CONTROL AND PARTS FUNCTIONS

FUEL AND OIL SYSTEM



WARNING

Gasoline is highly flammable and explosive under certain conditions.

- Always exercise extreme caution whenever handling gasoline.
- Always refuel with the engine stopped and outdoors or in a well-ventilated area.
- Do not smoke or allow open flames or sparks in or near the area where refueling is performed or where gasoline is stored.
- Do not overfill the tank. Do not fill the fuel tank filler neck.
- If you get gasoline on your skin or clothing, immediately wash it off with soap and water and change your clothing.
- Never start the engine or let it run in an enclosed area. Gasoline powered engine exhaust fumes are poisonous and can cause loss of consciousness and death in a short time.



WARNING

The engine exhaust from this product contains chemicals known, in certain quantities, to cause cancer, birth defects or other reproductive harm.

Recommended Fuel: Unleaded Gasoline Only

Fuel tank capacity: 18L (4.75 Gal.)

8. STARTING THE ENGINE

Procedure for Starting a Cold Engine



WARNING

Never run an engine in an enclosed area. Carbon monoxide exhaust gas is poisonous and can cause severe injury or death. Always start engines outdoors.



WARNING

POTENTIAL HAZARD

Freezing control cables in cold weather.

WHAT CAN HAPPEN

You could be unable to control the vehicle, which could lead to an accident or collision.

HOW TO AVOID THE HAZARD

When riding in cold weather, always make sure all control cables work smoothly before you begin riding.



CAUTION

You must allow your vehicle adequate warm up time before driving, otherwise it will damage the engine.

-
1. Apply the brake.
 2. Shift the drive select lever into the neutral position.

NOTE: When the drive select lever is in the neutral position, the neutral indicator light should come on. If the neutral indicator light does not come on, ask a dealer to inspect the electrical circuit.

8. STARTING THE ENGINE

The engine can be started in any gear if the brake is applied. However, it is still recommended to shift into neutral before starting the engine.

1. With your foot off the accelerator pedal, start the engine by turning the key to "START".

NOTE: If the engine fails to start, release the key, and then try starting again. Wait a few seconds before the next attempt. Each crank should be as short as possible to preserve battery energy. Do not crank the engine more than 5 seconds on each attempt.

8. STARTING THE ENGINE

Jump-starting

Jump-starting the vehicle should be avoided. The battery should be removed and charged instead. However, if the vehicle must be jump started, proceed as follows.

1. Turn the key to "OFF".
2. Connect the positive end of a fully charged 12V battery to the positive end of battery in the car by using the jumper cable.

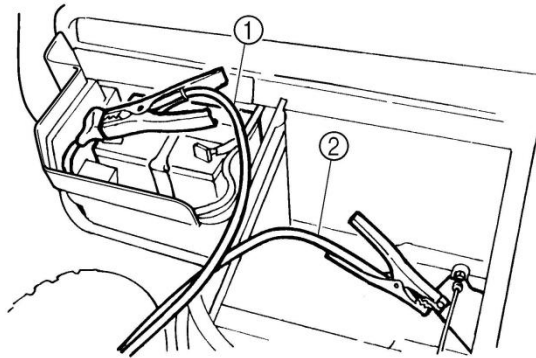

1. Jumper cable positive lead 2. Jumper cable negative lead

3. Connect the negative lead of the jumper cable to the negative terminal of the charged battery and the other end of the negative lead to an unpainted metal surface of the vehicle.
4. Turn on the ignition switch, apply the brake, turn the ignition key to start, start the engine.
5. After the engine starts, disconnect the negative lead of the jumper cable from the vehicle and charged battery, and then disconnect the positive lead of the jumper cable from the charged battery and the battery in the vehicle.

9. VEHICLE BREAK-IN PERIOD

The break-in period for your new UTV is defined as the first 25 hours of operation. No single action on your part is as important as a proper break in period. Careful treatment of the new engine will result in more efficient performance and longer life for the engine. Perform the following procedures carefully.



CAUTION

Do not operate at full throttle or high speeds for extended periods during the break-in period. Excessive heat can cause damage to engine related components.

-
1. Fill the fuel tank.
 2. Check the oil level indicated on the dipstick. Add oil if necessary.
 3. Drive slowly at first. Select an area which is open and will give you room to familiarize yourself with vehicle operation and handling.
 4. Vary the throttle positions. Do not operate at a sustained idle.
 5. Perform regular checks to the oil level, inspect all areas on the vehicle according to the chapter of "PRE-RIDE".
 6. Do not pull loads.
 7. Please replace the engine oil and filter, after driving for 25 hours or 200 miles.

9. VEHICLE BREAK-IN PERIOD

Please perform the first oil change after initial 25 hours or 200 miles of use. • Oil changes thereafter may be performed every 50 hours, 500 miles or 3 months. • Refer to oil recommendations in the maintenance section of this manual for the correct engine oil grade to use depending on the average ambient temperature / operating conditions.

- During the 25 hour initial break in period, avoid fast acceleration, operating at sustained high speeds, carrying heavy loads or towing a trailer.
- After the initial break in period, we recommend synthetic oil for oil changes, be sure to continue to use synthetic oil during services regardless of engine oil grade.

10. RIDING GEAR

Always wear clothing suited to the type of riding you are doing. UTV riding requires special protective clothing which will make you feel more comfortable and reduce chances of injury.

1. Helmet

Your helmet is the most important piece of protective gear for safe riding. Select an approved off-road motorcycle-type helmet that fits properly to prevent a severe head injury.

2. Eye Protection

A pair of goggles or helmet face shield offer the best protection for your eyes.

3. Gloves (off-road style)

4. Boots

A pair of strong over the calf type boots with heels, such as motocross boots.

5. Clothing

To protect your body, long sleeves and pants should always be worn. Riding pants with kneepads, a jersey, and shoulder pads provide the best protection.

10. RIDING GEAR



POTENTIAL HAZARD

Operating this vehicle without wearing an approved motorcycle helmet, eye protection, and protective clothing.

WHAT CAN HAPPEN

Operating without an approved motorcycle helmet increases your chances of a severe head injury or death in the event of an accident.

Operating without eye protection can result in an accident and increases your chances of a severe injury in the event of an accident.

HOW TO AVOID THE HAZARD

Always wear an approved motorcycle helmet that fits properly. You should also wear eye protection (goggles or face shield), gloves, boots, long-sleeved shirt or jacket, and long pants.

11. CARRYING LOADS

CARRYING LOADS

Cargo or a trailer can change the stability and handling of a vehicle.

You must use common sense and good judgment when carrying cargo or towing a trailer. Keep the following points in mind:

- Never exceed the weight limits shown. An overloaded vehicle can be unstable.

MAXIMUM LOADING LIMIT

Cargo bed: 200 kg (440 lbs.)

Trailer hitch:

Pulling load (total weight of trailer and cargo): 200 kg. (440 lbs.)
 Tongue weight (vertical weight on trailer hitch point): 11 kg. (25 lbs.)

- Choose a trailer hitch drawbar designed for use with a 5 cm (2 in) receiver.
- Load cargo in the cargo bed as close to the center of the vehicle as possible and tie it down using the cargo hooks equipped on the cargo bed.
- Tie down cargo securely in the trailer. Make sure cargo in the trailer cannot move around. A shifting load can cause an accident.
- Make sure the load does not interfere with controls or your ability to see where you are going.
- Drive more slowly than you would without a load. The more weight you carry, the slower you should go. Although conditions vary, it is

11. CARRYING LOADS

good practice not to exceed low range whenever you are carrying heavier loads or when towing a trailer.

- Allow more braking distance. A heavier vehicle takes longer to stop.
 - Avoid making sharp turns unless at very slow speeds.
- Avoid hills and rough terrain. Choose terrain carefully. Added weight affects the stability and handling of the vehicle.



WARNING

POTENTIAL HAZARD

Overloading this vehicle or carrying or towing cargo improperly.

WHAT CAN HAPPEN

Could cause changes in vehicle handling which could lead to an accident.

HOW TO AVOID THE HAZARD

Never exceed the stated load capacity for this vehicle. Cargo should be properly distributed and securely attached. Reduce speed when carrying cargo or pulling a trailer. Allow greater distance for braking.



WARNING

POTENTIAL HAZARD

Carrying a passenger in the cargo bed.

WHAT CAN HAPPEN

The passenger could fall or be struck by objects in the cargo bed.

HOW TO AVOID THE HAZARD

11. CARRYING LOADS

Never carry a passenger in the cargo bed. The cargo bed is designed to carry cargo only.

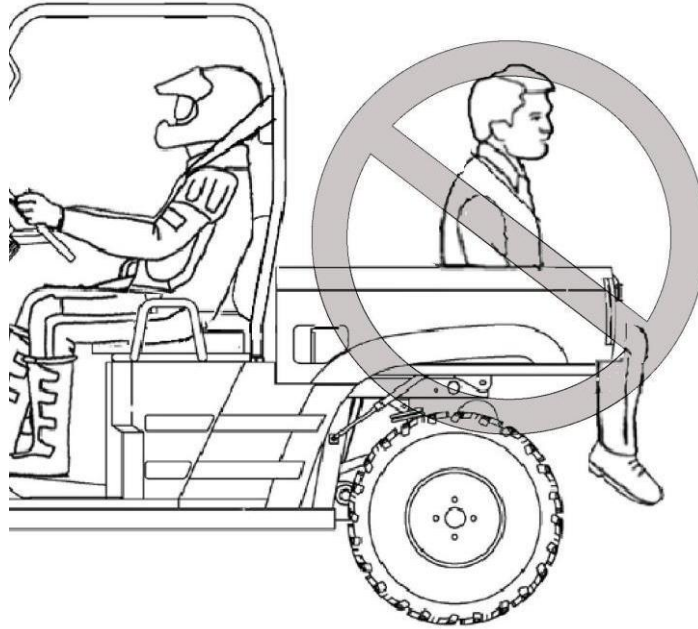

12. CVT SYSTEM



The CVT system rotates at high speeds. Creating large amounts of force on the clutch components.

Do not modify any components of the CVT system. Any modification will damage the system and cause the system to be out of balance.

The CVT housing must be securely in place during operation.

Failure to comply with this warning can result in severe injury or death.

CVT SYSTEM

On the UTV, the approximate gear ratio difference between high and low range is 1:2.2. This difference in gearing affects the operation of the

CVT, especially at speeds less than 7 MPH, due to the system's dependence on engine speed.

13. EXHAUST SYSTEM

SYSTEM REGULATION

TAMPERING WITH NOISE CONTROL SYSTEM PROHIBITED!

CAUTION: Exhaust system components are very hot during and after use of the UTV.

- Do not touch exhaust system components. Serious burns can result.
- Be especially careful when traveling through tall grass. The potential for fire exists

Spark Arrestor

The exhaust pipe must be periodically purged of accumulated carbon as follows:

1. Remove the arrestor screw ① located on the bottom of the muffler, pull out the arrestor (the mesh) ②.
2. Clean the arrestor or replace it.



WARNING

When cleaning the spark arrestor, you must follow the safeguards listed below to avoid serious injury.

- Do not perform this operation immediately after the engine has been run because the exhaust system becomes very hot.
 - Keep combustible materials away from the exhaust system, otherwise it may cause a fire.
-

13. EXHAUST SYSTEM

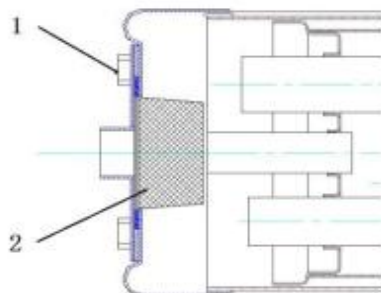

Catalyst

There is a catalyst inside the muffler on all models.



WARNING

The engine rpm limiter will work at 7500 rpm, this may cause excessive fuel to build in the exhaust, and ignited by the catalyst in the muffler, could lead to a silencer overheating and the risk of fire.

Always reduce throttle when the engine reaches top rpm, to avoid the engine popping.



WARNING

The engine exhaust from this product contains chemicals known, in certain quantities, to cause cancer, birth defects or other reproductive harm.

14.BATTERY



WARNING

Whenever removing the battery, disconnect the negative (black) cable first. When reinstalling the battery, connect the negative (black) cable last or an explosive situation could result, causing serious injury or death.



WARNING

Battery electrolyte is poisonous. It contains sulfuric acid. Serious burns can result from contact with skin, eyes, or clothing. Antidote:

External: Flush with water.

Internal: Drink large quantities of water or milk. Follow with milk of magnesia, beaten egg, or vegetable oil. Call a physician immediately.

Eyes: Flush with water for 15 minutes and get prompt medical attention.

Batteries produce explosive gasses. Keep sparks, flame, cigarettes, etc. away. Ventilate when charging or using in an enclosed space. Always shield eyes when working near batteries. KEEP OUT OF THE REACH OF CHILDREN.

Battery Removal

1. Disconnect the hold down straps holding the electrical box and battery in position and remove the battery cover.
2. Disconnect the black (negative) battery cable first.
3. Disconnect the red (positive) battery cable next.
4. Lift the battery out of the UTV.



CAUTION

If electrolyte spills, immediately wash it off with a solution of one tablespoon baking soda and one cup water to prevent damage to the UTV.

14.BATTERY

Battery Installation and Connections



WARNING

To avoid the possibility of explosion, always connect the battery cables in the order specified. Red (positive) cable first; black (negative) cable last. An exploding battery can cause serious injury or death.



WARNING

Battery terminals and connections should be kept free of corrosion. If cleaning is necessary, remove the corrosion with a stiff wire brush. Wash with a solution of one tablespoon baking soda and one cup of water. Rinse well with tap water and dry off with clean rags. Coat the terminals with dielectric grease or petroleum jelly. Be careful not to allow cleaning solution or tap water into the battery.

1. Set the battery in its holder.
2. First, connect and tighten the red (positive) cable.
3. Second, connect and tighten the black (negative) cable.
4. Reinstall battery cover and attach the hold down strap.
5. Verify that cables are properly routed.



CAUTION

Your UTV is equipped with a 30Ah Battery. This may not be sufficient to provide power for optional equipment. When installing optional equipment please upgrade your battery, as necessary. See your dealer for the proper battery.

15. TROUBLESHOOTING

LOW BATTERY

Possible Cause	Solutions
Starting a faulty engine for a long time	See "8. STARTING THE ENGINE" And check the fuel/ air/ ignition/ compression system
Left the ignition switch (key) on while parking the UTV	When stopping the engine, turn off the ignition switch (key) off at once



WARNING

This UTV is equipped with an electric start system. If the battery is under charging, the UTV will not run.

NOTE:

The following troubleshooting does not cover all the possible causes of trouble. It should be helpful, however, as a guide to troubleshooting. Refer to the relative procedure in this manual for inspection, adjustment, and replacement of parts. Adjustment and replacement must be done by your dealer.

STARTING FAILURE/ HARD STARTING

FUEL SYSTEM

Fuel tank

- Empty
- Clogged fuel tank breather hole
- Fuel pump is clogged

15. TROUBLESHOOTING

- Deteriorated fuel or fuel containing water or foreign materials

Electric fuel injection

- ECU failure or wiring faulty
- Nozzle clogging or failure
- Throttle position sensor failure
- EFI relay does not work

COMPRESSION SYSTEM

Cylinder and cylinder head

- Loose spark plug
- Loose cylinder head
- Broken cylinder head gasket
- Broken cylinder gasket
- Worn, damaged or seized cylinder

Piston and Piston ring

- Worn piston
- Worn fatigued or broken piston ring
- Seized piston ring
- Seized or damaged piston

Valve system

- Improperly adjusted valve clearance
- Improperly sealed valve
- Improperly contacted valve and valve seat
- Improper valve timing
- Broken valve spring

IGNITION SYSTEM

Battery

- Improperly charged battery
- Faulty battery

Fuse

- Burnt out, improper connection

Spark plug

Ignition system

- Faulty ignitor unit
- Faulty pick up coil
- Broken magneto woodruff key

Switch

15. TROUBLESHOOTING

- Improper plug gap
- Worn electrodes
- Wire between terminals broken
- Faulty main switch
- Faulty brake switch

- Improper heat range
- Faulty spark plug cap

Ignition coil

- Broken or shorted primary/
secondary coil
- Faulty high-tension cord
- Broken ignition coil body

Wiring

- Loose battery terminal
- Loose coupler connection
- Improperly grounded
- Broken wire harness

POOR IDLE SPEED PERFORMANCE

EFI

- Loose or clogged pilot jet
- Trigger coil gap inappropriate
- Ignition loop cable failure
- Improperly adjusted idle speed
(Pilot screw), (Throttle stop screw)
- Improperly adjusted throttle cable
- Intake pressure temperature sensor failure

Air cleaner

- Clogged air cleaner
element

Ignition system

- Faulty spark plug
- Faulty high-tension cord
- Faulty ignition coil

Valve system

- Improperly adjusted
-

15. TROUBLESHOOTING

POOR MEDIUM AND HIGH-SPEED PERFORMANCE

EFI

- Improperly adjusted fuel level
- Clogged air cleaner element
- Clogged main nozzle

Air cleaner

POOR SPEED PERFORMANCE

Ignition system

- Dirty spark plug
- Improper heat range
- EFI failure

Fuel system

- Clogged fuel tank breather hole
- Clogged air cleaner element
- Clogged jet
- Improperly adjusted fuel level
- Improper carburetor air vent hose setting

Compression system

- Worn cylinder
- Worn or seized piston ring
- Cylinder head gasket broken
- Cylinder gasket broken

- Carbon deposit buildup
- Improper adjusted valve clearance
- Improper contacted valve and valve seat
- Faulty valve timing

Clutch

- Refer to "CLUTCH SLIPPING /DRAGGING" section

Engine oil

- Improper oil level (low or over Oil level)

Ignition system

15. TROUBLESHOOTING

- Faulty spark plug
- Faulty high-tension cord
- Faulty pick up coil
- Faulty ignition coil

Valve system

- Improperly adjusted valve clearance

OVER HEATING

Ignition system

- Improperly spark plug gap
- Improper spark plug heat range
- Faulty igniter unit

OVER-COOLING

Cooling system

- Faulty temperature switch
 - Water temperature regulation set incorrectly

Fuel system

- ECU setting incorrectly
- Improper fuel level adjustment
- Clogged air cleaner element

Compression system

- Heavy carbon deposit build-up
- Improperly adjusted valve timing
- Improperly adjusted valve clearance

Engine oil

- Incorrect engine oil level
- Improper engine oil quality (High viscosity)

15. TROUBLESHOOTING

- Low engine oil quality

Brakes

- Dragging brake

Cooling system

- Radiator temperature sensor failure
- Radiator fan failure

FAULTY CLUTCH

WITH ENGINE RUNNING, UTV DOES NOT MOVE

V belt

- Worn/bent/slipping

Cam, slider

- Worn/damaged

Compression spring

- Damage

Gears

- Damage

CLUTCH SLIPPING

Clutch weight spring

Position

- Worn/loose

Clutch shoe

- Worn/ damaged

Primary sliding sheave

- Seized

POOR STARTING

POOR SPEED PERFORMANCE

V-belt

- Worn
- Oily V belt

Roller weight

- Worn/improper operation
primary/secondary/sheave

- Worm

CVT SYSTEM

Incorrect Primary Clutch

- Incorrect engine mount
(see 13. CVT system)

FAULTY BRAKE

15. TROUBLESHOOTING

PERFORMANCE

V-belt

- Slipping/oily V-belt

Primary sliding sheave

- Improper operation
- Damage

compressing spring

- Worn/loose

Secondary sliding sheave

- Improper operation
- Worn guide pin groove
- Worn guide pin

Clutch shoe

- Worn/

POOR BRAKING EFFECT

- Worn front hub bearing
- Worn brake pad
- Worn brake disc
- Air in brake fluid
- Leaking brake fluid
- Faulty master cylinder kit
- Faulty caliper seal kit
- Loose union bolt
- Broken brake hose
- Oily or greasy brake pad
- Oily or greasy brake disc

16.SPECIFICATIONS

Dimensions & Capacities			
L X W X H	2623X1480X1940 mm		
Seat height	470mm		
Wheelbase	1880mm		
Ground Clearance	260mm		
Fuel capacity	18L (4.75 Gal.)		
Engine Oil Capacity	1.3 L		
Dry Weight	540 kg		
Load Capacity (Combined Rider & Payload)	350 kg (770 lbs.)		
Cargo Bed Maximum load limit	200kg (440 lbs.)		
Tow Capacity	362.9 kg (800 lbs.)		
Drive System			
Drive System	CVT		
Front Tire	25X8-12		
Rear Tire	25X10-12		
Tire Pressure(front)	138 kPa (20 PSI)		
Tire Pressure(rear)	138 kPa (20 PSI)		
Brake System			
Brake	Front Brake	Dual Hydraulic Disc	Front and rear unified
	Rear Brake		
	Operation	Foot	
Parking Brake	Mechanical Disc		
Suspension			
Front	MacPherson Strut		
Rear	Swing Arm		
shock absorber	Coil spring/oil damper		

16.SPECIFICATIONS

Engine	
Engine Type	XY182MQ 4Stroke, Single Cylinder, SOHC
Bore x Stroke	82mmx74mm
Displacement	390.8cc
Starter System	Electric Starter
Engine Cooling	Liquid -Cooled
Lubrication System	Wet Sump
Ignitions	EFI
Spark Plug Type	DR8EA

16.SPECIFICATIONS

Electrical Equipment			
Battery		12V 30AH	
Head light		LED	
Front Position Light		LED	
Rear Position Light		LED	
Brake/ Tail Light		LED	
Parking Light		LED	
High Beam Indicator Light		LED	
Neutral Indicator Light		LED	
Reverse Indicator Light		LED	
Specified fuses	Main Fuse	40 A	On the Start Relay
	Relay fuse	10 A	In the Fuse Box
	Light/Meter fuse	20 A	
	EFI fuse	10 A	
	Fan fuse	20 A	
	Axles fuse	15 A	
	Accessories fuse	20 A	
	Optional System fuse	25 A	
	Spare fuses	20A	
	Spare fuses	15A	

17. WIRING DIAGRAM

Note	Colour
B	Black
B/Y	Black/Yellow
B/R	Black/Red
B/G	Black/Green
B/W	BLACK/White
Bl	Blue
Bl/W	Blue/White
Bl/Y	Blue/Yellow
Bl/B	Blue/Black
Bl/Br	Blue/Brown
Bl/Gr	Blue/Gray
Bl/R	Blue/Red
Br	Brown
Br/G	Brown/Green
Br/R	Brown/Red
Br/Bl	Brown/Blue
Br/B	Brown/Black
Br/R	Brown/Red
D G	Dark Green
D G/R	Dark Green/Red
G	Green
G/B	Green/Black
G/Y	Green/Yellow
G/Gr	Green/Gray
G/R	Green/Red
Gr	Gray
Gr/R	Gray/Red

Note	Colour
G/W	Green/White
Gr/G	Gray/Green
Gr/W	Gray/White
Gr/B	Gray/Black
L G	Light Green
L Bl	Light Blue
Or	Orange
Or/R	Orange/Red
P	Pink
P/W	Pink/White
P/B	Pink/Black
P/Y	Pink/Yellow
P/Bl	Pink/Blue
Pu/W	Purple/White
Pu	Purple
R	Red
R/Bl	Red/Blue
R/W	Red/White
W	White
W/R	White/Red
W/Or	White/Orange
W/Br	White/Brown
Y	Yellow
Y/R	Yellow/Red
Y/B	Yellow/Black
Y/G	Yellow/Green
Y/W	Yellow/White

17. WIRING DIAGRAM

Power Distribution & Engine Starting System

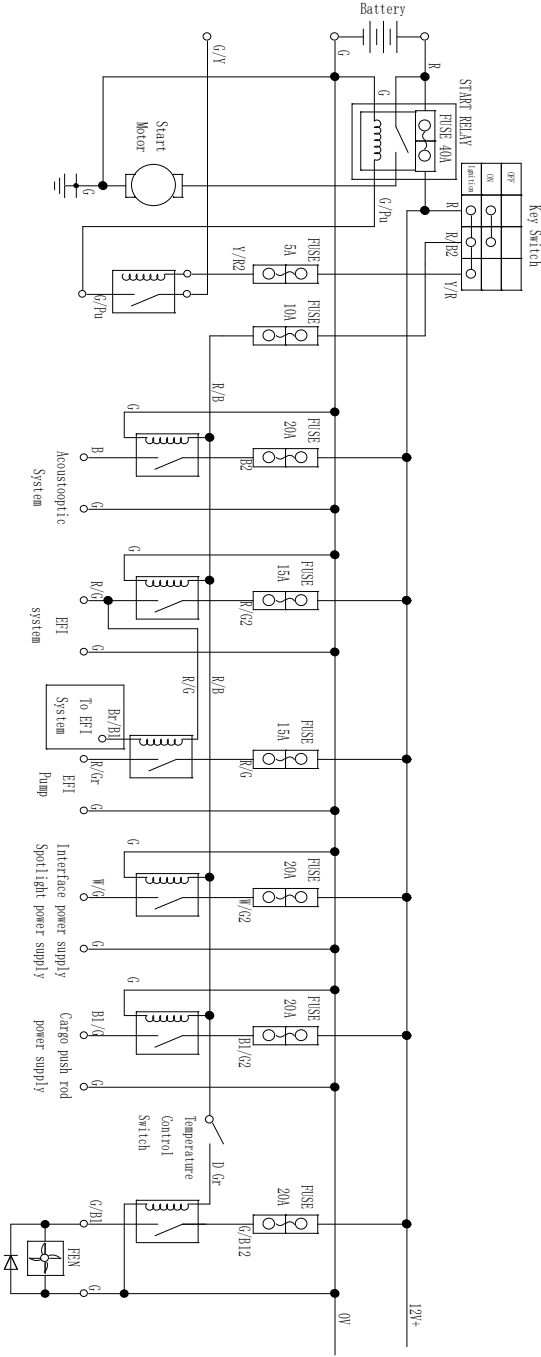

17. WIRING DIAGRAM

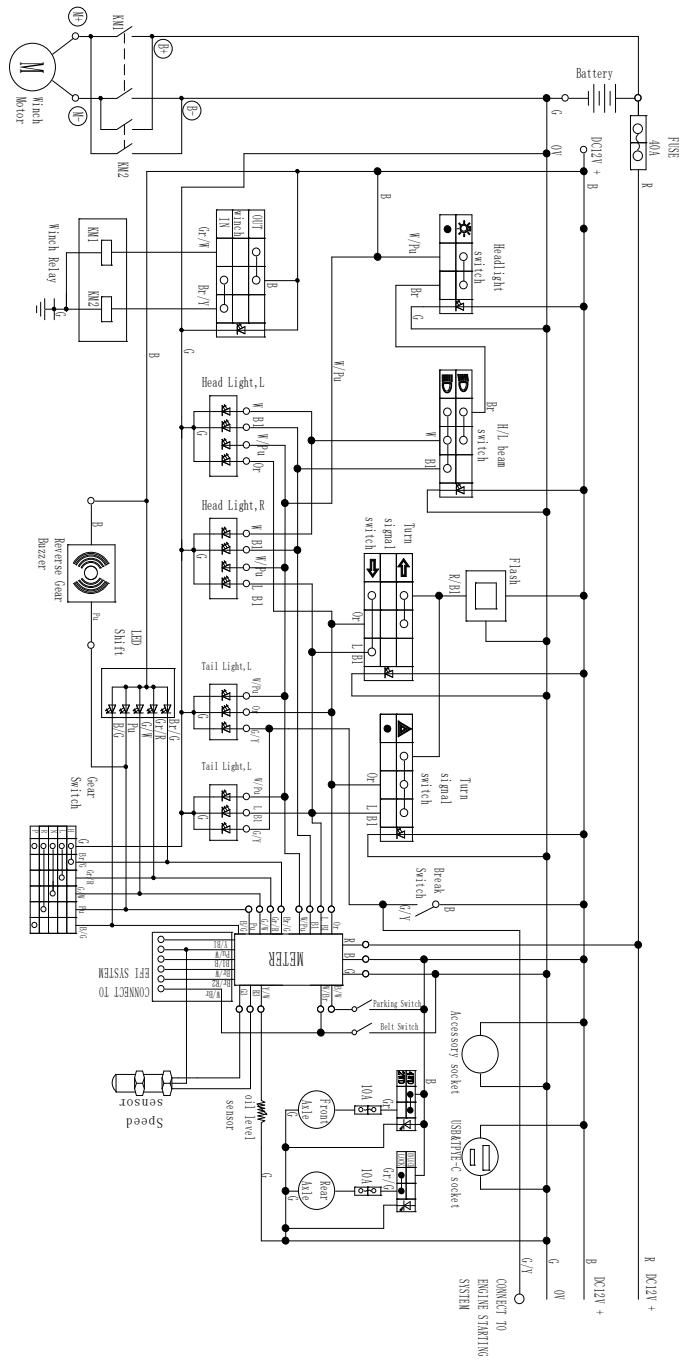

Acoustoptic System

17. WIRING DIAGRAM

FBI System & Engine Start

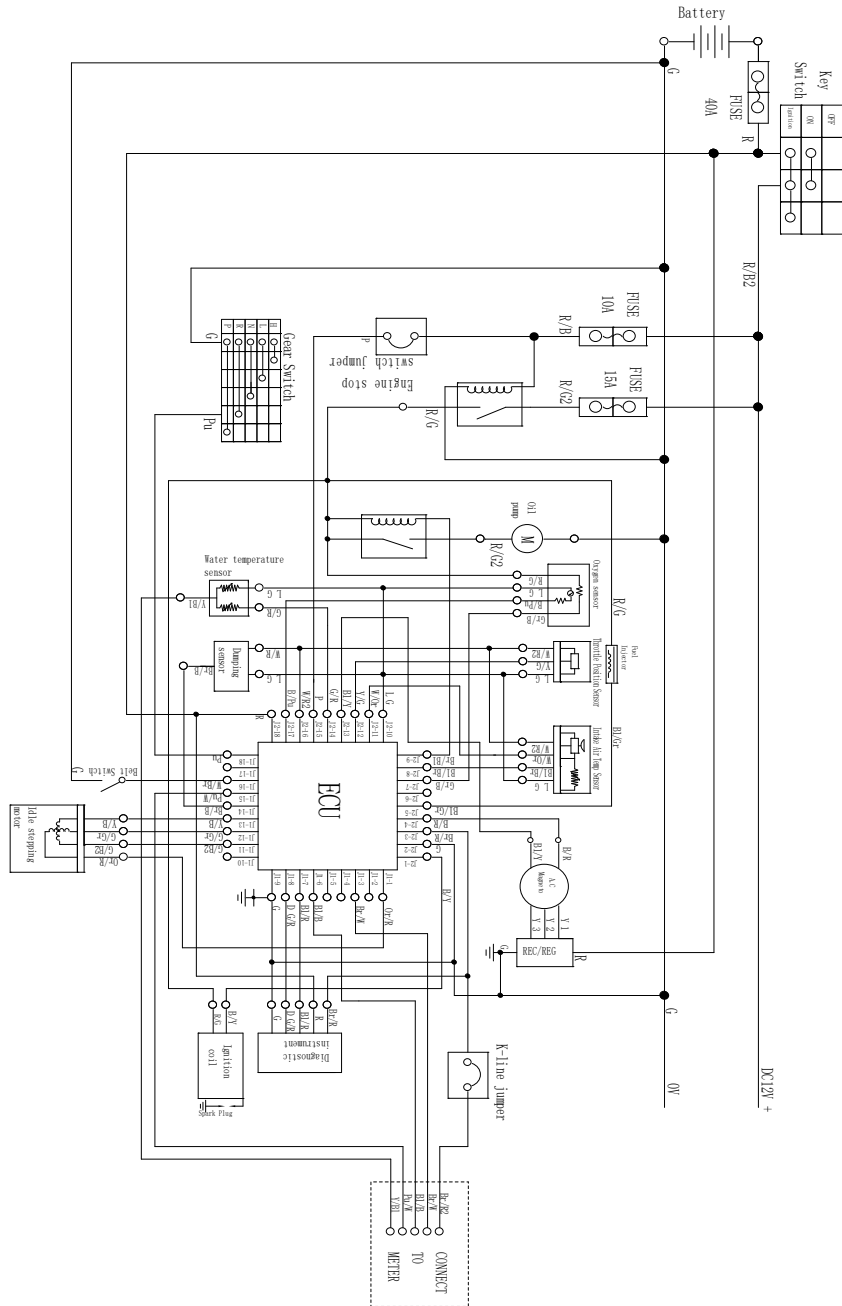

17. WIRING DIAGRAM

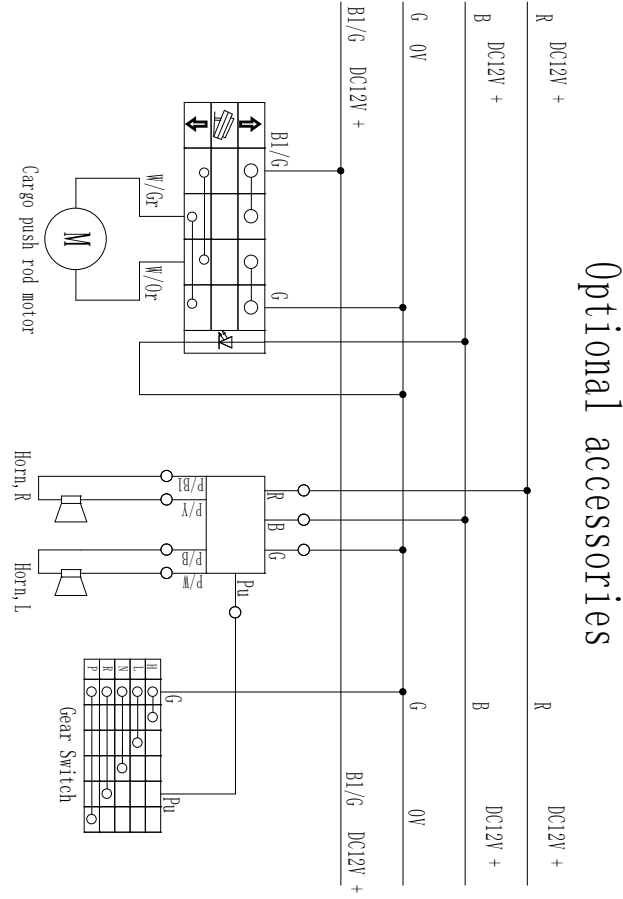

18. MAINTENANCE

To keep the performance good, the vehicle should be checked and maintained at certain intervals.

The meanings of capital in following table are:

I: Inspection, including check, clean, lubricate, refuel, repair or replacing if necessary.

A: Inspection, adjusting if necessary C: Cleaning R: Replacing

L: Lubricate

Maintenance period Items	Odometer KM – (MILES)						
	750 (500)	3000 (1900)	6000 (3800)	9000 (5600)	12000 (7500)	15000 (9400)	Everyday check before riding
Re-seating Valve		I	I	I	I	I	
Spark Plug		I	R	I	R	I	
Fuel System		I	I	I	I	I	
Engine Oil	R	R	R	R	R	R	I
Valve Gap		A	A	A	A	A	
Idle Speed		A	A	A	A	A	
Engine Bolt		I	I	I	I	I	
Gear Oil		R	R	R	R	R	
Fuel Filter		R	R	R	R	R	
Air Cleaner		C	R	C	R	C	
Drive Belt		I/L	I/L	I/L	I/L	I/L	
Cooling System		I	I	I	I	I	
Engine Mount		I	I	I	I	I	
Fuel Line		I	I	I	I	I	
Throttle Operation		I	I	I	I	I	
Brake Shoes/Pad Wear		I	I	I	I	I	
Brake System		I	I	I	I	I	
Brake Light Switch		I	I	I	I	I	
Brake Liquid		I	I	I	I	I	
Clutch		I	I	I	I	I	
Suspension		I	I	I	I	I	
Nuts,Bolts,Fasteners		I	I	I	I	I	
Wheel/Trye		I	I	I	I	I	
Steering System		I	I	I	I	I	

18. MAINTENANCE

The following items should be checked occasionally for tightness; or if they have been loosened for maintenance service. **WHEEL NUT TORQUE SPECIFICATIONS**

Bolt Size	Specification	
M12X1.25	50 Ft.Lbs	69N.m

NOTE: All nuts that have a cotter pin installed must be serviced by an authorized Dealer.

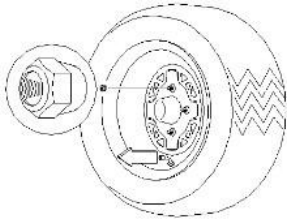

AXLE BOOTS

- Front Shaft Boots,
- Rear Axle (CV Joints,) Boots,

Check the protective boots for holes or tears. If any damage is found, have them replaced by an authorized dealer.

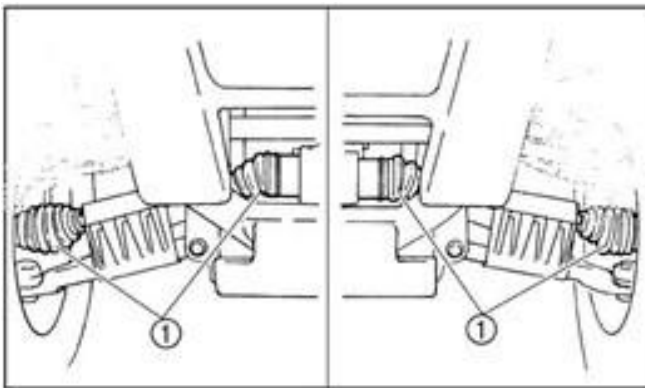

REAR SPRING ADJUSTMENT

The rear shock absorber spring is adjusted by rotating the adjuster in the direction required to increase or decrease spring tension.

18. MAINTENANCE

Rear Spring
Adjustment

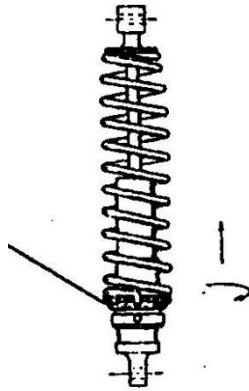

AIR FILTER SERVICE

1. Lift the cargo bed. (See 7. CONTROL AND PARTS FUNCTIONS in this manual for bed lifting and lowering.)
2. Release clips and remove Cover.
3. Loosen clamp and remove Filter.
4. Remove fabric type pre-filter from main filter. Wash the pre-filter in soapy water and dry it.
5. Reinstall pre-filter over main filter. Replace main filter as required.
6. Reinstall filter into air box and tighten clamp. Do not over tighten clamp, otherwise filter damage may occur.

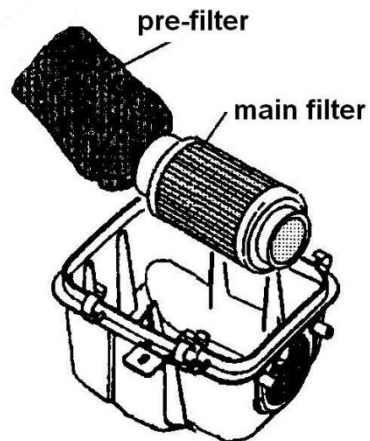

18. MAINTENANCE

STEERING

Steering Inspection

The steering assembly of the machine should be checked periodically for loose nuts and bolts, worn tie rod ends, worn boots, and damage. Checking routing of all cables, hoses, and wiring to be sure the steering mechanism is not restricted or limited. If any problems are found, have your dealer repair them before riding your vehicle.

The steering assembly should be also checked periodically for free operation, steering should move freely through the entire range of travel without binding. Park on level ground. Turn the steering wheel right and left. Check for excessive free play, abnormal noises, or a rough feeling. Have an authorized dealer repair as necessary for proper operation.

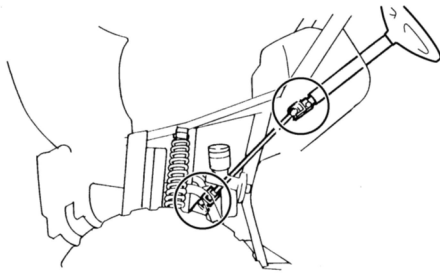

Lubricate the pivoting parts.

Recommended lubricant:

Lithium-soap-based grease

CAMBER AND CASTER

The camber and caster non-adjustable.

TOE ALIGNMENT CHECK



WARNING

are

Do not attempt to adjust the tie rod for toe alignment. Severe injury or death can result from improper adjustment.

Contact your dealer. They have the training and tools necessary to make these adjustments.

18. MAINTENANCE

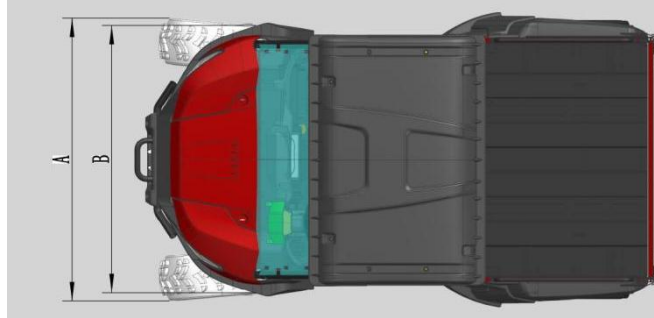

The recommended toe alignment is 1/8" to 1/4" (3 to 6mm) toe in.

1. Set the steering wheel in a straight-ahead position and hold them in this position.
2. Measure A and B, A minus B should be 1/8" to 1/4" (3 to 6mm).
3. If this measurement needs to be adjusted, contact your dealer for service.



WARNING

If the tie rod is positioned incorrectly or adjusted incorrectly, it will not pivot, may break, and may separate. Severe injury or death can result.

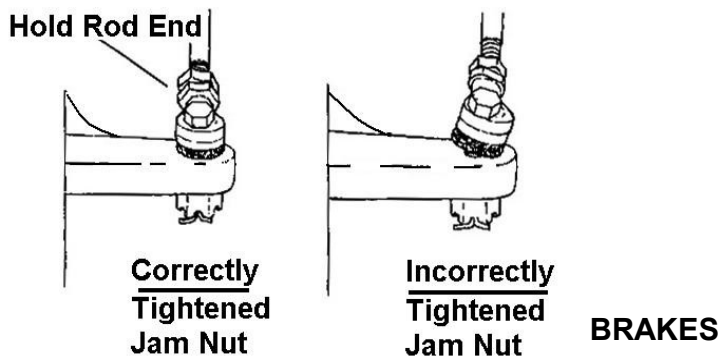

- Always fill the reservoir as indicated whenever the cover is loosened or removed to ensure proper diaphragm operation. Use DOT 3 brake fluid.
- Check the brake system for fluid leaks.
- Check the brake for excessive travel or a spongy feeling.

18. MAINTENANCE

- Check friction pads for wear, damage and looseness.
- Check the surface condition of the brake rotor.
- Pads should be changed when friction material is worn to 3/64" (1mm). (A)

Checking the brake fluid level

Insufficient brake fluid may let air enter the brake system, possibly causing the brakes to become ineffective. Before riding, check that the brake fluid is

above the minimum level mark and replenish if necessary. A low brake fluid level may indicate worn brake pads and/or brake system leakage. If the brake fluid level is

low, be sure to check the brake pads for wear and the brake system for leakage.



- The brake fluid reservoir is located under the hood.
- When checking the fluid level, make sure the top of the brake fluid reservoir is level.
- Use only the recommended quality brake fluid. Otherwise, the rubber seals may deteriorate, causing leakage and poor braking performance.

Recommended brake fluid: DOT 3

- Refill with the same type of brake fluid. Mixing fluids may result in a harmful chemical reaction and lead to poor braking performance.
- Be careful that water does not enter the brake fluid reservoir when refilling. Water will significantly lower the boiling point of the fluid and may result in vapor lock.
- Brake fluid may deteriorate painted surfaces or plastic parts. Always clean up spilled fluid immediately.

18. MAINTENANCE

- Have an authorized dealer inspect the brake system if the brake fluid level goes down.

Brake pedal and accelerator pedal lubrication

Lubricate the pivoting parts.

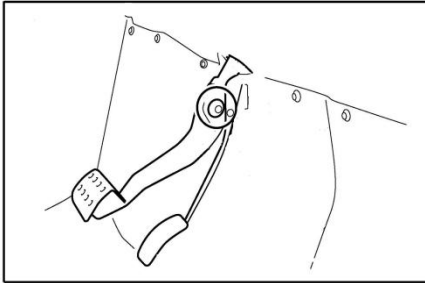

Recommended lubricant:
Lithium-soap-based grease
(all-purpose grease)

PARKING BRAKE

Checking

Although the parking brake has been adjusted at the factory, the brake

should be checked for proper operation. The mechanical brake must be maintained to be fully functional.

1. With the engine off, apply the parking brake lever and attempt to move the UTV.
2. If the rear wheels are locked, it is adjusted properly.
3. If the wheels are not locked, it must be adjusted.

Adjusting

To adjust the mechanical parking brake, use the following procedure:

Note: The adjustment on the caliper is for the wear out of the pads.

1. With the engine off, loosen the adjuster on the lever.
2. Loosen the jam nut of the adjuster on the caliper.
3. Turn the adjuster (bolt) CW (clockwise) by hand till the pads touch the brake disc, turn the adjuster bolt CCW (counterclockwise) by 1/4 to one turn for 10-20mm free play at the end of the parking lever.
4. Tighten the jam nuts securely against the adjusters.
5. Make sure the rear wheels turn freely without dragging.
6. Turn the adjuster (the one on the lever) and apply the lever. While adjusting, it is important you move the lever back and forth for operation, free play and the locking of the parking position.

18. MAINTENANCE

7. Make sure the rear wheels turn freely without dragging and the parking brake works properly.
8. Field test for parking. It must be capable of holding the laden UTV stationary on an 18% gradient.

A temporary adjustment can also be done to the brake cable on the parking lever side by turning the adjuster (nut) directly. But the adjusted range is limited. Always do **procedure 1 to 8** when necessary.

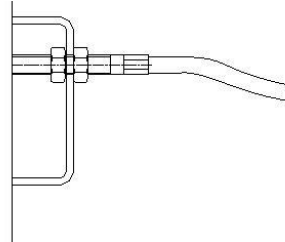

Throttle Free Play Inspection

1. Apply the parking brake.
2. Put transmission in the Neutral position.
3. Start the engine, and warm it up thoroughly.
4. Measure the distance the throttle pedal moves before the engine begins to pick up speed. Free play should be 1/16" to 1/8" (1.5-3mm).

Throttle Free Play Adjustment Throttle cable free play is adjusted at the cable, under the passenger seat.

1. Slide the boots off. Loosen the adjuster lock nut.
2. Turn adjuster until 1/16" to 1/8" (1.5 to 3mm) freeplay is achieved at the throttle pedal. **NOTE:** While adjusting free play it is important you flip the throttle pedal back and forth.

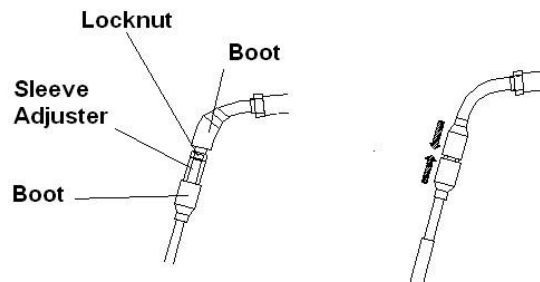

3. Tighten locknut and slide the boots over the cable adjuster.

18. MAINTENANCE

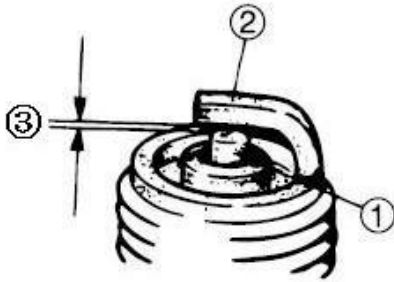

SPARK PLUGS

Inspect: •

Insulator ①

Abnormal color: Replace.

Normal color is a medium-

to-light tan color. • Electrode ②

Wear/damage: Replace.

- Clean spark plug use spark plug cleaner or wire

Standard spark plug: DR8EA (brush)

Measure:

③ Gap: 0.8mm

- Spark plug gap ③

Out of specification: Adjust gap.

Spark Plug Removal and Replacement



WARNING

Never attempt to remove a spark plug while the engine is warm. The exhaust system or engine could burn you causing severe injury.

Remove the spark plug by rotating counterclockwise.

Reverse the procedure for spark plug installation.

Torque to 17 ft.Lbs (23N.m).

18. MAINTENANCE

If you want to know more about maintenance details, please refer to the following table.

Due to the nature of the adjustments marked with a **D** on the following chart, it is recommended these services be performed by an authorized dealer.

- More often under severe use, such as dirty or wet conditions to purge water or dirt contamination from grease fittings and other critical components.

PERIODIC MAINTENANCE SCHEDULE

Careful periodic maintenance will help keep your vehicle in the safest, most reliable condition. Inspection, adjustment and lubrication intervals of important components are explained in the following chart on the following pages.

NOTE:

Maintenance intervals are based upon average riding conditions and an average vehicle speed of approximately 16 km/h. However, keep in mind that if the vehicle is not used for a long period of time, the month maintenance intervals should be followed.

Vehicles subjected to severe use, such as operation in wet or dusty areas, should be inspected and serviced more frequently.

Inspect, clean, lubricate, adjust, or replace parts, as necessary.

NOTE:

Inspection may reveal the need for replacement parts. Always use genuine parts available from your dealer.

Service and adjustments are critical. If you are not familiar with safe service and adjustment procedures, ask a qualified dealer to perform these operations

18. MAINTENANCE

	Item	Hours	When	Remarks
●	Brake System	Pre-ride	Pre-ride	Pre-ride inspection item
	Accelerator pedal	Pre-ride	Pre-ride	Inspect –adjust, lubricate, replace if necessary; pre-ride inspection item
	Fuel System	Pre-ride	Pre-ride	Check for leaks at tank cap, lines, fuel valve, filter, and carburetor.
●	Tires	Pre-ride	Pre-ride	Inspect daily, pre-ride inspection item
●	Front and Rear Wheels/ Hubs	Pre-ride	Pre-ride	Pre-ride inspection item
●	Steering	Pre-ride	Pre-ride	Inspect daily, lubricate
D	Wheels bearings	10 hrs	Monthly	Check for looseness/ damage. Replace if damaged.
	Frame nuts, bolts fasteners	Pre-ride	Pre-ride	Pre-ride inspection item
●	Air Filter-Pre-Cleaner	Daily	Daily	Inspect-Clean
	Coolant/Level Inspection	Daily	Daily	Replace engine coolant every year
●	Air Box Sediment Tube	Daily	Daily	Drain deposits whenever visible
	Headlamp Inspection	Daily	Daily	Check operation daily; apply dielectric grease to connector when replaced
	Tail/ indicator lamp inspection	Daily	Daily	Check operation daily; apply dielectric grease to socket when replaced
●	Air Filter-Main Element	Weekly	Weekly	Inspect –Replace if necessary
●	Transmission Oil Level	20 hrs	Monthly	Inspect monthly; change

18. MAINTENANCE

				annually
	Battery	20 hrs	Monthly	Check/clean Terminals; check fluid level
D	Brake pad wear	10 hrs	Monthly	Inspect periodically
•	Front/Rear axle Gear case Oil	100 hrs	Monthly	Check yearly or every 100 hours
	Engine Cylinder Head and Cylinder Base Fasteners	25 hrs	3 months	Inspect (re-torque required at first service only)
•	General Lubrication	50 hrs	3 months	Lubricate all fittings, pivots, cables, etc.
•	Engine Oil-Level/Change	30 hrs	3 months	Check Level Daily; Break in Service at 1 month. Change oil more often in cold weather use.
•	Dipstick	50 hrs	6 months	Inspect-clean
	Engine breather hose	100 hrs	6 months	Inspect
D	Throttle Cable/ Accelerator pedal	20 hrs	monthly	Inspect –adjust, lubricate, replace if necessary; pre-ride inspection item
	Shift linkage	50 hrs	6 months	Inspect, adjust
D	Drive belt	50 hrs	6 months	Inspect, replace if necessary
D	Steering system	50 hrs	6 months	Check operation and for looseness, worn, damage, binding feeling / Adjust, repair, Replace if necessary. Check toe alignment /Adjust if necessary.

18. MAINTENANCE

D	Toe alignment adjustment	As required	As required	Periodic inspection, adjust when parts are replaced
D	Shaft	50 hrs	6 months	Check for looseness/ damage.
●	Axle	50 hrs	6 months	Inspect bearings, Lube
●	Front Prop Shaft & Shaft Yoke	50 hrs	6 months	Check for looseness/ damage.
●	Rear Prop Shaft, Shaft Yoke & Boots	50 hrs	6 months	Check for/ boots/ looseness/ damage.
●	Front Suspension	50 hrs	6 months	Inspect-lubricate,

				tighten fasteners
●	Rear Suspension	50 hrs	6 months	Inspect, tighten fasteners
	Spark Plug	100 hrs	12 months	Inspect-replace if necessary
D	Ignition Timing	100 hrs	12 months	Inspect and adjust as needed
D	Fuel System	50 hrs	6 months	Check for leaks at tank cap, lines, fuel valve, filter, and carburetor. Replace lines every one year
D	Fuel Filter	100 hrs	12 months	Replace annually
	Radiator	100 hrs	12 months	Inspect/clean external surface
	Spark arrestor	50 hrs	3 months	Clean out-replace if necessary
D	Clutches (drive and driven)	25 hrs	3 months	Inspect, clean

18. MAINTENANCE

	Engine mounts	25 hrs	3 months	Inspect
D	Valve clearance	100 hrs	12 months	Inspect/adjust
D	Brake fluid	200 hrs	24 months	Change every two years
	Idle Speed	As required	As required	Adjust
	Headlight Aim	As required	As required	Adjust if necessary

18. MAINTENANCE

LUBRICATION RECOMMENDATIONS

	Item	Lube Rec	Method	Frequency
•	1. Engine Oil	See note below	Add to proper level on dipstick	Check level daily
	2.Brake Fluid	DOT 3 Only	Maintain level Between fill lines. See "7. CONTROL"	As required, change every two years or 200 hours
	3.Transmission Oil	SAE 80W/90GL5	Add to proper level on dipstick	Change annually or at 100 hours
	4. Front/Rear axle Gear case Oil	SAE 80W/90GL5	Front axle: 250ml Rear axle: 450ml	Change annually or at 100 hours
•	5.Steering system	Grease	Lubricate the pivoting and sliding parts	Every 3 months or 50 hours
•	6.Shift Linkages	Grease	Locate fittings and Grease	Semi-annually
•	7.Front Wheel bearings	Inspect	Inspect and replace bearings if necessary	Semi-annually
•	8.Ball joints	Grease	Inspect, Locate fittings and Grease, or replace it if necessary	Semi-annually
•	9.Prop Shaft & Shaft Yoke, Spline Joint	Grease	Locate fitting and Grease	Semi-annually
•	10.Rear Axle Bearing	Grease	Grease	Every 3s month or 50 hours
•	11.Swing Arm Bearing	Grease	Grease	Monthly or 20 hours

18. MAINTENANCE

•	12. Throttle Cable	Grease M	Grease, inspect and replace it if necessary	Monthly or hours	20
•	13. Accelerator pedal and brake pedal	Grease	Grease, inspect	Monthly or hours	20

Engine Oil Recommendations

For most applications, we recommend using 5 W 30 or 10 W 30 full synthetic oil in the engine. These oils provide superior lubrication of the piston, rings and cylinder under a wide range of operating conditions.

When operating in extreme hot or cold environments you may want to select one of the following options.

For operating conditions where ambient temperatures are consistently above 90 degrees F, upgrade to a 10 w 40 full synthetic oil.

For operating conditions where ambient temperatures are consistently below 0 degrees F, upgrade to a 0 w 20 full synthetic oil.

If you choose to use conventional petroleum based motor oils, follow these recommendations.

For most applications, we recommend using 10 W 30 oil in the engine. These oils provide superior lubrication of the piston, rings and cylinder under a wide range of operating conditions.

When operating in extreme hot or cold environments you may want to select one of the following options.

For operating conditions where ambient temperatures are consistently above 90 degrees F, upgrade to a 10 w 40 oil.

For operating conditions where ambient temperatures are consistently below 0 degrees F, upgrade to a 5 w 20 oil.

Oils specifically designed for use in ATVs, CUVs, and other off road powersport vehicles are specially formulated to provide easy starting and high lubricity in the harshest operating conditions.

18. MAINTENANCE

ENGINE OIL LEVEL INSPECTION

1. Start the engine and let it warm up for a few minutes .
2. Turn off the engine.
3. Wait a few minutes until the oil settles before inspecting the oil level
4. Inspect oil level

Oil level should be between maximum and minimum marks .

If the oil level is below the minimum mark. Add oil up to the proper level.

ENGINE OIL REPLACEMENT

1. Start the engine and let it warm up for several minutes .
2. Turn off the engine and place an oil pan under the engine.

3. Remove :

● Drain plug ①  32Nm(3.2m·kg)

● Compression spring ②

● Oil strainer ③

● O-ring

● Drain the crankcase of its oil.

4. Install:

● O-ring ① NEW

● Compression spring ②

● Oil strainer ③ ● Drain plug ④

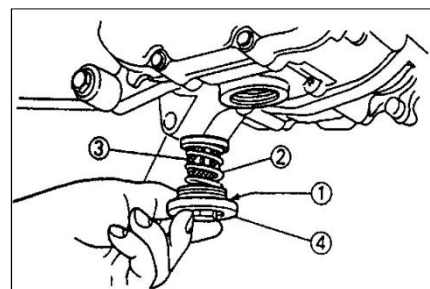
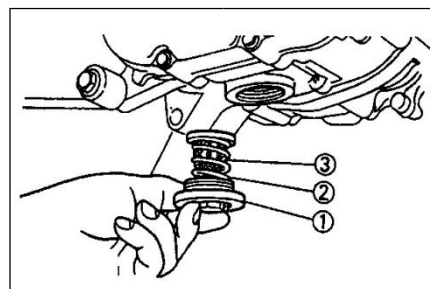

18. MAINTENANCE

NOTE :

Check the drain plug O-ring. If damaged, replace it with a new one.

5. Fill:

- Crankcase

	Oil quantity: 1.4L
---	-----------------------

6. Check:

- Engine oil level

Refer to the "ENGINE OIL LEVEL INSPECTION" section

19. EMISSIONS CONTROL – SYSTEM WARRANTY

MARS CARTS INC.

EMISSION CONTROL SYSTEM WARRANTY

YOUR WARRANTY RIGHTS AND OBLIGATIONS

The emission control system warranty period for this vehicle begins on the date the vehicle is delivered to the first purchaser and each subsequent purchaser, or the date it is first used as a demonstrator, lease, or company vehicle, whichever comes first and continues for 30 months after that date, or 5,000 KM whichever comes first, provided there has been no abuse, neglect or improper maintenance of your vehicle. Where a warrantable condition exists, the Distributor will repair your vehicle at no cost to you, including diagnosis, parts and labor. If an emission-related part on your vehicle is defective, the part will be repaired or replaced by the Distributor. This is your emission control defects warranty.

OWNERS WARRANTY RESPONSIBILITIES

As the vehicle owner, you are responsible for the performance of the required maintenance. You should maintain a record of all maintenance performed on your vehicle and retain all receipts covering maintenance on your vehicle. You may not be denied a warranty claim solely because of your failure to ensure the performance of all scheduled maintenance or lack of maintenance records or receipts. You are responsible for presenting your vehicle to an authorized dealer as soon as a problem exists. The warranty repairs should be completed in a reasonable amount of time, not to exceed 30 days.

As the vehicle owner, you should be aware that you may be denied your warranty coverage if your vehicle or a part has failed due to abuse, neglect, improper maintenance, or unapproved modifications.

WARRANTY COVERAGE

The Distributor warrants that each new vehicle:

- Is designed, built, and equipped so as to conform at the time of ultimate retail purchaser with all applicable regulations of the United States Environmental Protection Agency, and the California Air Resources Board; and
- Is free from defects in material and workmanship which cause such vehicle to fail to conform to applicable regulations of the United States Environmental Protection Agency or the California Air Resources Board for the periods specified above.

19. EMISSIONS CONTROL – SYSTEM WARRANTY

Your emission control system warranty covers components whose failure would increase an engine's emission, including electronic controls, fuel injection system, carburetor, the ignition system, catalytic converter, or any other system utilized in this vehicle to control emission if it is originally equipped. Also included may be hoses, connectors and other emission-related assemblies. Replacing or repairing other components (including parts, labor, and other costs) not covered by this emission control system warranty or the standard warranty is the responsibility of the owner.

Coverage of repairs under this warranty applies only when repairs are completed at an authorized dealer or repair facility. The Distributor will not cover repairs performed outside of an authorized dealer or repair facility, except in an emergency situation. The use of replacement parts not equivalent to the original parts may impair the effectiveness of your vehicles' emission control system. If such a replacement part is used and an authorized dealer determines it is defective or causes a failure of a warranted part, your claim for repair to bring your vehicle into compliance with applicable standards may be denied.

If an emergency exists when a warranted part or a dealer is not reasonably available to the owner, repairs may be performed at any available service establishment, or by the owner, using any replacement part. The Distributor shall reimburse the owner for the expenses, including diagnostic charges, not to exceed the Distributor's suggested retail price for all warranted parts replaced and labor charges based on the Distributor's recommended time allowance for the warranty repair and the geographically appropriate hourly labor rate. The owner may reasonably be required to keep receipts and failed parts order to receive compensation.

The Emission Control System Warranty is in addition to the standard Limited Warranty.

EXCLUSIONS AND LIMITATIONS

This warranty does not cover the following:

- Failures or malfunctions of the emission control systems caused by abuse, alteration, accident, misuse, the use of leased gasoline.
- Replacement of expendable maintenance items unless they are original equipment defective in material or workmanship under normal use, and the first required replacement interval for the item has not been reached. Expendable maintenance items include but not limited to spark plugs, filters, coolant, lubricants, gaskets, hoses, and belts.

19. EMISSIONS CONTROL – SYSTEM WARRANTY

- Replacements of parts and other service and adjustments for required maintenance.
- Any vehicle equipped with an odometer or hour meter where the reading is altered so that actual mileage cannot be readily determined.
- Repairs or replacements as a result of:
 - o Accident
 - o Misuse
 - o Use of replacement parts or accessories not conforming to the original specifications which adversely affect performance.
 - Physical damages, corruptions, or defects caused by fire, explosions or similar causes beyond the control of the Distributors.
 - Failures not caused by a defect in material or workmanship.

Use of the vehicle in any type of competitive racing or related events immediately and completely voids this and all other warranties.

LIMITED LIABILITY

The liability of The Distributor under this Emission Control System Warranty is limited solely to the remedying of defects in material workmanship by an authorized dealer at its place of business during customary business hours. This warranty does not cover in convenience or loss of use of the vehicle or transportation of the vehicle to/from the authorized dealer. The Distributor is not liable to any person for incidental, consequential or special damages of any description, whether arising out of express or implied warranty or any other contract, negligence or other tort or otherwise.

No express emission control system warranty is given by the Distributor except as specifically set forth herein. Any emission control system warranty implied by law, including any warranty of merchant ability or fitness for a particular purpose is limited to the express emission control system warranty terms stated in this warranty. The foregoing statements of warranty are exclusive and in lieu of all other remedies. All express warranties not stated in this warranty are disclaimed. Some states do not allow limitations on how long an implied warranty lasts, so the above limitations may not apply if it is inconsistent with the controlling state law.

No dealer is authorized to modify this Emission Control System Warranty. If you have any questions regarding your warranty rights and responsibilities,

19. EMISSIONS CONTROL – SYSTEM WARRANTY

you should contact MARS CARTS INC. 4112W Spring Creek Pkwy D100,
Plano, TX75024. TEL: 4692698139 .