

INSTRUCTION MANUAL

MODEL: QGZ25-30D

ORIGINAL INSTRUCTION

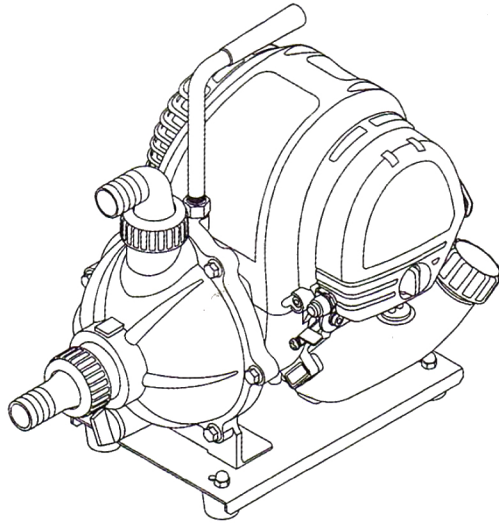

WARNING



Read rules for safe operation and all instructions carefully. Provide this Operation Instruction which must be read and understand for proper and safe operation.

PREFACE

Dear users:

Thank you very much for purchasing our products.

This manual covers operation and maintenance of our products.

Before using, please read this instruction manual carefully to know well about the machine's performance, so as to operate the machine safely and correctly.

Please keep carefully to consulting it later.

Transfer or lend the instruction manual following the machine if transferring or lending this machine. Interpret receiver fully if necessary so as not to damage the machine or be injured because of incorrect operation.

By the way, due to changes of specifications, all details of your machine may not agree with this manual. Please understand accordingly.

Thank you again for having chosen our products.

CONTENTS

1.SAFETY PRECAUTIONS.....	3
2.COMPONENTS.....	6
3.Pre-operation for starting.....	7
1.)CONNECT SUCTION HOSE.....	7
2.)CONNECT DELIVERY HOSE.....	7
3.)CHECK FUEL.....	7
4.)CHECK PRIMING WATER.....	8
4.OPERATING YOUR PUMP.....	8
1.)STARTING.....	8
2.)RUNNING.....	9
3.)STOPPING.....	9
5.MAINTENANCE.....	9
1.)DAILY INSPECTION.....	9
2.)PERIODIC INSPECTION.....	10
3.)INSPECTING THE SPARK PLUG.....	10
4.)CLEANING FUEL FILTER.....	11
5.)CLEANING AIR CLEANER.....	11
6.)ADJUSTING CARBURETOR.....	11
7.)Fuel hose replacement.....	11
8.)CHECKING BOLTS,NUTS AND SCREWS.....	11
6.PREPARATIONS FOR STORAGE.....	12
1.)WATER.....	12
2.)DISCONNECT THE DELIVERY HOSE.....	12
3.)DISCHARGE FUEL.....	12
4.)CLEAN AND STORE.....	12
7.EASY TROUBLESHOOTING.....	13
1.) Cannot start engine.....	13
2.) The engine output is insufficient.....	13
3.) Engine stops while running.....	14
4.) Engine hard to stop.....	14
5.) Trouble and remedy of pump.....	14
8. MAIN SPECIFICATIONS.....	15

1.SAFETY PRECAUTIONS

Please make sure you review each precaution carefully.

Pay special attention to statement preceded by the following words.

 **WARNING** “WARNING” indicates a strong possibility of severe personal injury or loss of life if instructions are not followed.

 **CAUTION** “CAUTION” indicates a possibility of personal injury or equipment damage if instructions are not followed.

WARNING : EXHAUST PRECAUTIONS

- Never inhale exhaust gasses.
They contain carbon monoxide,a colorless,odorless and extremely dangerous gas which can cause unconsciousness or death.
- Never operate the pump indoors or in a poorly ventilated area,such as tunnel,cave,tec.
- Exercise extreme care when operating the pump near people or animals.
- Keep the exhaust pipe free of foreign objects.

WARNING : REFUELING PRECAUTIONS

- Gasoline is extremely flammable and its vapors can explode if ignited.
- Do not refuel indoors or in a poorly ventilated area.
- Be sure to stop the pump prior to refueling.
- Do not remove fuel tank cap nor fill fuel tank while engine is hot or running.
Allow engine to cool at least 2 minutes before refueling.
- Do not overfill the fuel tank.
- If fuel is spilt,wipe it away carefully and wait until the fuel has dried before starting the engine.
- After refueling,make sure that the fuel cap is secured to prevent spillage.

WARNING : FIRE PREVENTION

- Do not operate the pump while smoking or near an open flame.
- Do not use around dry brush,twigs,cloth rags,or other flammable materials.
- Keep cooling air intake(recoil starter area) and muffler side of the engine at least 1 meter(3 feet) away from building,obstructions and other burnable objects.
- Keep the pump away from flammables and other hazardous materials(trash,rags,lubricants,explosives).

⚠ WARNING : OTHER SAFETY PRECAUTIONS

- Be careful of hot parts.

The muffler and other engine parts become very hot while the pump is running or just after it has stopped. Operate the pump in a safe area and keep children away from the running pump.

- Do not use diaphragm pump for the mixture of water and oil.
- Do not touch the spark plug and ignition cable when starting and operating the engine.
- Operate the pump on a stable, level surface.

If the engine is tilted, fuel spillage may result.

NOTE

Operating the pump at a steep incline may cause seizure due to improper lubrication even with a maximum oil level.













- Drain the fuel when transporting the pump.
- Keep the unit dry (do not operate it in rainy conditions).

⚠ CAUTION : PRE-OPERATION CHECKS

- Carefully check fuel hoses and joints for looseness and fuel leakage. Leaked fuel creates a potentially dangerous situation.
- Check bolts and nuts for looseness. A loose bolt or nut may cause serious engine trouble.
- Check the engine oil and refill if necessary.
- Check the fuel level and refill if necessary. Take care not to overfill the tank.
- Keep cylinder fins and recoil starter free of dirt, grass and other debris.
- Wear snug fitting working clothes when operating the engine.

Loose aprons, towels, belt, etc., may be caught in the engine or drive train, causing a dangerous situation.

SYMBOLS

	<p>Read the owner's manual.</p>		
	<p>Stay clear of the host surface.</p>		
	<p>Exhaust gas is poisonous. Do not operate in an unventilated area.</p>		
	<p>Stop the engine before refueling.</p>		
	<p>Fire, open flame and smoking prohibited.</p>		
	<p>On (Run)</p>		<p>Plus; Positive polarity</p>
	<p>Off (Stop)</p>		<p>Battery</p>
	<p>Engine oil</p>		<p>Engine start (Electric start)</p>
	<p>Add oil</p>		

2.COMPONENTS

NOTE Please refer to the illustrations indicated in the sentence.

Fig.1

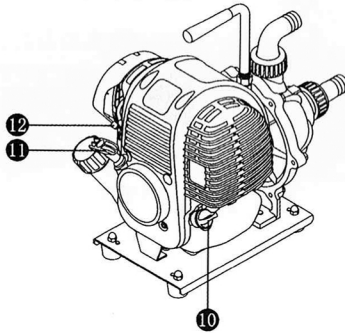
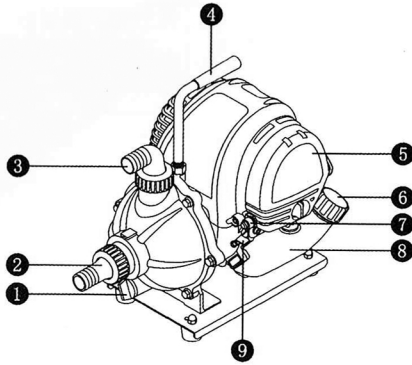

- | | | |
|---------------|-------------------------|-----------------------|
| ① Plug(drain) | ② Suction | ③ Delivery |
| ④ Handle | ⑤ Air cleaner | ⑥ Fuel tank cap |
| ⑦ Stop Switch | ⑧ Fuel tank | ⑨ Speed control lever |
| ⑩ OIL SCALE | ⑪ Recoil starter handle | ⑫ Choke lever |

3. PRE-OPERATION FOR STARTING

1.) CONNECT SUCTION HOSE

- Use a reinforced-wall or wire braided hose to prevent suction collapse.
- Since the pump self-priming time is directly proportional to hose length, a short hose is recommended.

CAUTION

Always use a strainer with the suction hose. Gravel or debris sucked into the pump will cause serious damage to the impeller and the pump casing.

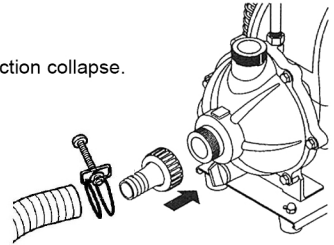

Fig.2

Fig.3

2.) CHECK PRIMING WATER

- It is recommended that the water chamber of pump casing should be primed with full of water before operating.

WARNING

Never attempt to operate the pump without priming water or the pump will overheat. Extended dry operation will destroy the mechanical seal.

If the unit has been operated dry, stop the engine immediately and allow the pump to cool before adding priming water.

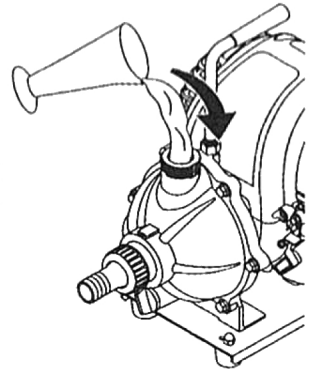

3.) CHECK FUEL

- Stop the engine and open the cap.
- If level is low, fill to the shoulder of the fuel filler.
- Use automotive gasoline (unleaded or lowleaded is preferred to minimize combustion chamber deposits). Never use an oil/gasoline mixture or dirty gasoline. Avoid getting dirt, dust or water in the fuel tank.

WARNING

Do not refuel while smoking, near an open flame or other such potential fire hazards. Otherwise fire accident may occur.

- Wipe off any spilled fuel before starting the engine.

4.)CONNECT DELIVERY HOSE

- When using a fabric hose,always use a hose band to prevent the hose from disconnecting under high pressure.

Fig.5

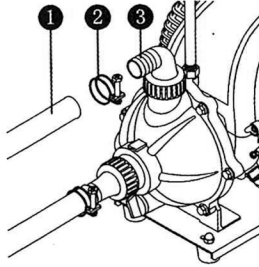

4.OPERATING YOUR PUMP

1.)STARTING

- Turn the STOP SWITCH to the "I"(ON). (Fig.6)
- Push the primer button 5 to 7 times to feed the fuel to the carburetor.(Fig.7)
- Set the speed control lever 1/3 to 1/2 of the way towards the high speed position.(Fig.8)
- Close the choke lever. (Fig.9)

Fig.6

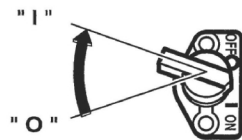

NOTE If the engine is cold or the ambient temperature is low,close the choke lever fully.
If the engine is warm or the ambient temperature is high,open the choke lever half-way,or keep it fully open.

Fig.7

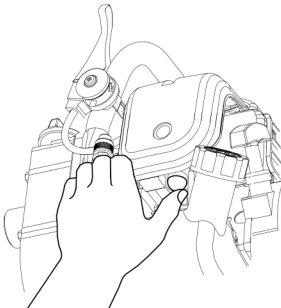

Fig.8

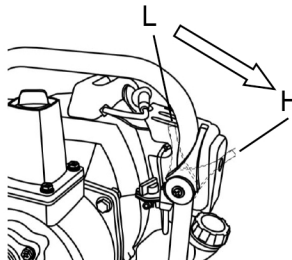
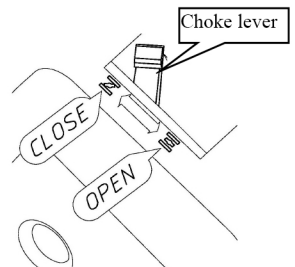

Fig.9



- Pull the starter handle slowly until resistance is felt. (Fig.10)

This is the "compression" point. Return the handle to its original position and pull swiftly.

Do not pull out the rope all the way.

After starting the engine, allow the starter handle to return to its original position while still holding the handle.

- After starting the engine, gradually open choke by turning the choke level and finally keep it fully opened. (Fig.9)

Do not fully open the choke lever immediately when the

engine is cold or the ambient temperature is low, because the engine may stop.

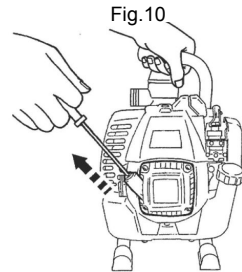

2.) RUNNING

- After the engine starts, set the speed control lever at the low speed position ("L", Fig.8) and warm it up without load for a few minutes.
- Gradually move the speed control lever toward the high speed position ("H", Fig.8) and set it at the required engine speed.

Whenever high speed operation is not required, slow the engine down (idle) by moving the speed control lever to save fuel and extend engine life.

3.) STOPPING

- Set the speed control lever at the low ("L", Fig.8) speed position and allow the engine to run at low speed for 2 or 3 minutes before stopping.
- Set the stop switch to the position "OFF" ("O", Fig.6).

NOTE Do not stop the engine suddenly when it is running at high speed.

- Pull the starter handle slowly and return the handle to its original position when resistance is felt. This operation is necessary to prevent outside moist air from intruding into the combustion chamber.

5. MAINTENANCE

1.) DAILY INSPECTION

- Before running the engine, check the following service items.
 - a. Loose or broken bolts and nuts.
 - b. Clean air cleaner element.
 - c. Leakage of gasoline and engine oil.
 - d. Enough gasoline.
 - e. Safe surroundings.
 - f. Check the priming water.
 - g. Excessive vibration, noise.

2.)PERIODIC INSPECTION

- Periodic maintenance is vital to the safe and efficient operation of your product.
- Check the table below for periodic maintenance intervals.The below chart is based on the normal product operation schedule.

 CAUTION
<p>Replace rubber pipes for fuel passage every two years. If fuel leakage is found,replace the pipe immediately.</p>

Periodic Maintenance Schedule table

Maintenance items	Every 8 hours (Daily)	Every 50 hours (Weekly)	Every 200 hours (Monthly)	Every 500 hours	Every 1000 hours
Clean pump set and check bolts and nuts	● (Daily)				
Engine oil	● (Change)				
Clean spark plug		●			
Clean air cleaner		●			
Remove the pump casing and clean			●		
Clean fuel strainer			●		
Clean and adjust spark plug and electrodes			●		
Clean and adjust carburetor				●	
Clean fuel tank				●	
Overhaul engine if necessary					●

3.)INSPECTING THE SPARK PLUG

- Clean off carbon deposits on the spark plug electrode using a plug cleaner or wire brush.
- Check electrode gap.The gap should be 0.6mm to 0.7mm.(Fig.11)
Adjust the gap,if necessary,by carefully bending the side electrode.

Fig.11

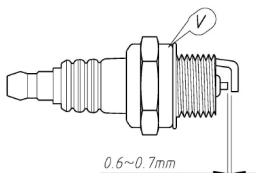
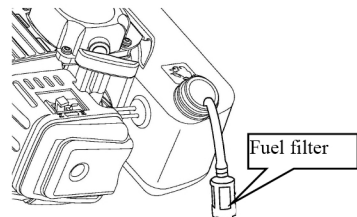

Fig.12



4.)CLEANING FUEL FILTER

 **WARNING** Flame Prohibited

- Remove the hose clamp and pull out the fuel filter from fuel pipe. (Fig.12)
- Wash the fuel filter with kerosene.
- After washing,reassemble it.
- If the fuel filter is heavy dirty,replace it with new one.

5.)CLEANING AIR CLEANER

 **WARNING** Flame Prohibited

- Dirty air cleaner element will cause starting difficulty,power loss,engine malfunctions, and shorten engine life extremely.Keep the air cleaner element clean.
- Remove the air cleaner cover and wash it in kerosene or diesel fuel.
- Then saturate it in a mixture of 3 parts kerosene or diesel fuel and 1 part engine oil.
- Squeeze the element to remove the mixture and install it in the air cleaner.
- Clean and replace air cleaner elements more often when operating in dusty environments.

6.)ADJUSTING CARBURETOR

Adjusting idling rpm.(Normal idling rpm:3000±200rpm)

When adjust screw is turned right,engine rpm increases,and when it is turned left,rpm decreases.(Refer to illustration).

 **CAUTION** The carburetor greatly affects the performance of the engine.

Since it has been adjusted carefully at our factory before shipment,avoid adjusting unless absolutely necessary.If adjustments are needed,contact your nearest dealer.

7.)FUEL HOSE REPLACEMENT

Replace the fuel pipe every 1 year.If fuel leakage is found on the fuel pipe,replace it immediately.

 **WARNING** Take extreme caution when replacing fuel hose;gasoline is extremely flammable.

8.)CHECKING BOLTS,NUTS AND SCREWS

- Retighten loose bolts and nuts.
- Check for fuel and oil leaks.
- Replace damaged parts with new ones.

6. PREPARATIONS FOR STORAGE

1.) WATER

- Drain all water from the drain plug. (Fig. 13)

⚠ CAUTION When retightening drain plug, be sure to clean the drain plug and the thread of casing. Otherwise, the thread may be damaged.

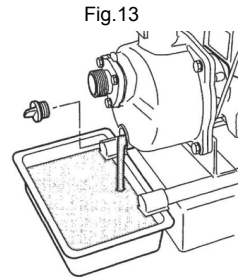

2.) DISCONNECT THE DELIVERY HOSE

- Tilt the pump and drain all water from delivery hole. Severe damage to pump may result if water freezes in the pumping chamber.

3.) DISCHARGE FUEL

⚠ WARNING Flame Prohibited

- In case the engine is not going to be used for more than 1 month, discharge fuel thoroughly from fuel tank and carburetor in order to prevent from hard starting and/or poor engine operation due to deteriorated fuel when you use the engine next time.
- ① Pour out the fuel in the tank from its filler neck.
 - ② Push the primer pump of the carburetor until the fuel in it is thoroughly discharged.

4.) CLEAN AND STORE

Slowly pull the recoil starter handle until resistance is felt and leave it in that position.

Clean the pump thoroughly with an oiled cloth, put the cover on, and store the pump indoors in a well ventilated, low humidity area.

7.EASY TROUBLESHOOTING

1.) CANNOT START ENGINE

Trouble		Causes	Remedies
The sparking plug miss fire	Sparking plug	Firing device wetted	Dry it out
		The carbon lay down on the sparking plug	Clean the carbon
		The spark gap is too big or too small	Adjust gap at 0.6~0.7mm
		The poles of sparking plug burned	Replace it
		The insulation damaged	Replace it
	Magneto	The junction of wire drop off or broken	Tighten or replace it
		The insulation of coil bad	Change
The gap between stator and rotor is too big		Adjust gap at 0.4mm	
The sparking plug works normal	Compression ratio is fine and fuelling normally	The fuel suck in excess	Reduce the fuel
		The quality of fuel is bad and mix with water and dirty	Change the fuel
	Fueling well but compression ratio bad	Cylinder and piston ring wore or tore	Replace them
	Carburetor no fueling	No fuel in the tank	Feed the fuel
		Fuel cock is not open	Open it
		The air hole of the tank clogged	Clean

2.) THE ENGINE OUTPUT IS INSUFFICIENT

Trouble	Causes	Remedies
The compression ratio is fine and the fire has not gone out	The union of fuel pipe suck in the air	Tighten it
	The connection of carburetor suck in air	Change seal and tighten it
	The fuel mix with water	Change the fuel
	The filter plate clogged	Clean
	The carbon clogs muffler, cylinder	Clean
Engine overheats	Mixed gas thin	Adjust the carburetor
	Cylinder covered with carbon	Clean
Engine noisy or knocking	Fuel bad	Replace
	Firing chamber covered with carbon	Clean
	The running parts wore and tore	Check and replace

3.) ENGINE STOPS WHILE RUNNING

Trouble	Cause	Remedies
Engine stops suddenly	The piston bitten	Change the piston or remedy it
	The sparking plug laid down the carbon and short circuited	Clean out the carbon
	Magneto is bad	Check and remedy
The engine stops slowly	Fuel is short	Feed the tank
	Carburetor clogged	Clean
	Water in fuel	Refill with fresh fuel

4.) ENGINE HARD TO STOP

Trouble	Cause	Remedies
Engine	Cylinder and piston overheat conduce to self ignition	Clean carbon
Correlative circuit	Plug pole overheats	Clean the plug and check the gap
	Stop button is bad	Check and remedy

5.) TROUBLE AND REMEDY OF PUMP

Trouble	Cause	Remedy
Can not self-suck	No water or water shortage in pump	Feed water
	Sealing of junction damaged or junction loosened make the suction hose suck in air	Change or tighten
	Suction hose broken up make the air is sucked in	Change the pipe
	The valve connected on the discharge side is closed or doubled	Check and adjust
	The gap of impeller and volute shell is incorrect	Adjust
	The pump clogged by foreign body	Clean
Water outlet is insufficient and pressure is too low	The strainer of sucking pipe clogged	Clean
	The suction hose doubled and clogged	Clean
	The pump clogged by foreign body	Clean
	Impeller and volute shell wore out	Change
	The position of discharge port is too high	Change the installing of pump
Can not pull the starter	Impeller and volute shell rusting	Clean
	The pump clogged	Clean
Leaking water	Mechanical seal wore out	Change
	O-sealing ring of pump shaft damaged	Change

8. MAIN SPECIFICATIONS

Name		Self-suction type centrifugal pump		
Model		QGZ2-30D		
Dimensions(L×W×H)		380X250X380		
Weight		6.5kg		
P U M P	Suction port diameter	25mm		
	Discharge port diameter	25mm		
	Discharge(Max.)	8m ³ /h		
	Total water head (Max.)	30m		
	Suction water head (Max.)	8m		
	Self-suction time(3m)	≤80s		
	Shaft sealant	Mechanical seal(ceramic carbon)		
E N G I N E	Type	Air-cooled four cycle engine		
	Model	139F	GX35	140FA
	Power(Max.)	0.7kW	0.9kW	1.0kW
	Total displacement	31CC	35.8CC	37.7CC
	Way of ignixion	Electronic ignition (CDI)		
	Ignition system	Transistor magneto		
	Fuel applicable	Gasoline		
	Tank capacity	0.7L	0.65L	0.65L
	Lubricant	4-stroke oil (SAE 10W-30)		

NOTE Specifications are subject to change without notice.