



Certified to NSF/ANSI 61 & 372

# 'IPW' Pumps "Potable Water"

Models: IPW2WL, IPW2BWL

*\*Certified to NSF/ANSI 61 & 372*

OPERATION AND  
SERVICE GUIDE  
PO-1725IPW  
AUGUST 2022

## OPERATOR'S MANUAL & PARTS LIST for Self-Priming Centrifugal Pumps

Self-Priming • Corrosion Resistant • Lightweight • High Volume • High Lift

Stainless Steel, Potable Water Elastomers and Plastics

PLEASE READ SECTION I, II, AND III BEFORE OPERATING PUMP

I. Safety Precautions.....	2
II. Preparing the Pump for Operation .....	2
III. Pump Operating Instructions .....	2
IV. Pump Troubleshooting & Repair .....	3
V. Pump Parts List.....	4
VI. Pump Assembly Instructions.....	5

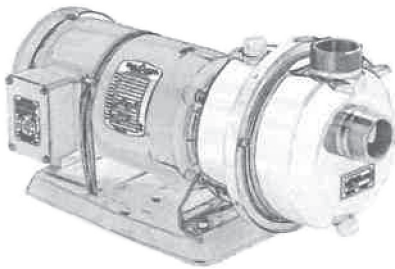

Electric Drive Close Coupled

### AVAILABLE MODELS

#### **NPT Thread**

*IPW2WL*

*IPW2WL E5HCP*

*IPW2WL E6HCP*

*IPW2WL E6VCP*

*IPW2WL CSS*

*IPW2WL HYC*

*IPW2WL C3.0C*

*IPW2WL D3.0C*

*IPW2WL CX208*

*IPW2WL E5.5*

*IPW2WL KD15225*

*IPW2WL L48*

#### **BSP Thread**

*IPW2BWL*

*IPW2BWL E5HCP*

*IPW2BWL E6VCP*

*IPW2BWL CSS*

*IPW2BWL HYC*

*IPW2BWL C3.0C*

*IPW2BWL D3.0C*

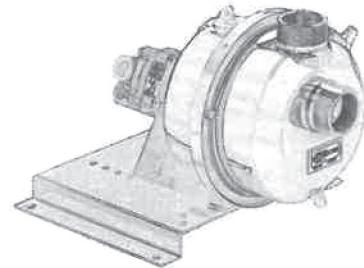

Hydraulic Drive Close Coupled

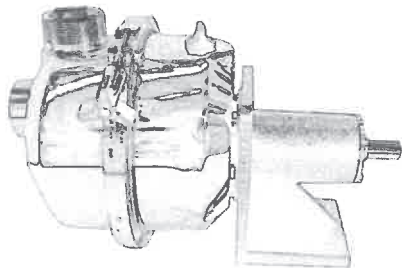

Cast Iron Pedestal Mounted

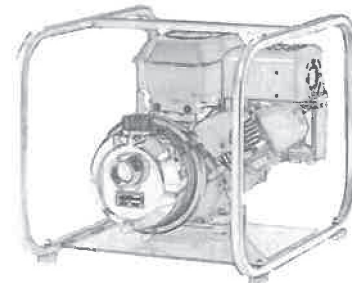

Engine Drive Close Coupled  
(Shown with Optional Roll Cage)



## I. SAFETY PRECAUTIONS

1. Before starting the pump, follow all of the instructions in this manual and any supplemental instructions supplied with the pump.
2. Any person operating this pump and its power unit should be fully aware of its safe operation before they start using it.
3. Never operate an engine driven unit in an explosive atmosphere, near combustible materials, or where insufficient ventilation exists unless specific provisions have been made regarding the power unit so as to prevent possible injury and damage. Be certain any other power unit is safe for the area in which it is to be operated.
4. Always be sure that the pump is on secure footing so that it cannot slide, shift, or tip over. If the pump is sitting beside a pit, secure it so that it does not fall in. Engine units have slots and holes for fastening to a secure base. Baseplate, skid rail, and roll cage kits are available from your pump dealer.
5. Never operate the unit with any guards removed.
6. With engine driven pumps:
  - a. In refueling engine, observe all safety precautions for the handling of fuel.
  - b. Never refuel the engine while running, and care should be exercised so that no fuel is spilled on a hot engine. Always allow engine to cool at least two minutes before refueling.
9. Before working on this pump make sure that the power unit cannot inadvertently be started.
10. Be sure that the power unit, pump, wiring and piping installations are suitable for the liquid being pumped, and comply with all applicable codes and regulations.
11. Do not use torches or apply fire or flames to this pump for any reason.
12. Do not overtighten the drain or filler plugs. Hand tighten only. Excessive force may damage the threads or the pump body. Do not use metal plugs.
13. Use at least one foot of flexible hose to make plumbing connections to the pump body. Rigid piping may put stresses on the pump, causing damage. **IF RIGID PIPING MUST BE USED, PROPERLY SUPPORT IT SO AS TO ELIMINATE STRESSES ON THE PUMP.**
14. Do not tighten inlet and discharge fittings more than one turn beyond hand tight. Excessive force will damage the pump or fittings.
15. Long suction and discharge hoses or pipes must be supported so that the weight of the hoses or pipes filled with liquid does not damage the pump or tip it over.
16. Use replacement parts supplied by the manufacturer only.
17. Do not run the pump dry. Always fill the pump body with the liquid to be pumped before starting the pump. It is not necessary to drain the pump body after use, *unless* there is danger of freezing.
18. Consult factory for specific recommendations concerning temperature.
19. Do not restrict flow through the pump such as with a closed discharge valve or "starved" suction line. Harmful heat build up will result. If it is necessary to restrict flow through the pump for longer than 5 minutes, either the pump must be stopped or a discharge bypass line installed to keep liquid temperatures below the maximum recommended operating temperatures.
20. This pump must not be subjected to more than 65 pounds per square inch internal pressure. The pump itself, normally, cannot develop more than 32 pounds per square inch pressure. The pump must *not* be used under any of the following unusual conditions which can result in excessive pressures being developed.
  - A. Pump shaft speed over 3600 RPM.
  - B. Quick closing valves in discharge line or any other device which may introduce hydraulic shock into the system.
  - C. Possible sudden obstruction of discharge line such as vehicle driving over hose.
  - D. High positive suction pressures (such as with a flooded suction) which would increase the total system pressure to 65 PSI or above.

## II. PREPARING THE PUMP FOR OPERATION

### PUMP PREPARATION

1. Inspect unit for shipping damage immediately upon receipt and before signing for merchandise. If any visible damage exists, note damage on shipping bill of lading or receiving document(s) *before* signing. Also notify your dealer or distributor immediately of any damage to the shipment.
2. Read these instructions and the power unit instructions until you are sure you can operate it safely and correctly.
3. Consult potable water guidelines and/or cleaning and sanitizing methods.
4. **Sanitize before use!**

### POTABLE WATER EPDM

*This pump is equipped with EPDM shaft seal and EPDM static seals. These elastomers ("rubber parts") are suitable for use with potable water.*

### POWER UNIT PREPARATION - GASOLINE ENGINE DRIVEN PUMPS:

1. For complete operating and maintenance information consult the engine manufacturer's instructions included with the pump.

2. Before starting, fill crankcase with oil specified by the engine manufacturer. Use a high quality detergent oil classified for service SE, SF or SG. Do not add anything to the recommended oil.
3. Before starting, fill fuel tank with clean, fresh, unleaded grade automotive gasoline. *Do not mix oil with gasoline.*

**CAUTION:** The engine governor is set at the factory. Do not tamper with any part which may increase the governed engine speed.

### POWER UNIT PREPARATION - ELECTRIC MOTORS:

1. Before starting, fill fuel tank with clean, fresh, unleaded grade auto-phase or three phase, and is of the proper voltage according to the motor specification plate.
2. *Be sure of the proper motor rotation.* Pump impeller should rotate counterclockwise, looking from the suction inlet side. For single phase motors consult the motor manufacturer's instructions for wiring for counterclockwise rotation. Three phase motor rotation may be reversed by interchanging any two of the three power leads.
3. Make certain that wiring for your electric motor complies with all existing local codes.

## III. PUMP OPERATING INSTRUCTIONS

1. Fill the pump body with liquid before starting. Do not run the pump dry; damage to the seal may result. There are no points on the pump which need lubrication. The shaft seal is self lubricating, and designed to handle clean liquids.
2. Make certain that all hose and pipe connections are airtight. **IMPORTANT:** An air leak in the suction line may prevent priming, and will reduce the capacity of the pump.
3. Always place the pump as close to the liquid to be pumped as possible. Keep all lines as short and straight as possible. Avoid sharp bends in hoses. Keep the pump on a level foundation. See Figure 1.
4. If flexible hose must be laid across a roadway, protect it with planking. Instantaneous shut-off pressure applied when a vehicle runs across an unprotected hose will cause "hydraulic shock". This shock can damage the pump and/or damage the hose.
5. Drain the pump body whenever there is a danger of freezing.
6. Always use rubber feet under portable pump when operating on a hard surface. This will prevent damage to the pump and power unit. Order Kit P-58-0114.

## IV. PUMP TROUBLESHOOTING AND REPAIR

### DIAGNOSIS

- Does not prime or does not pump

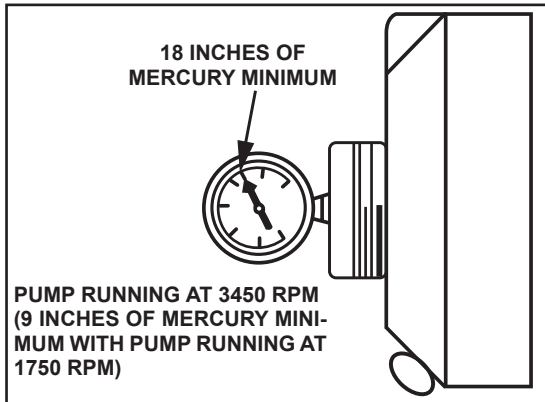

FIGURE 4.

- Pump has insufficient flow

### TREATMENT

- Fill pump with clean liquid and try priming again.
  - Shut off power source to pump. Shut off valves to and from pump. While observing all safety precautions for the liquid being pumped, disconnect suction and discharge lines and drain the pump completely. Fill the pump with water. Install a vacuum gauge in the suction port (see figure 4). Turn on power source. Vacuum should exceed 18" of mercury when pump shaft is rotating at 3450 RPM and should equal or exceed 9" of mercury with pump shaft rotating at 1750RPM. If vacuum is below these values, check the following:
    - Leak at suction fitting
    - Pump rotation. Impeller should rotate counterclockwise when viewing through suction end.
    - Pump speed. (Maximum vacuum performance drops off rapidly with decreasing RPM.)
    - Sealing of check valve gasket between body and volute.
    - Check for worn impeller and/or volute. If necessary, replace these parts. (See items 14 and 15 of section V).
    - Worn shaft seal.
  - If pump suction test OK, attach suction line and check suction at end of suction line. Failure to get suction here indicates leaking connections, leaking hoses, pipes or obstructions in the lines. Liners of suction hose will occasionally collapse inside the hose.
- 
- Check same items as in 1, 2 and 3 above.
  - Replace any worn or broken components; check clearance between impeller vanes and volute face (See section V #14).

## LIMITED 1 YEAR WARRANTY

Pacer Pumps warrants its products to be free from defects of material and workmanship for a period of one year (12 months) of service, if the one year of service falls within 24 months from date of manufacture. The company warrants that its products, at the time of shipment, will be free of defects of material and workmanship for normal use and service. This warranty will not apply or be extended to products subjected to misuse, neglect, accident, or improper installation, or to maintenance of products which have been altered or repaired by anyone except Pacer Pumps or its authorized representatives. The Buyer, or any person receiving such a product during the duration of the warranty, shall contact his Pacer Pump's dealer as soon as any defect occurs. Contact Pacer Pumps for the name and address of your nearest dealer.

Pacer Pumps' sole obligation under the foregoing warranty shall be limited to (at its option) repair and replacement (and reship to the Buyer with transportation charges collect to any place in the U.S.) of defective goods provided that if the company is unable to correct a defective component part or product, the Buyer shall be entitled to elect a credit at the original Buyer's purchase price. To return a DEFECTIVE PUMP, to return any parts for credit, or to obtain service information, contact the Service Department. After receiving permission to return merchandise, the Buyer is authorized to return the product to Pacer Pumps, freight prepaid. If the company determines that the warranty has not been breached, product will be repaired or replaced free of charge.

Certain components, such as mechanical seals, ceramic liners, impellers, impeller magnet assemblies, pistons, hose, diaphragms, etc. may be subject to wear, and therefore wear should not be misconstrued as to the existence of a defect and as such would not be included in a warranty claim, nor should it be implied that items such as this will last a year without occasional, or even frequent replacement depending upon the severity of the application.

The company will not be responsible for any damage or losses, direct or indirect, arising from any cause whatsoever, nor for damage to equipment caused by outside influences including improper installation or modification, improper voltage supply, lightning, corrosive liquids, abrasive liquids, or careless handling; nor for labor, transportation or other damages incurred in the replacement or repair of defective parts. In these cases, repair will be subject to reconditioning charges in effect at the time.

Purchased merchandise, either as a complete product for resale, or components used in conjunction with Pacer Pumps manufactured products, carries the warranty of the respective manufacturer of such product or components. **Pacer Pumps' only warranties the "wet-end" of the pump. Drivers (e.g. electric motor, gasoline, engine etc.), are to be looked at by their appropriate manufacturers' service or repair center.**

This warranty supersedes any warranty previously in effect.

Note: All specifications, as shown, are subject to change without previous notices.



41 Industrial Circle                      717-925-8240  
 Lancaster, PA 17601-5927 U.S.A.      800-233-3861  
 Email: sales@pacerpumps.com      FAX: 717-925-8242  
 Web: www.pacerpumps.com

*servicing  
 industry  
 worldwide*



## V. PUMP PARTS LIST

2" Self-Priming Centrifugal Pump for Potable Water

Model: IPW2WL

Price Code: P-57-12W4      Driver: Pump End Only

NO.	DESCRIPTION	QTY	PART NO.	NO.	DESCRIPTION	QTY	PART NO.
1	Spacer      PET	4	58-1244-30	15	Shim      SS .006"	As Req.	58-0778-11
2	Body, rear      SS 316	1	58-1308-10		.015"		58-0778-12
3	Support O-Ring      EPDM	1	58-1361-72N		.030"		58-0778-13
4	Support      PP	1	58-1301-40N	16	Impeller      PP	1	58-0683-40N
5	2pc. Shaft Seal      FKM, SS 316, carbon/ceramic .75"	1	58-0714-14N	17	Impeller Screw      SS 316 5/16"-24x.75"	1	58-0716-10
6	Support Screw      EPDM O-Ring	5	58-0717-72N	18	Volute, front      PP Flat	1	58-1303-40N
7	Support Screw      SS, 5/16-24x1 1/4"	4	58-0715-10	19	Check Valve      EPDM	1	58-1872-72N
8	Support Screw      PP Plug O-Ring	4	58-1245-72N	20	Body O-Ring      EPDM	1	58-1312-72N
9	Support Screw      PP Plug	4	58-1233-40N	21	Body, front      SS 316	1	58-2012-10
10	Rear Volute      EPDM O-Ring	1	58-1203-72N	22	Drain Plug      EPDM O-Ring	1	58-1009-72N
11	Volute, rear      PP	1	58-1302-40N	23	Drain Plug      PP	1	58-0723-40N
12	Volute Screw      SS #10x3/4"	7	58-1348-10	24	V-Band Knob	1	58-1282-90
13	O-Ring Segment      EPDM	1	58-1246-72N	25	V-Band Clamp      SS	1	58-1280-01
14	Shaft Key      SS, 3/16" SQ. x 15/16" Long	1	58-0718-10	26	Filler Plug      EPDM O-Ring	1	58-0765-72N
				27	Filler Plug      PP	1	58-0722-40N

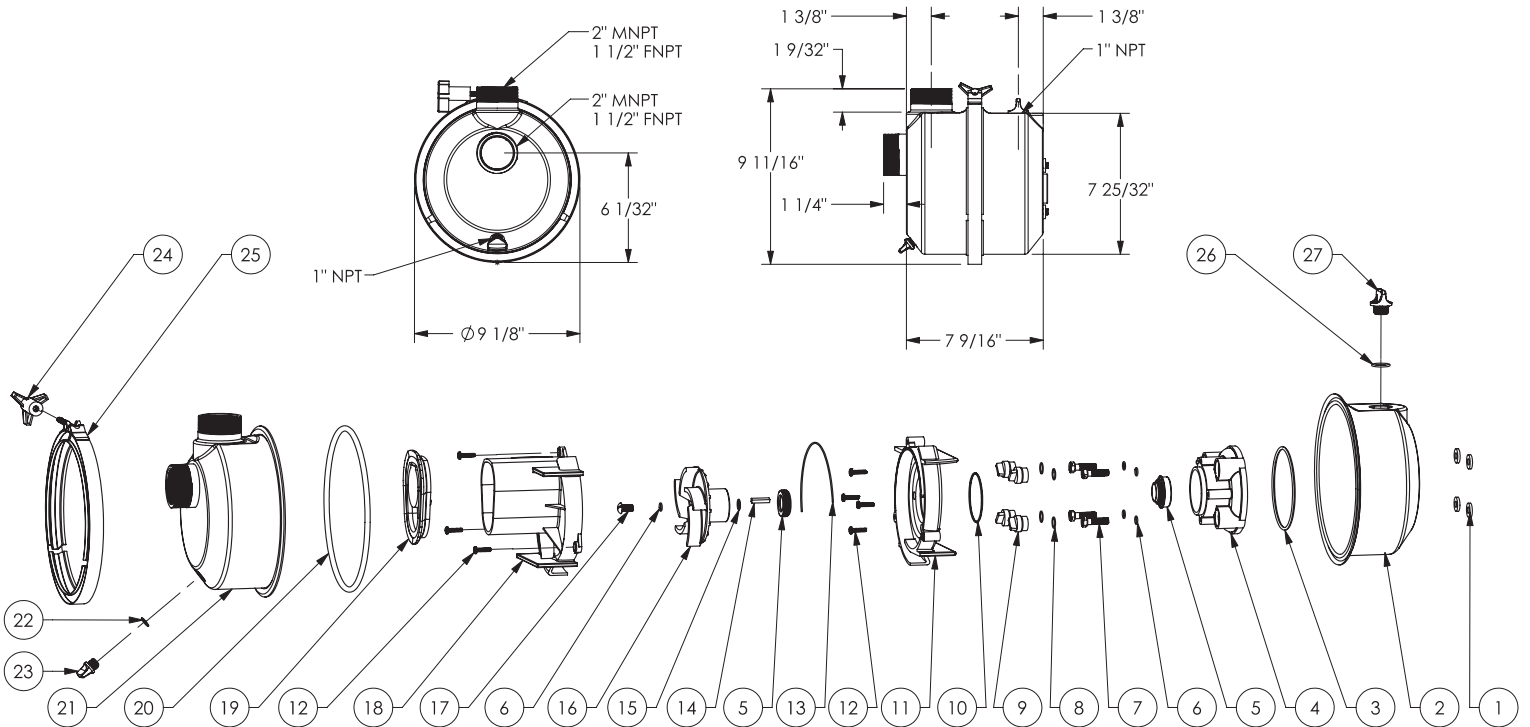

## VI. ASSEMBLY INSTRUCTIONS

*Models: IPW2WL, IPW2BWL*

1. **ONCE PUMP IS ASSEMBLED, SANITIZE PUMP FULLY BEFORE USE. USE A FOOD-GRADE LUBRICANT (e.g. CRISCO, VEGETABLE OIL, ETC.) TO LUBRICATE RUBBER COMPONENTS (O-RINGS/ELASTOMERS).**
2. Place engine with shaft in vertical position.
3. Place spacers (Ref. #1) and rear body (Ref. #4) with fill plug hole facing up.
4. Lubricate O-Ring (Ref. #5). Install on rear of support (Ref. #6). Place on rear body with weep hole in own position.
5. Install support screw with O-Ring (Ref. #7 & 14) and tighten.
6. Lubricate and install plug O-Ring (Ref. #8), then install plug (Ref. #9).
7. Lubricate and install volute O-Ring (Ref. #28).
8. Place rear volute (Ref. #11). Note locating pin position install (4) screws (Ref. #16) and tighten.
9. Lubricate impeller seal face, install impeller on shaft (Ref. #13), apply pressure to impeller and rotate. If impeller touches volute, install shims (Ref. #21) until clearance is obtained. Remove impeller, insert key (Ref. #10) into keyway of impeller (a dab of vegetable shortening on the key will help hold it in place when installing impeller on shaft), re-install impeller, install impeller screw (Ref. #15) with O-Ring and tighten.
10. Press segment (Ref. #12) into groove in volute.
11. Place front volute (Ref. #29) onto rear volute, install (3) screws (Ref. #16) and tighten.
12. Lubricate and place body O-Ring (Ref. #23) on outer flange of rear body. Place check valve (Ref. #27) on to volute, press firmly to make certain it is seated.
13. Place front body (Ref. #19) onto pump (discharge port pointing toward top of pump). Install body clamp (Ref. #20) around body flange and tighten.
14. Install fill plug with O-Ring (Ref. #2 & #3) and drain plug with O-Ring (Ref. #17 & #18) and tighten.
15. With pump assembled, turn shaft to check impeller clearance.