

USER MANUAL

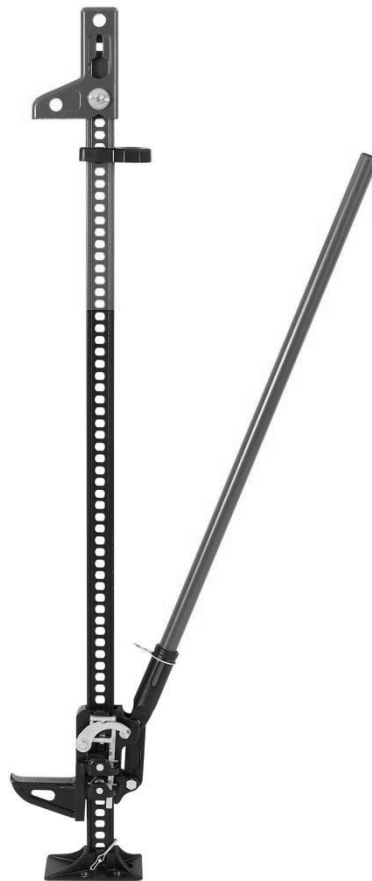

6039127

60 IN. FARM JACK



SPECIFICATIONS

Weight Capacity	5000 lb. (4.5 - 41 in) 3300 lb. (41 - 53 in)
Height	60 in
Minimum Lift Height	4.5 in
Maximum Lift Height	53 in

WARNING INFORMATION



This is the safety alert symbol. It is used to alert you to potential personal injury hazards. Obey all safety messages that follow this symbol to avoid possible injury or death.

⚠️ WARNING

WARNING: Indicates a hazardous situation which if not avoided, could result in death or serious injury.



IMPORTANT: READ THESE INSTRUCTIONS BEFORE USE.

Before using this jack, read this manual completely and thoroughly, understand its operating procedures, safety warnings and maintenance requirements.

It is the responsibility of the owner to make sure that all personnel read this manual prior to using this jack, it is also the responsibility of the jack owner to keep this manual intact and in a convenient location for all to see and read.

⚠️ WARNING

Failure to heed these markings may result in personal injury and/or property damage:

- ✓ Study, understand, and follow all instructions before operating this device.
- ✓ Do not exceed rated capacity.
- ✓ Use only on hard, flat, level surfaces.
- ✓ Lift only on areas of the vehicle as specified by the vehicle manufacturer.
- ✓ Immediately after lifting, support the vehicle with appropriate means.
- ✓ Wear ANSI-approved safety goggles and heavy-duty work gloves during use.
- ✓ Keep clear of load while lifting and lowering.
- ✓ Keep head and body clear of the jack handle path during use.
- ✓ When the jack is under load, the handle must be in the upright position and clipped to the main rail.
- ✓ When changing jack from lifting to lowering, the handle must be in the upright position and clipped to the main rail.
- ✓ When lowering the load, keep head, body, and hands clear of the handle path and hold the jack handle firmly with both hands.
- ✓ When lowering the load, the jack handle will have an upward force that must be resisted by the user's hands in a controlled manner.
- ✓ The jack must have a load of 150 lb or more to lower with the handle movement. At loads below 150 lb, the lifting mechanism will slide down the rail to the base.
- ✓ Do not lift the vehicle more than necessary. Lifting higher than necessary may cause unexpected movement or tipping.
- ✓ Lower load slowly in controlled fashion. Do not allow load to drop quickly.
- ✓ Apply parking brake and chock tires before lifting vehicle.
- ✓ Do not use on curved or sloping vehicle surfaces. Jack will shift and load will drop. Use properly rated lifting strap when flat lifting surfaces do not exist.
- ✓ Inspect before every use; do not use if parts bent, loose, or damaged.
- ✓ No alternations shall be made to this product.
- ✓ Only attachments and/or adapters supplied by the manufacturer shall be used.

⚠ WARNING

This product can expose you to chemicals including Di(2-ethylhexyl)phthalate(DEHP), which is known to the State of California to cause cancer and birth defects or other reproductive harm. For more information go to www.P65Warnings.ca.gov.

⚠ WARNING

Contains lead. May be harmful if eaten or chewed. May generate dust containing lead. Keep out of the reach of children.

INSPECTION



This farm jack is designed only for lifting part of the total vehicle, do not move or dolly the vehicle while it is on the farm jack.

- Inspect the jack carefully before each use. Ensure the jack is not damaged, excessively worn, or missing parts.
- Do not use the jack unless it is properly lubricated.
- Using a jack that is not in good clean working condition or properly lubricated may cause serious injury.
- Inspect the work area before each use. Make sure it is free and clear of any potential hazards.

DO NOT OPERATE OR REPAIR THIS EQUIPMENT WITHOUT READING THIS MANUAL.

To maintain the Jack and user safety, the responsibility of the owner is to read and follow these instructions.

- Inspect the jack for proper operation and function.
- Keep instructions readily available for equipment operators.
- Make certain all equipment operators are properly trained; understand how to safely and correctly operate the unit.
- Allow unit operation only with all parts in place and operating properly.
- Service and maintain the unit only with authorized or approved replacement parts; negligence will make the jack unsafe for use and void the warranty.
- Carefully inspect the unit on a regular basis and perform all maintenance as required.
- Store this instruction manual in case of any use in the future.

SETUP-BEFORE USE

Before using this product, read the owner's manual completely and familiarize yourself thoroughly with the product and the hazards associated with its improper use. (Please refer to the below figure).

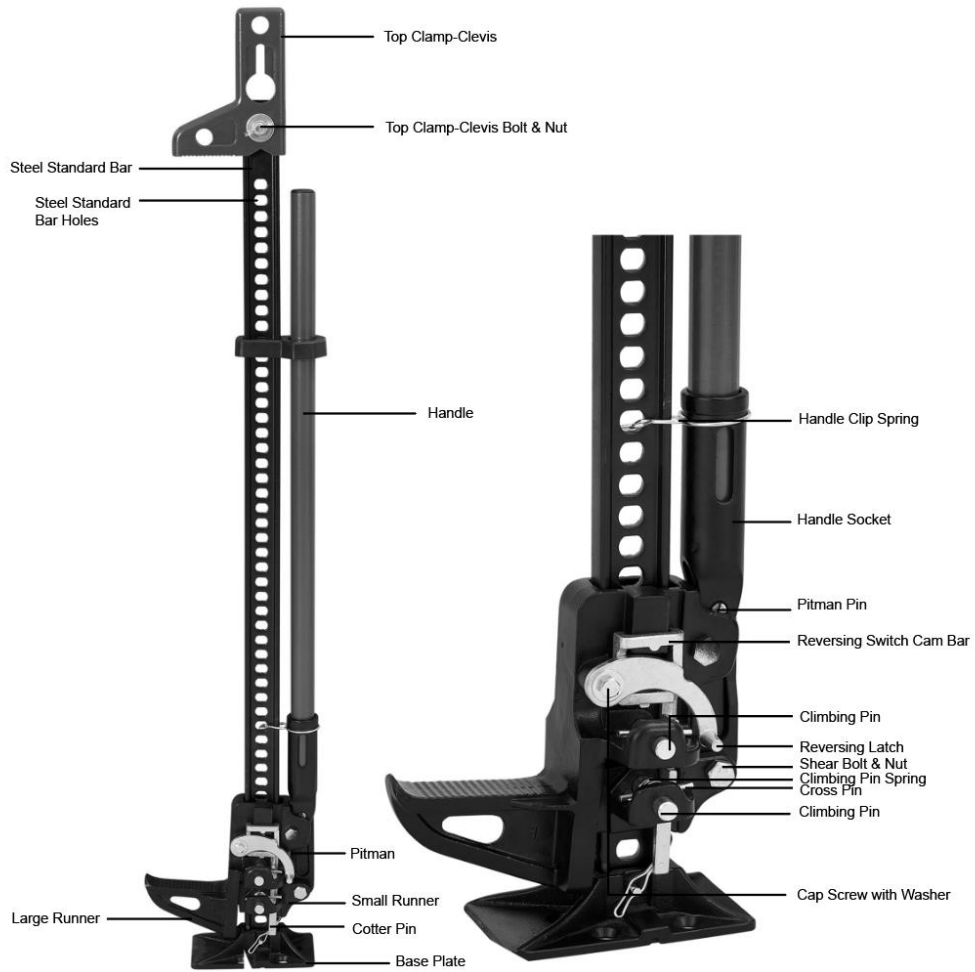

OPERATION

⚠ WARNING

Keep hand securely on Handle. During lifting and lowering, the weight of the load pushes up against the Jack Handle. If your hands slip off handle, or if handle is horizontal when moving the Reversing Latch, Handle may move very rapidly.

LIFTING:

⚠ WARNING

Do not use the Jack to support or stabilize load. Always securely chock and block (stabilize) load to be lifted.

- Chock and stabilize load securely to prevent rolling or shifting during lifting.
- Place Jack's base plate securely on a firm, level and dry surface with Steel Standard Bar pointing straight up.
- Lift the Reversing Latch until it locks in the up position.
- Pull the handle away from the Steel Standard Bar, and then release the Handle Clip Spring.
- Grasp the Handle and raise the Lifting Mechanism until the Large Runner is completely and securely under the load.
- Grasp the Handle firmly with both hands. Carefully pump Handle up and down to raise load. Do not use an extension on Handle.
- When the load is raised to desired height, place the Handle in the upright position, then clipped to the Steel Standard Bar.
- Block load securely. Lower load onto proper blocks or supports.
- Remove Jack from stabilized load.

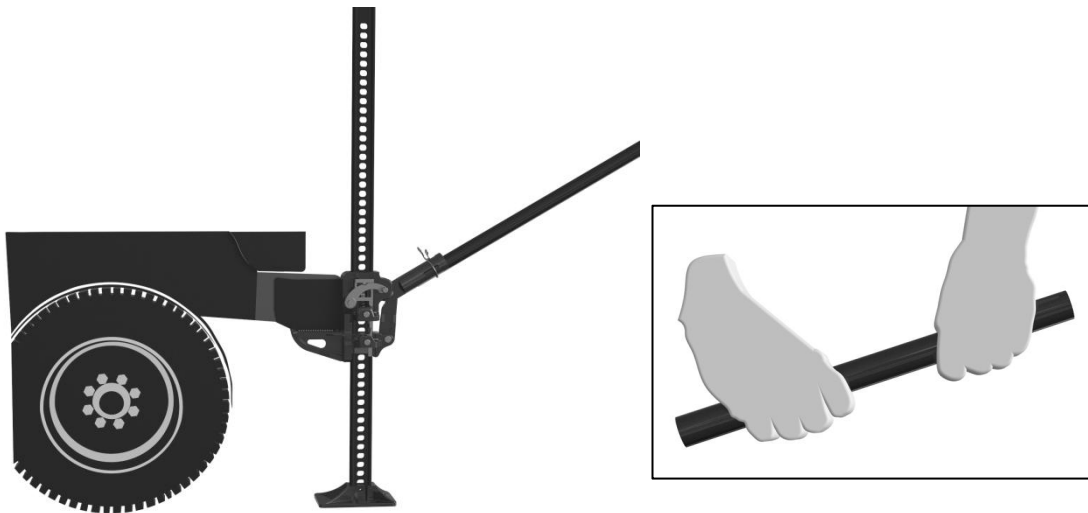

Note: The load will be raised on each down stroke of the handle. Watch the load and the Jack carefully. Stop lifting if either one starts to move. Do not continue until it is safe to do so. When safe, stabilize and block the load.

Note: Keep Handle against Steel Standard Bar with the Handle Clip Spring, holding it when not actively lifting or lowering.

⚠ WARNING

Do not use Jack for long-term support of a load.

LOWERING:

Note: Jack must have a load of at least 150 lb. If load is less than 150 lb., the Lifting Mechanism will slide down to the Base Plate, dropping your load.

- Position Jack under raised load and raise the stationary load high enough to remove blocks from under load. Note: Make sure load is stabilized before removing blocks.
- Place Handle in upright position clipped to Steel Standard Bar before lowering the load.
- Move Reversing Latch to the down position.
- Grasp Handle firmly with both hands. Carefully pump Handle to lower load.

Note: The load will be lowered on each up stroke of the Handle.

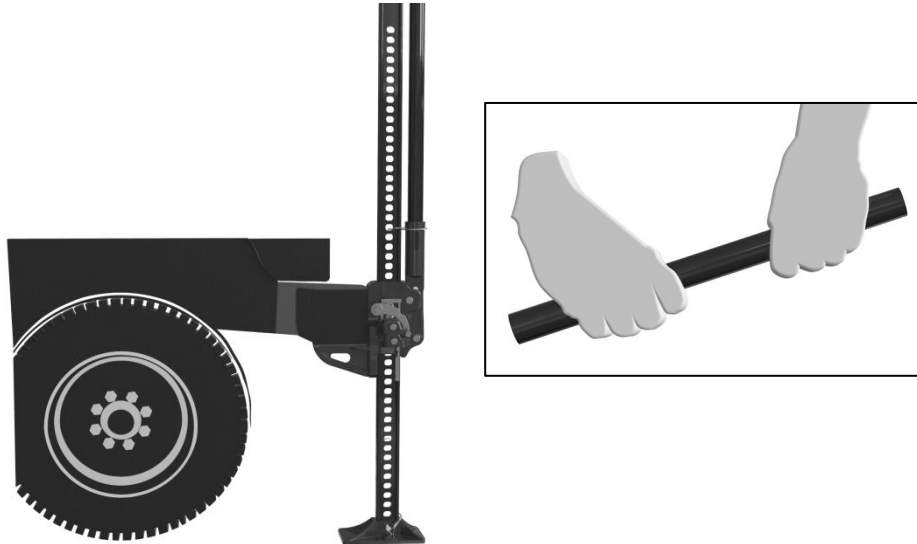

CLAMPING:

- Loosen the standard top Clamp-Clevis Bolt.
- Turn the top Clamp-Clevis 90 degrees to the Steel Standard Bar, and re-tighten Bolt.
- Operate Jack as you would for raising a load.
- Check **LIFTING** and **LOWERING** process on page 5&6.

Note: You can connect Clamp-Clevis Anywhere along the Steel Standard Bar to use the jack as a clamp.

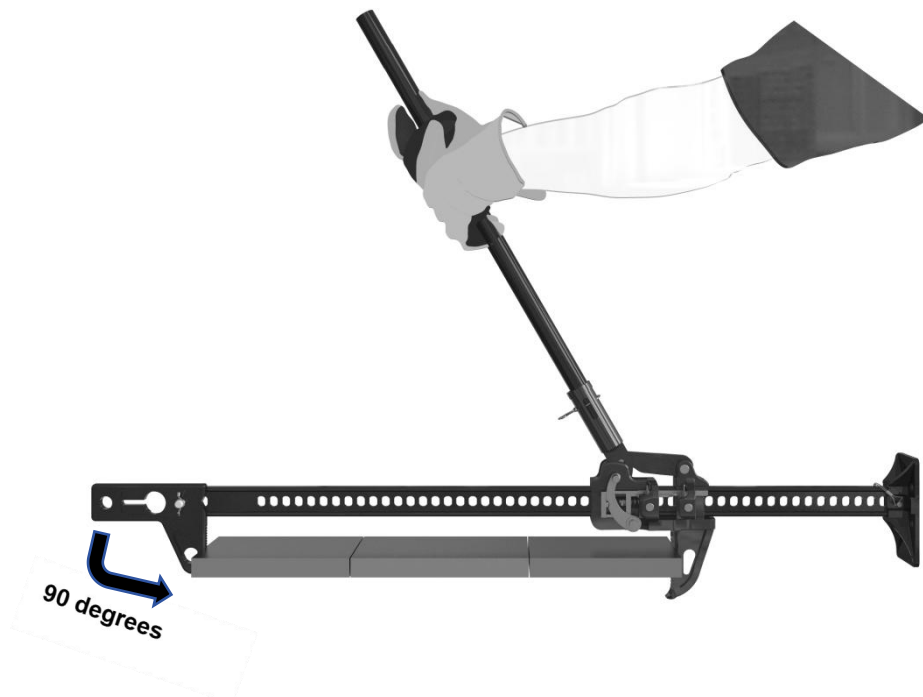

WINCHING:

- Make sure the top Clamp-Clevis is in line with Steel Standard Bar.
- Install one end of chain or tow strap (sold separately) securely to the object to be winched.
- Securely attach the other end of the chain or tow strap to the top Clamp-Clevis of the Jack.
- Take another chain or tow strap and secure one end to a fixed, stable object. Attach the other end of the chain or tow strap to the large Runner on the Jack.
- Operate Jack as you would for raising a load.
- Check **LIFTING** and **LOWERING** process on page 5&6.

⚠WARNING

Do not attach chain or tow strap to bottom hole of the large runner on the Jack!

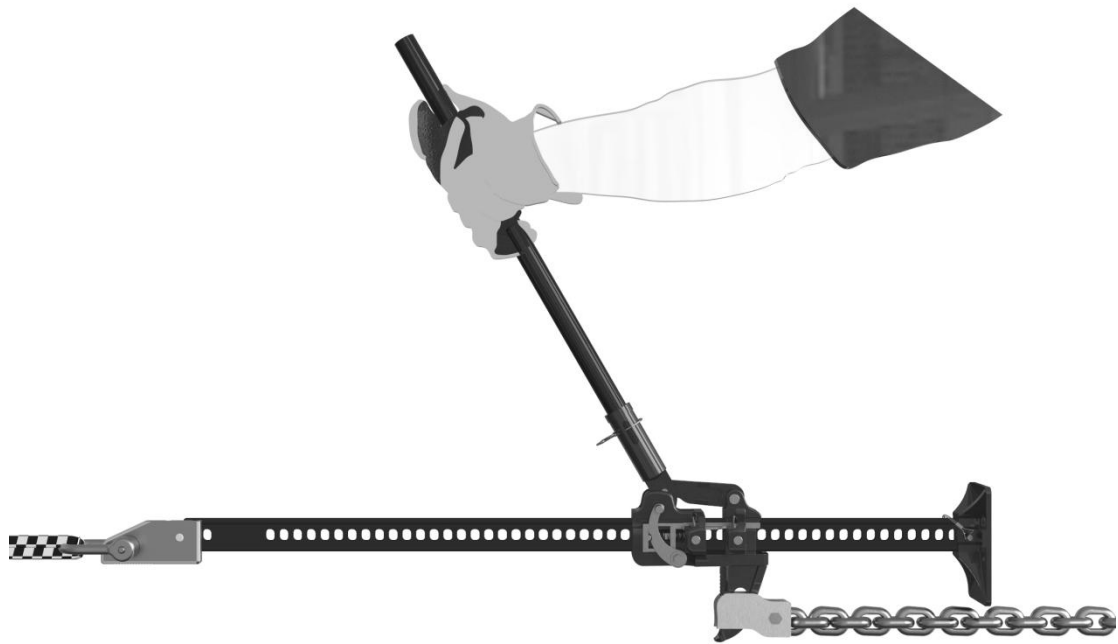

MAINTENANCE AND SERVICING



Procedures not specifically explained in this manual must be performed only by a qualified technician.

⚠WARNING

TO PREVENT SERIOUS INJURY FROM TOOL FAILURE: Do not use damaged equipment. If abnormal noise or vibration occurs, have the problem corrected before further use.

Cleaning, Maintenance, and Lubrication

Inspection before use

Before each use, inspect the general condition of the Jack. Check for broken, cracked, or bent parts, loose or missing parts, and any condition that may affect the proper operation of the product. If a problem occurs, have the problem corrected before further use. Do not use damaged equipment.

Cleaning

If the moving parts of the equipment are obstructed, use cleaning solvent or other good degreaser to clean the equipment. Remove any existing rust with a penetrating lubricant.

Lubrication

This equipment will not operate safely without proper lubrication. Using the equipment without proper lubrication will result in poor performance and damage to the equipment. Some parts in this equipment are not self-lubricating. Inspect the equipment before use and lubricate when necessary. After cleaning, lubricate the equipment using light penetrating oil, lubricating spray.

- Use a good lubricant on all moving parts.
- For light duty use, lubricate every six months.
- For heavy and constant use, monthly lubrication is recommended.
- **NEVER USE SANDPAPER OR ABRASIVE MATERIAL ON THESE SURFACES!**

Storing the Jack

Store in a dry location, recommended indoors.

Note: If the jack is stored outdoors, be sure to lubricate all parts before and after use to ensure the jack stays in good working condition. Always store jack in the fully retracted position when stored in outdoor or caustic environment that can cause corrosion and/or rust.

PARTS LIST AND ASSEMBLY DIAGRAM

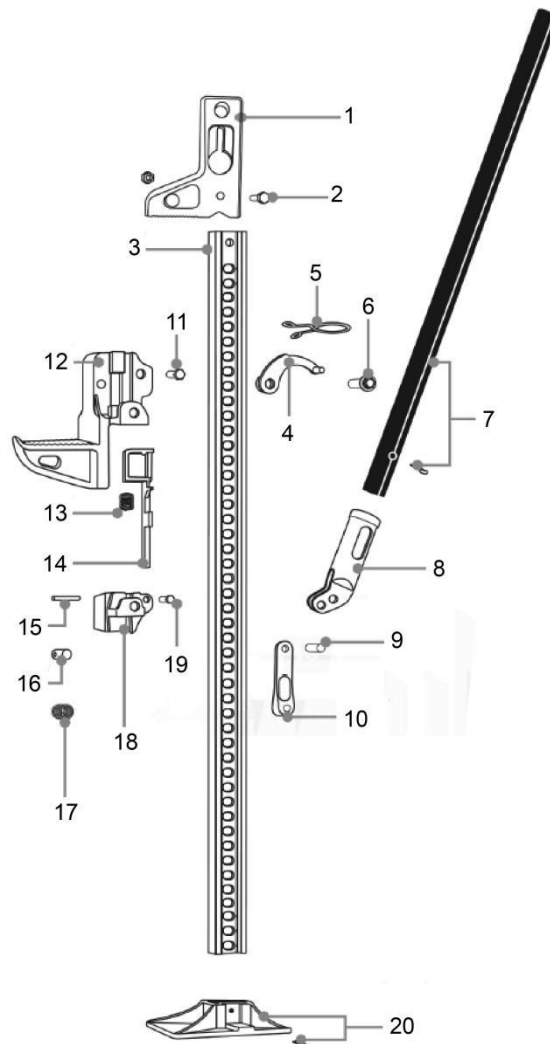

Item No.	Description	Qty	Item No.	Description	Qty
1	Top Clamp-Clevis	1	11	Hex Bolt and Nut	1
2	Top Clamp-Clevis Bolt and Nut	1	12	Lifting Arm/Large Runner	1
3	Steel Standard Bar	1	13	Reversing Switch Spring	1
4	Reversing Lever	1	14	Reversing Latch	1
5	Handle Clip Spring	1	15	Reverse Rod Pin	2
6	Cap Screw with Washer	1	16	Climbing Pin	2
7	Handle with Cotter Pin	1	17	Climbing Pin Spring	2
8	Handle Socket	1	18	Small Runner	1
9	Connecting Rod Pin	1	19	Hex Bolt and Nut	1
10	Connecting Rod	1	20	Base with Cotter Pin	1

⚠ WARNING

THE MANUFACTURER AND/OR DISTRIBUTOR HAS PROVIDED THE PARTS DIAGRAM IN THIS MANUAL AS A REFERENCE TOOL ONLY.

NEITHER THE MANUFACTURER NOR DISTRIBUTOR MAKES ANY REPRESENTATION OR WARRANTY OF ANY KIND TO THE BUYER THAT HE OR SHE IS QUALIFIED TO MAKE ANY REPAIRS TO THE PRODUCT OR THAT HE OR SHE IS QUALIFIED TO REPLACE ANY PARTS OF THE PRODUCT.

IN FACT, THE MANUFACTURER AND/OR DISTRIBUTOR EXPRESSLY STATES THAT ALL REPAIRS AND PARTS REPLACEMENTS SHOULD BE UNDERTAKEN BY CERTIFIED AND LICENSED TECHNICIANS AND NOT BY THE BUYER. THE BUYER ASSUMES ALL RISK AND LIABILITY ARISING OUT OF HIS OR HER REPAIRS TO THE ORIGINAL PRODUCT OR REPLACEMENT PARTS THERETO, OR ARISING OUT OF HIS OR HER INSTALLATION OF REPLACEMENT PARTS THERETO.

Distributed by:

TRACTOR SUPPLY COMPANY

5401 VIRGINIA WAY BRENTWOOD, TN 37027

For customer support

Call: 1-888-376-9601

www.TractorSupply.com

MADE IN CHINA