

GENMAX®

USER MANUAL



FOR MODELS:

GM12000E/GM12000ED

Portable Gasoline Generator

9000(GAS.)/8000(LPG) Running Watts | 10000(GAS.)/9000(LPG) Peak Watts

California

Proposition 65 Warning

The engine exhaust from this product contains chemicals known to the state of California to cause cancer, birth defects or other reproductive harm.

California

Proposition 65 Warning

Certain components in this product and its related accessories contain chemicals known to the state of California to cause cancer, birth defects or other reproductive harm. Wash hands after handling.

DISCLAIMERS:

All information, illustrations and specifications in this manual are based on the latest information available at the time of publishing. The illustrations used in this manual are intended as representative reference views only. Moreover, because of our continuous product improvement policy, we may modify information, illustrations and/or specifications to explain and/or exemplify a product, service or maintenance improvement. We reserve the right to make any change at any time without notice. Some images may vary depending upon which model is shown.

ALL RIGHTS RESERVED:

No part of this publication may be reproduced or used in any form by any means – graphic, electronic or mechanical, including photocopying, recording, taping or information storage and retrieval systems – without the written permission of CHONGQING DINKING POWER MACHINERY CO., LTD

DANGER



This manual contains important instructions for operating this inverter generator. For your safety and the safety of others, be sure to read this manual thoroughly before operating the generator. Failure to properly follow all instructions and precautions can cause you and others to be seriously hurt or killed.

TECHNICAL SPECIFICATIONS

Model Number	Running Watts	Peak Watts	Fuel Tank Size (Gal)	Rated Speed (RPM)	Ignition Type	Spark plug	Engine Disp (cc)	Stroke X Bore	Oil Capacity (Gal)	Oil Type
GM12000E	9000	10000	10.5	3600	CDI	A7RTC	458	92×69	0.3	10W30
GM12000ED	9000(GAS.) 8000(LPG)	10000(GAS.) 9000(GAS)	10.5	3600	CDI	A7RTC	458	92×69	0.3	10W30

LIMITED WARRANTY

1. **DURATION** : One (1) year from the date of purchase by the original purchaser (retail customer) on products used solely for consumer applications; if a product is used for business, commercial, or industrial applications, the warranty period will be limited to ninety (90) days from the date of purchase.
 2. **WHO GIVES THIS WARRANTY (WARRANTOR):**
CHONGQING DINKING POWER MACHINERY CO., LTD
 3. **WHO RECEIVES THIS WARRANTY(PURCHASER):**
The original purchaser (other than for purposes of resale) of the Genmax' s inverter.
 4. **WHAT PRODUCTS ARE COVERED BY THIS WARRANTY:**
Any portable generator supplied or manufactured by Warrantor.
 5. **WHAT IS COVERED UNDER THIS WARRANTY:**
Substantial defects on material and workmanship which occur within the duration of the warranty period.
 6. **WHAT IS NOT COVERED UNDER THIS WARRANTY:**
 - A. Transportation charges for sending the product to Warrantor or its authorized service representative for warranty service, or for shipping repaired or replacement products back to the customer; these charges must be borne by the customer.
 - B. Damages caused by abuse, accident, shipping, misuse, overloading, modification, and the effects of corrosion, erosion and normal wear and tear.
 - C. Warranty is voided if the customer fails to install, maintain and operate the product in accordance with the instructions and recommendations set forth in the owner's manual(s), or if the product is used as rental equipment.
 - D. Pre-delivery service, i.e. assembly, oil or lubricants, and adjustment.
 - E. Items or service that are normally required to maintain the product, i.e. lubricants and filters.
 - F. Warrantor will not pay for repairs or adjustments to the product, or for any costs or labour, performed without Warrantor's prior authorization.

EXCLUSIONS AND LIMITATIONS : Warrantor makes no other warranty of any kind, express or implied. Implied warranties, including warranties of merchantability and of fitness for a particular purpose, are hereby disclaimed. This warranty service described above is the exclusive remedy under this warranty; liability for incidental and consequential damages is excluded to the extent permitted by law.
 7. **RESPONSIBILITIES OF PURCHASER UNDER THIS WARRANTY:**
 - A. The purchaser must provide dated proof of purchase and must notify Warrantor within the warranty period.
 - B. Deliver or ship the serviced generator or component to the nearest Warrantor's authorized service representative. Freight costs, if any, must be borne by the purchaser.
 8. **HAVE QUESTIONS?**
Email: warrantiesmallengines@gmail.com Phone: 866-960-2920
-

WARRANTY CARD

PERSONAL INFORMATION

Name: _____

Street Address: _____

City, State, ZIP: _____

Country: _____

Phone Number: _____

E-Mail: _____

GENERATOR INFORMATION

Model Number: _____

Serial Number: _____

Date Purchased: _____

Purchased From: _____



TABLE OF CONTENTS

TECHNICAL SPECIFICATIONS	2	MAINTENANCE	16
LIMITED WARRANTY	3	Maintenance Schedule	16
Warranty Card	3	Engine Oil Maintenance	17
SAFETY	5	Checking Engine Oil	17
Safety Definitions	5	Adding Engine Oil	17
Safety Symbol Definitions	5	Changing Engine Oil	18
General Safety Rules	6	Air Filter Maintenance	18
Safety Labels and Decals	7	Cleaning the Air Filter	18
UNPACKING	7	Draining the Float Bowl	19
FEATURES	8	Spark Plug Maintenance	20
Basic Generator Features	8	Cleaning the Generator	21
Control Panel Features	9	Storage	21
OPERATION	11	TROUBLESHOOTING	22
Before Starting the Generator	11	SCHEMATICS	23
Location Selection	11		
Weather	11		
Dry Surface	11		
No Connected Loads	11		
Grounding the GENMAX Generator	11		
Powercord	12		
Generator Paralleling Operation	12		
Initial Oil Fill	13		
Adding/Checking Engine Fluids and Fuel	14		
Checking and/or Adding Engine Oil	14		
Adding Gasoline to the Fuel Tank	14		
Starting	15		
Stopping the Generator	15		

SAFETY

SAFETY DEFINITIONS

The words DANGER, WARNING, CAUTION and NOTICE are used throughout this manual to highlight important information. Be certain that the meanings of these alerts are known to all who work on or near the equipment.



This safety alert symbol appears with most safety statements. It means attention, become alert, your safety is involved! Please read and abide by the message that follows the safety alerts symbol.

DANGER

Indicates a hazardous situation which, if not avoided, *will* result in death or serious injury.

WARNING

Indicates a hazardous situation which, if not avoided, *could* result in death or serious injury.

CAUTION

Indicates a hazardous situation which, if not avoided, *could* result in minor or moderate injury.

NOTICE

Indicates a situation which can cause damage to the generator, personal property and/or the environment, or cause the equipment to operate improperly.

WARNING

Connection of the product to a building's electrical system is not applicable.

NOTE: Indicates a procedure, practice or condition that should be followed in order for the generator to function in the manner intended.

SAFETY SYMBOL DEFINITIONS

Symbol	Description
	Safety Alert Symbol
	Asphyxiation Hazard
	Burn Hazard
	Burst/Pressure Hazard
	Don't leave tools in the area
	Electrical Shock Hazard
	Explosion Hazard
	Fire Hazard
	Lifting Hazard
	Pinch-Point Hazard
	Read Manufacturer's Instructions
	Read Safety Messages Before Proceeding
	Wear Personal Protective Equipment (PPE)

SAFETY

GENERAL SAFETY RULES

DANGER



Never use the generator in a location that is wet or damp. Never expose the inverter to rain, snow, water spray or standing water while in use. Protect the inverter from all hazardous weather conditions. Moisture or ice can cause a short circuit or other malfunction in the electrical circuit.



Never operate the generator in an enclosed area. Engine exhaust contains carbon monoxide. Only operate the generator outside and away from windows, doors and vents.

WARNING



Voltage produced by the generator could result in death or serious injury.

- Never operate the generator in rain or a flood plain unless proper precautions are taken to avoid being subject to rain or a flood.
- Never use worn or damaged extension cords.
- Always have a licensed electrician connect the inverter to the utility circuit.
- Never touch an operating generator if the generator is wet or if you have wet hands.
- Never operate the generator in highly conductive areas such as around metal decking or steel works.
- Always use grounded extension cords. Always use three-wire or double-insulated power tools.
- Never touch live terminals or bare wires while the generator is operating.
- Be sure the generator is properly grounded before operating.

WARNING



Gasoline and gasoline vapors are extremely flammable and explosive under certain conditions.

- Always refuel the generator outdoors, in a well-ventilated area.
- Never remove the fuel cap with the engine running.
- Never refuel the generator while the engine is running. Always turn engine off and allow the generator to cool before refueling.
- Only fill fuel tank with gasoline.
- Keep sparks, open flames or other form of ignition (such as match, cigarette, static electric source) away when refueling.
- Never overfill the fuel tank. Leave room for fuel to expand. Overfilling the fuel tank can result in a sudden overflow of gasoline and result in spilled gasoline coming in contact with HOT surfaces. Spilled fuel can ignite. If fuel is spilled on the generator, wipe up any spills immediately. Dispose of rag properly. Allow area of spilled fuel to dry before operating the generator.
- Wear eye protection while refueling.
- Never use gasoline as a cleaning agent.
- Store any containers containing gasoline in a well-ventilated area, away from any combustibles or source of ignition.
- Check for fuel leaks after refueling. Never operate the engine if a fuel leak is discovered.

WARNING



Never operate the generator if powered items overheat, electrical output drops, there is sparking, flames or smoke coming from the generator, or if the receptacles are damaged.



Never use the generator to power medical support equipment.



Always remove any tools or other service equipment used during maintenance from the generator before operating.

NOTICE

Never modify the generator.

Never operate the generator if it vibrates at high levels, if engine speed changes greatly or if the engine misfires often.

Always disconnect tools or appliances from the generator before starting.

FEATURES

BASIC GENERATOR FEATURES

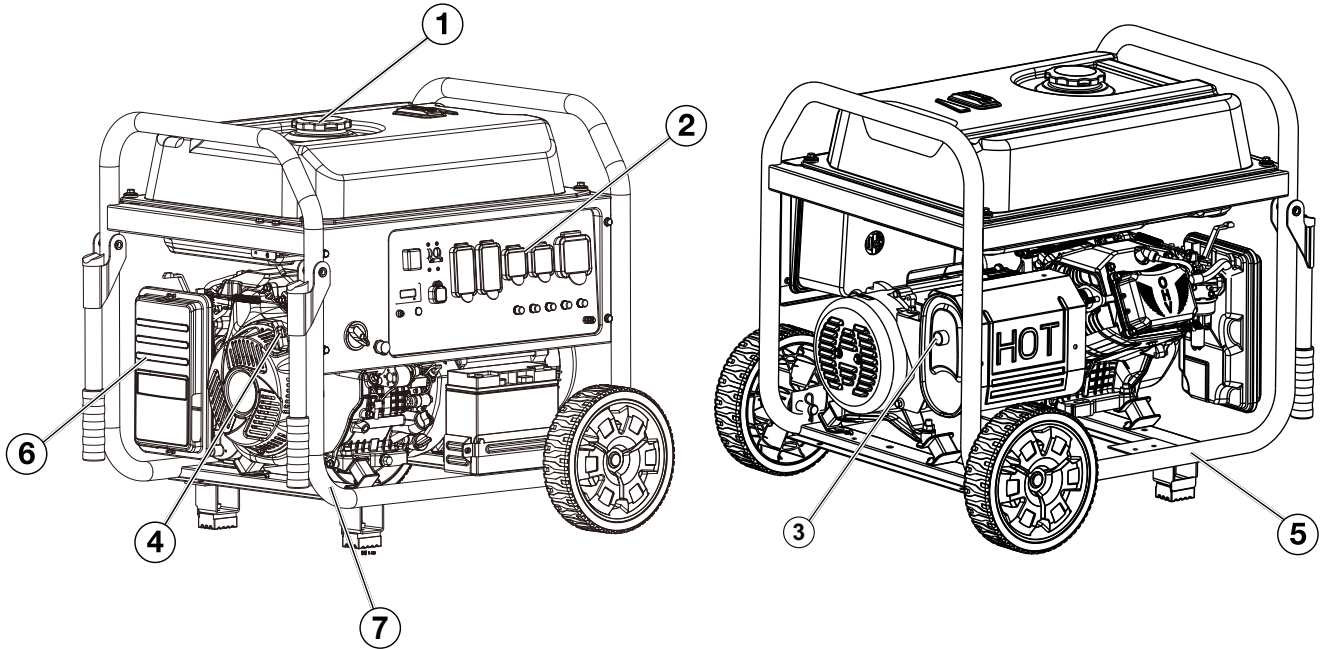

- ① **Fuel Cap:** Open the fuel tank cap and fill with proper amount of gasoline.
- ② **Control Panel:** Contains the reset breaker, outlets and warning lights.
- ③ **Muffler and Spark Arrestor:** Avoid contact until the engine is cooled down. The spark arrestor prevents sparks from exiting the muffler. It must be removed for servicing.
- ④ **Recoil Handle:** Pull to start the engine.
- ⑤ **Generator Rack:** Protects the generator for easy movement.
- ⑥ **Air Cleaner:** To purify the waste gas.
- ⑦ **Gas Inlet:** When using LPG, it is used to connect the gas pipe.

FEATURES

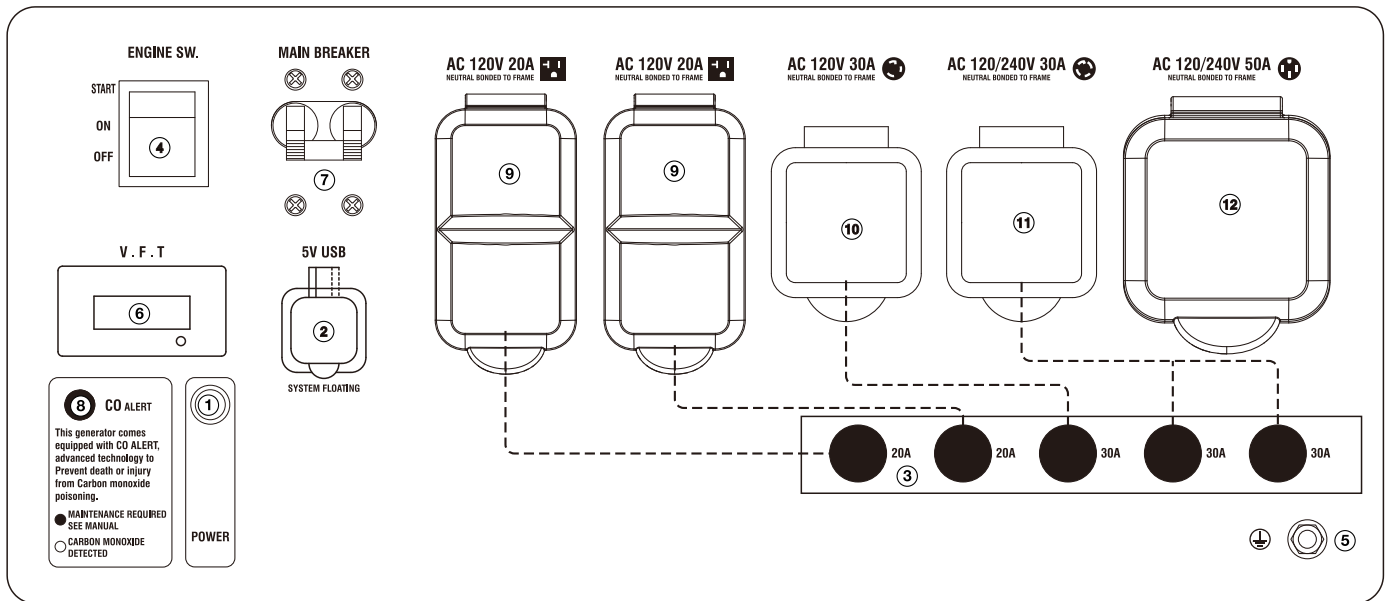

CONTROL PANEL FEATURES GM12000E

- ① **Power Indicator:** Indicates the generator is ready to be used.
- ② **USB Duplex:** 5V DC that come in 1 amps and 2.1 amps.
- ③ **AC Protector:** If the generator is overload, the AC protector will trip to block current.
- ④ **ENGINE SW.:** When the engine switch is set to "OFF", the generator cannot run. When the engine switch is set to "START" and the generator springs back to "ON", the generator starts.
- ⑤ **Ground Terminal:** The ground terminal is used to externally ground the generator.
- ⑥ **Three in one Digital Display Table:** Voltage, frequency, time display, press the button to switch.
- ⑦ **Main Breake:** A circuit breaker interrupts the current when the whole circuit is overloaded.
- ⑧ **CO Alarm LED:** Flashing red light: dangerous levels of carbon monoxide gas have built up leave immediately until area has aired out. Move generator to well-ventilated area before operation. Flashing yellow light: carbon monoxide sensor malfunction. Sensor needs service.
- ⑨ **120-Volt, 20-Amp Duplex Outlet:** The outlet is capable of carrying a maximum of 20 amps.
- ⑩ **120-Volt, 30-Amp Outlet:** The outlet is capable of carrying a maximum of 30 amps.
- ⑪ **120/240-Volt, 30-Amp Outlet:** The outlet is capable of carrying a maximum of 30 amps.
- ⑫ **120/240-Volt, 50-Amp Outlet:** The outlet is capable of carrying a maximum of 50 amps.

FEATURES

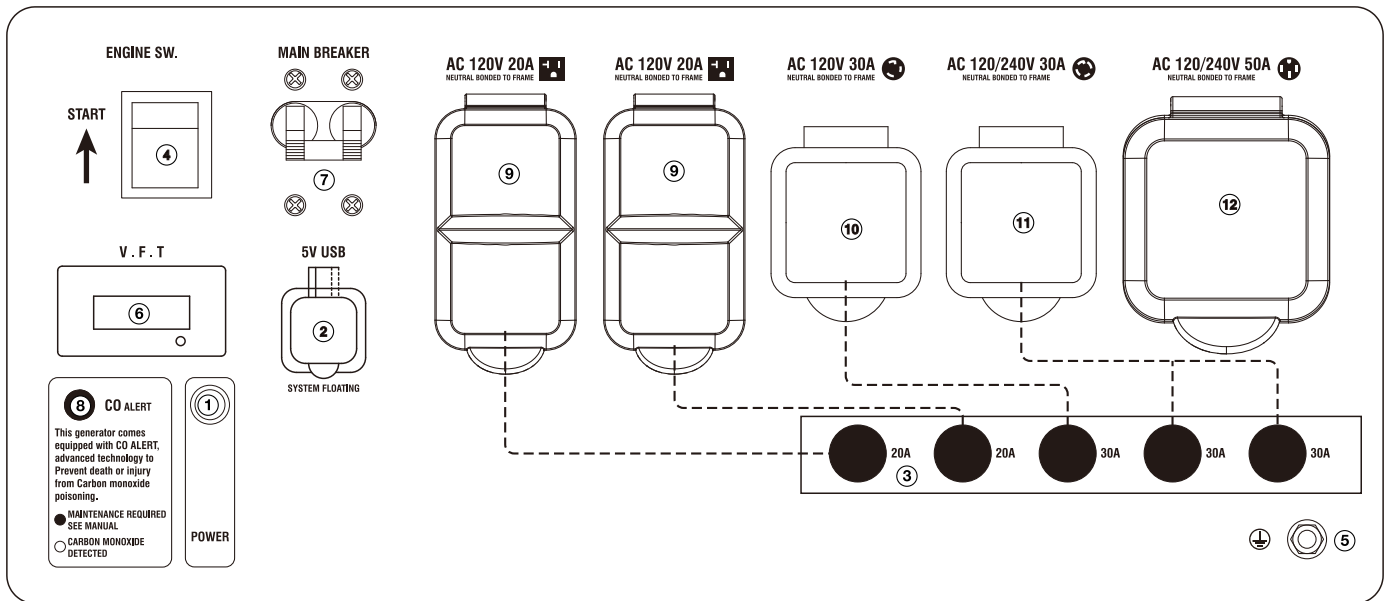

CONTROL PANEL FEATURES GM12000ED

- ① **Power Indicator:** Indicates the generator is ready to be used.
- ② **USB Duplex:** 5V DC that come in 1 amps and 2.1 amps.
- ③ **AC Protector:** If the generator is overload, the AC protector will trip to block current.
- ④ **Engine Switch:** Press "START" engine running, switch with rebound function.
- ⑤ **Ground Terminal:** The ground terminal is used to externally ground the generator.
- ⑥ **Three in one Digital Display Table:** Voltage, frequency, time display, press the button to switch.
- ⑦ **Main Breake:** A circuit breaker interrupts the current when the whole circuit is overloaded.
- ⑧ **CO Alarm LED:** Flashing red light: dangerous levels of carbon monoxide gas have built up leave immediately until area has aired out. Move generator to well-ventilated area before operation. Flashing yellow light: carbon monoxide sensor malfunction. Sensor needs service.
- ⑨ **120-Volt, 20-Amp Duplex Outlet:** The outlet is capable of carrying a maximum of 20 amps.
- ⑩ **120-Volt, 30-Amp Outlet:** The outlet is capable of carrying a maximum of 30 amps.
- ⑪ **120/240-Volt, 30-Amp Outlet:** The outlet is capable of carrying a maximum of 30 amps.
- ⑫ **120/240-Volt, 50-Amp Outlet:** The outlet is capable of carrying a maximum of 50 amps.

OPERATION

BEFORE STARTING THE GENERATOR



BEFORE STARTING THE GENERATOR, REVIEW SAFETY SECTION STARTING ON PAGE 5.

Location Selection – Before starting the generator, avoid exhaust and location hazards by verifying:

- You have selected a location to operate the generator that is outdoors and well ventilated.
- You have selected a location with a level and solid surface on which to place the generator.
- You have selected a location that is at least 6 feet (1.8 m) away from any building, other equipment or combustible material.
- If the generator is located close to a building, make sure it is not located near any windows, doors and/or vents.

⚠ DANGER	
<p>Using a generator indoors CAN KILL YOU IN MINUTES. Generator exhaust contains carbon monoxide. This is a poison you cannot see or smell.</p>	
<p>NEVER use inside a home or garage, EVEN IF doors and windows are open.</p>	<p>Only use OUTSIDE and far away from windows, doors, and vents.</p>
<p>Avoid other generator hazards. READ MANUAL BEFORE USE.</p>	

⚠ WARNING	
	<p>Always operate the generator on a level surface. Placing the generator on non level surfaces can cause the generator to tip over, causing fuel and oil to spill. Spilled fuel can ignite if it comes in contact with an ignition source such as a very hot surface.</p>

NOTICE	
<p>Only operate the inverter on a solid, level surface. Operating the generator on a surface with loose material such as sand or grass clippings can cause debris to be ingested by the inverter that could:</p> <ul style="list-style-type: none"> • Block cooling vents • Block air intake system 	

Weather – Never operate your generator outdoors during rain, snow or any combination of weather conditions that could lead to moisture collecting on, in or around the generator.

Dry Surface – Always operate the generator on a dry surface free of any moisture.

No Connected Loads – Make sure the generator has no connected loads before starting it. To ensure there are no connected loads, unplug any electrical extension cords that are plugged into the control panel receptacles.

NOTICE
<p>Starting the generator with loads already applied to it could result in damage to any appliance being powered off the generator during the brief start-up period.</p>

Grounding the GENMAX Generator
Consult with your local municipalities for your grounding codes.

⚠ WARNING	
	<p>Be sure the generator is properly connected to earth ground before operating.</p>

Carbon Monoxide Specification

CO DETECT technology monitors the accumulation of carbon monoxide (CO), a poisonous gas produced by engine exhaust when the generator is running. If CO Sensor detects unsafe elevated levels of CO gas, it automatically shuts off the engine. CO Sensor is not a substitute for an indoor carbon monoxide alarm or for safe operation. **DO NOT** allow engine exhaust fumes to enter a confined area through windows, doors, vents or other openings. Generators must **ALWAYS** be used outdoors, far away from occupied buildings with engine exhaust pointed away from people and buildings. Meets the requirements of ANSI/PGMA G300-2018.

OPERATION

POWERCORD

Using Extension Cords

GENMAX Portable Power assumes no responsibility for the content within this table. The use of this table is the responsibility of the user only. This table is intended for reference only. The results produced by using this table are not guaranteed to be correct or applicable in all situations as the type and construction of cords are highly variable. Always check with local regulations and a licensed electrician prior to installing or connecting an electrical appliance

Extension Cord Wire Gauge Size

AMPS	LENGTH OF EXTENSION CORD (ft)								
	10	20	30	40	50	60	80	100	120
5	20	18	16	14	12	12	10	10	8
10	18	16	14	12	12	10	10	8	8
15	16	14	12	12	10	10	8	8	6
20	14	12	12	10	10	8	8	6	6
25	12	12	10	10	8	8	6	6	6
30	12	10	10	8	8	6	6	6	6
35	10	10	8	8	6	6	6	6	6

INVERTER PARALLELING OPERATION

DANGER



Never connect the paralleling cord to the generator with the generator running. The generator must not be running and both the paralleling cord switches must be off when connecting the cords.

WARNING



Do not attempt to parallel the GENMAX generator with any other manufacturers' generator. Do not use the paralleling cord for any application other than generator paralleling. Do not use this cord on other manufacturers' generator.



Always ensure that both ends of the paralleling cord are switched off before connecting the generator.

GENERATOR PARALLELING OPERATION

1. Using only the GENMAX paralleling cord with both cord switches set to **OFF** (O), connect one male plug to one generator and connect the remaining plug into the other generator. Either of the receptacles on the generator can be used.
2. Start one of the generator and wait until the output ready light is on.
3. Turn both cord switches to ON (I).
4. Start the remaining generator; wait until the output ready light is on before connecting the load.
5. When power is present, a light will illuminate in the three-prong plug that is plugged into the generator.
6. To stop the generator, unplug all connected loads, turn both cord switches to **OFF** (O) and unplug the cord on each generator.
7. If during operation the generators' output is stopped due to overloading, reduce the connected load by unplugging appliances, and then push the reset button and restart the generator. When the ready light is on, the load can be reconnected.

OPERATION

INITIAL OIL FILL



BEFORE ADDING ENGINE OIL, REVIEW SAFETY SECTION STARTING ON PAGE 5.

NOTICE

Engine oil must be added when the generator is on a flat, level surface, or an inaccurate reading may result. Do not overfill. If the engine is overfilled with oil, it can cause serious engine damage.

1. Check the oil level and add oil to the appropriate position.(see Figure 1).

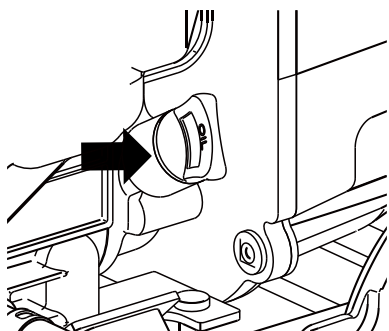

Figure 1: The oil plug

2. Clean the area around the oil fill/drain plug and remove plug (See Figure 2).

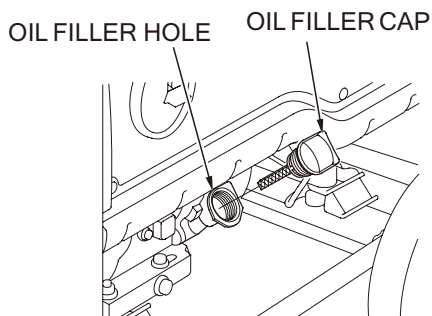

Figure 2: Oil Fill/Drain Plug

3. Using the supplied funnel and oil, pour the entire bottle of oil into the engine (see Figure 3).

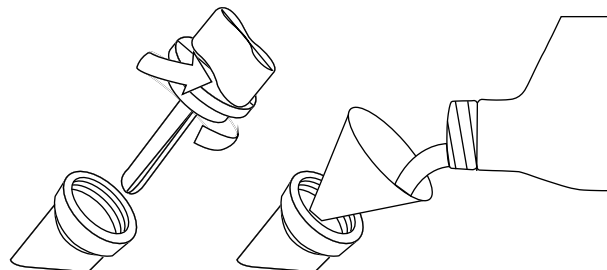

Figure 3: Oil Funnel

4. Do not overfill, if oil level is too high, oil will drain out through the fill plug. See correct oil level in Figure 4.

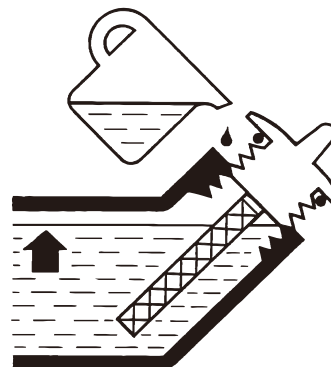

Figure 4: Engine Oil Correct Level

OPERATION

ADDING/CHECKING ENGINE FLUIDS AND FUEL



BEFORE ADDING/CHECKING ENGINE FLUIDS AND FUEL, REVIEW SAFETY SECTION STARTING ON PAGE 5.

DANGER



Filling the fuel tank with gasoline while the generator is running can cause gasoline to leak and come in contact with hot surfaces that can ignite the gasoline.

Before starting the generator, always check the level of:

- Engine oil
- Gasoline in the fuel tank

Once the generator is started and the engine gets warm, it is not safe to add gasoline to the fuel tank or engine oil to the engine while the engine is running or the engine and muffler are hot.

CHECKING AND / OR ADDING ENGINE OIL

WARNING



Internal pressure can build in the engine crankcase while the engine is running. Removing the oil fill plug/dipstick while the engine is hot can cause extremely hot oil to spray out of the crankcase and can severely burn skin. Allow engine oil to cool for several minutes before removing the oil fill plug/dipstick.

The unit as shipped does not contain oil in the engine. You must add engine oil before starting the generator for the first time. See *Initial Oil Fill* on page 13 for instructions on checking engine oil level and the procedure for adding engine oil.

NOTICE

The engine does not contain engine oil as shipped. Attempting to start the engine without adding engine oil will permanently damage internal engine components.

The engine is equipped with a low oil shutdown switch. If the oil level becomes low, the engine may shut down and not start until the oil is filled to the proper level.

The owner of the generator is responsible to ensure the proper oil level is maintained during the operation of the generator. Failure to maintain the proper oil level can result in engine damage.

ADDING GASOLINE TO THE FUEL TANK

WARNING



Never refuel the generator while the engine is running.



Always turn the engine off and allow the generator to cool before refueling.

CAUTION



Avoid prolonged skin contact with gasoline. Avoid prolonged breathing of gasoline vapors.

Required Gasoline – Only use gasoline that meets the following requirements:

- Unleaded gasoline only
- Gasoline with maximum 10% ethanol added
- Gasoline with an 87 octane rating or higher

Filling the Fuel Tank – Follow the steps below to fill the fuel tank:

1. Shut off the generator.
2. Allow the generator to cool down so all surface areas of the muffler and engine are cool to the touch.
3. Move the generator to a flat surface.
4. Clean area around the fuel cap.
5. Remove the fuel cap by rotating counterclockwise.

NOTICE

Do not overfill the fuel tank. Spilled fuel will damage some plastic parts.

6. Slowly add gasoline into the fuel tank. Be very careful not to overfill the tank. The gasoline level should NOT be higher than the red ring (see Figure 5).
7. Install the fuel cap by rotating clockwise.

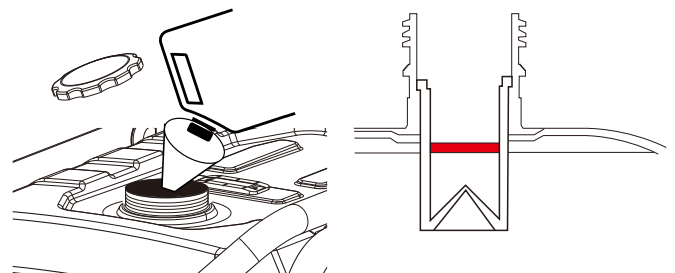

Figure 5: Maximum Gasoline Fill Level

OPERATION

STARTING THE GENERATOR



BEFORE STARTING THE GENERATOR, REVIEW SAFETY SECTION STARTING ON PAGE 5.

For proper starting and operation of the generator, make sure you review the generator features and their descriptions starting on page 8.

Before attempting to start the generator, verify the following:

- The engine is filled with engine oil (see Figure 4: Engine Oil Correct Level on page 13).
- The generator is situated in a proper location (see Location Selection on page 11).
- The generator is on a dry surface (see Weather and Dry Surface on page 11).
- All loads are disconnected from the generator (see No Connected Loads on page 11).
- The generator is properly grounded (see Grounding the Generator on page 11).

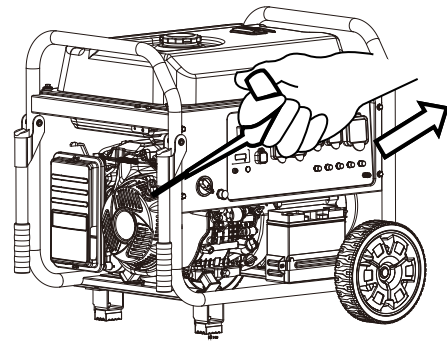

Figure 6: Pull the Recoil Handle out from Generator

Electric starting

1. Remove all the loads out of the output.
2. Turn the fuel valve to the "ON" position.
3. Turn the choke lever to the "CLOSED" position.
NOTICE: Don't close the choke when starting the engine in warm state.
4. Turn the generator switch to "START" position.
5. Turn the choke lever to the "OPEN" position after the engine is warm.

Fuel use and switching

1. When the fuel switch is turned to Petrol, follow the starting operation steps to normal use. When the fuel switch is turned off, the engine stops and flameout.
2. When the fuel switch is turned to Gas, follow the starting operation steps to normal use. When the fuel switch is turned off, the engine stops and flameout.
3. When the generator runs normally, it needs to switch from fuel oil to gas (or gas to fuel oil), and the generator must be rapidly rotated to petrol or gas in no-load state before it can be loaded and used normally.

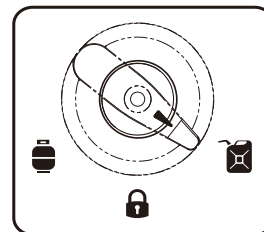

Open the fuel

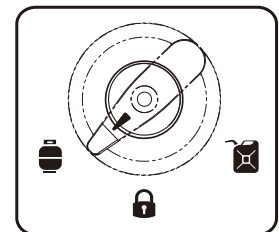

Open the gas

STOPPING THE INVERTER

Normal Operation

During normal operation, use the following steps to stop your generator:

1. Turn the AC circuit breaker to the "OFF" position.
2. Turn the generator switch to the "OFF" position.
3. Turn the fuel valve to the "OFF" position.

⚠ DANGER



Never use the generator in a location that is wet or damp. Never expose the generator to rain, snow, water spray or standing water while in use. Protect the generator from all hazardous weather conditions. Moisture or ice can cause a short circuit or other malfunction in the electrical circuit.



Never operate the generator in an enclosed area. Engine exhaust contains carbon monoxide. Only operate the generator outside and away from windows, doors and vents.

Recoil Starter

1. Remove all the loads out of the output.
2. Turn the fuel valve to the "ON" position.
3. Turn the choke lever to the "CLOSED" position.
NOTICE: Don't close the choke when starting the engine in warm state.
4. Pull the starter grip until compression is felt, then pull briskly (see Figure 6).
5. Turn the choke lever to the "OPEN" position after the engine is warm.

MAINTENANCE



BEFORE PERFORMING MAINTENANCE ON THE GENERATOR, REVIEW THE SAFETY SECTION STARTING ON PAGE 5, AS WELL AS THE FOLLOWING SAFETY MESSAGES.

⚠ WARNING	
	Avoid accidentally starting the generator during maintenance by removing the spark plug boot from the spark plug. For electric start generator, also disconnect the battery cables from the battery (disconnect the black negative (-) cable first) and place the cables away from the battery posts to avoid arcing.
	Allow hot components to cool to the touch prior to performing any maintenance procedure.
	Internal pressure can build in the engine crankcase while the engine is running. Removing the oil fill plug/dipstick while the engine is hot can cause extremely hot oil to spray out of the crankcase and can severely burn skin. Allow engine oil to cool for several minutes before removing the oil fill plug/dipstick.
	Always perform maintenance in a well-ventilated area. Gasoline fuel and fuel vapors are extremely flammable and can ignite under certain conditions.

⚠ CAUTION	
	Avoid skin contact with engine oil or gasoline. Prolonged skin contact with engine oil or gasoline can be harmful. Frequent and prolonged contact with engine oil may cause skin cancer. Take protective measures and wear protective clothing and equipment. Wash all exposed skin with soap and water.

⚠ WARNING	
	Failure to perform periodic maintenance or not following maintenance procedures can cause the generator to malfunction and could result in death or serious injury.

NOTICE	
Periodic maintenance intervals vary depending on generator operating conditions. Operating the generator under severe conditions, such as sustained high-load, high-temperature, or unusually wet or dusty environments, will require more frequent periodic maintenance. The intervals listed in the maintenance schedule should be treated only as a general guideline.	

Following the maintenance schedule is important to keep the generator in good operating condition. The following is a summary of maintenance items by periodic maintenance intervals.

TABLE 1: MAINTENANCE SCHEDULE - OWNER PERFORMED

Maintenance Item	Before Every Use	After First 20 Hours or First Month of Use	After 50 Hours of Use or Every 6 Months	After 100 Hour of Use or Every 6 Months	After 300 Hours of Use or Every Year
Engine Oil	Check Level	Change	Change	-	-
Cooling Features	Check/Clean	-	-	-	-
Air Filter	Check	-	Clean*	-	Replace
Spark Plug	-	-	-	Check/Clean	Replace
Spark Arrestor	-	-	-	Check/Clean	-

*Service more frequently if operating in dry and dusty conditions

MAINTENANCE

ENGINE OIL MAINTENANCE

Engine Oil Specification

1. Only use the engine oil specified in Figure 7.
2. Only use 4-stroke/cycle engine oil. **NEVER USE 2-STROKE/CYCLE OIL.** Synthetic oil is an acceptable substitute for conventional oil.

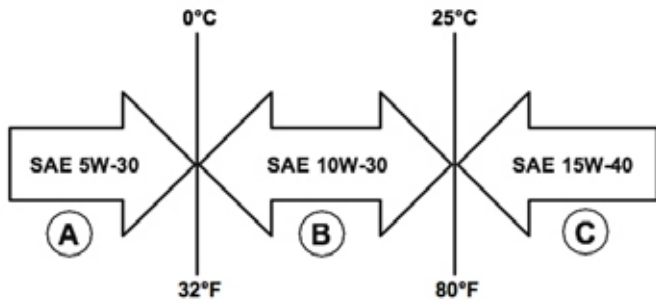

Figure 7: Recommended Oil

CHECKING ENGINE OIL

NOTICE

Always maintain proper engine oil level. Failure to maintain proper engine oil level could result in severe damage to the engine and/or shorten the life of the engine.

Always use the specified engine oil. Failure to use the specified engine oil can cause accelerated wear and/or shorten the life of the engine.

Engine oil level should be checked before every use.

1. Always operate or maintain the generator on a flat surface.
2. Stop engine if running.
3. Let engine sit and cool for several minutes (allow crankcase pressure to equalize).
4. Find the oil plug.
5. With a damp rag, clean around the oil fill/drain plug.
6. Remove the oil fill/drain plug.
7. Check oil level: When checking the engine oil, remove the oil fill/ drain plug.
 - The oil level is acceptable if oil is visible at the bottom of the threads of the oil fill plug.
 - If oil level is low, add to the correct level using the supplied oil fill bottle. Do not overfill the oil crankcase.

NOTICE

Engine oil must always be checked and added when the generator is on a flat, level surface, or an inaccurate reading may result, causing serious engine damage.

ADDING ENGINE OIL

1. Always operate or maintain the generator on a flat surface.
2. Stop engine if running.
3. Let engine sit and cool for several minutes (allow crankcase pressure to equalize).
4. Find the oil plug.
5. Thoroughly clean around the oil fill/drain plug.
6. Remove the oil fill/drain plug.
7. Select the proper engine oil as specified in Figure 8.
8. Using the supplied oil funnel, slowly add engine oil to the engine. Stop frequently to check the oil level and avoid overfilling.

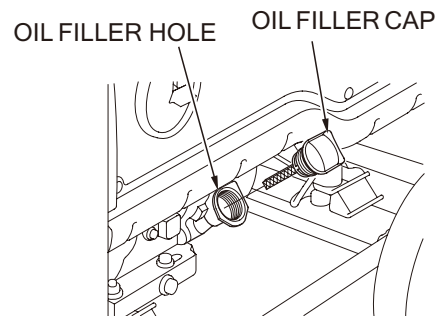

9. Continue to add oil until the oil is at the correct level.

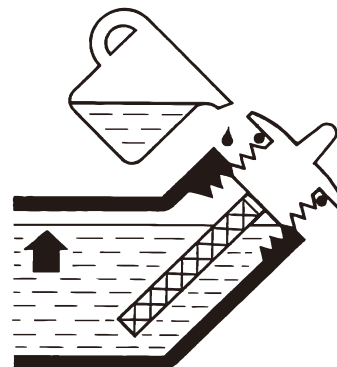

MAINTENANCE

CHANGING ENGINE OIL

Drain the oil while the engine is warm to assure complete and rapid draining.

1. Remove the oil dipstick and drain plug to drain the oil.
2. Reinstall the drain plug, then tighten the plug securely.
3. Refill oil and check the oil level.

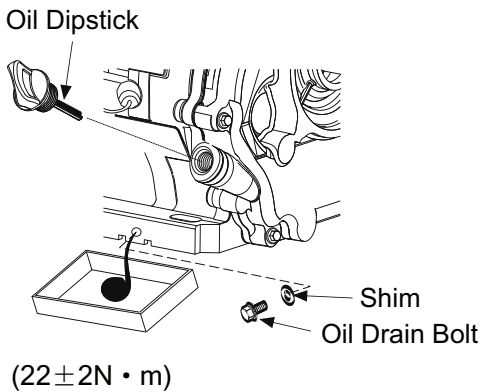

Figure 8: Place oil pan under oil fill/drain plug

NOTICE

Never dispose of used engine oil by dumping the oil into a sewer, on the ground, or into groundwater or waterways. Always be environmentally responsible. Follow the guidelines of the EPA or other governmental agencies for proper disposal of hazardous materials. Consult local authorities or reclamation facility.

AIR FILTER MAINTENANCE

WARNING



Never use gasoline or other flammable solvents to clean the air filter. Use only household detergent soap to clean the air filter.

Cleaning the Air Filter

The air filter must be cleaned after every 50 hours of use or 3 months (frequency should be increased if inverter is operated in a dusty environment).

1. Open the air cleaner clip and open the air cover. Check the air cleaner element for complete and clean (see Figure 9).
2. If the air cleaner element is dirt, please clean the air cleaner element.

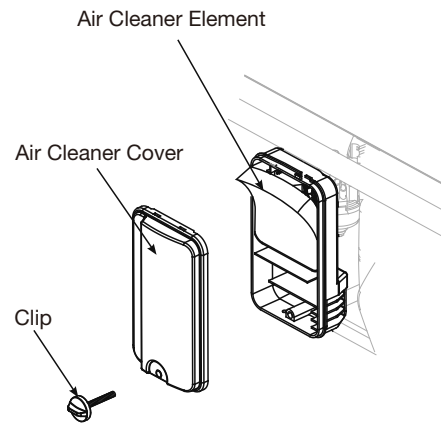

Figure 9: Unscrew air cleaner cover

3. Wash the foam air filter element by submerging the element in a solution of household detergent soap and warm water. Slowly squeeze the foam to thoroughly clean.

NOTICE

NEVER twist or tear the foam air filter element during cleaning or drying. Only apply slow but firm squeezing action.

MAINTENANCE

4. Rinse in clean water by submerging the air filter element in fresh water and applying a slow squeezing action (see Figure 10).



Figure 10

NOTICE

Never dispose of soap cleaning solution used to clean the air filter by dumping the solution into a sewer, on the ground, or into ground water or waterways. Always be environmentally responsible. Follow the guidelines of the EPA or other governmental agencies for proper disposal of hazardous materials. Consult local authorities or reclamation facility.

5. Dispose of used soap cleaning solution properly.
6. Dry the air filter element by again applying a slow firm squeezing action.
7. Return the air filter element to its position in the air cleaner housing.
8. Install the air cleaner cover, making sure the tabs lock into place.

DRAINING THE FLOAT BOWL

1. Find the carburetor.
2. Connect the transparent plastic hose and place a suitable container under it to capture the spent fuel (see Figure 11).

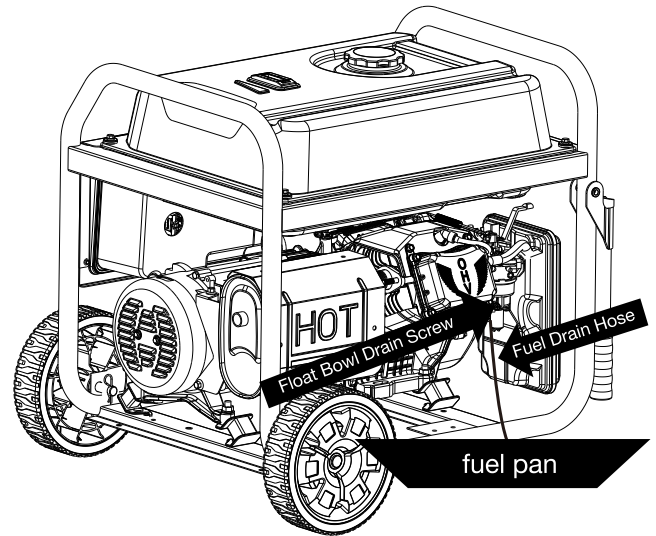

Figure 11: Fuel drain hose

3. Loosen the float bowl drain screw (see Figure 12) until fuel is seen draining from the float bowl.

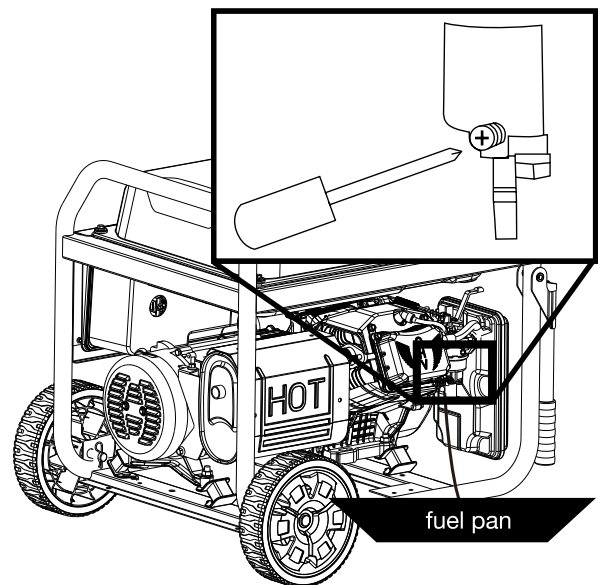

Figure 12: Loosen float bowl screw

4. Allow fuel to drain into the container, and then tighten the float bowl drain screw.

NOTICE

Never dispose of fuel by dumping fuel into a sewer, on the ground, or into groundwater or waterways. Always be environmentally responsible. Follow the guidelines of the EPA or other governmental agencies for proper disposal of hazardous materials. Consult local authorities or reclamation facility.

MAINTENANCE

SPARK PLUG MAINTENANCE

The spark plug must be checked and cleaned after every 100 hours of use or 6 months and must be replaced after 300 hours of use or every year.

1. Stop the generator and let it cool for several minutes if running.
2. Move the generator to a flat, level surface.

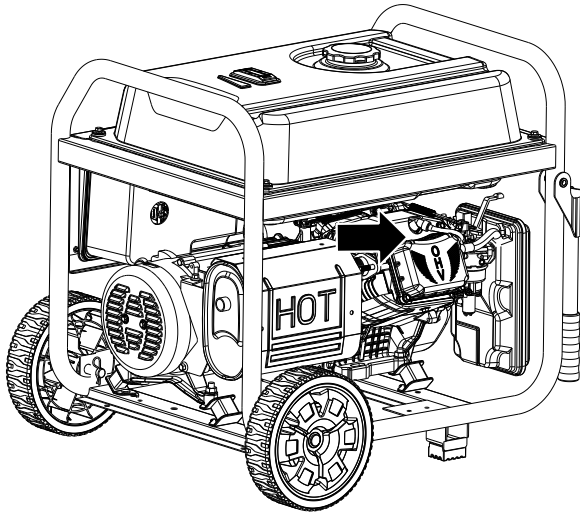

Figure 13: Slide off spark plug cover

3. Remove the spark plug boot by firmly pulling the plastic spark plug boot handle directly away from the engine (see Figure 13).

NOTICE

Never apply any side load or move the spark plug laterally when removing the spark plug. Applying a side load or moving the spark plug laterally may crack and damage the spark plug boot.

5. Clean area around the spark plug.
6. Using the spark plug socket wrench provided, remove the spark plug from the cylinder head (see Figure 14).

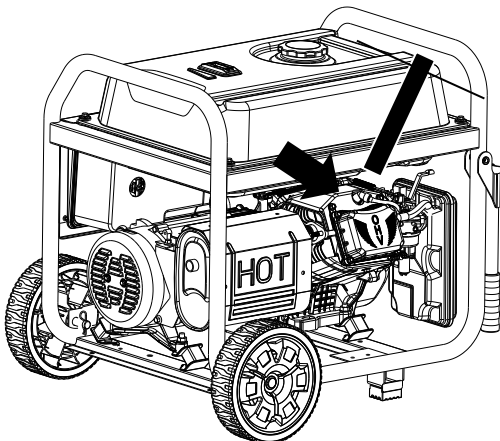
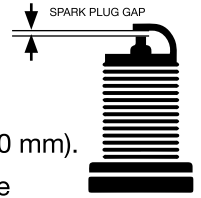

Figure 14: Remove spark plug with socket wrench

7. Place a clean rag over the opening created by the removal of the spark plug to make sure no dirt can get into the combustion chamber.

8. Inspect the spark plug for:

- Cracked or chipped insulator
- Excessive wear
- Spark plug gap of 0.032 in. (0.80 mm).



If the spark plug fails any one of the conditions listed above, replace the plug.

NOTICE

Only use the recommended spark plug. See chart below. Using a non-recommended spark plug could result in damage to the engine.

9. Install the spark plug by carefully following the steps outlined below:
 - a. Carefully insert the spark plug back into the cylinder head. Hand-thread the spark plug until it bottoms out.
 - b. Using the spark plug socket wrench provided, turn the spark plug to ensure it is fully seated.
 - c. Replace the spark plug boot, making sure the boot fully engages the spark plug's tip.

MAINTENANCE

CLEANING THE GENERATOR

It is important to inspect and clean the generator before every use.

Clean All Engine Air Inlet and Outlet Ports – Make sure all engine air inlet and outlet ports are clean of any dirt and debris to ensure the engine does not run hot.

STORAGE

WARNING



Never store an generator with fuel in the tank indoors or in a poorly ventilated area where the fumes can come in contact with an ignition source such as a: 1) pilot light of a stove, water heater, clothes dryer or any other gas appliance; or 2) spark from an electric appliance.

NOTICE

Gasoline stored for as little as 60 days can go bad, causing gum, varnish and corrosive buildup in fuel lines, fuel passages and the engine. This corrosive buildup restricts the flow of fuel, preventing an engine from starting after a prolonged storage period.

Proper care should be taken to prepare the generator for any storage

1. Clean the generator as outlined in Cleaning the Generator.
2. Siphon all gasoline from the fuel tank as best as possible.
3. Start the engine and allow the generator to run until all the remaining gasoline in the fuel lines and carburetor is consumed and the engine shuts off.
4. Drain any remaining fuel from the float bowl. See Draining the Float Bowl on page 19.
5. Change the oil (see Changing Engine Oil on page 18).
6. Remove the spark plug (see Spark Plug Maintenance on page 20) and place about 1 tablespoon of oil in the spark plug opening. While placing a clean rag over the spark plug opening slowly pull the recoil handle to allow the engine to turn over several times. This will distribute the oil and protect the cylinder wall from corroding during storage.
7. Replace the spark plug (see Spark Plug Maintenance on page 20).
8. Move the generator to a clean, dry place for storage.

TROUBLESHOOTING

⚠ WARNING



Before attempting to service or troubleshoot the generator, the owner or service technician must first read the owner's manual and understand and follow all safety instructions. Failure to follow all instructions may result in conditions that can lead to voiding of the EPA certification or product warranty, serious personal injury, property damage or even death.

PROBLEM	POTENTIAL CAUSE	SOLUTION
Engine is running, but no electrical output.	1. Reset breaker is tripped.	1. Reset the reset breaker.
	2. The power cord's plug connector is not fully engaged in the generator's outlet.	2. Verify plug connector is firmly engaged in the generator outlet.
	3. Faulty or defective power cord	3. Replace power cord.
	4. Faulty or defective electrical appliance	4. Try connecting a known good appliance to verify the generator is producing electrical power.
Engine will not start or remain running while trying to start.	1. Generator is out of gasoline.	1. Add gasoline to the generator (see page 14).
	2. Fuel flow is obstructed.	2. Inspect and clean fuel delivery passages.
	3. Dirty air filter	3. Check and clean the air filter (see page 18).
	4. Low oil level shutdown switch is preventing the unit from starting.	4. Check oil level and add oil if necessary (see page 17).
	5. Spark plug boot is not fully engaged with the spark plug tip.	5. Firmly push down on the spark plug boot to ensure the boot is fully engaged.
	6. Spark plug is faulty.	6. Remove and check the spark plug. Replace if faulty (see pages 20).
	7. Dirty/plugged spark arrestor	7. Check and clean the spark arrestor (see page 21).
	8. Stale fuel	8. Drain fuel and replace with fresh fuel.
Generator suddenly stops running.	1. Generator is out of fuel.	1. Check fuel level (see page 14). Add fuel if necessary.
	2. The low oil shut down switch has stopped the engine.	2. Check oil level and add oil if necessary (see page 17).
	3. Too much load	3. Restart the generator and reduce the load.
Engine runs erratic; does not hold a steady RPM.	1. Choke was left in the CHOKE position.	1. Move choke to the RUN position
	2. Dirty air filter	2. Clean the air filter (see page 18).
	3. Applied loads maybe cycling on and off	3. As applied loads cycle, changes in engine speed may occur; this is a normal condition.

GM12000E SCHEMATICS

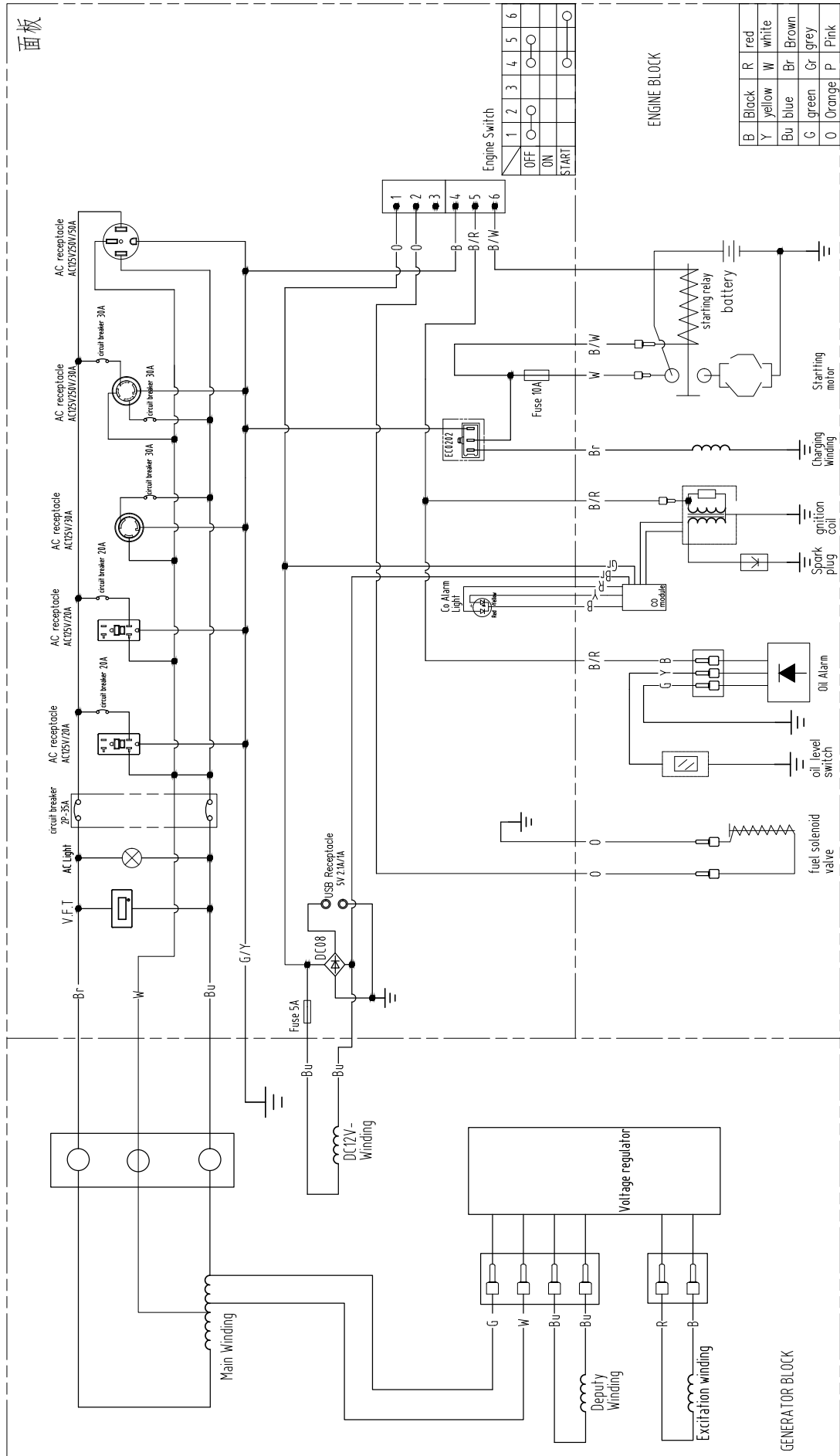

GENMAX®

**CHONGQING DINKING POWER MACHINERY CO.,LTD.
CAOJIE DEVELOPMENT AREA, INDUSTRIAL PARK, HECHUAN, CHONGQING, CHINA**

6800.560.GEM.02.00 V1