

# OPTIMUS

## INSTRUCTION MANUAL AND OWNER'S GUIDE

### 3.0 Gallon Cool Mist Evaporative Tower Humidifier With Antimicrobial Treated Wick

Model U-33100

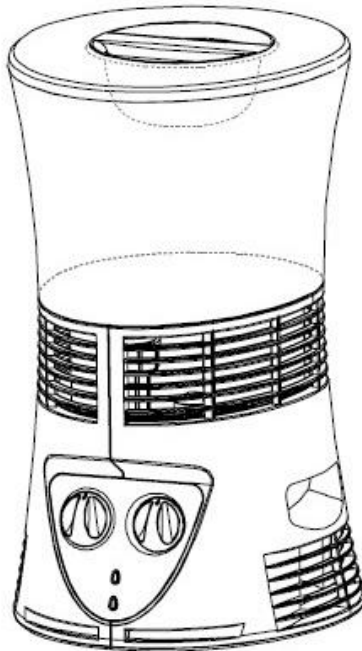

**INFORMATION HOT LINE:** If you have any questions or comments, please feel free to e-mail us at [service.optimus@gmail.com](mailto:service.optimus@gmail.com) or call us at 1-888-672-5832. Our customer service representative will be happy to help you. E-mail is the best way to reach us.

**PLEASE READ AND SAVE THESE INSTRUCTIONS**

### IMPORTANT INSTRUCTIONS:

#### PLEASE READ AND SAVE THESE IMPORTANT SAFEGUARDS

Thank you for choosing an Optimus humidifier. To ensure the best performance from your product, please read and save the following instructions.

WHEN USING ELECTRICAL APPLIANCES, BASIC PRECAUTIONS SHOULD ALWAYS BE FOLLOWED TO REDUCE THE RISK OF FIRE, ELECTRIC SHOCK AND INJURY TO PERSON, INCLUDING THE FOLLOWING:

- Read all instructions before using this humidifier.
- To avoid electrical shock or fire, be sure to plug into a 120v AC outlet only. Make sure the plug is fully inserted. **A loose fit between the AC outlet and plug may cause over heating of the plug. Have a qualified electrician replace the old outlet if the power cord becomes extremely hot.**
- The power cord has a polarized AC plug, which will fit into the outlet one way only (one blade is wider than the other). If the plug will not insert fully into the outlet, try reversing the plug. If the plug still fails to fit, have an electrician replace the old outlet. Never alter the plug to fit into an obsolete outlet. Doing so may compromise safety.
- This humidifier is for indoor use only. Do not use in wet or damp locations such as bathrooms, laundry areas or other similar indoor locations. Never locate humidifier where it may fall into a bathtub or other water container.
- Avoid the use of an extension cord to avoid overheating or risk of fire. However, if you must use an extension cord, the cord shall be No. 14AWG minimum size and rated no less than 1875 watts.
- Do not run cord under carpet, throw rugs, runners or the like. Arrange cord away from traffic area where it might be tripped over.
- Do not use this product if parts are missing. Do not use this unit if the power cord shows signs of damage or wear or if the unit has been dropped or misused.
- **Place this humidifier on a water-resistant and flat level surface only.** This unit may not function properly or water may spill if it is placed on an uneven surface.
- Be sure to turn off and unplug this unit when cleaning or not in use.
- Never tip or move the humidifier while operating or while water is in the base or tank.
- This humidifier is not to be serviced or repaired by anyone except the manufacturer or service/ repair facilities authorized by the manufacturer. Never disassemble your humidifier. Doing so may void your warranty.
- Do not use this humidifier with timers or any other automatically controlled devices.
- Use this humidifier in the manner described in this operation manual only. Fail to follow this manual may cause damage to the humidifier, fire hazard, electrical shock, or injury to persons or property.
- Do not place this humidifier near furnaces, heaters, stoves, or any other source of heat.
- Position this humidifier out of the reach of children and pets. Extreme caution is necessary when this unit is used by or near children or persons with reduced physical, sensory or mental capabilities, or whenever the unit is left operating and unattended.
- Turn off the humidifier if relative humidity exceeds 60%.
- Never block the mist outlet.
- Do not cover any part of this humidifier. Do not insert any object into any area of this humidifier.
- **Do not attempt to use this humidifier without the wick.**
- **This humidifier requires periodic maintenance.** Refer to the cleaning instructions in this manual.
- **Do not use anything other than water in this humidifier. Do not use additives.**

## GETTING TO KNOW YOUR HUMIDIFIER:

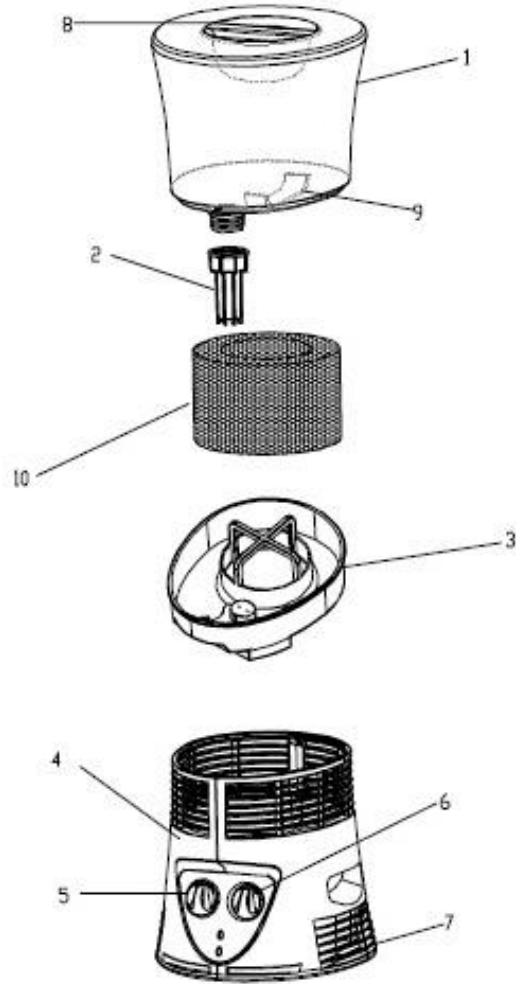

- |                       |                                         |
|-----------------------|-----------------------------------------|
| 1. Tank               | 6. Power Control Knob                   |
| 2. Cap                | 7. Mist Outlets (located on both sides) |
| 3. Tray               | 8. Tank Carry Handle (top)              |
| 4. Housing            | 9. Tank Carry Handle (bottom)           |
| 5. Humidistat Control | 10. Wick                                |

## INTRODUCTION

Congratulations on your purchase of your new Optimus Premium Cool Mist Tower Humidifier. This patented humidifier utilizes evaporative (cool mist) technology to produce comfortable, soothing humidity.

## ADVANTAGES OF MAINTAINING PROPER MOISTURE LEVELS

Dry indoor air can be uncomfortable and damaging to people, pets, plants and belongings. Proper moisture levels can help alleviate or prevent:

- |                                      |                                |
|--------------------------------------|--------------------------------|
| * Stuffy, dry nasal passages         | * Dry plants, flowers          |
| * Dry coughs and irritated throats   | * Static electricity           |
| * Parched lips and itchy, flaky skin | * Dry, cracking wood furniture |

## HOW YOUR HUMIDIFIER WORKS

Water flows from the tank into the tray. Water is absorbed by the wick. A fan draws ambient air through the wet wick and expels comfortable, soothing, invisible moisture into the air. During this process minerals and impurities in the water are trapped in the wick.

## PRE-OPERATING INSTRUCTIONS

Locate an appropriate level flat surface near an electrical outlet for placement of your humidifier. When placing on the floor **do not place on shag, carpet or rug**. Doing so may create an uneven surface. Be sure to **place your humidifier on a water-resistant surface and away from furniture and electronic appliances since water can cause damage to furniture and other possessions**. Position your humidifier so that the electrical cord and the humidifier do not become a trip hazard. **To ensure proper ventilation be sure to keep all sides and top of your humidifier at least 12 inches from walls or any objects.**

## SETUP

Turn the tank upside-down and remove the cap by turning it counter-clockwise. Fill the tank with cold water. We recommend using distilled or filtered water and avoid hard water. **Do not use hot water or additives.** Replace the cap by turning it clockwise; be sure not to over-tighten it. Turn the tank upright and position the tank back to the housing. Be sure the tank is seated properly in the housing and the valve is open. Water will begin flowing from the tank into the tray.

**NOTE:** Be sure to align the locator tab near the front on the outer rim of the tank to the recess on the front rim of the housing.

## OPERATION

With the Power Control Knob in the OFF position, plug the humidifier into a polarized 120VAC outlet

**NOTE:** The Power cord has a polarized AC plug, which will fit into the outlet one way only (one blade is wider than the other). If the plug does not insert fully into the outlet, try reversing the plug. If the plug still fails to fit, call an electrician to replace the old outlet. Never alter the plug to fit into an obsolete outlet. Doing so may compromise safety. **Do not attempt to plug the humidifier into the outlet with wet hands, as electrical shock may occur.**

- Turn the Humidistat Control Knob to the MAX position.
- Turn the Power Control Knob to your desired setting, HIGH, MED or LOW.
- Comfortable, soothing, invisible moist air will be produced immediately.
- The Humidistat can be adjusted to your desired setting. When the humidity in the vicinity reaches the setting of the Humidistat, the HUMIDITY light will disappear and the humidifier will stop operating. When the humidity in the vicinity falls below the Humidistat setting, the humidifier will start operating again automatically and the HUMIDITY light will illuminate. This ON/OFF cycle will continue as long as the humidifier is in use.
- For continuous operation turn the Humidistat Control Knob to the MAX position (far right). Do not force the Humidistat Control Knob past the MAX position. Doing so will damage the humidifier.

## REFILLING THE TANK

When the tank is empty and the water reaches a minimum level in the tray, the humidifier will automatically shut down and stop producing moisture.

Turn off and unplug the humidifier. Refill the tank with cool water, for best results, use distilled or filtered water. **Do not use hot water or chemical additives.** Properly replace the tank, plug into an outlet and turn the humidifier on. Comfortable, soothing, invisible cool mist will be produced immediately.

## REPLACING THE WICK

The wick will need to be replaced periodically. The frequency will be determined by factors such as the amount of impurities and hardness of your water. **We recommend visually inspecting the wick once a week.** The wick will need to be replaced if it appears to be filled or covered with mineral deposits or other impurities.

Make sure the humidifier is turned OFF and unplugged. Remove the tank and the mist chamber. Remove the old wick straight up from the tray. Rinse and insert a new OPTIMUS wick into the tray. Be sure the wick is properly seated.

The wick is a vital component of the humidifier. **Do not use the humidifier without a wick. Do not alter or attempt to repair a wick. The wick is not washable or reusable.** Replace it with OPTIMUS model # U-30012 wicks only. Using any other wicks may cause damage to the humidifier, create a safety hazard, and void the warranty. Replacement wicks may be purchased from the store where you purchased the humidifier. Alternatively, you may email us at [Service.Optimus@gmail.com](mailto:Service.Optimus@gmail.com) or call us at 1-888-672-5832 to order. Always give the model number and part description when order.

## CLEANING THE HUMIDIFIER

It is strongly recommended to clean the humidifier at least once a week or sooner if you:

- Have hard water
- Notice a buildup of impurities
- Notice an unpleasant odor.

Wipe the base and the housing of the humidifier with a damp soft cloth periodically. Do

not use harsh, abrasive cleaners. Never submerge the mist chamber in liquid or pour liquid in or on it. Doing so may damage the unit and may cause injuries.

**Always turn off and unplug the humidifier before cleaning.**

## CLEANING THE TANK

Put 1/2 teaspoon of chlorine bleach and 1/2 gallon of water in the tank. Let solution stand for 20 minutes, swishing every few minutes. Empty tank(s) and rinse well with water until the bleach smell disappears.

## CLEANING THE TRAY

From time to time mineral deposits will accumulate in and on the tray. When this occurs, the tray needs to be cleaned. Remove the tank, mist chamber, and wick. The tray may be cleaned with a damp, soft cloth or in a dishwasher.

**CAUTION:** Only the tray is dishwasher safe. Do not attempt to put the tank, cap, housing or wick in a dishwasher. Doing so may damage the humidifier and create a safety hazard.

## END OF SEASON CARE AND STORAGE

- Empty all water out of the tank and base.
- Clean all surfaces with a damp soft cloth.
- Clean the base with a dishwasher or wiping it with a damp, soft cloth.
- Replace the old wick with a new one to prevent mold or mildew.
- Store the unit in its original carton and in a cool dry location.
- Remember to clean and inspect your humidifier before using it the next season.

# WARRANTY

For your own records, staple or attach your sales receipt to this manual. Please also write the store name/location and date purchased below.

STORE NAME/LOCATION: \_\_\_\_\_

DATE PURCHASED: \_\_\_\_\_

## ONE (1) YEAR LIMITED WARRANTY:

(SAVE THIS WARRANTY INFORMATION)

Optimus Enterprise, Inc. warrants to its customers and or consumer of this humidifier and the parts thereof will be free from defect in material and workmanship, under normal use, for a period of one (1) year from the date of initial purchase. **The warranty DOES NOT cover the wick, which is an expendable part.** The warranty does not apply to repairs necessitated by damage, misuse, abuse or alternation and to any repair of merchandise not used within the United States. Unless otherwise proscribed by law, Optimus Enterprise, Inc. shall not be liable for any personal injury, property damage or any incidental or consequential damages of any kind (include water damage) resulting from malfunctions, defects, misuse, improper installation or alternation of this product. This warranty is the only warranty extended by Optimus Enterprise, Inc. to its original customers and/or consumer purchased of this unit. Optimus Enterprise, Inc. disclaims all other warranties, express or implied, that arise by the operation of law, specifically including the implied warranties of merchantability and fitness for a particular purpose. Optimus Enterprise, Inc. shall not be liable for any incidental or consequential damage, which may have resulted from any alleged breach of warranty. Some states do not allow limitations on how long implied warranty lasts or the exclusion or limitation of incidental or consequential damage, so the above limitations or exclusion may not apply to you. This warranty gives you specific legal rights you may also have other rights which vary from state to state.

Should the humidifier fail during the warranty period, the owner should:

- After you purchase the product and find parts missing or you have any question, please e-mail or call Optimus Enterprise, Inc. first. **DO NOT RETURN THE UNIT TO THE STORE.**
- Within the first 12 months from date of purchase, Optimus Enterprise, Inc. will repair or replace the product if it is defective in material or workmanship providing it is returned to Optimus Enterprise, Inc. with freight prepaid, with evidence of purchase date (cash register receipt) together with a check or money order for shipping/handling charges.

**IMPORTANT: ANY REPAIRS SHOULD BE PERFORMED BY AN AUTHORIZED SERVICE REPRESENTATIVE. DO NOT ATTEMPT TO REPAIR THIS PRODUCT YOURSELF. DOING SO MAY VOID YOUR WARRANTY. PLEASE RETAIN THIS WARRANTY AND SALES RECEIPT TO ENSURE YOUR PRODUCT WARRANTY.**

## IMPORTANT: RETURN INSTRUCTIONS:

Your warranty depends on your following these instructions if you are returning the unit within the warranty period.

- Carefully pack the product in the original container or a suitable one to avoid damage in shipping.
- Seal the carton. Send the package freight prepaid to the following address:  
Optimus Enterprise, Inc.  
Customer Service Department  
2201 E. Winston Road, Unit #J  
Anaheim, CA92806  
1-888-672-5832
- Inside an envelope, enclose
  - 1) Your name, full address with zip code, daytime phone number
  - 2) A brief explanation of the problem you are having with the unit
  - 3) Evidence of purchase date such as a cash register receipt, and
  - 4) A CHECK OR MONEY ORDER of **\$18.00** for return shipping / handling.
- Optimus Enterprise, Inc. recommends you insure the package as damage in shipments is not covered by your warranty.
- All shipping charges must be prepaid by you (as noted above).

## SERVICE INSTRUCTIONS:

- Do not attempt to repair or adjust any electrical or mechanical functions of this unit. Doing so may void the warranty.
- If you have any questions regarding this unit's operation or believe any repair is necessary, lease e-mail us at [Service.Optimus@gmail.com](mailto:Service.Optimus@gmail.com) or call us at 1-888-672-5832 to speak with a Customer Service Representative.
- If an exchange is determined necessary, please return it, in its original carton, along with the sales receipt, to the store where you purchased it. If you are returning the unit more than 30 days from the date of purchase, please see the enclosed warranty.