



## Automatic Inflator Head Unit Instruction Manual

---



---

### WARNING:

Read carefully and understand all INSTRUCTIONS before operating. Failure to follow the safety rules and other basic safety precautions may result in serious personal injury. Save these instructions in a safe place and on hand so that they can be read when required. Keep these instructions to assist in future servicing.

---



**WARNING:** Thank you for selection our Digital Tire Inflator, please read this manual before carrying out any installation or service procedure. Please keep it away from damp, heat, dust, oils, do not remove, tear or amend any parts of the manual for any reason. It must be made available to the operator and to maintenance personnel, also to ensure staff training. The manufacturer reserves the right to change product features at any time.

**The manufacturer reserves the right to change product features at any time.**

Through the manual the following symbols will be used, this information is for your safety and to prevent damage to this product.



**CAUTION**

The hazard or unsafe practice could result in minor injury



**WARNING**

The hazard or unsafe practice could result in severe injury or death

# Control Panel

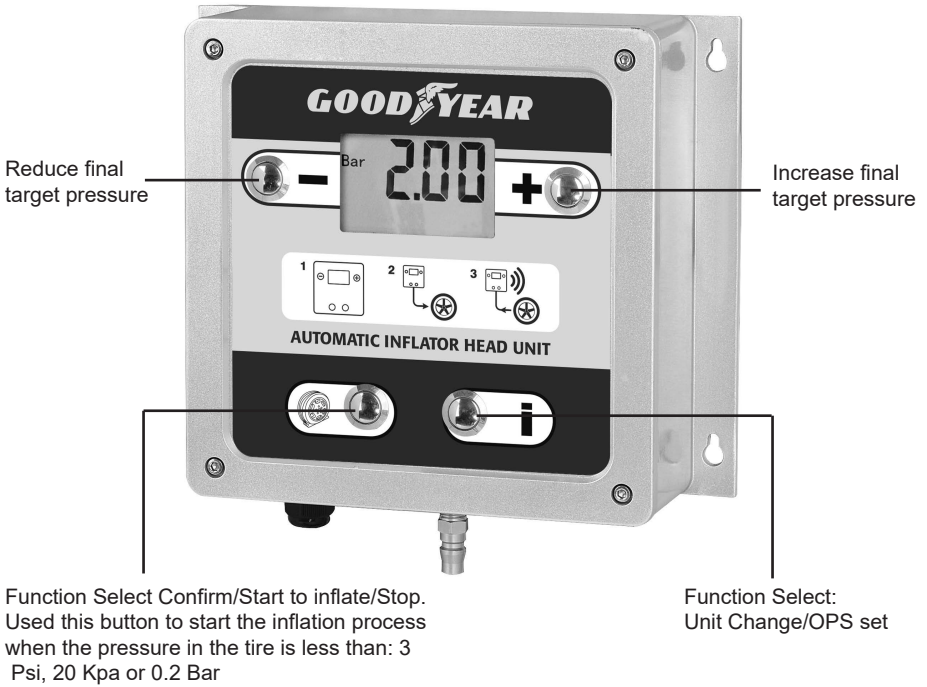

## Installation

### Notes in advance:

1. Any Mechanical Devices used to lift or transport the inflator must be operated by professional people.
2. During inactivity period, please package the inflator and keep it away from damp, heat, impact, etc.
3. After unpacking the inflator, the packing materials should be disposed of according to the laws and regulations applicable at the place being used.
4. Please check carefully to ensure that no part is damaged, so to ensure safety and formal operation.
5. It can be installed outside, but a shelter is suggested, so to protect the equipment from bad weather, extend the service life.



### WARNING:

Installation of the inflator should be done by qualified people.



### WARNING:

Ensure that the product is connected to the correct power and air supply, refer to rating label and general specifications.

1. Hold the unit up on the wall and mark where the four (4) holes are to be drilled.
2. Secure the unit using suitable fastener.
3. Connect the air supply to the unit.
4. Connect the rubber hose to the air outlet.
5. Connect the power supply.

## Remark

1. Since directly compressed air contains oil and water, water is from condensation and oil is from the compressor, water and oil will strongly destroy the device, so it is important to filter them out first from the system.
2. Keep the compressed air inlet pressure within 150psi (1050kpa/10.5bar/10.5kg/cm<sup>2</sup>).
3. Electrical connection should be carried out by a qualified electrician.
4. Protection switch is not supplied with the device; please install the protection switch on your own if necessary.



### WARNING:

To avoid equipment damage, never exceed the manufactures maximum inlet pressure of 10.5bar, 1050kpa, 150psi, 10.5kg/cm<sup>2</sup>

## Function and Operation

The device is including the OPS (over pressure setting) function.

### 1. Unit select

Device has four units can be chosen by the user which is kpa-psi-bar-kg/cm<sup>2</sup>. Unit set here will become the default setting, you do not need to change the setting each time you turn it on.

- ① Press **【i】** , **【SET】** will be shown on the LCD screen, and the unit will be flashing.
- ② Press **【+】** or **【-】** to choose the unit.
- ③ Press **【⊙】** to confirm.

## 2. Set OPS

- ① Press **【i】** twice, **【SET】** and **【OPS】** will be shown on the LCD screen, **【OPS】** will be flashing.
- ② Press **【+】** or **【-】** to choose the OPS value.
- ③ Press **【⊙】** to confirm. If OPS value is not zero, **【OPS】** will be displayed at the LCD screen.

## 3. Inflation and Deflation

- ① Press **【+】** or **【-】** to select target pressure.
- ② Connect with tire, ensure no air leaks, inflator will work automatically.
- ③ When inflation is finished, machine will stop automatically and BEEP to remind users.
- ④ Disconnect the air hose from tire, finish inflation.

## Remark

1. Press **【i】** to enter the function setting mode. After select the unit, press **【i】** again to enter the **【OPS】** setting directly, press **【i】** thrice the device will quit out of the setting mode without save any selection .
2. When OPS function is on, device will inflate to target pressure plus OPS value first, then deflate to tire pressure desired, for example: A final target of 32 psi or 2.2 bar with an OPS setting of 16 psi or 1.1 bar gives a sum of 48 psi or 3.3 bar. This sum of 48 psi or 3.3 bar is the Over Pressure setting for tire. The tire will inflate to the sum value and deflate to the final target pressure.
3. If tire pressure is lower than 3 psi or 0.2 bar, device will not start automatically. Then press **【⊙】** for 2 second to start manually.
4. During inflation, device will check tire pressure automatically, rolling bar will be on, and left to right means inflating, right to left means deflating.



### **WARNING:**

To avoid the risk of personal injury, especially to his eyes, face or skin. DO NOT direct the air steam at any person.



### **WARNING:**

This equipment is not intended for use by children without adult supervision.



### **WARNING:**

When using the OPS function, the sum pressure must not exceed the tire manufacture's maximum inflation pressure.

# Troubleshooting

PROBLEM	POSSIBLE CAUSE	SOLUTION
Air leak	Leak in the connection	Check the pneumatic Connection
The inflator works, But no air inflated	Obstruction in filters or in air system	Clean the filters and check the air tube
No display	Check power supply	Reconnect
Inflation does not start, although the pressure is set and the hose is connected with tire	Air hose improperly connected	Check the hose connection, make sure that no air leaks
	Tire pressure is below 0.2bar (3psi)	Press 
The unit deflates very slowly	The silencer plug on is blocked	Remove and clean the silencer plug
Err1	Pressure sensor broken	Power off, change pressure sensor
Err2	Unstable pressure, faulty hose connector	Replace hose connector or re-connect hose to the tire
Err3	Connected Tire pressure is too high pressure > 13bar (188.5psi)	Stop inflating this tire
Err4	Wrong connections at air inlet and outlet	Refer to wiring diagram and connect magnetic valve accordingly
Err5	Low Voltage	Check the power supply
Err6	Calibration Error	Unit requires calibration
Err7	Calibration Error	Unit requires calibration
Err8	Air supply lower than set inflate pressure	Stop inflating this tire

# Wiring Diagram

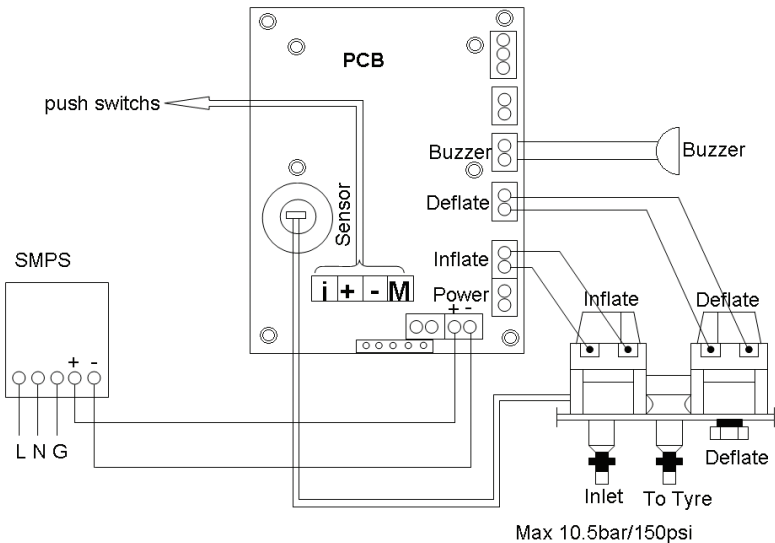

# Maintenance

## 1. Daily Maintenance

The device does not require maintenance, routine check of the pneumatic connection is suggested. Daily maintenance should be carried out by qualified personnel.

## 2. Special Maintenance

All the maintenance not included in Daily maintenance are special maintenance, which should be done by qualified personnel. Authorized agent could be contacted for it.

## 3. Warranty

This model wall-mounted tire inflator is warranted for 1 year, except if the products has been damaged by misuse, faulty installation, incorrect maintenance or accidental damage, unauthorized modification or repair, force majeure. Warranty does not cover air hoses, hose connectors (hose chucks).

### Note:

All faulty PCBs that are within the warranty period are to be returned to factory for assessment and repairs. PCBs with are found to be burnt due to water damage will not be covered under any warranty.

## General Specification

110V~240V 50Hz-60Hz 10WMAX 800mAMAX	
Max Air Inlet:	150psi (10.5bar)
Max Air Outlet:	145psi (10bar)
Ambient Temp:	14°F-122°F (-10°C-50°C)
Precision:	±0.3psi (0.02bar)



Goodyear (and Winged Foot Design) are trademarks of or licensed to  
The Goodyear Tire & Rubber Company used under license by  
Intradin (Shanghai) Machinery Co, Ltd.  
118 Duhui Road, Minhang, Shanghai, China.  
© 2025 The Goodyear Tire & Rubber Company