

OWNER'S MANUAL

Model: UTV-45-7-PRO (5303073)

(45 Gallon Lawn & Garden UTV Sprayer w/7-Nozzle Boom)

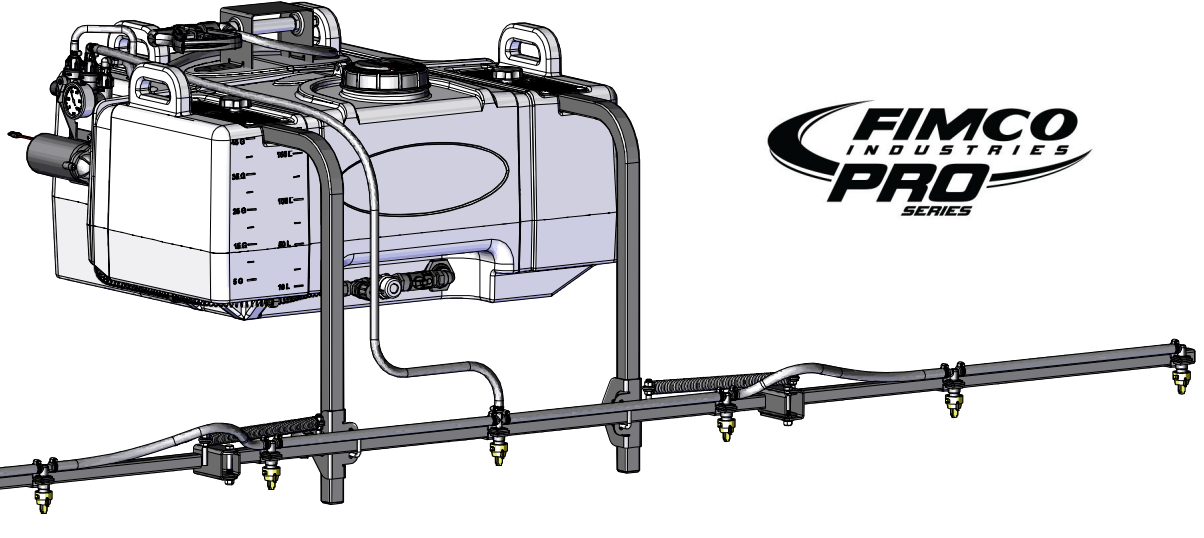

Professional Grade Pump (4.0 GPM):
Ideal for Harsh Chemicals & Oil
Based Chemicals with Surfactants

Long Range 13" PRO SERIES Handgun
38' Horizontal Spray & 27' Vertical

Roundup® Ready

General Information

Thank you for purchasing this product. The purpose of this manual is to assist you in operating and maintaining your UTV sprayer.

**BEFORE RETURNING THIS PRODUCT
FOR ANY REASON, PLEASE CALL**

1-800-831-0027

MONDAY-FRIDAY, 8:00 AM TO 5:00 PM CST

If you should have a question or experience a problem with your Fimco Industries Product: Visit our website @ www.fimcoindustries.com or call the Toll free number above. Our technical support representatives will be happy to help you. In most cases a customer service rep. can resolve the problem over the phone.

To obtain prompt, efficient service, always remember to give the following information....

- Correct Part Description and/or part number
- Model number and Serial Number

Part descriptions and numbers can be obtained from the illustrated parts list section(s) of this manual.



WARNING: Cancer and Reproductive Harm.
www.P65Warnings.ca.gov



WARNING: To reduce the risk of injury, the user must read and understand the operator's manual before using this product.

IMPORTANT REMINDER

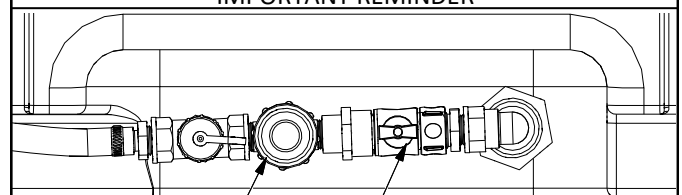

This sprayer comes with an On/Off valve located on your intake line. Make sure the valve is in the "open" position before using this sprayer.



www.fimcoindustries.com

1000 FIMCO Lane, P.O. Box 1700, North Sioux City, SD 57049
Toll Free Phone: 800-831-0027 : Toll Free Fax: 800-494-0440

[5195269

(10/22)]

Retain a copy of your receipt for your unit, as it will be required to validate any warranty service.

Warranted against manufacturer or workmanship defects from date of purchase with copy of receipt:

Homeowner Usage: One Year.

Commercial Usage: 90 Days.

Contents

Technical Specs	2	Sprayer Parts List.....	8
Sprayer Assembly Instructions	3	Sprayer Exploded Views.....	9 - 10
Operation	4	ProSeries Handgun Info	10
Calibration and Maintenance	5	Boom Exploded View/Parts List	11
Tank Care and Winter Storage	6	Multi-Lid Info.....	12
Pump Exploded View and Parts List	6	Sprayer Dimensions	12
Troubleshooting	6 - 8	Warranty	14

Model: UTV-45-7-PRO (5303073)

(45 Gallon Lawn & Garden UTV Sprayer
w/7-Nozzle Boom)

Technical Specifications

- 45 Gal. Corrosion-Resistant Polyethylene Tank
- 13" Pro Series Handgun w/25 Ft. Handgun Hose
- 7-Nozzle Boom Assembly (140" Spray Coverage)
- Drift Reducing Corrosion-Resistant Nozzles w/"No-Drip" Check Valve Strainers
- Adjustable Boom Height
- Pro Series 4.0 GPM, 45 PSI, 12 Volt Pump
- Multi-Lid to accurately measure and pour chemicals

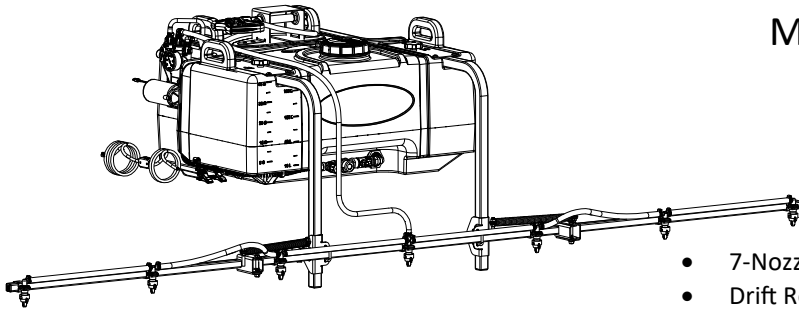

CAUTION: When fully filled with water, this sprayer will weigh approx. 470 Lbs.

Always check the vehicle load rating before using this sprayer. Do not exceed the recommended rating.

~~~~~IMPORTANT~~~~~

Remove tank lid and be sure the tank is clean and free of any foreign material. Rinse tank out of any tank residue before filling with water to test.

~~~~~IMPORTANT~~~~~

It is VERY important to test this sprayer with plain water before actual spraying is attempted. This will enable you to familiarize yourself with the sprayer and check for leaks without the possibility of losing any expensive chemicals.

~~~~~WARNING~~~~~



Read and Understand the Owner's Manual before using this sprayer. Test and use in accordance to instructions.

Read and Follow chemical label instructions and wear protective gear when filling, using, cleaning and servicing the sprayer.

Exercise Caution in vehicle handling when towing/hauling a filled sprayer to avoid loss of control or overturning.

Keep Sprayer and Spray materials away from other people, children and pets.

Do Not Turn on Power to the sprayer, until ready to spray in order to avoid unintentional spray release.

Do Not Use on steep slopes. A full sprayer could cause loss of control or overturn sprayer and vehicle.

Always operate up and down a slope, never across the face of a slope.

Keep all movement on slopes slow and gradual. Do not make sudden changes in speed, directions or turning. Do not start or stop suddenly when going uphill or downhill.

Stop on level ground, set the parking brake and shut off engine before leaving the operator's position for any reason.

Keep all parts in good condition and properly installed. Fix damaged or worn parts immediately.

Caution should be taken when towing and/or using any sprayer. This sprayer combined with the weight distribution, turning radius and speed of vehicle can result in damage to vehicle and/or sprayer or severe injury or death, if not used properly.

Improper use of this sprayer or handling of chemicals could result in serious injury or illness, or could cause damage to the environment.

Assembly Instructions:

- The sprayer is partially assembled.
- Follow the steps on page 3 to properly complete assembly of the sprayer.

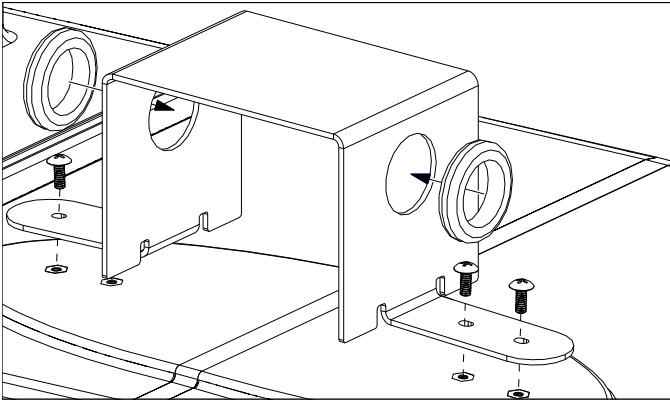

Attach hose bracket to the top of the tank with (4) PH screws and insert the (2) grommets into the bracket.

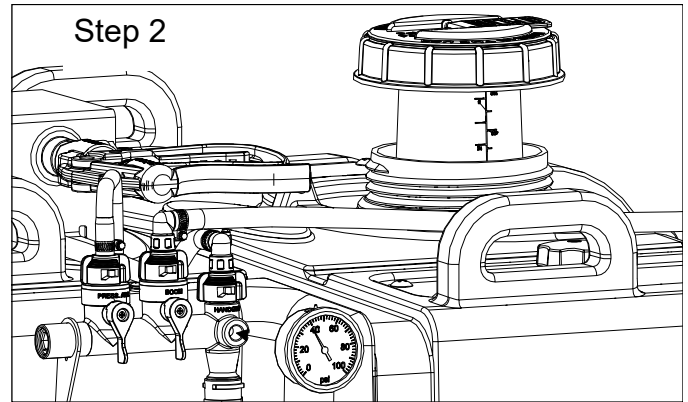

Thread pressure gauge into open port on manifold, as shown.
Thread Multi-Lid on to the tank.

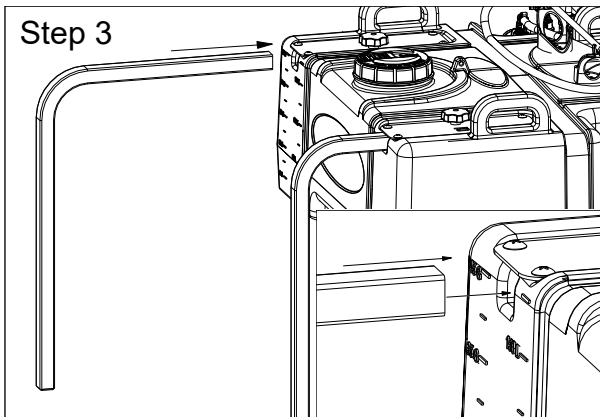

With the unit in a UTV Box, slide the boom mount tubes in to the tank mounts and tighten the lobe knob.

* Secure tank using tie-down straps (NOT INCLUDED)

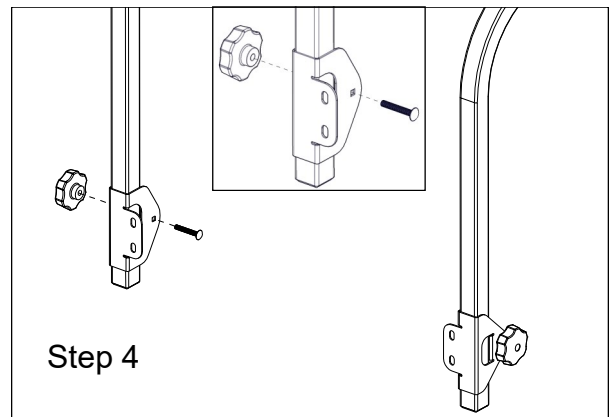

Slide boom clamps up boom mount tubes, install the 1/4" carriage bolt and Lobe Knob, make sure boom clamps are installed with the square carriage bolt holes or two boom mount holes to the inside, with lobe knob to the outside.

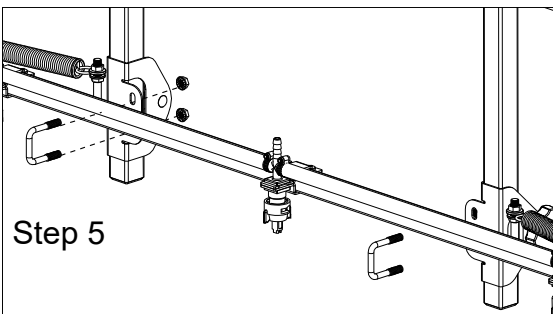

Using the square U-bolts and nuts, attach the boom to the boom clamps. With boom secured to the boom clamps, the nozzle harness can now be attached. Center nozzle harness to the boom and using the nozzle clamps, loosely attach nozzle harness to the boom. Once all nozzles are attached and the harness is centered, tighten clamps to the boom. Finally attach boom hose. Slip (2) 3/8" hose clamps onto hose. Attach, with a twisting motion, one end of hose to the boom and the other end to the manifold. The boom hose can be cut to length if needed.

Once fully assembled, to remove the sprayer from a UTV Box, disconnect the boom supply hose from the manifold, using the quick connect fitting. Then loosen the two lobe knobs on the tank mounts and slide the boom out and set aside. Then the tank can be removed and set on the ground without damaging the tank or boom. The handles can be used to lift the empty tank in and out of the box. Tie down straps can be installed through the handles to secure the tank.

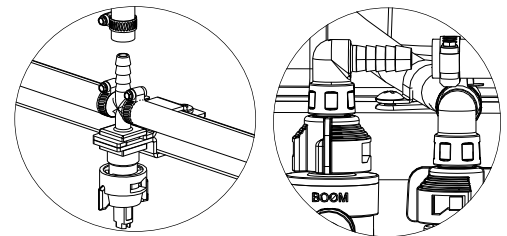

- Make sure all hose clamps are tight before testing or spraying for the first time.
- One requirement will be to hook up your battery leads to a fully charged 12 Volt battery.

****The Sprayer is now ready to TEST w/plain water before actual use****

IMPORTANT: Remove tank lid and be sure the tank is clean and free of any foreign material. Rinse tank out of any tank residue before filling with water to test.

Testing the Sprayer

NOTE:

It is VERY important to test this sprayer with plain water before actual spraying is attempted. This will enable you to check the sprayer for leaks without the possibility of losing any expensive chemicals.

Fill the tank about 1/2 full with plain water and drive to the starting place for spraying.

When you are ready to spray, turn the boom valve to the “on” position (Detail A). This will start solution spraying from the tips of the boom. The pressure will decrease slightly when the boom is spraying.

Adjust the pressure by turning the “ON/OFF” valve lever on the Press. Adj. (bypass) valve (Detail B). Make sure your pattern is sufficient. You may down-pressure the system by ‘bypassing’ solution back into the tank. This is achieved by opening the Press. Adj. (bypass) valve. Regulating pressure is done in this manner.

Read the operating instructions and initially begin spraying by closing the ‘Pressure Adjust’ valve and opening the boom line valve (Detail A). This will enable the air in the line to be eliminated (purged) through all the tips, while building pressure. When everything tests all right (no leaks and good pressure), add the desired chemicals to the mixture and water combination and start your spraying operation. Adjust the pressure and spray as you did in the testing procedure.

Conditions of weather and terrain must be considered when setting the sprayer. Do not spray on windy days. Protective clothing must be worn in some cases.

Be sure to read the chemical label(s) before application!

Operation

The pumping system draws solution from the tank, through the strainer and to the pump. The pump forces the solution under pressure to the handgun or boom nozzles.

Fill the tank part way with water and then add the desired amount of chemical to be sprayed. Finish filling tank to proper level.

Only fill the tank with what you’re going to spray in a day, never leave chemicals sit in tank.

Connect the lead wire to a fully charged 12 volt battery. You may use either a stand-alone battery or the battery on your towing vehicle.

Connect to the positive (red) terminal first, then connect to the negative (black) terminal. Then connect the end of the lead wire to the end of the pump. When disconnecting, disconnect the end of the pump wire from the lead wire, then disconnect the negative (black) connection and finally the positive (red) connection. The lead wire has an On/Off switch to activate the pump.

“-” is on and “O” is off.

Turn the pump on by depressing the “-” side of the rocker switch. The pump is equipped with a pressure switch that is pre-set at the factory to shut the pump off when all discharges are closed.

The pump will turn back on when one of the following actions occurs:

- ◆ Handgun lever is squeezed to spray the handgun.
- ◆ Boom valve is opened to broadcast spray with the boom.
- ◆ Bypass valve is opened to re-circulate solution back into the tank.

When spraying with either the boom or the handgun, pressure may be reduced by slowly opening the Press. Adj. (bypass) valve until desired pressure is achieved. Opening the valve decreases pressure, closing the valve increases pressure. When spraying with the boom, the proper method to set the pressure is to open the boom valve completely and if a lower pressure is desired, then slowly open the Press. Adj. (bypass) valve until that pressure is obtained.

For the safest and most efficient chemical application, you will need to calibrate your sprayer using the tip and speed charts. Once you have determined the proper speed and pressure settings, you will need to consult your chemical label for the amount of chemical to be added to the tank. Read the entire label. Use only according to label directions.

Manifold Valves CLOSED

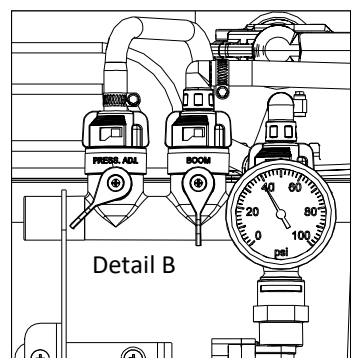
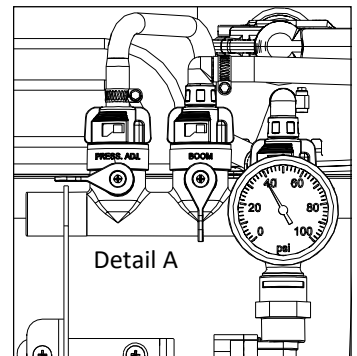
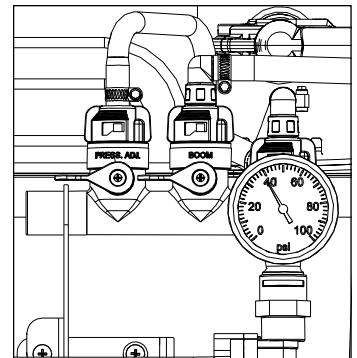

Calibration

Chemical labels may show application rates in gallons per acre, gallons per 1000 square feet or gallons per 100 square feet. You will note that the tip chart shows 2 of these rating systems. Once you know how much you are going to spray, then determine (from the tip chart) the spraying pressure (PSI), and the spraying speed (MPH).

Determining the proper speed of the pulling vehicle can be done by marking off 100, 200 & 300 feet. The speed chart indicates the number of seconds it takes to travel the distances. Set the throttle and with a running start, travel the distances. Adjust the throttle until you travel the distances in the number of seconds indicated by the speed chart. Once you have reached the throttle setting needed, mark the throttle location so you can stop and go again, returning to the same speed.

Add water and proper amount of chemical to the tank and drive to the starting place for spraying.

	Pressure (psi)	Capacity (GPM)	1 MPH	2 MPH	3 MPH	4 MPH	5 MPH	6 MPH	8 MPH	10 MPH
Gallons Per Acre Based on Water	15	.12	35.6	17.8	11.8	8.9	7.1	5.9	4.5	3.6
	20	.14	41.6	20.8	13.8	10.4	8.3	6.9	5.2	4.2
	30	.17	50.4	25.2	16.8	12.6	10.1	8.4	6.3	5.0
	40	.20	59.6	29.8	19.8	14.9	11.9	9.9	7.4	5.9
Gallons Per 1000 Sq. Ft. Based on Water	15	.12		.41	.27	.20	.16			
	20	.14		.48	.32	.24	.19			
	30	.17		.58	.39	.29	.23			
	40	.20		.68	.45	.34	.27			

Speed in M.P.H. (Miles Per Hour)	Time Required in seconds to travel a distance of		
	100 Ft.	200 Ft.	300 Ft.
1.0	68 sec.	136	205
2.0	34	68	102
3.0	23	45	68
4.0	17	34	51
5.0	14	27	41
6.0	11	23	34
7.0	9.7	19	29
8.0	8.5	17	26
9.0	7.6	15	23
10.0	6.8	14	20

Using the Boom Nozzles

Four things must be considered before spraying with the boom.

1. How much chemical must be mixed in the tank.
 2. Rate of spray (gallons per acre to be sprayed).
 3. What pressure (p.s.i.) will be used.
 4. Speed traveled (mph) while spraying.
- * Refer to the chemical label to determine your chemical mixture
 - * See the tip chart to determine the pressure to be used. The chart will also show the speed used when spraying.
 - * Start the pump and open the valve to the boom nozzles.
 - * Check the spray pattern. Usually you can see the coverage better on a solid concrete surface, such as a driveway.

Maintenance During/After Spraying

Periodically check the strainer and clean the screen on your intake line.

If sprayer becomes clogged during use, discontinue use immediately. DO NOT attempt to service while chemicals are in the sprayer and power is connected.

Proper care and maintenance will prolong the life of your sprayer.

After use, drain the tank and store or dispose of chemical properly. Fill the sprayer half way with clean water. Start the pump and allow the water to pump through the entire plumbing system and nozzles. Drain and then refill half full, add the recommended amount of a good quality tank cleaner, such as FIMCO Tank Neutralizer and Cleaner. (If no tank cleaner is available, you may substitute dish soap for this step, about 1-2 oz. per gallon). But a neutralizer/cleaner should be used to thoroughly clean the system. Turn pump on and circulate through system for 15 minutes and then spray out through boom and handgun nozzles. Refill sprayer half way with clean water and repeat. Follow the chemical manufacturer's disposal instructions of all wash or rinsing water. If boom or handgun nozzles need cleaning, remove them from the sprayer and soak in warm soapy water. Clean with a soft bristled brush or toothpick if necessary. Never use a metal object. Even the slightest damage can change the flow rate and spray distribution. Water rinse and dry the tips before storing.

WARNING: Some chemicals will damage the pump valves if allowed to soak untreated for a length of time! ALWAYS flush the pump as instructed after each use. DO NOT allow chemicals to sit in the pump for extended times of idleness. Follow the chemical manufacturer's instructions on disposal of all waste water from the sprayer.

Tank Care & Maintenance

Warning: Do not use the tank as a container for fuel oils, kerosene, gasoline or any other petroleum distillate product. All polyolefins are softened and permeated by such products. In an enclosed area the vaporization of these materials from the outside surface of the tank could create a dangerous condition.

The tank should not be used as a pressure vessel nor used with chemicals or solutions having a weight of more than 12 pounds per gallon.

Store the tank in a dry dark place when not in use. Storage out of sunlight will prolong the life of the tank.

Do not drop, strike or kick the tank, especially at low temperatures. Tanks become brittle and are subject to cracking at temperatures below 20° Fahrenheit.

Always flush the tank with water and a neutralizing agent at the end of each use, to prevent contamination of solutions.

Winter Storage

Prepare the sprayer for end-of-season storage by running RV antifreeze through the system. This will keep internal parts lubricated, protect against corrosion and keep the unit from freezing. *Note: RV antifreeze is non-toxic and biodegradable and generally safer for the environment than automotive antifreeze.*

Before storing your sprayer for winter or long term storage, thoroughly clean and drain it as much as possible. Then pour enough pink RV antifreeze into the tank so that when the pump is turned on you can pump the antifreeze throughout the entire plumbing system, including the bypass. Make sure to operate the boom and handgun until you see pink fluid spraying from the nozzles. Leave any remaining antifreeze in the tank. Before your next usage, rinse the antifreeze from the sprayer with clean water.

It is nearly impossible to drain all of the water from the sprayer and any trapped water can freeze in cold weather and damage parts of the sprayer. Pumping the antifreeze through the system will displace the water and help prevent this damage.

Removing from storage: drain the antifreeze. Fill the tank with fresh water and run through the system. Dispose of antifreeze and flush water properly.



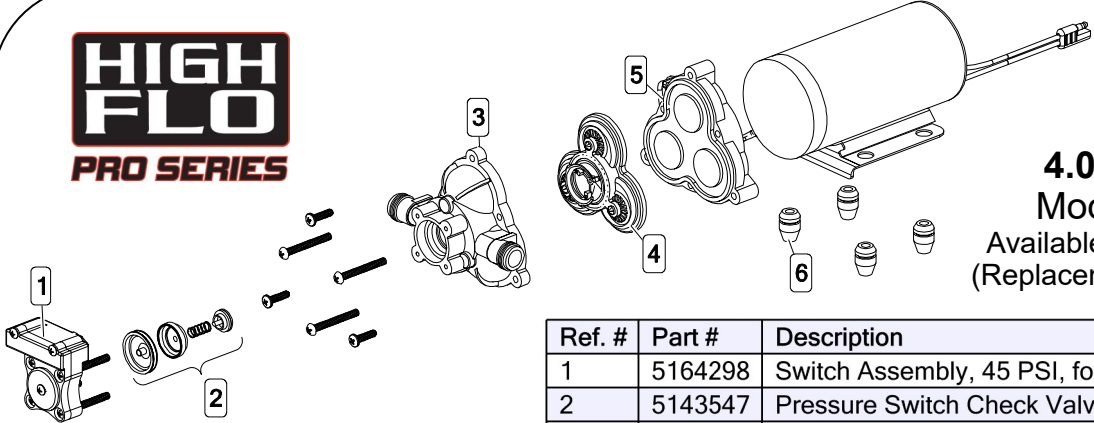

4.0 GPM Pump
Model: 5151073
 Available Replacement Parts
 (Replacement Pump: 5281326)

Ref. #	Part #	Description	Qty
1	5164298	Switch Assembly, 45 PSI, for 2088 Series	1
2	5143547	Pressure Switch Check Valve Kit, 2088	1
3	5151057	Upper Housing, 2088 Series, 1/2" MSPT	1
4	5143548	Valve Kit, 2088 Series	1
5	5281598	4.0 Pro Drive Assembly, Geolast Diaphragm	1
6	5075029	Pump Mount Grommet	4



- Clean and rinse your pump after each use with Fimco Tank Neutralizer.
- Winterize your pump or sprayer by rinsing, draining and running RV Antifreeze through it before storing for the winter.
- Use clean water for your spray mixture.
- Store inside a building when not in use.



- Use to pump bleach.
- Use to pump petroleum products such as diesel fuel, gasoline or kerosene.
- Leave pump sit with spray mixture in it for extended periods.
- Use dirty or unfiltered water for spraying.

STOP **WARNING** **STOP**

DO NOT USE PUMP IN AN EXPLOSIVE ENVIRONMENT.
 DO NOT USE TO PUMP FLAMMABLE/COMBUSTIBLE
 FLUIDS, GASOLINE, KEROSENE, FUEL, OIL, ETC.

CAUTION

PRESSURE SWITCH OPERATION
 Pressure switch is pre-set at the factory. Improper adjustment of the pressure, may cause severe overload or premature failure. If pump is subjected to rapid cycling during normal operations or infrequent periods, damage may occur.

Troubleshooting

Pump will not run:	Check for loose wiring	Pump surges:	Low flow may cause pump to surge
	Make sure the ON/OFF switch is on		Spray Wand is adjusted to small or fine of a spray pattern
	Check the fuse		Check for defective pressure switch
	Check for defective pressure switch		Check for leaks in the discharge line
	Check to see if connected to good 12 Volt Power Source		Check for debris in nozzle orifice
	Check for Low Voltage		Discharge hose may be too long
Pump Does Not Prime (No Discharge w/Motor Running)	Check for clogged strainer/filter	Pump continues to run:	Check for clogged strainer/filter
	Check for kinked inlet/outlet hoses		Check for restriction in discharge line
	Check for empty product supply		Check for empty product supply
	Check for debris in check valve assembly		Check for Low Voltage
	Check for defective check valve		Check for leaks in the discharge line
	Check for cracks in the pump housing		Check for defective pressure switch
Low Pressure/ Low Flow:	Check for air leaks in supply line	Fuse blows:	System has leaks
	Check for a clogged strainer		Air trapped in outlet line or pump head
	Check for proper voltage Try another 12-Volt battery		Check for open bypass valve (if equipped)
	Check for leaks in the discharge line		Check for defective or dirty check valve
	Check for restrictions in the discharge line		Excessive voltage
	Check for debris in intake		Improper adjustment of pressure switch
Check for debris in nozzle orifice	Damaged or defective wiring harness		
			Defective pressure switch

Before Troubleshooting or Attempting to Service the Pump:

- ◆ **Review Troubleshooting Chart:** Do Not attempt to repair until steps below are followed.
- ◆ **Personal Protective Gear:** Wear protective gear when servicing pump.
- ◆ **Disconnect Power:** Disconnect the power to the pump and relieve the pressure from the system.
- ◆ **Empty and Flush** pump system with water, never attempt to service the pump until it has been emptied and flushed.
- ◆ **Perform Repairs:** Follow directions provided in the troubleshooting section to repair the pump.
- ◆ **Test:** Always test the pump for leaks with plain water after any repairs before using.

Sprayer and Pump FAQs:

- ◆ **Why does the pump not run all the time?**
This is an on-demand pump and only runs when a discharge is open (spray gun, bypass, boom (if applicable) or a leak in system).
- ◆ **Why does the pump surge while using the spray gun?**
Low flow/high pressure may cause the pump to surge (or cycle). Typically the spray wand is adjusted at too fine of a mist, to overcome, adjust the nozzle for a higher flow.
- ◆ **How do I adjust the pressure?**
Pressure can only be adjusted by opening the pressure adjust (bypass) valve to allow some of your water or solution to return to the tank (if equipped).
- ◆ **Pump quit and will not run, what do I need to do?**
Squeeze trigger on spray gun to ensure that the system isn't just pressurized up with discharges closed. Check electrical connections, ensure switch is on. Check fuses. Check for proper voltage. Check pressure switch.
- ◆ **Low flow or no flow at all, what do I need to check for?**
Check for a clogged intake hose and/or intake strainer. Check for proper voltage. You will need to occasionally check your intake strainer to ensure that it is clean of any debris.
- ◆ **What is causing the fuse to blow each time I turn the pump on?**
Check for excessive voltage. Improper adjustment of the pressure switch. Damaged or defective wire harness or defective pressure switch.

Warning:

Ensure the wiring harness does not become pinched or damaged in any way. This may damage the pump or cause the wiring harness to overheat, resulting in a melt down or fire.

Troubleshooting Leaking Elbow on Manifold:

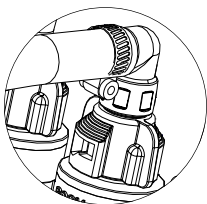

Manifold is leaking at the elbow connection, remove the elbow from the manifold. Quarter turn counter clockwise and lift off. Look inside the cap and make sure the flat washer is in place. If washer is in place, you'll notice a hexagon shaped hole. While holding the elbow and cap at the same time, using an allen wrench or the head of a bolt, something just big enough to catch the edges, give it a twist clockwise to snug up the connection. Elbow is a two-piece interlocking mechanism and may just be a little loose. Replace on manifold.

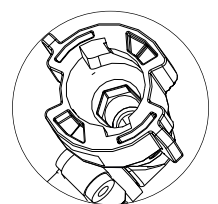

There is a shut-off valve on the intake line. It is at this location so you can shut off the flow of solution to access your system's filter screen for cleaning.

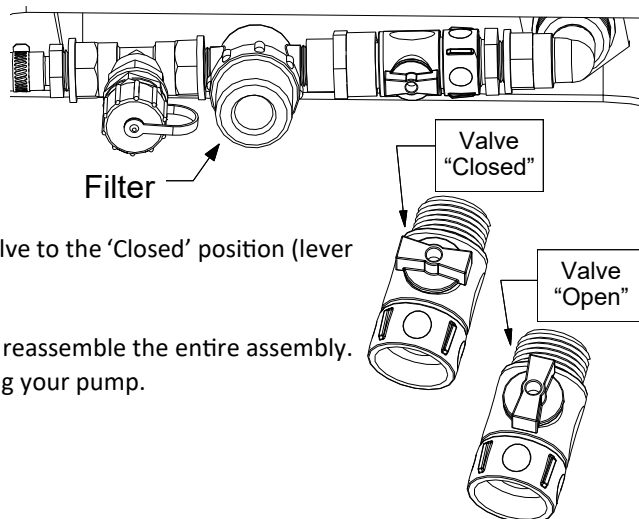

Checking/Cleaning the sprayer's filter/screen:

- ◆ Start your pump and before it shuts off, reach down and shut the valve to the 'Closed' position (lever is perpendicular to the flow of fluid), then shut off your pump.
- ◆ Unscrew the bowl of the filter to access the screen.
- ◆ Remove the screen and clean as necessary. Replace when done and reassemble the entire assembly.
- ◆ Make sure the valve is turned to the 'Open' position before restarting your pump.

Parts List: UTV-45-7-PRO (5303073)

Ref. #	Part #	Description	Qty
1	5169329	45 Gallon UTV Tank w/Bulkhead	1
1.1	TF50DTN	Polypro 1/2" FEM Bulkhead Fitting	1
2	5010205	Poly Elbow, 1/2" MNPT x 3/4" HB	1
3	5010243	Street Elbow, (90°) 1/2" MNPT x 1/2" FNPT	1
4	5005195	Poly Adapter, 1/2" MNPT x 3/4" MGHT	1
5	5281049	45G UTV Intake Plumbing Assembly	1
5.1	5278717	UTV Intake Plumbing	1
5.1.1	5143419	Swivel Shut-Off	1
5.1.2	5016066	1" Rubber Washer	1
5.1.3	5005190	Adapter Coupler, 3/4" FGHT x 1/2" FNPT	1
5.1.4	5116417	Poly Inline Strainer 1/2" MNPT	1
5.1.4.1	5046451	Poly Strainer Cap	1
5.1.4.2	5116452	Strainer Screen	1
5.1.4.3	5072533	Strainer O-Ring	1
5.1.4.4	5058205	Clear Strainer Bowl	1
5.1.5	5010230	Poly Tee, 1/2" FNPT	1
5.1.6	5005195	Poly Adapter, 1/2" MNPT x 3/4" MGHT	1
5.1.7	5274373	Drain Plug Cap Assembly	1
5.1.8	5067131	Poly Fitting, 1/2" MNPT x 1/2" HB	1
5.2	5020578	1/2" Polyspring Hose x 31"	1
5.3	5051114	Hose Clamp (1/2")	2
5.4	5002502	Fitting, 1/2" FNPT x 1/2" Swivel HB	1
6	5051152	3/4" Black Nylon Loom Clamp	2
7	5117234	#10-24 x 1/2" PH Round Head Screw	7
8	5281520	Pro Series 4.0 Pump Assembly	1
8.1	5151073	Pro Pump: 4 GPM, 45 PSI, 1/2" MSPT	1
8.2	5117166	#10-24 x 1.25 PH Truss Head Screw	3
8.3	5005456	3/4" Port to 1/2" Female NPT Adapter	1
9	5281540	Quick Connect Manifold Assembly	1
9.1	5302347	Quick Connect Manifold (Main Body)	1
9.1.1	5072514	O-Ring - Pump Port Connection	1
9.2	5143430	Flat Washer - Hose Barb Seal	1
9.3	5143431	QC Manifold - 3/8" Hose Straight Barb	1
9.4	5143429	Quick Connect Quarter Turn Cap	1
9.5	5302802	QC Manifold 3/8 Swivel 90° Elbow	2

Ref. #	Part #	Description	Qty
10	5005457	Port Adapter Clip	1
11	5167108	2 1/2" Liquid Filled 100# Back Mount Gauge	1
12	5037943-BLK	Manifold Support Brace	1
13	5117166	#10-24 x 1.25 PH Truss Head Screw	1
14	5100962	Formed Bypass Tube	1
15	5051144	Hose Clamp (3/8")	5
16	5075018	Grommet (1/2" I.D.)	1
17	5020527	Hose, 3/8"-1 Brd. x 25 Ft.	1
18	5051122	5/8" Black Nylon Loom Cable Clamp	1
19	5163149	13" HP Spray Gun with 3/8" Hose Barb	1
19.1	5163137	High Pressure Aluminum Spray Gun 13"	1
19.2	5067130	Poly Fitting, 1/2" MNPT x 3/8" HB	1
20	5038932-BLK	UTV Pro Hose Bracket	1
21	5075014	Rubber Grommet (Black)	2
22	5058200	32 oz -1000 ml Multi-LID	1
23	5278715	UTV Boom Mount	2
23.1	5088026	5 Lobe Knob 1/4-20UNC	1
23.2	5095394-BLK	Tank Boom Mount	1
23.3	5095393-BLK	Boom Clamp	1
23.4	5034527	1/4-20 x 1.50 Carriage Bolt	1
24	5117342	5/16-18 x 0.50 PH Truss Head Screw	8
25	5278716	UTV Boom Tube Assembly	2
25.1	5095395-BLK	UTV Boom Mount Tube	1
25.2	5046448	Square Cap, Black (1 1/4" Square)	2
26	5051151-BLK	Boom Clamp	2
27	5088026	5 Lobe Knob 1/4-20UNC	2
28	5034807	1/4-20 x 1.75 Carriage Bolt	2
29	5006307	5/16-18 Serrated Flng Hex Nut	4
30	5020127	Hose, 3/8"-1 Brd. x 72"	1
31	5301897	7-Nozzle Boom Assembly	1
32	5034159	5/16-18 x 1.3125 x 1.875 Square U-Bolt	2
33	5277040	Lead Wire (14 ga, w/Switch), 120"	1
33.1	5157238	15 Amp Regular Blade Fuse	1

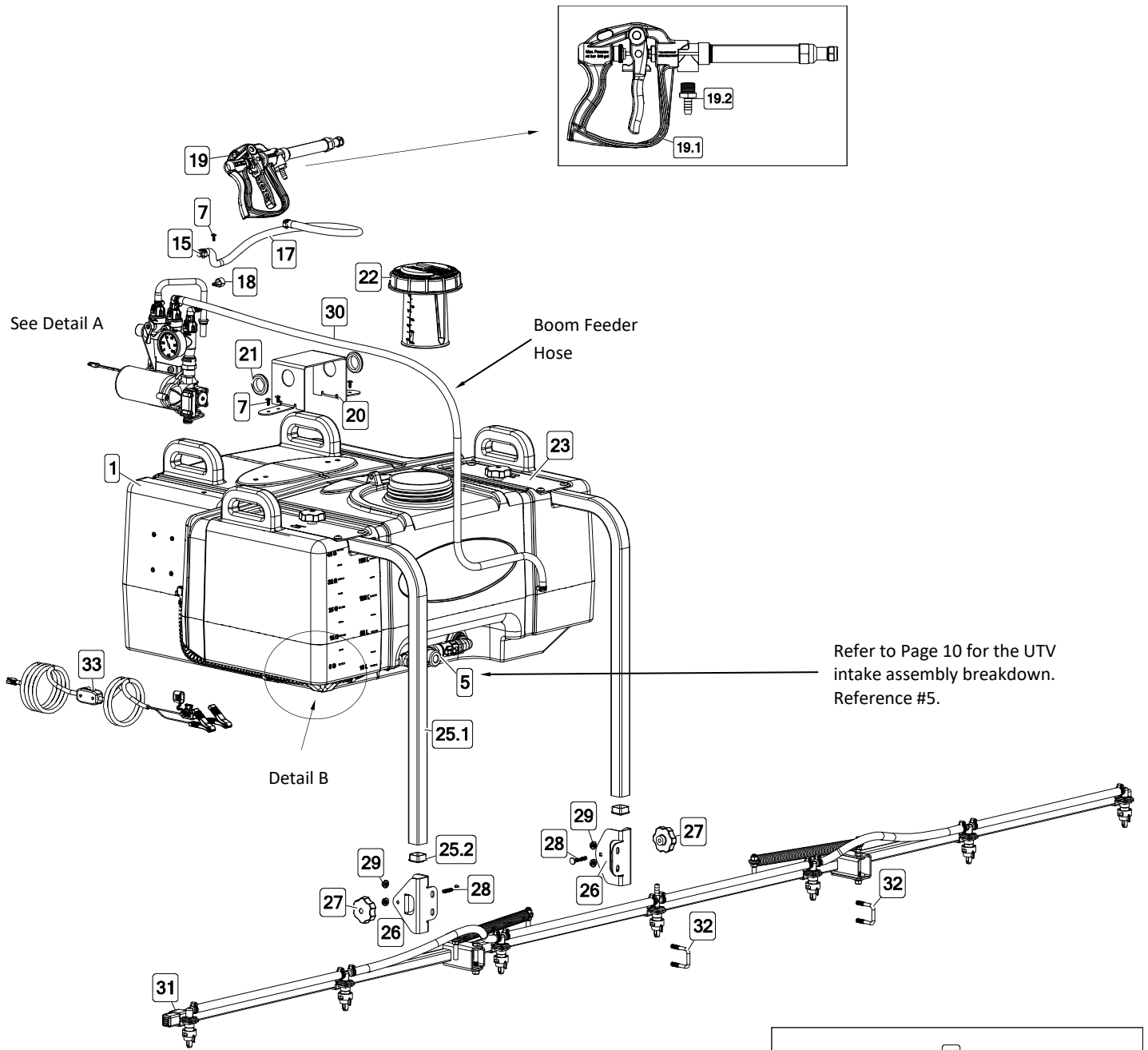

**Exploded View:
UTV-45-7-PRO (5303073)**

Refer to Parts List Previous Page for Part Numbers

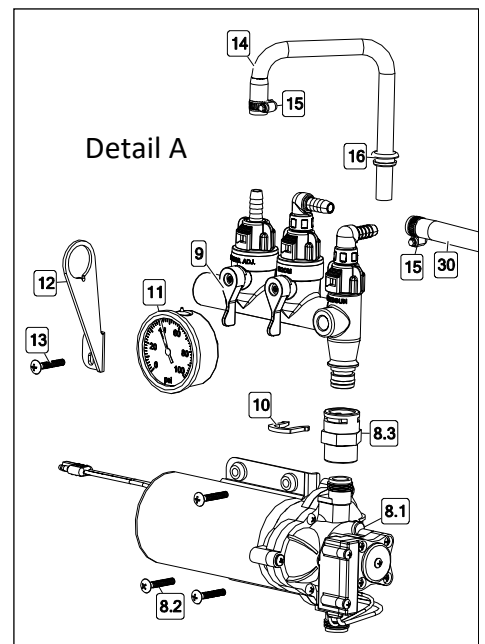
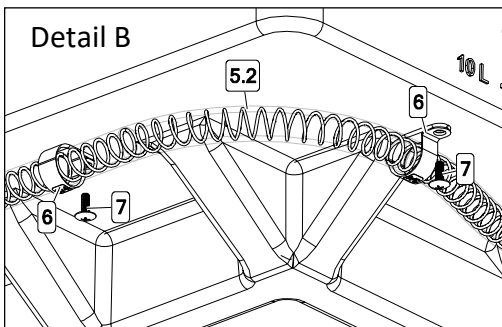

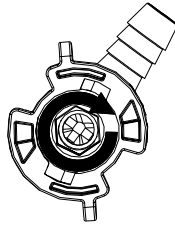
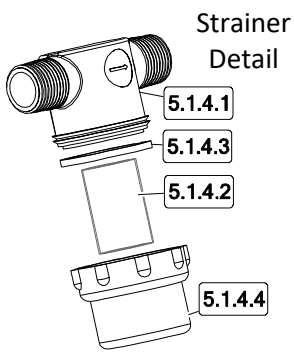
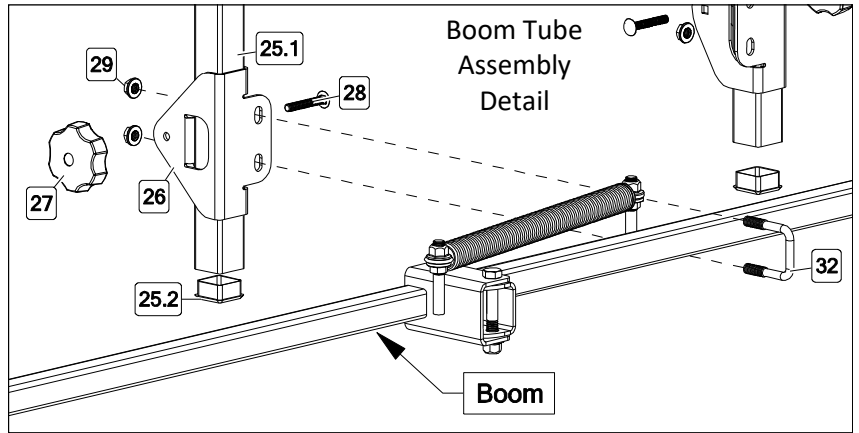
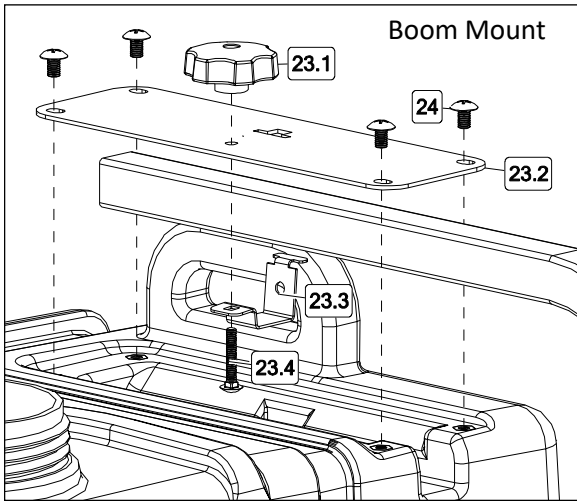

Troubleshooting a leaking quick connect elbow:

Look inside the cap and make sure the flat washer is in place. If washer is in place, you'll notice a hexagon shaped hole. While holding the elbow and cap at the same time, using an allen wrench or the head of a bolt, something just big enough to catch the edges, give it a twist clockwise to snug up the connection. The elbow is a two-piece interlocking mechanism and may just be a little loose. Replace on manifold.

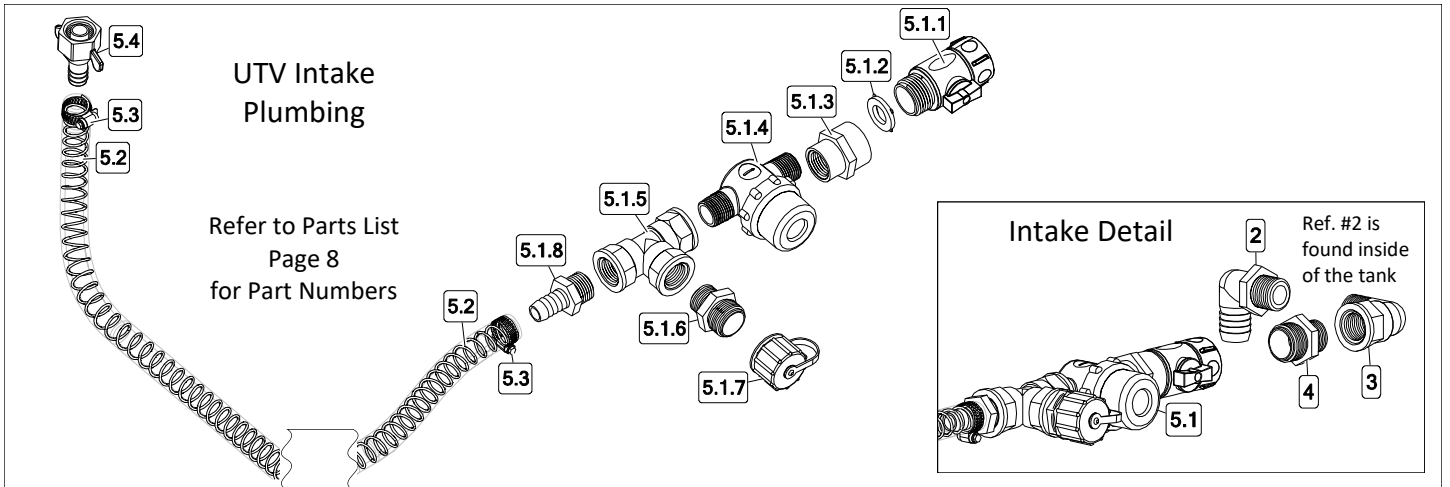
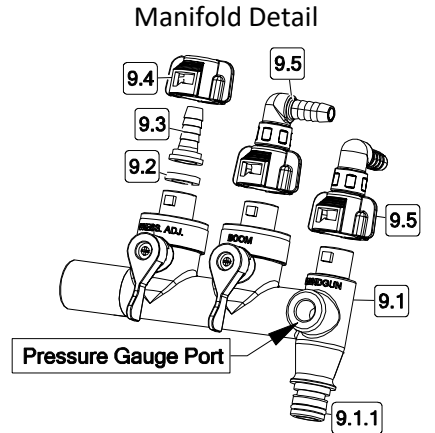

Long Range Pro Series Handgun

- No Drip Shut Off • Easy Pull Trigger Handle • Chemical Resistant Construction
- 38' Horizontal Throw & 27' Vertical Throw

To adjust the spray pattern, the nut needs to be adjusted (Ref. A). Spinning it off, towards the lever, will make a cone pattern and spinning it on, away from the lever, will make a stream. The lever (Ref. B), is the lock that can be used to lock the lever when pulled, holding the valve open. Squeezing the trigger, will release the lock.

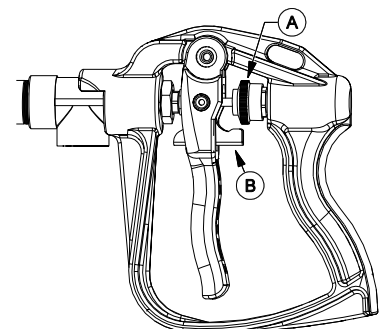

Opposite Side has Typical Hardware Setup

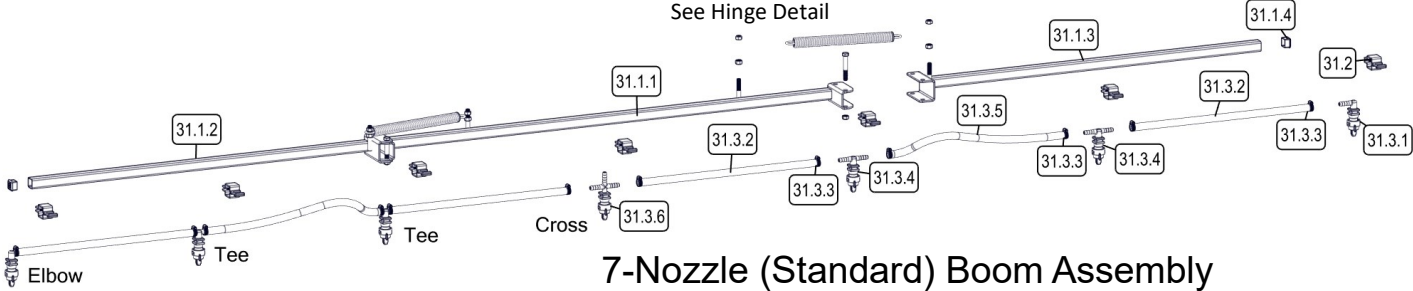

7-Nozzle (Standard) Boom Assembly (with 3/8" Hose, 1" Sq. Tubing & AIXR11002VP Tips)

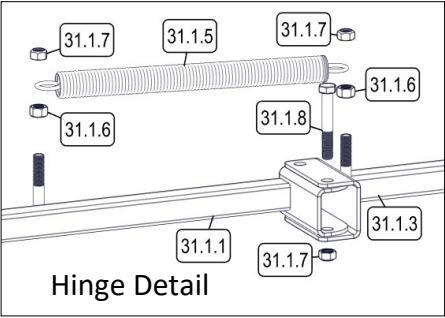
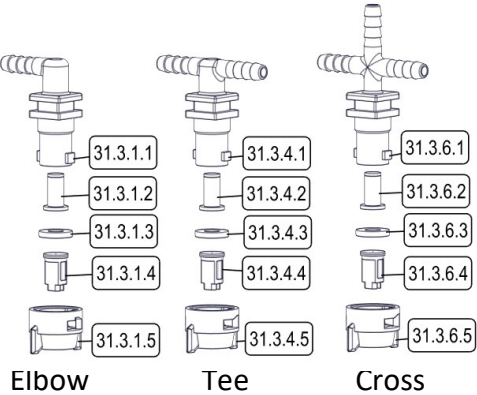

Ref. #	Part #	Description	Qty
31	5301897	7-Nozzle Boom Assembly	1
31.1	5277780	7-Nozzle Boom	1
31.1.1	5277838-BLK	Center Boom Weldment 1" Sq. Tube	1
31.1.2	5277837-BLK	Outer Boom Weldment (LH) (1" Sq Tube)	1
31.1.3	5277836-BLK	Outer Boom Weldment (RH) (1" Sq Tube)	1
31.1.4	5046106	Square Cap, Black (1" Square Tube)	2
31.1.5	5019228	Extension Spring	2
31.1.6	5006259	3/8"-16 Flange Hex Whiz Locknut	4
31.1.7	5006345	3/8"-16 Flange Locknut	6
31.1.8	5034169	H.H.C.S., 3/8"-16 x 2 1/2"	2
31.2	5277923	Nozzle Clamp (1" Sq. Tube)	7
31.3	5277696	7-Nozzle Harness (3/8")	1
31.3.1	5281304	"ELL" Nozzle Sub-Assembly (3/8")	2
31.3.1.1	5056113	Single Hose Shank (3/8" Hose)	1
31.3.1.2	5143543	Check Valve Strainer, 50 Mesh, 5 PSI	1
31.3.1.3	5016157	Seat Washer (QJ Caps)	1
31.3.1.4	5018371	Air-Induction XR Flat Spray Tip (AIXR11002VP)	1

Ref. #	Part #	Description	Qty
31.3.1.5	5046219	Quick TeeJet Cap ONLY (Yellow)	1
31.3.2	5020510	Hose, 3/8"-1 Brd. x 19-3/8"	4
31.3.3	5051144	Hose Clamp, 3/8"	12
31.3.4	5281307	"TEE" Nozzle Sub-Assembly (3/8")	4
31.3.4.1	5056114	Double Hose Shank (3/8" Hose)	1
31.3.4.2	5143543	Check Valve Strainer, 50 Mesh, 5 PSI	1
31.3.4.3	5016157	Seat Washer (QJ Caps)	1
31.3.4.4	5018371	Air-Induction XR Flat Spray Tip (AIXR11002VP)	1
31.3.4.5	5046219	Quick TeeJet Cap ONLY (Yellow)	1
31.3.5	5020511	Hose, 3/8"-1 Brd. x 21"	2
31.3.6	5281308	"Cross" Nozzle Sub-Assembly (3/8")	1
31.3.6.1	5056115	Triple Hose Shank (3/8" Hose)	1
31.3.6.2	5143543	Check Valve Strainer, 50 Mesh, 5 PSI	1
31.3.6.3	5016157	Seat Washer (QJ Caps)	1
31.3.6.4	5018371	Air-Induction XR Flat Spray Tip (AIXR11002VP)	1
31.3.6.5	5046219	Quick TeeJet Cap ONLY (Yellow)	1

Based on the minimum overlap required to obtain uniform distribution with 110° tips and 20" spacing.
Suggested Minimum Spray Height: 16"-18" above what is being sprayed (to plant, not ground).
Optimum Spray Height: 20"

- 110° wide, tapered flat spray angle with air induction technology for better drift management.
- Made of 2-piece UHMWPE polymer construction which provides excellent chemical resistance, including acids, as well as exceptional wear life.
- Compact size to prevent tip damage.
- Excellent for systemic products and drift management.

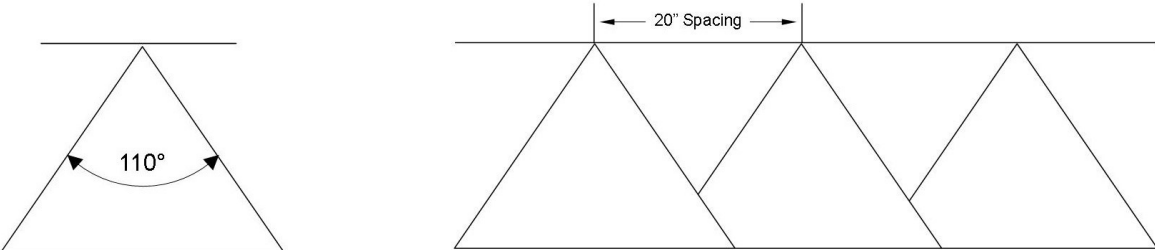

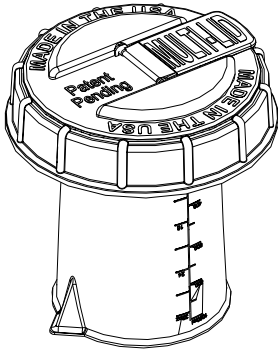

Multi-Lid Directions

1. Open fill cap and place garden hose into tank. Fill tank to desired gallon marker, if marker is above the bottom of calibration container, stop before water reaches calibration container. This is done to help chemical mix better and keep foaming of chemical to a minimum later.
2. Remove Multi-Lid and use calibration container to measure the correct amount of chemical for the water being used.
3. Pour chemical into tank and tighten Multi-Lid back onto tank. If desired amount of water was added in step 1, you are done. Be sure to press firmly on fill cap to seal with Multi-Lid. If desired amount of water was not met in step 1, proceed to step 4.
4. Open fill cap and place garden hose into tank. Add water to the desired gallon marker. Close fill cap, pressing firmly to seal cap to Multi-Lid.

NOTE: If water and chemical has not mixed properly, use the pressure adjustment control on the manifold to recirculate the mixture through tank.

Approx. Dimensions:

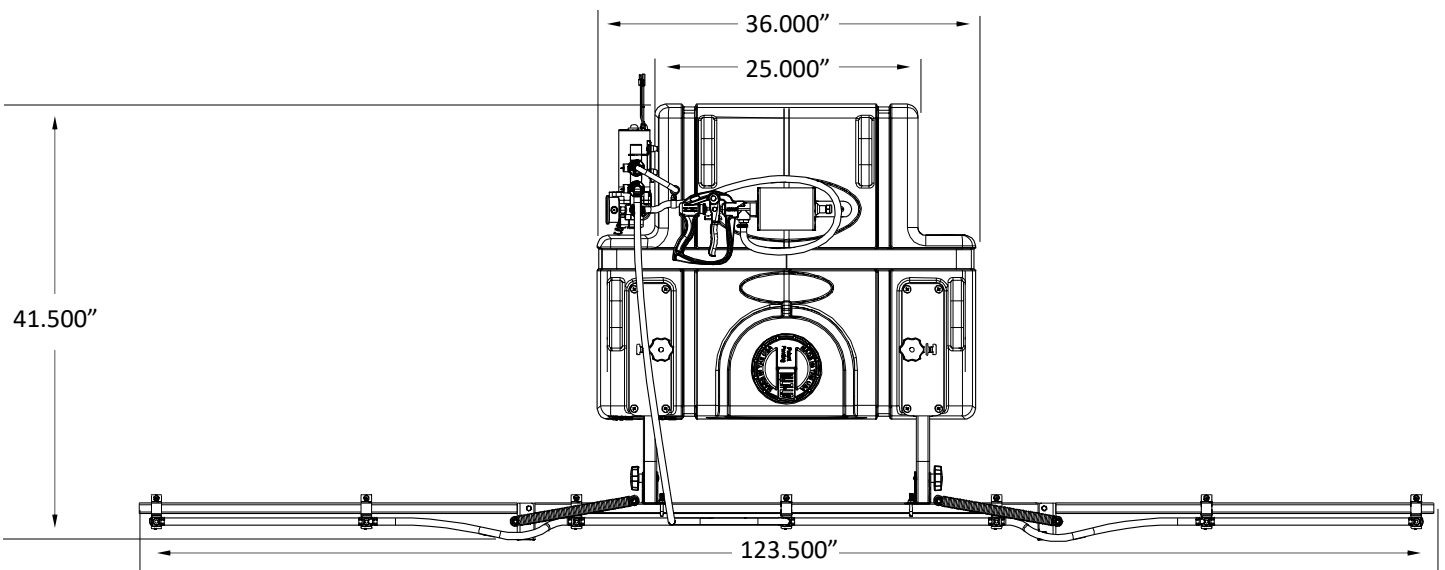
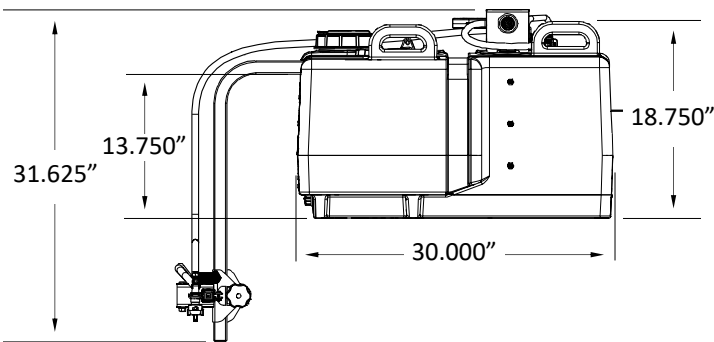

- ◆ Properly secure the tank to your utility vehicle, using tie-down or ratchet straps (Not Included).
- ◆ Tank straps may be installed through the handles to help prevent straps from slipping off tank if too loose.
- ◆ Handles can be used to lift the empty tank in and out of the box.
- ◆ Stay within your utility vehicle's weight limits. This unit when filled with water weighs approximately: 470 lbs. Consult the owner's manual for your vehicle.

NOTES:

Warranty

LIMITED WARRANTY FOR NEW FIMCO, IND. EQUIPMENT

WHO MAY USE THIS LIMITED WARRANTY. This limited warranty (the "Limited Warranty") is provided by Fimco, Ind. to the original purchaser ("you") of the Equipment (as defined below) from Fimco, Ind. or one of Fimco, Ind.'s authorized dealers. This Limited Warranty does not apply to any subsequent owner or other transferee of the Equipment. THIS LIMITED WARRANTY GIVES YOU SPECIFIC LEGAL RIGHTS, AND YOU MAY ALSO HAVE OTHER RIGHTS WHICH VARY FROM STATE TO STATE.

WHAT THIS LIMITED WARRANTY COVERS AND FOR HOW LONG. Fimco, Ind. warrants that any new Equipment will be free from defects in material and workmanship for a period of **one (1) year** for homeowner, **90 days** for commercial user, after delivery of the Equipment to you (the "Warranty Period"). The Warranty Period is not extended if Fimco, Ind. repairs or replaces the Equipment.

WHAT IS NOT COVERED BY THIS LIMITED WARRANTY. This Limited Warranty does not apply to: (1) used Equipment; (2) any Equipment that has been altered, changed, repaired or treated since its delivery to you, other than by Fimco, Ind. or its authorized dealers; (3) damage or depreciation due to normal wear and tear; (4) defects or damage due to failure to follow Fimco, Ind.'s operator's manual, specifications or other written instructions, or improper storage, operation, maintenance, application or installation of parts; (5) defects or damage due to misuse, accident or neglect, "acts of God" or other events beyond Fimco, Ind.'s reasonable control; (6) accessories, attachments, tools or parts that were not manufactured by Fimco, Ind., whether or not sold or operated with the Equipment; or (7) rubber parts, such as tires, hoses and grommets.

HOW TO OBTAIN WARRANTY SERVICE. To obtain warranty service under this Limited Warranty, you must (1) provide written notice to Fimco, Ind. of the defect during the Warranty Period and within **thirty (30)** days after the defect becomes apparent or the repair becomes necessary, at the following address: Fimco, Ind., 1000 Fimco Lane, North Sioux City, SD 57049; and (2) make the Equipment available to Fimco, Ind. or an authorized dealer within a reasonable period of time. For more information about this Limited Warranty, please call: **800-831-0027**.

WHAT REMEDIES ARE AVAILABLE UNDER THIS LIMITED WARRANTY. If the conditions set forth above are fulfilled and the Equipment or any part thereof is found to be defective, Fimco, Ind. shall, at its own cost, and at its option, either repair or replace the defective Equipment or part. Fimco, Ind. will pay for shipping and handling fees to return the repaired or replacement Equipment or part to you.

LIMITATION OF IMPLIED WARRANTIES AND OTHER REMEDIES. THE REMEDIES DESCRIBED ABOVE ARE YOUR SOLE AND EXCLUSIVE REMEDIES, AND FIMCO, IND.'S SOLE LIABILITY, FOR ANY BREACH OF THIS LIMITED WARRANTY. TO THE EXTENT APPLICABLE, ANY IMPLIED WARRANTIES, INCLUDING, WITHOUT LIMITATION, THE IMPLIED WARRANTIES OF MERCHANTABILITY AND FITNESS FOR A PARTICULAR PURPOSE, SHALL BE LIMITED IN DURATION TO THE WARRANTY PERIOD, AND THE REMEDIES AVAILABLE FOR BREACH THEREOF SHALL BE LIMITED TO THE REMEDIES AVAILABLE UNDER THIS EXPRESS LIMITED WARRANTY. SOME STATES DO NOT ALLOW LIMITATIONS ON HOW LONG AN IMPLIED WARRANTY LASTS, SO THE ABOVE LIMITATION MAY NOT APPLY TO YOU. IN NO EVENT SHALL FIMCO, IND.'S LIABILITY UNDER THIS LIMITED WARRANTY EXCEED THE ACTUAL AMOUNT PAID BY YOU FOR THE DEFECTIVE EQUIPMENT, NOR SHALL FIMCO, IND. BE LIABLE, UNDER ANY CIRCUMSTANCES, FOR ANY CONSEQUENTIAL, INCIDENTAL, SPECIAL OR PUNITIVE DAMAGES OR LOSSES, WHETHER DIRECT OR INDIRECT. SOME STATES DO NOT ALLOW THE EXCLUSION OR LIMITATION OF INCIDENTAL OR CONSEQUENTIAL DAMAGES, SO THE ABOVE LIMITATION OR EXCLUSION MAY NOT APPLY TO YOU.