

TERRAKING™

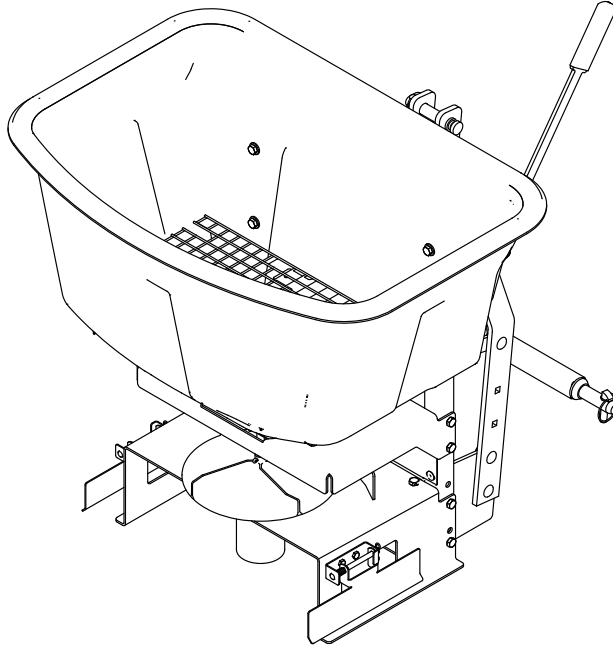

45-0633 **3 CU FT 3-POINT SPREADER** **THANK YOU** **FOR YOUR PURCHASE!**

Without your product review, we don't exist.

If you are happy with our quality products & service, please take just a moment to leave positive feedback and a short review of our product on our website or your retailer's website.

Not totally satisfied?

If you have any issues, don't hesitate to contact us. We make mistakes sometimes, but please give us the chance to make it right before leaving negative feedback against our product.

Customer Care
M-F 7:00 a.m. - 5:00 p.m. CST
800-448-9282
www.agri-fab.com



	2
ENGLISH.....	6

Spreader Frame Parts Diagram

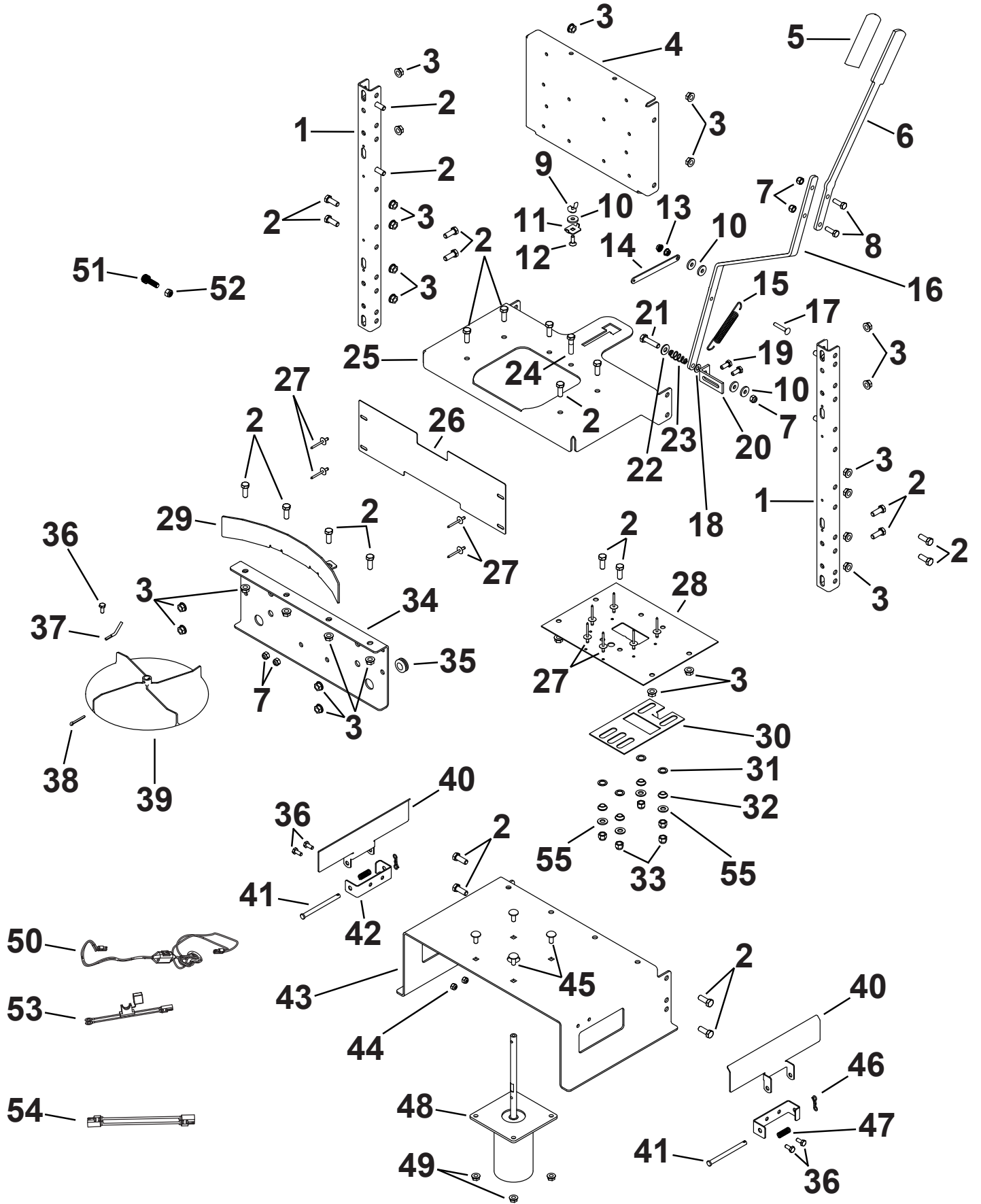

Spreader Frame Parts Diagram

REF. NO.	PART NO.	QTY.	DESCRIPTION	REF. NO.	PART NO.	QTY.	DESCRIPTION
1	2-948BL3	2	Channel	30	2-967	1	Plate, Gate
2	4-73	27	Bolt, 3/8-16 x 1" Hex SS	31	4-91	4	Washer, 3/4" Flat
3	ST65126	28	Nut, 3/8" Flange SS	32	4-112	4	Spacer, Nylon Shoulder
4	2-949BL3	1	Bracket, Module	33	ST65127	5	Nut, 3/8-16 Hex Nylock SS
5	47707	1	Grip, Handle	34	2-1134BL3	1	Bracket, Lower Frame
6	2-1401BL3	1	Handle, Upper	35	ST43844	1	Grommet
7	47810	5	Nut, 5/16-18 Hex Nylock	36	ST65120	5	Bolt, 1/4" x 5/8" Hex SS
8	43063	2	Bolt, 5/16-18 x 1" Hex	37	2-957	1	Agitator
9	47141	1	Nut, 1/4-20 Nylon Wing	38	41631	1	Pin, 5/32" x 1-1/4" Cotter
10	1543-69	5	Washer, 3/4" Nylon	39	2-958	1	Spinner
11	24858	1	Stop, Adjustable	40	2-970BL3	2	Bracket, Shield
12	44950	1	Bolt, 1/4-20 x 3/4" Carriage	41	4-72	2	Pin, 5/16" x 3-25/32" Clevis
13	ST65073	2	Nut, 1/4-20 Flange	42	2-969BL3	2	Bracket, Deflector
14	2-1346	1	Bracket, Connector	43	2-950BL3	1	Bracket, Mount
15	HA20186	1	Spring, Idler	44	49891	4	Nut, 1/4-20 Hex Nylock SS
16	2-1347BL3	1	Handle, Lower	45	ST65122	4	Bolt, 5/16" x 3/4" SS Short Neck Carriage
17	46000	1	Bolt, 1/4-20 x 1-1/2" Carriage	46	ST43624	2	Clip, Small Bowtie
18	48015	1	Washer, 11/16" Nylon	47	41036	2	Spring, Compression
19	43182	2	Bolt, 5/16-18 x 3/4" Hex	48	2-952	1	12V Motor
20	23442	1	Bracket, Handle Mounting	49	ST65124	4	Nut, 5/16" Flange SS
21	43084	1	Bolt, 5/16-18 x 1-3/4" Hex	50	ST43472	1	Harness, Switch
22	43081	1	Washer, 7/8"	51	4-71	1	Screw, 8-32 x 1/2" Sockethead
23	HA19445	1	Spring, Lock	52	4-69	1	Nut, 8-32 Hex Nylock SS
24	4-102	1	Bolt, 3/8-16 x 1-1/2" Hex SS	53	ST43483	1	Fuse, Battery Harness w/ 15A
25	2-1344BL3	1	Plate, Support	54	ST43485	1	Harness, 30" Extension
26	2-959	1	Shield	55	ST65112	4	Washer, 3/8" Flat SS
27	41157	10	Rivet, 3/16" Pop	-	3-402	1	Owner's Manual
28	2-965	1	Plate, Spreader	-	ST48616	1	Tie, 0.375 Fir Tree w/ Nylon Zip
29	2-1135BL3	1	Bracket, Spinner Shield	-	726-0178	6	Tie, T50R Nylon (Cable)
				-	3-502	1	Label, Register Adjustment

Hopper Parts Diagram

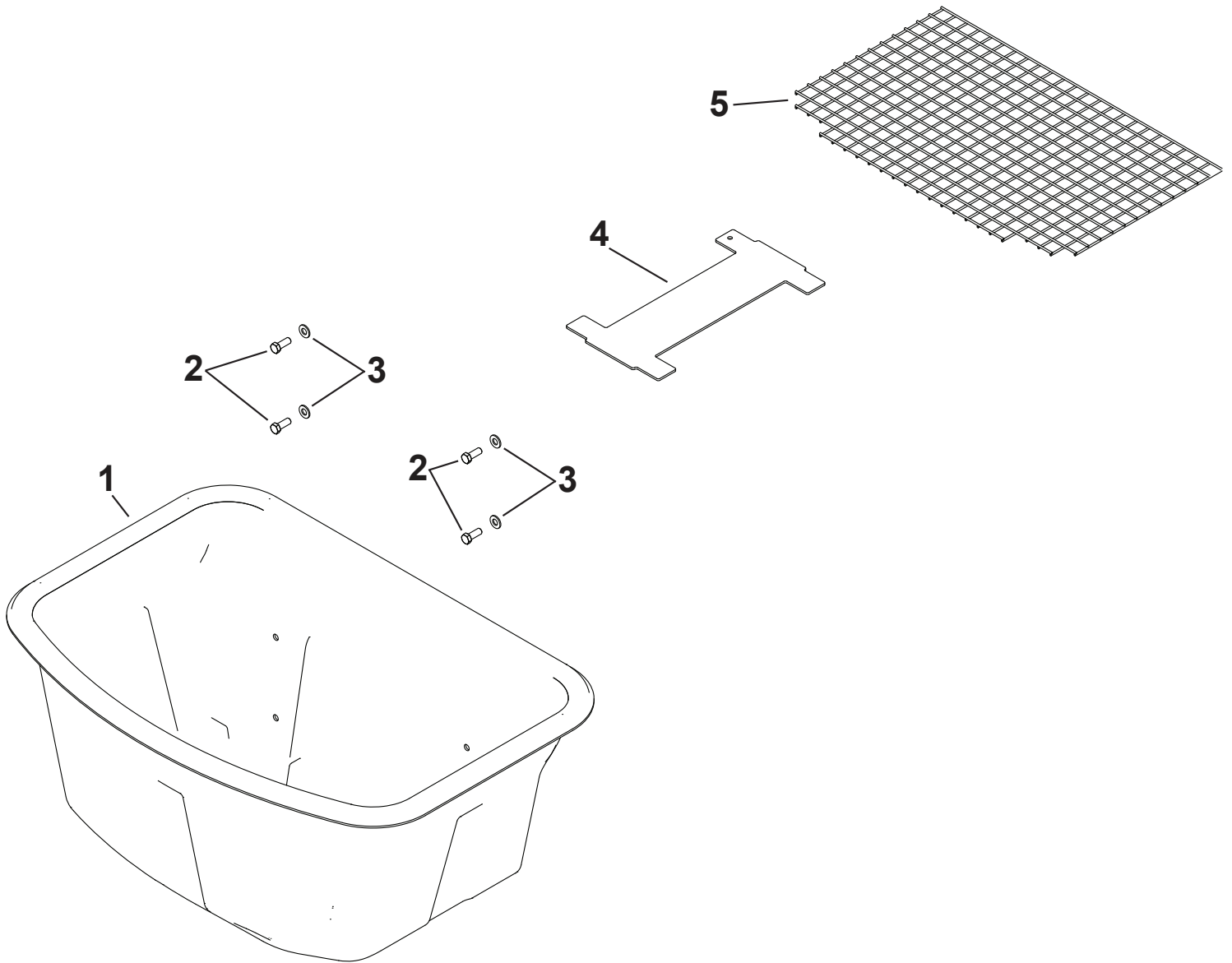

REF. NO.	PART NO.	QTY.	DESCRIPTION
1	2-961-001	1	Hopper, 3 Cu Ft
2	4-73	4	Bolt, 3/8-16 x 1" Hex SS
3	ST65112	4	Washer, 3/8" Flat SS
4	2-1410BL3	1	Diverter, Material Flow
5	2-981	1	Grate
-	2-964	1	Cover

Hitch Parts Diagram

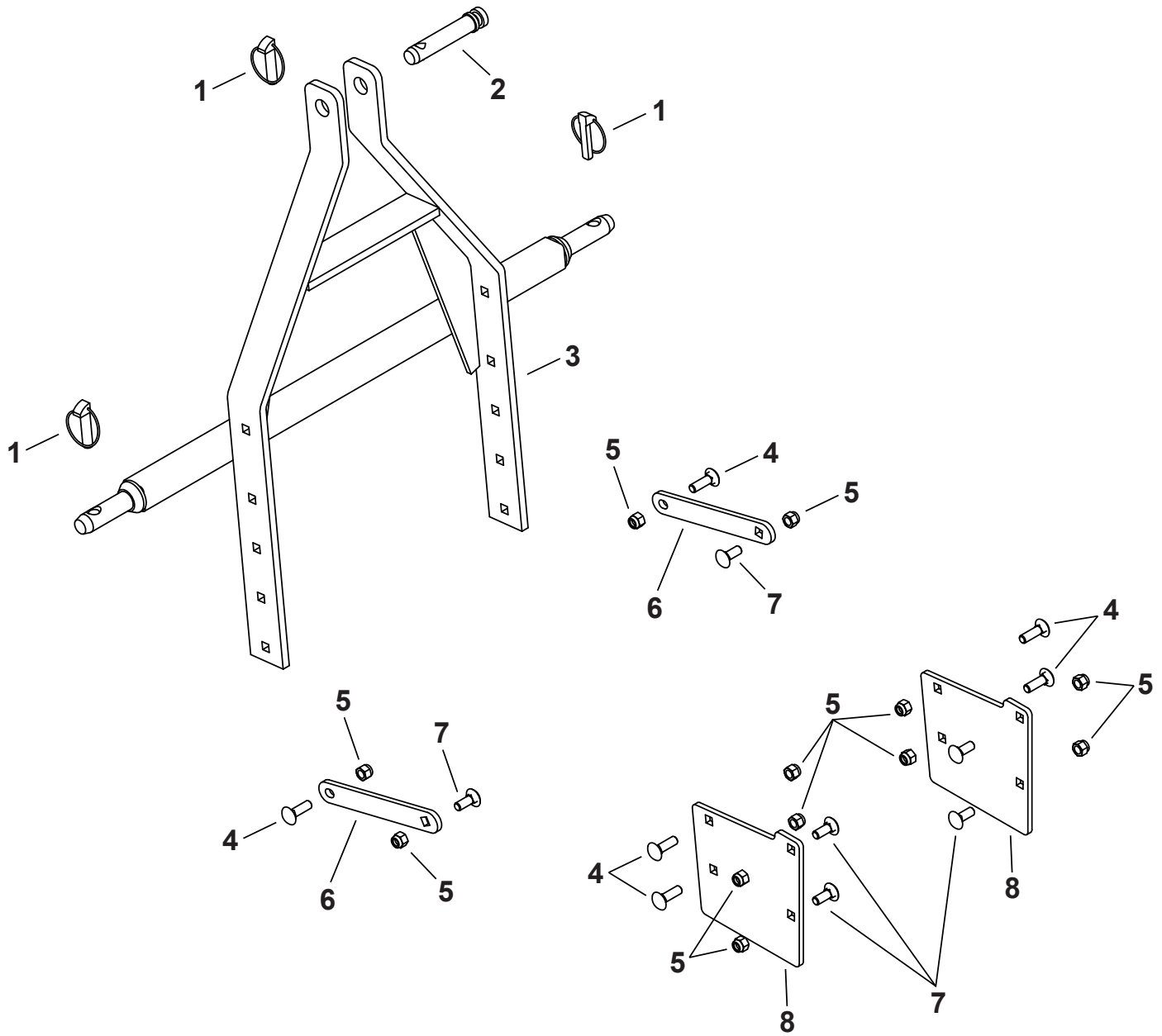

REF. NO.	PART NO.	QTY.	DESCRIPTION
1	ST43398	3	Pin, Lynch
2	ST43399	1	Pin, Cat. 1 Top
3	ST61500BL3	1	Frame, 3 Point Main
4	4-30	6	Bolt, 3/8-16 x 1-1/4" Carriage
5	HA21362	12	Nut, 3/8-16 Hex Nylock
6	ST50464BL3	2	Brace, 3 Point Hitch
7	43350	6	Bolt, 3/8-16 x 1" Carriage
8	2-976BL3	2	Bracket, Lower 3 Point

SAFETY

Read Safety in Machine Operator's Manual

Read the general safety operating precautions in your machine operator's manual.

Operating Safety

- Read the machine and attachment operator's manual carefully. Be thoroughly familiar with the controls and the proper use of the equipment. Know how to stop the machine and disengage the controls quickly.
- This attachment is intended for use in property maintenance applications. Do not use for use other than intended by the manufacturer. Do not modify machine or safety devices. Unauthorized modifications to the machine or attachment may impair its function and safety.
- Do not let children or an untrained person operate machine.
- Make any necessary adjustments before you operate. Never attempt to make any adjustments while the engine is running, unless it is recommended in adjustment procedure.
- Look behind machine before you back up. Back up carefully.
- Never carry passengers, especially children, on machine or attachment. Riders are subject to injury such as being struck by foreign objects and being thrown off. Riders may also obstruct the operator's view, resulting in the machine being operated in an unsafe manner.
- Disengage any power to the attachment when the machine is transported or not in use.
- Never exceed 15 mph when loaded spreader is attached to vehicle. Braking distances may be increased and handling characteristics may be impaired at speeds above 15 mph.
- Never use wet materials or materials with foreign debris in the spreader. This unit is designed to spread dry, clean, free-flowing material.
- Never leave material in hopper when not in use.
- Weight of mounted machines, including their loads, can influence vehicle maneuverability. Refer to vehicle OM for ballasting.

Practice Safe Maintenance

- Only qualified, trained adults should service this machine.
- Understand service procedure before doing work. Keep area clean and dry.
- Do not operate the engine in a confined space where dangerous carbon monoxide fumes can collect.
- Never lubricate, service or adjust the machine or attachment while it is moving. Keep safety devices in place and in working condition. Keep hardware tight.
- Keep hands, feet, clothing, jewelry, and long hair away from any moving parts, to prevent them from getting caught.

- Lower any attachment completely to the ground or to an existing attachment mechanical stop before servicing the attachment. Disengage all power and stop the engine. Lock park brake and remove the key. Let machine cool.
- Disconnect the negative battery cable(s) before making any repairs.
- Before servicing machine or attachment, carefully release pressure from any components with stored energy, such as hydraulic components and springs..
- Securely support any machine or attachment elements that must be raised for service work. Use jack stands or lock service latches to support components when needed.
- Never run engine unless park brake is locked.
- Keep all parts in good condition and properly installed. Fix damage immediately. Replace worn or broken parts. Replace all worn or damaged safety and instruction decals.
- Check all hardware at frequent intervals to be sure the equipment is in safe working condition.
- Do not modify machine or safety devices. Unauthorized modifications to the machine or attachment may impair its function and safety.

Parking Safely

1. Stop vehicle on a level surface, not a slope.
2. Fully lower the cargo box and any attachments on the machine that can be lowered.
3. Fully engage parking brake and ensure vehicle is not moving.
4. Stop engine.
5. Remove key.
6. Before you leave the operator's seat, wait for the engine and all moving parts to stop.
7. Disconnect the negative battery cable before servicing the machine.

Wear appropriate clothing

- Always wear eye protection when operating the machine.
- Wear close fitting clothing and safety equipment appropriate for the job.
- While operating this machine, always wear substantial footwear and long trousers. Do not operate the equipment when barefoot or wearing open sandals.
- Wear a suitable protective device such as earplugs. Loud noise can cause impairment or loss of hearing.
- Always wear substantial footwear. Do not operate the equipment when barefoot or wearing open sandals

ASSEMBLY

Carton Kit

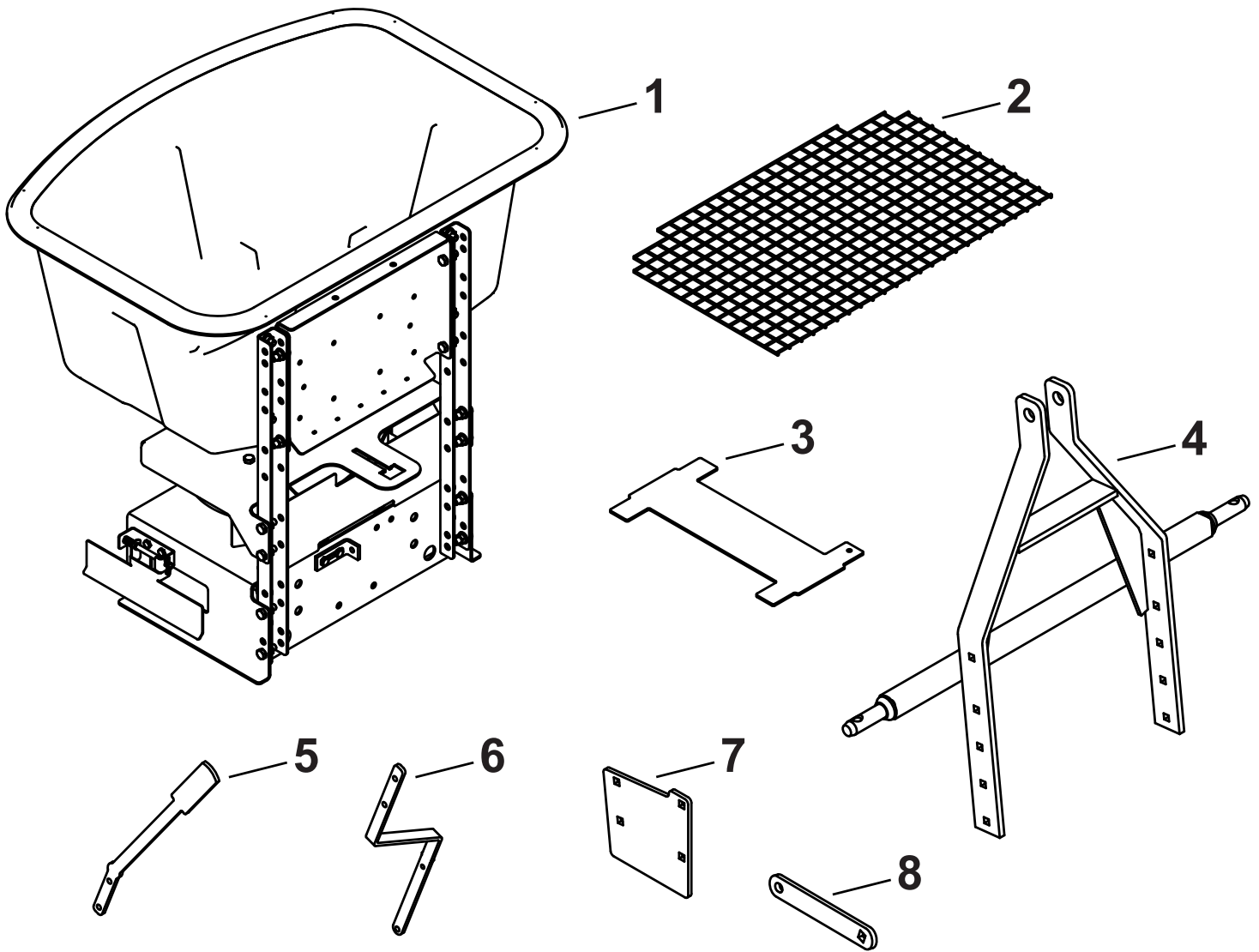

Parts not shown to scale

REF. NO.	PART NO.	QTY.	DESCRIPTION
1	-	1	Assembly, Spreader
2	2-981	1	Grate
3	2-1410BL3	1	Diverter, Material Flow
4	ST61500BL3	2	Frame, 3 Point Main
5	2-1401BL3	1	Handle, Upper
6	2-1347BL3	1	Handle, Lower
7	2-976BL3	1	Bracket, Lower 3 Point
8	ST50464BL3	2	Brace, 3 Point Hitch
-	2-964	1	Cover

ASSEMBLY

Hardware Kit

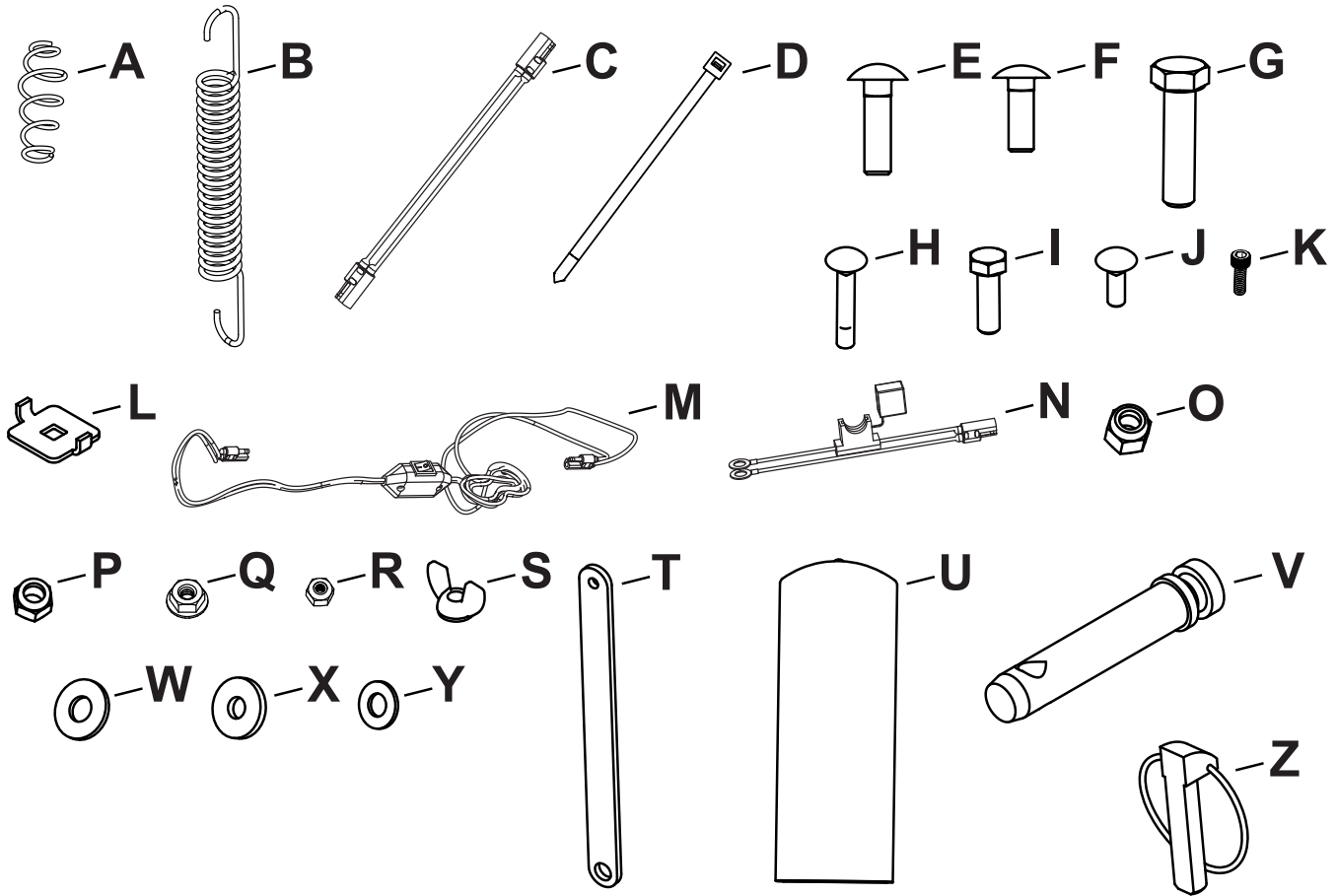

Parts not shown to scale

REF. NO.	PART NO.	QTY.	DESCRIPTION	REF. NO.	PART NO.	QTY.	DESCRIPTION
A	HA19445	1	Spring, Lock	N	ST43483	1	Harness, Battery
B	HA20186	1	Spring, Idler	O	HA21362	16	Nut, 3/8-16 Hex Nylock
C	ST43485	1	Harness, 30" Extension	P	47810	3	Nut, 5/16-18 Hex Nylock
D	4-30	6	Bolt, 3/8-16 x 1-1/4" Carriage	Q	ST65073	2	Nut, 1/4-20 Flange
E	43350	6	Bolt, 3/8-16 x 1" Carriage	R	4-69	1	Nut, 8-32 Hex Nylock SS
F	726-0178	6	Tie, T50R Nylon Cable	S	47141	1	Nut, 1/4-20 Nylon Wing
G	43084	1	Bolt, 5/16-18 x 1-3/4" Hex	T	2-1346	1	Bracket, Connector
H	46000	1	Bolt, 1/4-20 x 1-1/2" Carriage	U	47707	1	Grip, Handle
I	43063	2	Bolt, 5/16-18 x 1" Hex	V	ST43399	1	Pin, Cat. 1 Top
J	44950	1	Bolt, 1/4-20 x 3/4" Carriage	W	43081	1	Washer, 7/8"
K	4-71	1	Screw, 8-32 x 1/2" Sockethead	X	1543-69	5	Washer, 3/4" Nylon
L	24858	1	Stop, Adjustable	Y	48015	1	Washer, 11/16" Nylon
M	ST43472	1	Harness, Switch	Z	ST43398	3	Pin, Lynch

ASSEMBLY

TOOLS NEEDED

- 11/32" Wrench - 1 each
- 7/16" Wrenches - 2 each
- 1/2" Wrenches - 2 each
- 9/16" Wrenches - 2 each
- 9/64" Allen Wrench - 1 each

SPREADER ORIENTATION

1. Spreader orientation is based on looking from the front of the spreader. (See below)

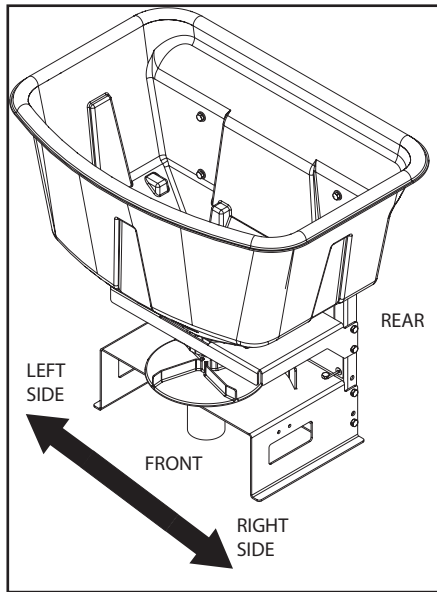

STEP 1: (SEE FIGURE 1)

- Install a 3/4" carriage bolt (J) into the adjustable stop (L).
- Install the bolt and stop into opening on the spreader support plate.
- Install a 3/4" nylon washer (X) onto the carriage bolt (J) and secure with a nylon wing nut (S).

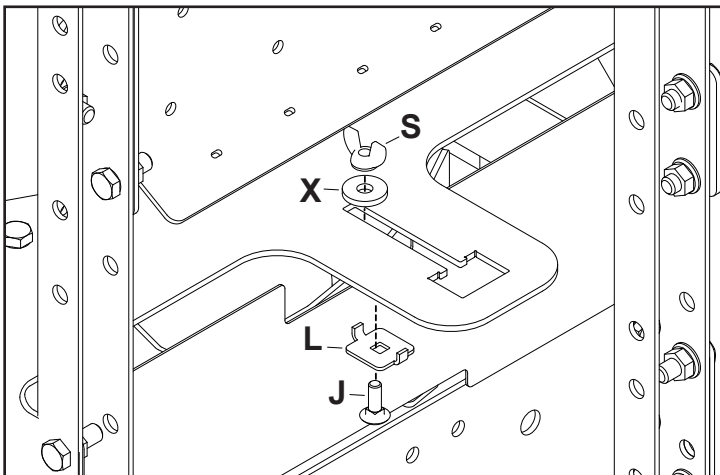

FIGURE 1

STEP 2: (SEE FIGURE 2)

NOTE: Ensure orientation of the connector bracket (T) is correct. Will need to use the small hole on the bracket for this step.

- Install the connector bracket (T) to the left of the tab on the gate plate with a sockethead screw (K).
- Secure screw with a 8-32 nylock nut (R).
- Tighten hardware and then loosen a 1/4 turn. To allow the bracket (T) to pivot.

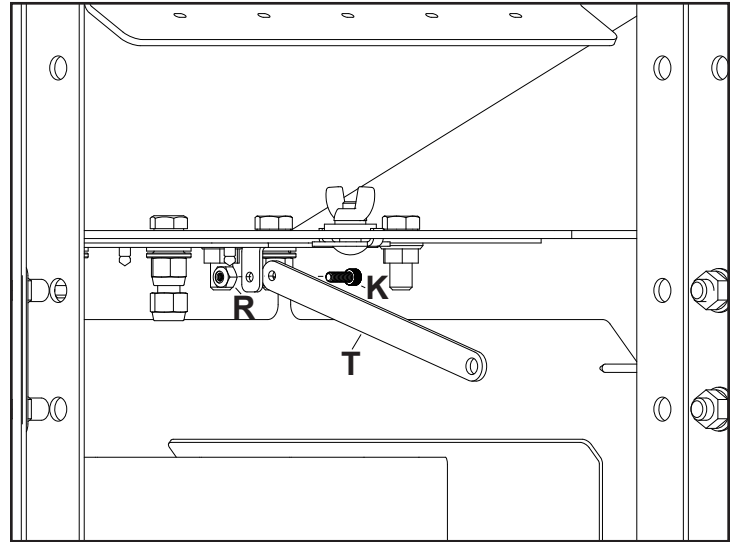

FIGURE 2

STEP 3: (SEE FIGURE 3)

- Install the lower handle (6) into the opening on the spreader support plate. Make sure the handle is orientated in the right direction. See image below.

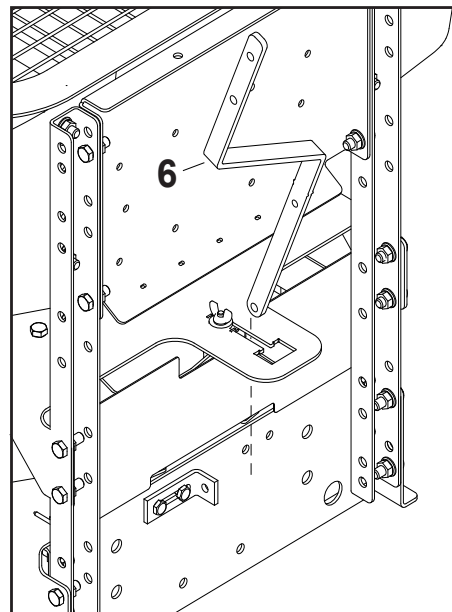

FIGURE 3

ASSEMBLY

STEP 4: (SEE FIGURE 4)

- Install a 5/16" x 1-1/4" bolt (G) through a 7/8" washer (W) and lock spring (A).
- Compress the lock spring (A) with the bolt (G) through the lower hole on the left side of the lower handle (6).
- Install a 11/16" nylon washer (Y) onto the bolt. Between the lower handle and the bracket.
- Install the bolt assembly through the bracket and secure with two 3/4" nylon washers (X) and a 5/16" nylock nut (P).
- Tighten hardware. May need to tighten or loosen hardware to allow the handle (6) to pivot.

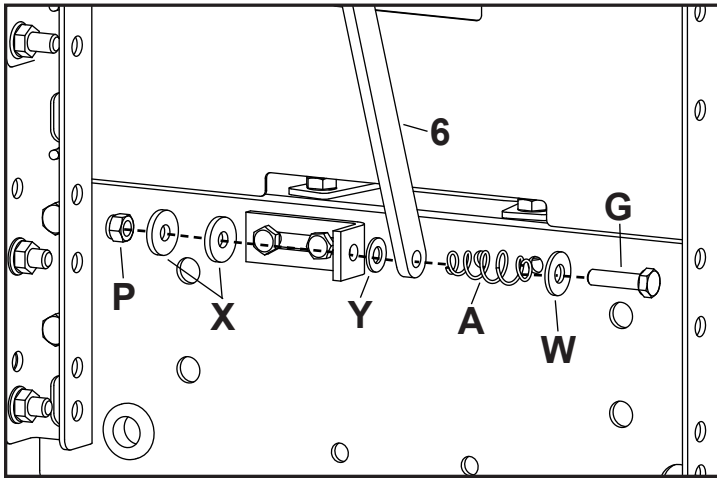

FIGURE 4

STEP 5: (SEE FIGURE 5)

- Install a 1/4" x 1-1/2" carriage bolt (H) through the right side of the lower handle (6). The carriage bolt head will stick out as shown in Figure 5)
- Install two 3/4" nylon washers (X) onto the bolt and then install the connector bracket (T) onto the bolt.
- Install a 1/4" flange nut (Q) head first onto the bolt and then install another 1/4" flange nut (Q) flange first.
- Tighten the the two 1/4" flange nuts (Q) together.

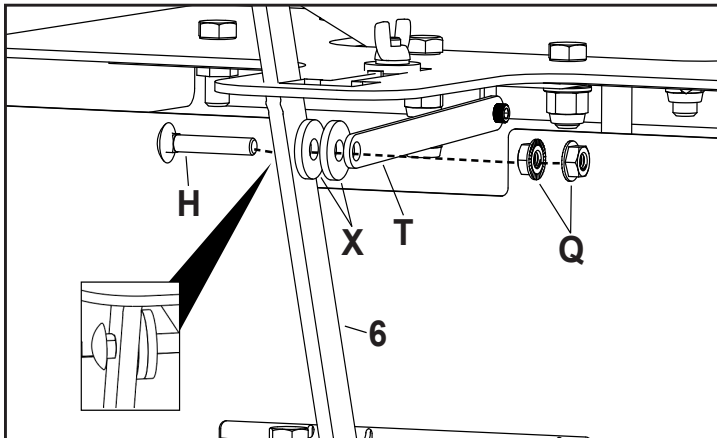

FIGURE 5

STEP 6: (SEE FIGURE 6)

- Install the idler spring (B) onto the bolt between the nylock nuts. (Located right of the tab on the gate plate)
- Route the spring towards the handle.

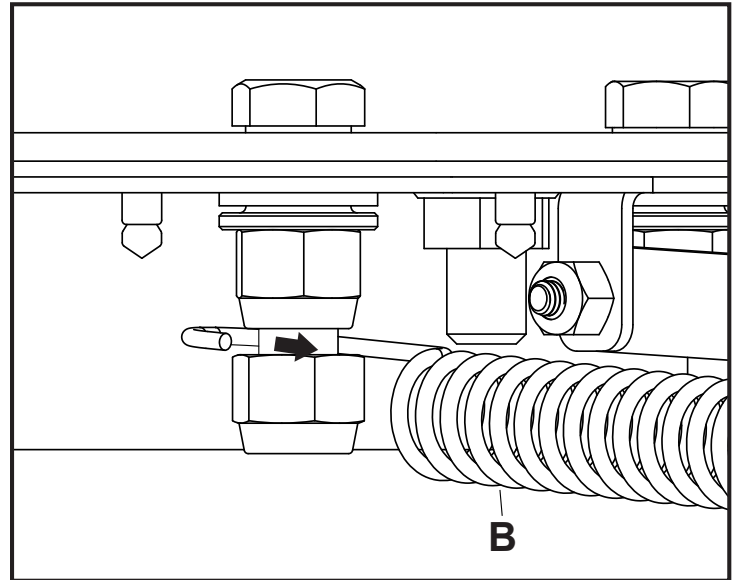

FIGURE 6

- Install the idler spring (B) onto the carriage bolt (H) square neck. (Carriage bolt was installed in Step 5)

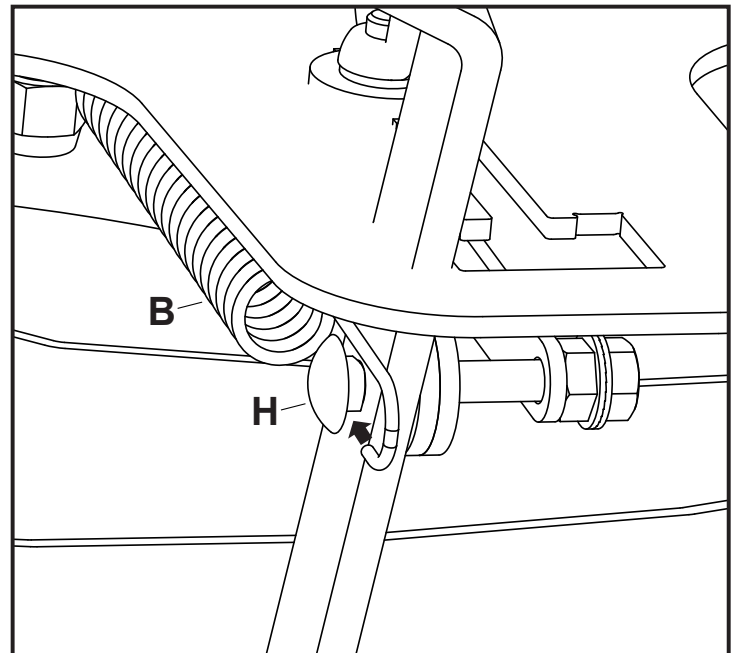

FIGURE 6

ASSEMBLY

STEP 7: (SEE FIGURE 7)

- Orientate a lower 3 point bracket (7) on the inside of the left channel. (Will use the 2nd and 4th hole from the bottom.)
- Install two 3/8" x 1" carriage bolts (F) through the lower bracket (7) and channel.
- Secure with two 3/8" nylock nuts (O) in the channel. Tighten hardware.
- Do not fully tighten hardware.
- Repeat on the right side.

NOTE: For easier tightening of the hardware. You can remove the two horizontal bolts going through the channel and the mount bracket. After tightening the hardware reinstall the removed hardware.

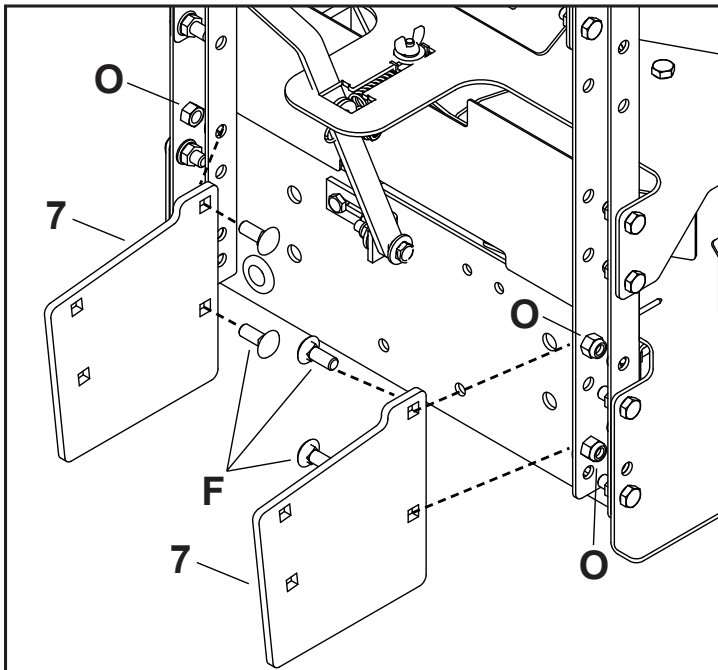

FIGURE 7

STEP 8: (SEE FIGURE 8)

- Orientate a 3 point hitch brace (8) with the side with square hole towards the spreader and on the inside of the channel. (Will use the 6th hole down on the channel.)
- Install a 3/8" x 1" carriage bolt (F) through the brace (8) and channel.
- Secure with two 3/8" nylock nuts (O) in the channel. Do not fully tighten hardware.
- Repeat on the right side.

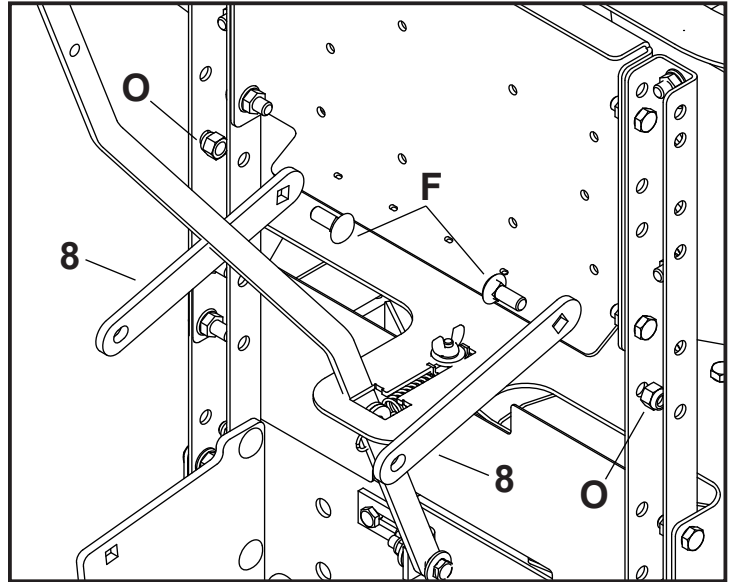

FIGURE 8

STEP 9: (SEE FIGURE 9)

- Place the 3 point main frame (4) over the outside of the lower 3 point brackets (7). The 3 point hitch braces (8) will go on the inside of the 3 point main frame (4). (Make sure the 3 point hitch tube is facing away from the spreader.)
- Install two 3/8" x 1-1/4" carriage bolts (E) on each side through the lower part of the 3 point main frame (4) and lower 3 point bracket (7).
- Secure with two 3/8" nylock nuts (O) on each side. Do not fully tighten hardware.
- Install a 3/8" x 1-1/4" carriage bolts (E) on each side through the upper part of the 3 point main frame (4) and the round hole on the 3 point hitch brace (8).
- Secure with a 3/8" nylock nuts (O) on each side. Tighten hardware.
- Tighten the rest of the hardware from Step 9, Step 8, and Step 7.

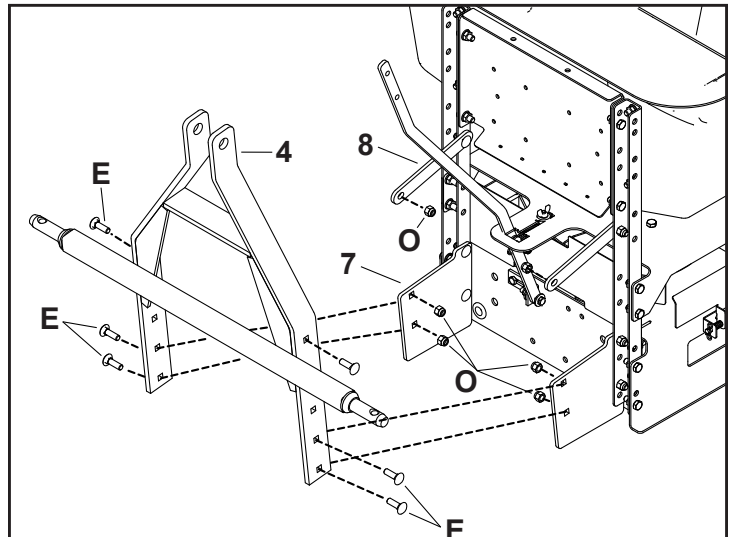

FIGURE 9

ASSEMBLY

STEP 10: (SEE FIGURE 10)

- Place the upper handle (5) to the lower handle (6). Make sure the top of the upper handle (5) is facing forward away from the spreader.
- Install two 5/16" x 1" bolts through the upper and lower handles. Securing with two 5/16" nylock nuts (P).
- Tighten hardware
- Install the handle grip (U) onto the upper handle (5).

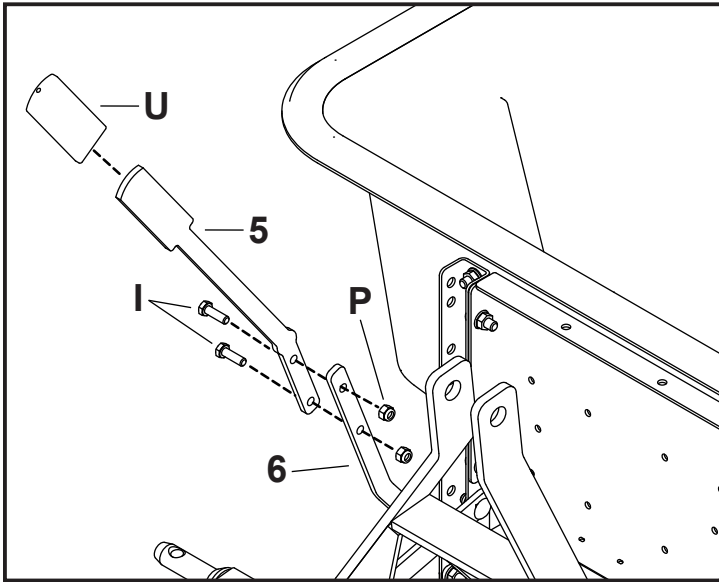

FIGURE 10

STEP 11: (SEE FIGURE 11)

- Install the material flow diverter (3) into the hopper in between the plastic notches.
- Install the grate (2) into the hopper as shown in Figure 11.

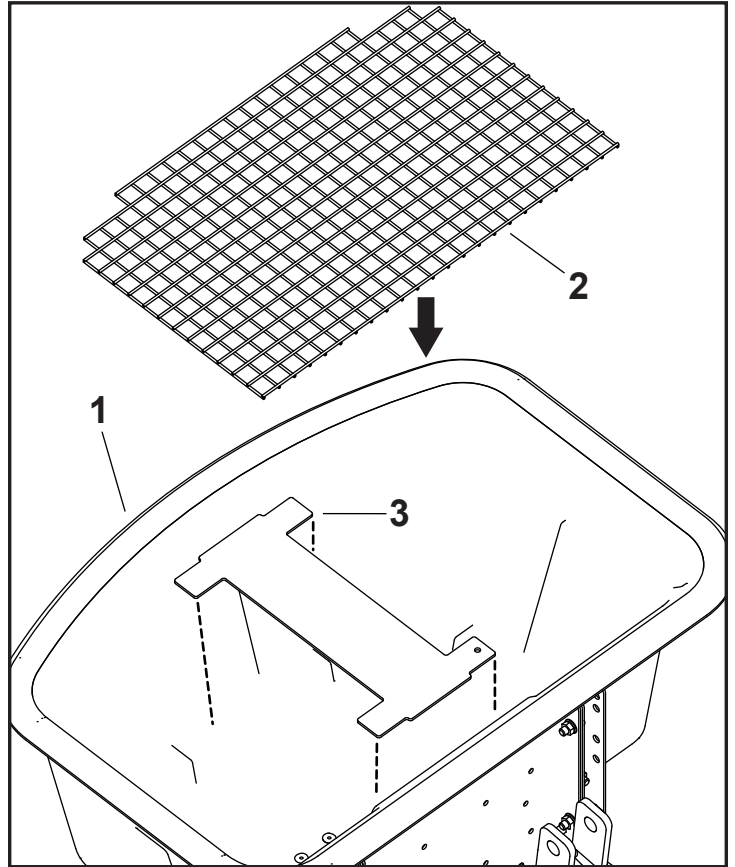
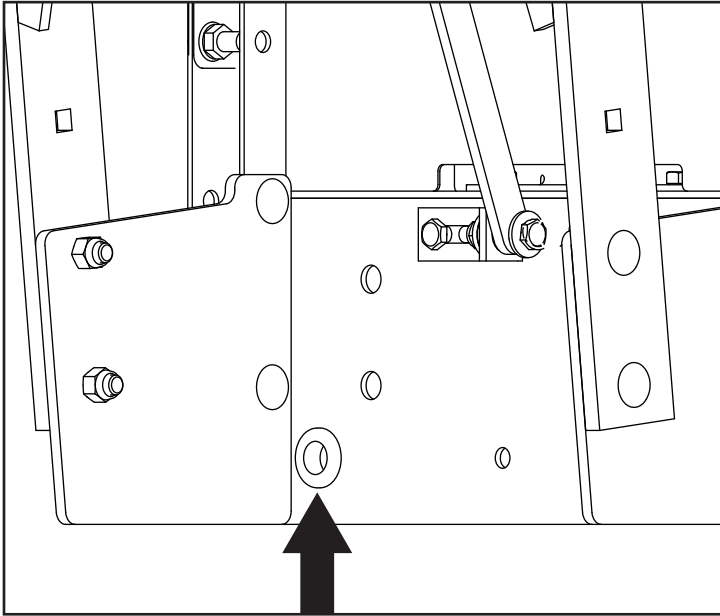

FIGURE 11

INSTALLATION

Installing Wire Harness to Spreader

- Route the one side of the 30" extension harness (C) through the hole with grommet to the motor area of the spreader.



- Connect the 30" extension harness (C) to the harness on the motor.

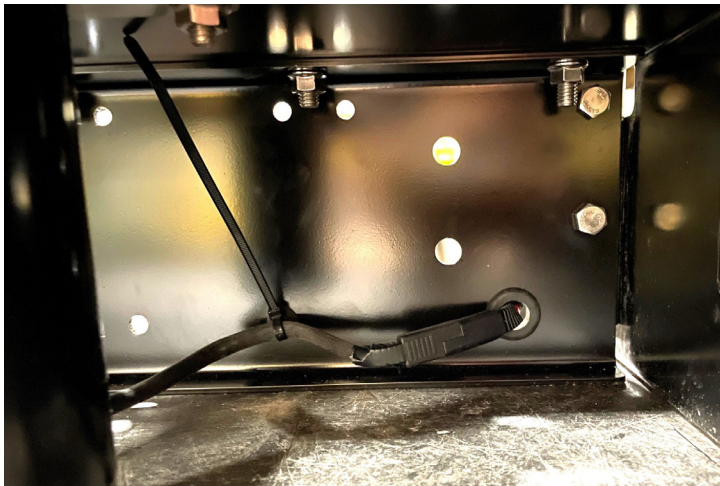

- Route the other end of the 30" Extension harness (C) up the lower 3 point bracket (7). Route the harness on the outside of the 3 point main frame (4) and secure with a cable tie (D).

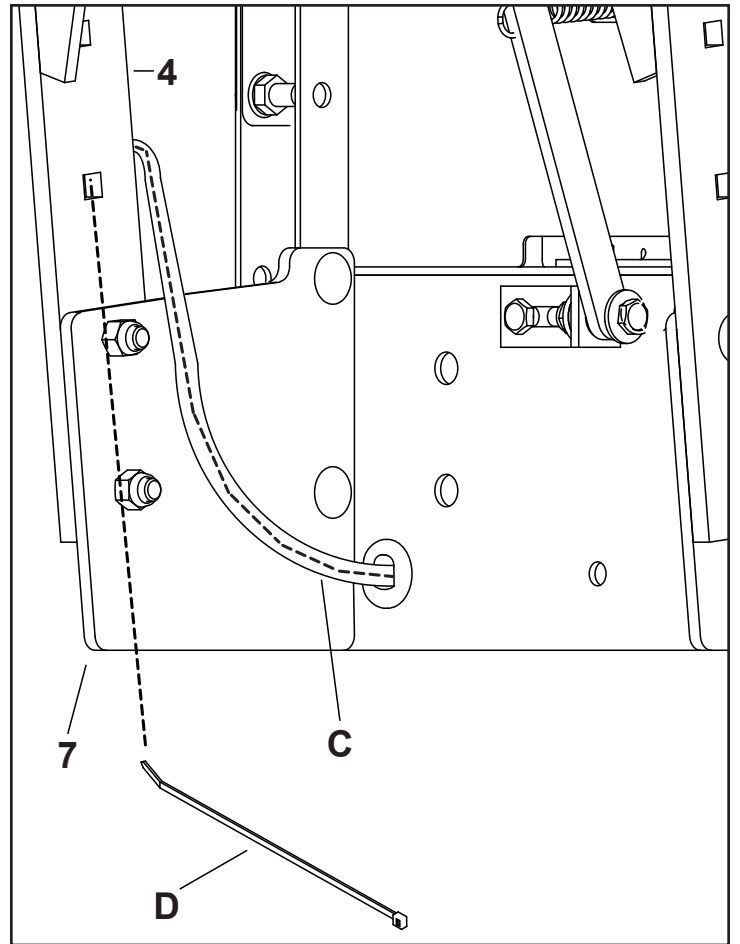

INSTALLATION

Attaching Spreader to Tractor

Note: See Ballasting Machine in your tractors operators manual to determine the number of front weights required to ballast the tractor.

1. Park machine safely. (See Parking Safely in Safety section.)
2. Lower tractor lift link to lowest position.
3. Mount the spreader onto the 3-Point hitch.
4. Secure the lower hitch pins with a lynch pin (Z) on each side.
5. Secure the top pin with a Cat. 1 top pin (V) and a lynch pin (Z).

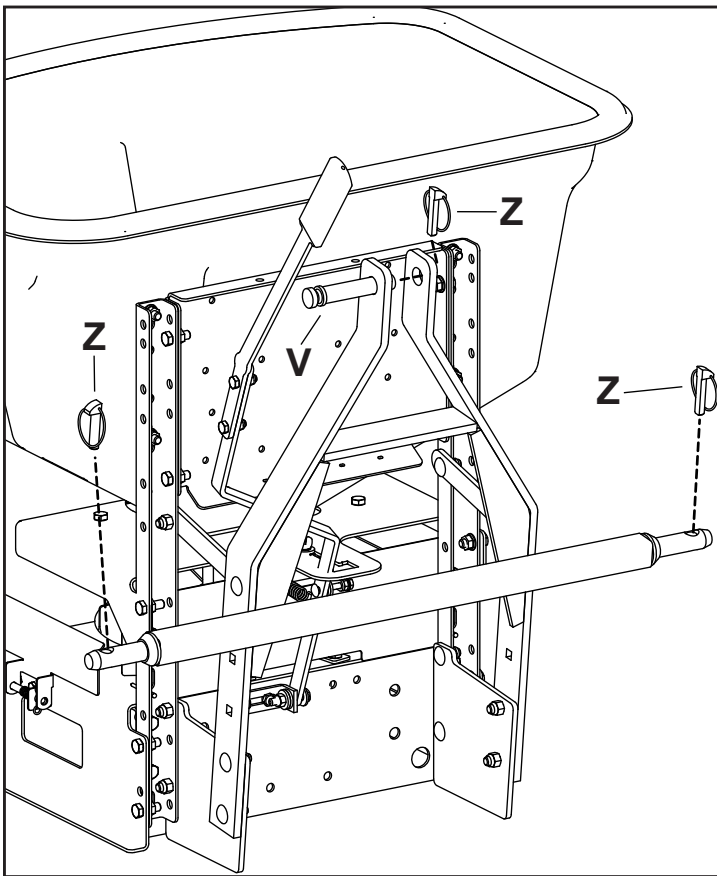

Installing Wire Harness to Tractor

- Attach battery harness (N) ring terminals to the battery. (Red to red and black to black)
- Attach the switch harness (M) to the battery harness (N). Depending on battery location may need to use either the short or long end from switch harness (M). Want the switch near the operator.
- Route the other end of the switch harness (M) towards the spreader.
- Attach the switch harness (M) to the 30" extension harness (C).
- Secure with a cable tie (D) where needed.

Note: Make sure to keep harnesses away from any moving parts and exhaust.

OPERATION

Spreader Components

Hopper	3 cu. ft. capacity, high density polypropylene molded hopper
Spinner Motor	12V DC motor drives a 12in spinner disk to distribute material
Gate Handle	Manually opens spreader gate

Spreader Features

Adjustable spread pattern for various materials
Barrier shield

****This spreader is for finer materials. Do not use spreader for rock salt. Recalibrate when switching between materials. Spreader is NOT compatible with Powdered Lawn Products****

Spreader Calibration

It is the responsibility of the person using this equipment to make sure that every type of material is properly calibrated to perform as expected. To achieve a safe and accurate reading for proper material distribution, calibration must take place on a solid flat surface away from drains and livestock areas. Failure to do so causes an over or under-application that damages turf areas. Any calibration charts contained in this manual are given as a reference point only and must not be used as an absolute condition. Spending a few extra minutes to calibrate not only saves on wasted materials and time but also protects turf and other vegetation.

Be aware of the following points before operating your spreader in the field:

Flow Rates

Flow rates of materials change for many reasons:

- Formulations vary within the same brand or even between brands.
- Formulations vary between batches or dates of manufacture.
- Humidity causes the material to clump and flow poorly.
- Poor spreader maintenance causes flow changes.
- Slide stop has moved or has been calibrated to another type of material.
- Human error causes rate miscalculation.

Items Needed for Calibration

- A way to catch the material for weighing.
- A device to measure distance.
- A scale to weigh your product.
- A stop watch or other device to measure time.

Conversion Factors

- To convert pounds per 1,000 sq. ft. to pounds per acre, multiply your rate by 43.6.
- To convert miles-per-hour to feet-per-minute, multiply miles-per-hour by 88.
- 1 acre is equal to 43,560 sq. ft.
- Ground speed is important to keep in mind when doing calculations; convert miles-per-hour to feet-per-minute.

Calibration

NOTE: To change the spread pattern, use the side shields.

To calibrate the spreader:

- Use a level, open area of pavement.
- Set the gate opening in the middle as a starting point.
- Fill the hopper with the material desired.
- Turn on the spreader with the switch on the switch harness (M).
- Determine the driving speed while spreading (in feet-per-minute).
- Determine desired application rate (converted to pounds-per-square-foot).

To determine the pounds-per-minute that the gate setting must allow, use the following equation:

Desired Application Rate (pounds-per-square-foot) x Spread Width (feet) x Speed (feet-per-minute) = Pounds-per-minute.

- Open the gate. The spinner must be operating during this step.
- Put a bucket or other means of catching material at the back of the spreader.
- Leave the gate open for one minute.
- Brush off all excess from the spinner and motor enclosures into the bucket.
- Weigh the bucket with material.
- Subtract the weight of the bucket when empty and record.
- To achieve the required "pounds-per-minute" rate, adjust the gate based on the result.

Once the setting is established, you are ready to spread. Record for future use on the notes page of this manual. Example record:

When spreading Material XYZ: Spinner speed 60% (width = 15 ft.), Drive 4.0 mph (352 fpm), Gate setting = 8

Operation

Spreader Gate Flow Rate Table

Gate Setting	UREA 46-0-0	Lesco Turface	Lesco Shade Mix	Lesco Fert. 30-0-10
2	7.15	2.11	x	3.84
4	31.36	14.70	0.66	23.94
6	47.70	x	1.78	39.38
8	73.59	x	8.72	64.64
10	93.52	57.32	11.94	91.32

Flow Rates are Calculated at Pounds-Per-Minute

Spreading

NOTE: Always use the hopper cover to prevent moisture buildup. Do not let spreader sit idle with material in the hopper for an extended period of time. This can cause material to compact, reduce or stop the flow of material and cause permanent hopper damage.



IMPORTANT: Never operate near pedestrians. Never exceed 10 mph while spreading. This spreader is for fertilizer salt. Not recommended for use with rock salt.



CAUTION: DO NOT leave unused material in hopper. Material can freeze or solidify, causing unit to not work properly. Empty and clean after each use.



CAUTION: Disconnect electric and tag out if required before servicing or performing maintenance.

The barrier shield (1) comes installed on both sides of the fertilizer spreader. To raise or lower the shield, push it against the spring (2) and rotate.

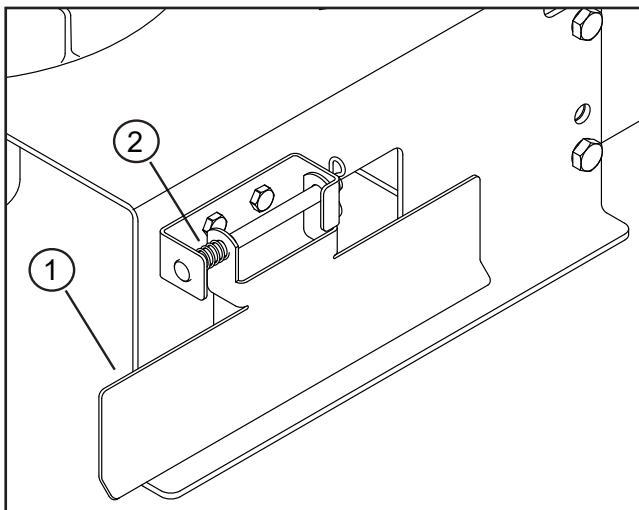

1. Set the adjustable stop (L) to the desired setting by loosening the wing nut (S) and sliding the adjustable stop (L). Once set retighten the wing nut (S).
2. Press the switch on the switch harness (M) ON.

Note: Make sure switch is off after use. If left on with tractor off may cause battery drainage.

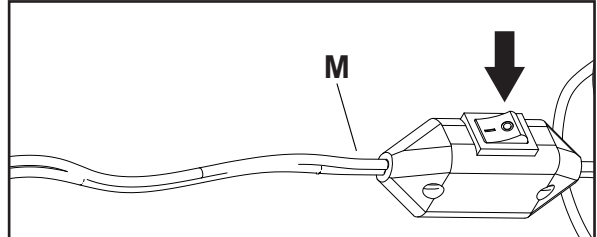

3. Pull the handle towards you and then push towards the center.
4. Guide the handle to rest on the adjustable stop (L).

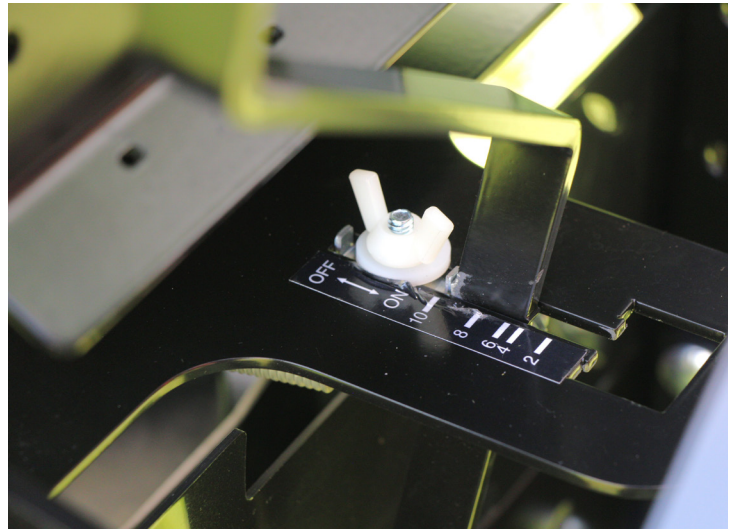

5. Start spreading your product.
6. When finished spreading pull handle and push to the left to set in the locking position.
7. Turn off the switch.

Maintenance

Servicing Spreader

When servicing is necessary, perform it in a protected area. Do not use power tools in rain or snow because of danger of electrical shock or injury. Keep area well lighted. Use proper tools. Keep the area of service clean to help avoid accidents.

Disconnect electricity to spreader before servicing.

Wash unit after each use to prevent material build-up and corrosion. Do NOT spray motor directly. Paint or oil all bare metal surfaces at the end of the season.

Removal and Storage

Removing Spreader From Tractor

1. Park the machine safely. (See Parking Safely in Safety section.)
2. Empty the spreader.
3. Lower tractor lift link to lowest position.
4. Disconnect the switch harness (M) from the 30" extension harness (C)
5. Remove the Cat. 1 Top Pin (V) and lynch pins (Z).
6. Remove the spreader for the 3 point arms.
7. Remove any added front ballast from machine.

SpeedEPart *the fastest way to purchase parts* www.speedepart.com

REPAIR PARTS

Agri-Fab, Inc.
809 South Hamilton
Sullivan, IL. 61951
217-728-8388
www.agri-fab.com

This document (or manual) is protected under the U.S. Copyright Laws and the copyright laws of foreign countries, pursuant to the Universal Copyright Convention and the Berne convention. No part of this document may be reproduced or transmitted in any form or by any means, electronic or mechanical, including photocopying or recording, or by any information storage or retrieval system, without the express written permission of Agri-Fab, Inc. Unauthorized uses and/or reproductions of this manual will subject such unauthorized user to civil and criminal penalties as provided by the United States Copyright Laws.