

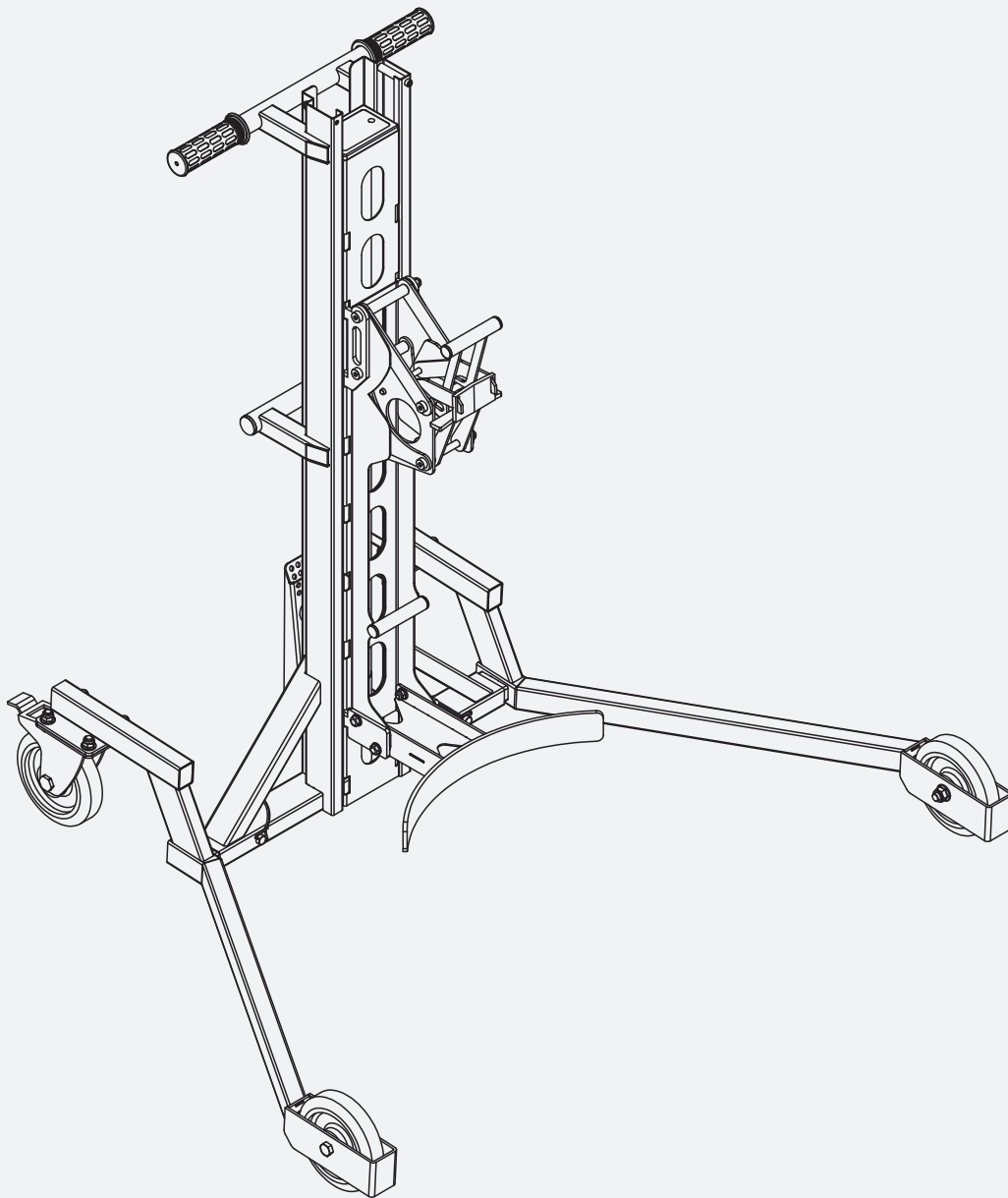

550 LB Drum Transfer Lift | GUO138 Operator's Manual



Warning: Please read and thoroughly understand all instructions before operating. Failure to follow safety rules and other basic safety precautions may result in serious personal injury. Keep these instructions in a safe and easily accessible place so that they can be referred to when needed. Retain these instructions to assist in future servicing.

INDEX

Warnings	3
Technical Specifications	4
Component Overview	5
Parts Overview	6
Assembly	7-9
Operation	10-13
Maintenance	14
Transportation and Storage	15
Warranty	15
Troubleshooting	16
Parts Explosion	17-18

Warnings

- Do not use or service this equipment until you have read and understood the operator's manual.
- Carefully read the "Installation and Operating Instructions" to understand the operation and procedures for the equipment.
- The maximum rated load for this equipment is 550 lb (250 kg). DO NOT overload.
- This equipment is designed for transporting drums that comply with ISO 15750-1 or plastic barrels that comply with ISO 20848-2.
- This equipment may only be used by designated personnel and inspectors. Maintenance and testing personnel should only use this equipment when necessary.
- Do not use this equipment if it is damaged, malfunctioning, or missing parts.
- Do not modify the product in any way. Unauthorized modifications will automatically void the limited warranty and may pose safety hazards.
- During use, do not place your feet or any other part of your body under the drum.
- Do not attempt to lift or transfer personnel with this equipment.
- When using this equipment to load and transport goods, ensure that the ground in the work area is level to avoid tipping or jolting that could cause the load to fall, resulting in damage to the goods or personal injury.
- Do not use in environments below 0°C, as the hydraulic system may not function properly.
- Ensure that all labels are in place and legible, do not use this equipment if they are not clear. Do not remove or obscure any labels.
- Inspect this equipment before each use, if maintenance is required, contact the supplier for replacement parts.
- Before leaving the equipment, the load must be lowered, and the brakes must be engaged to prevent the equipment and load from moving, which could cause damage or injury.
- Children should stay away from the operating area, and minors are not permitted to use this equipment.

Main Applications

Primarily designed for handling U.S. standard 55-gallon drums, this drum lift features a lightweight structure and is easy for a single person to operate. It is ideal for lifting, short-distance movement, and transportation of drums in warehouses, auto repair shops, and processing workshops.

Technical Specifications

SKU#	GU0138
Max. Lifting Weight	550 lb (250 kg)
Max. Lifting Height	31.5" (800 mm)
Hydraulic Cylinder Stroke	31.5" (800 mm)
Supported Drum Size	55 Gal. (208 L) Drum
Item Size	41.3"x53.1"x29.5" (1050x1350x750 mm)
Net Weight	95 lb (43 kg)

NOTE: The drum can be lifted to different heights, but the actual lifting height will be affected by the installation position of the hook.

Component Overview

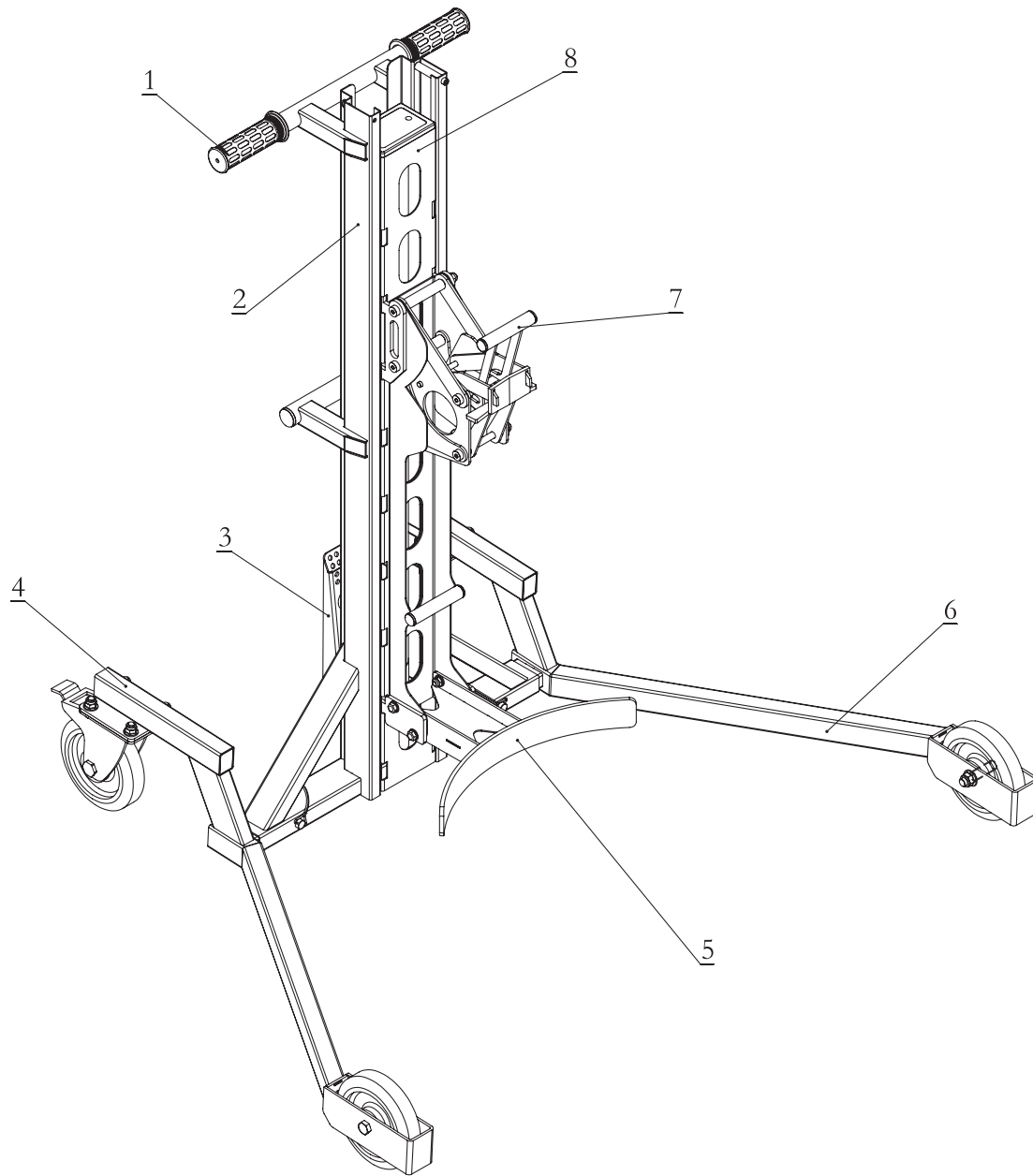

1. Transport Handle – Used to maneuver and guide the drum lift during transport and positioning.
2. Main Frame – The central structural support that connects all components and allows for vertical movement.
3. Hydraulic Foot Pump – Provides the lifting force needed to raise and lower the drum by applying hydraulic pressure.
4. Left Support Leg – Stabilizes the left side of the lift and houses a swivel caster for maneuverability.
5. Drum Saddle – Providing support during lifting and transport.
6. Right Support Leg – Stabilizes the right side of the lift and includes a fixed wheel for directional movement.
7. Drum Clamp Assembly – Secures the drum in place, preventing movement during lifting and transport.
8. Drum Support Frame – Connects to the main frame and holds the drum clamp assembly, allowing for controlled lifting and lowering.

Parts Overview

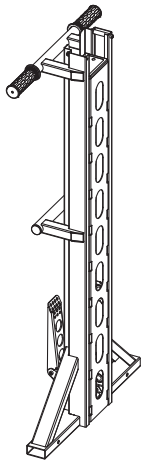

1. Main Frame

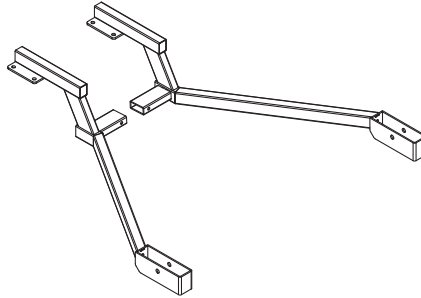

2. Left & Right Support Legs

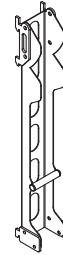

3. Drum Support Bracket

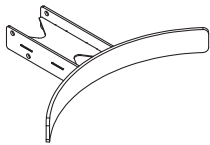

4. Drum Saddle

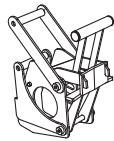

5. Drum Clamp

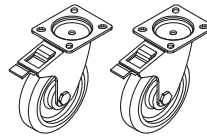

6. 6" Swivel Casters (x2)



7. 6" Fixed Wheels (x2)

Assembly Hardware



M10 Nut (x8)

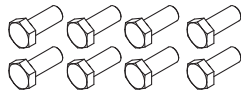

M10x25 Bolt (x8)

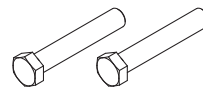

M12x70 Bolt (x2)

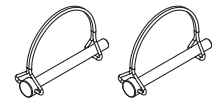

D-Pin (x2)

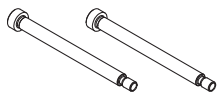

Pin Bolt (x2)

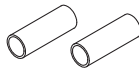

Axle Sleeve (x2)

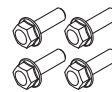

M8 x 25 Bolt (x4)



M8 Nut (x6)



M12 Nut (x2)

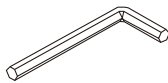

Allen Wrench (x1)

Assembly

Recommended Tools:

Adjustable Wrench



Step 1: Install the Fixed Wheels

1. Insert the axle sleeve into the wheel.
2. Position the wheel in the center of the support leg's wheel bracket.
3. Insert the M12×70 bolt from the outer side of the wheel bracket, passing through both the bracket and the wheel.
4. Secure the bolt on the other side with an M12 nut.
5. Repeat for the other wheel. **(Fig. 01)**

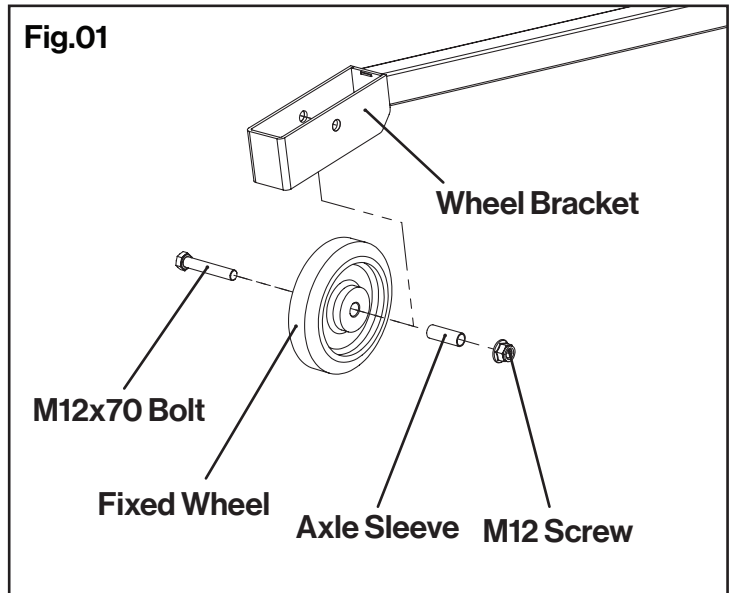

Step 2: Install the Swivel Casters

1. Insert four M8×25 bolts from underneath the swivel caster plate.
2. Position the caster on top of the wheel support bracket.
3. Secure the bolts using M8 nuts.
4. Repeat for both left and right swivel casters. **(Fig. 02)**

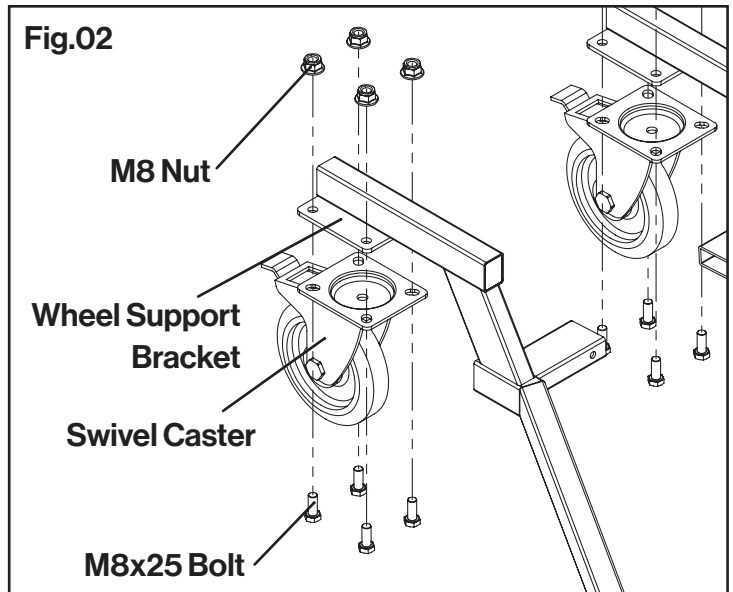

Step 3: Attach the Support Legs

1. Align the support leg with the main frame and insert it into the designated mounting slot.
2. Secure the support leg by inserting the D-pin through the alignment hole.
3. Ensure the D-pin is fully engaged, then repeat the process for the other support leg. **(Fig. 03)**

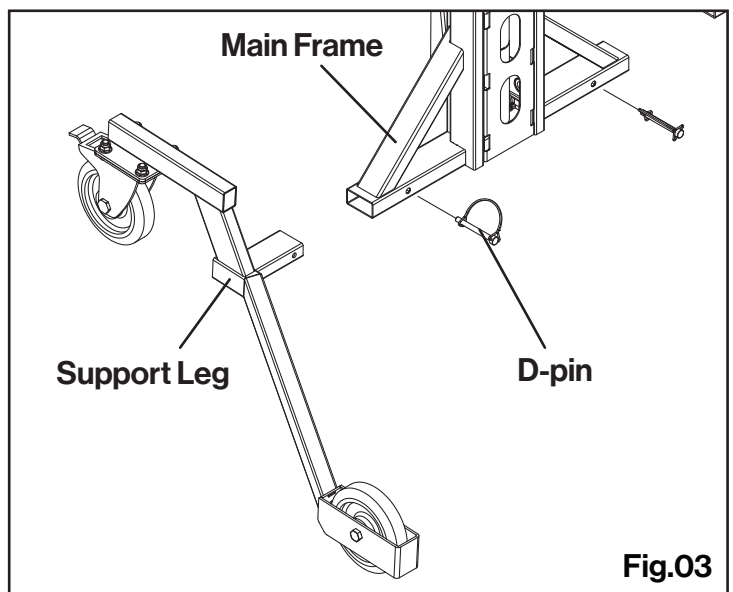

Step 4: Attach the Drum Clamp Assembly

1. Align Pin Bolt A and Pin Bolt B on the Drum Clamp Assembly with the corresponding holes on the Drum Support Bracket.
2. Insert the Pin Bolt through the holes, ensuring they pass through the Drum Clamp Assembly and the Drum Support Frame.
3. Secure the bolts using M8 Nuts. **(Fig. 04)**
4. After installation, pull the Locking Handle to ensure the Drum Clamp Assembly moves smoothly. **(Fig. 05)**

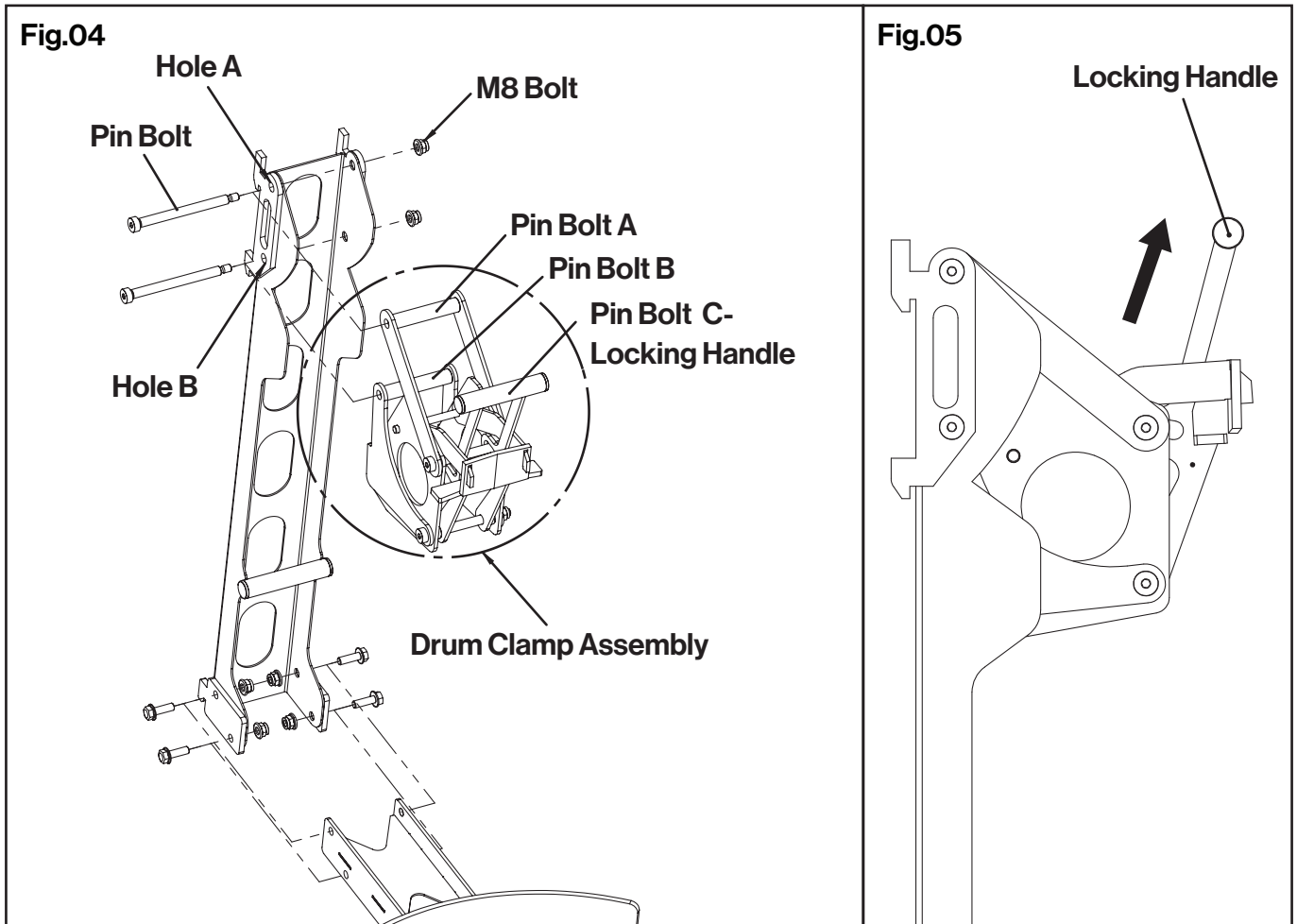

Step 5: Assemble the Drum Saddle

1. Align the drum saddle with the mounting holes at the bottom of the drum support frame.
2. Secure the drum saddle in place using four M8 × 25 bolts and four M8 nuts. **(Fig. 06)**

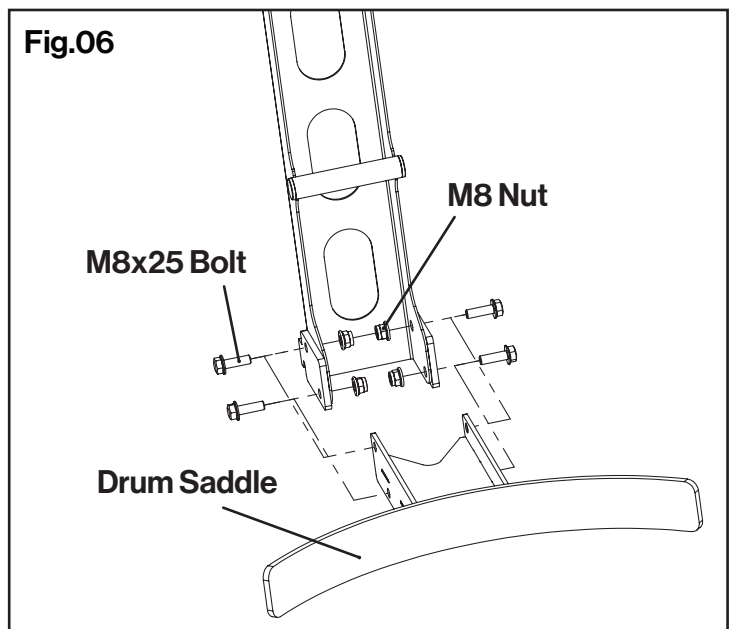

Step 6: Attach the Drum Clamp Assembly

1. Place the primary frame on a stable surface and lock the swivel casters.
2. Align the upper mount of the drum support frame with the corresponding hole on the primary frame, ensuring both sides enter simultaneously.
3. Keep the lower mount positioned inside the hole, then adjust the drum support frame until the upper bracket and lower bracket align properly.
4. Release the locking handle, allowing the drum clamp assembly to lock in place.
5. Confirm that the drum clamp assembly is installed correctly. **(Fig. 07)**

Fig.07

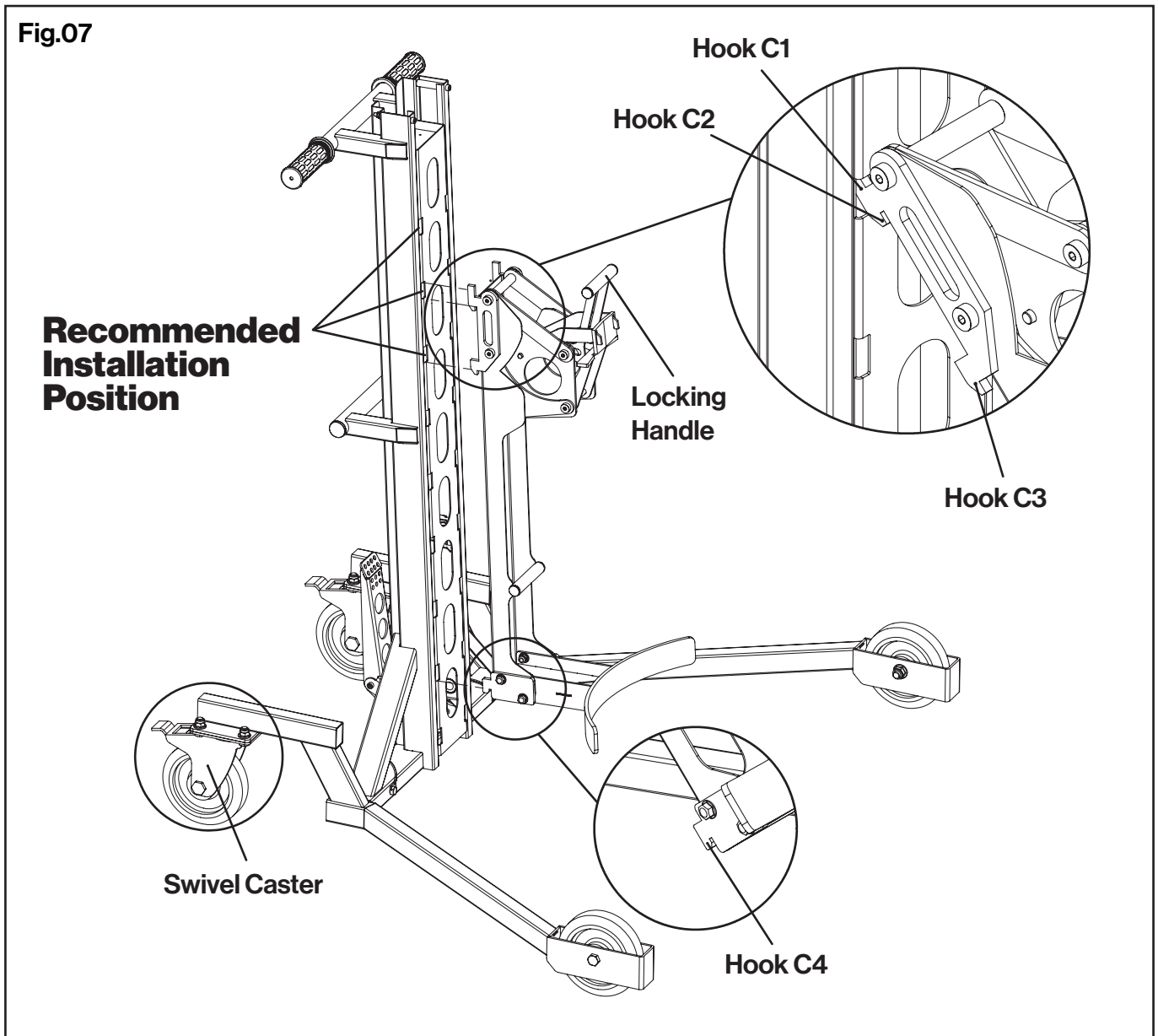

Operation

NOTICE:

1. Ensure all bolts are tightened before use.
2. Inspect the tires for cracks or delamination.
3. Perform a test run without a load to check for smooth operation.
4. Do not exceed the maximum load capacity of 550 lb (250 kg).
5. Avoid operating or parking on slopes.
6. Verify that the drum support frame is properly installed (**Fig. 07**) and securely connected to the main frame to prevent the drum from falling during movement, which could result in damage or injury.

Preparation Before Operation

Push the equipment close to the drum and adjust to the appropriate lifting position for the drum through the lifting/lowering operation.

Firmly hold the transport handle with both hands and press the foot pedal to begin operation. (**Fig. 08**)

Lifting the Equipment

Press down on the pedal to raise the drum support frame. (**Fig.09**)

Lowering the Equipment

Press the pedal fully and hold it to slowly lower the drum support frame. (**Fig. 10**)

Note: The pedal's position above the horizontal level indicates lifting. Pressing the pedal below the horizontal position initiates lowering.

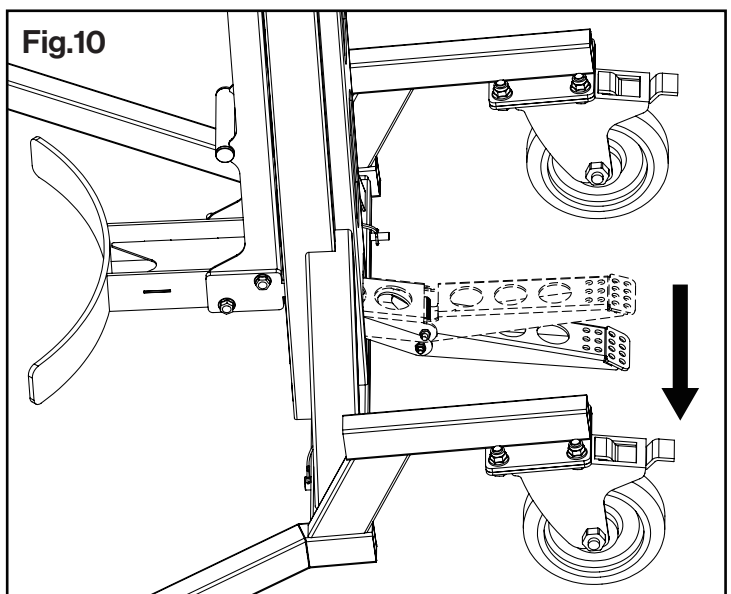
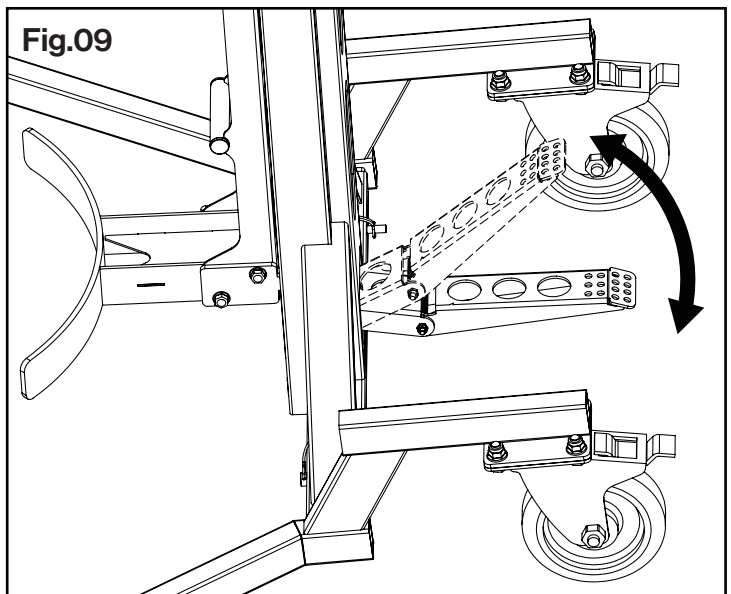
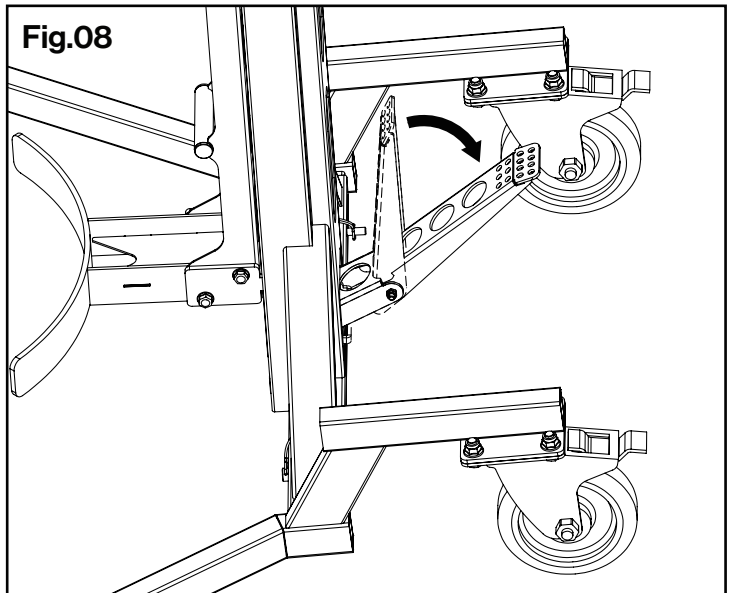

Clamping the Drum

1. Move the drum cradle close to the drum. **(Fig. 11)**
2. Adjust the pedal to raise the drum clamp to a suitable height.

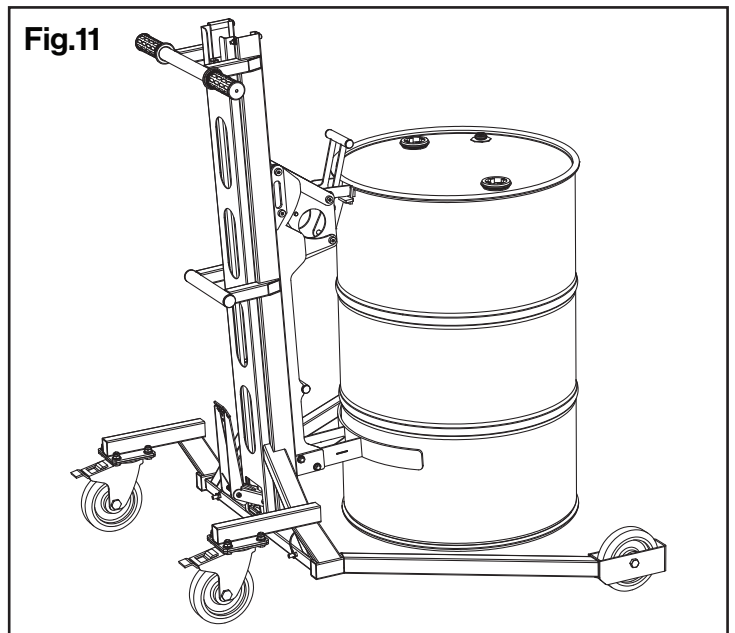

3. Position the clamp support plate approximately 0.8 inches below the top edge of the drum. **(Fig. 12)**

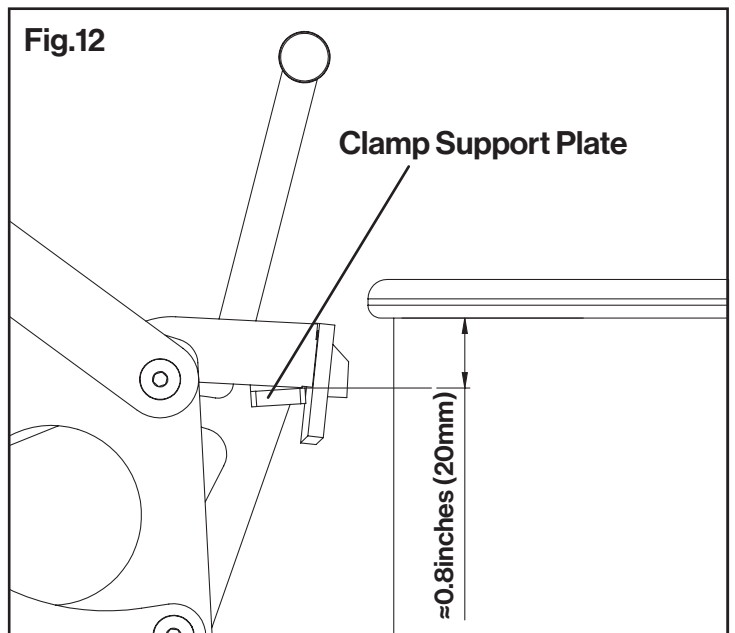

Operating the Drum Clamp

1. Raise the handle and bring the clamp close to the drum edge. **(Fig. 13)**

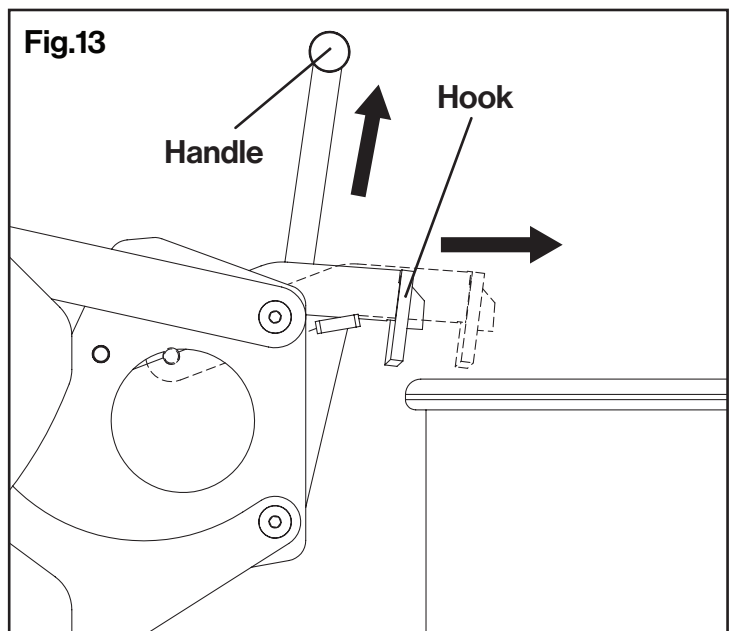

2. Release the handle to allow the clamp to latch onto the inside edge of the drum. **(Fig. 14)**

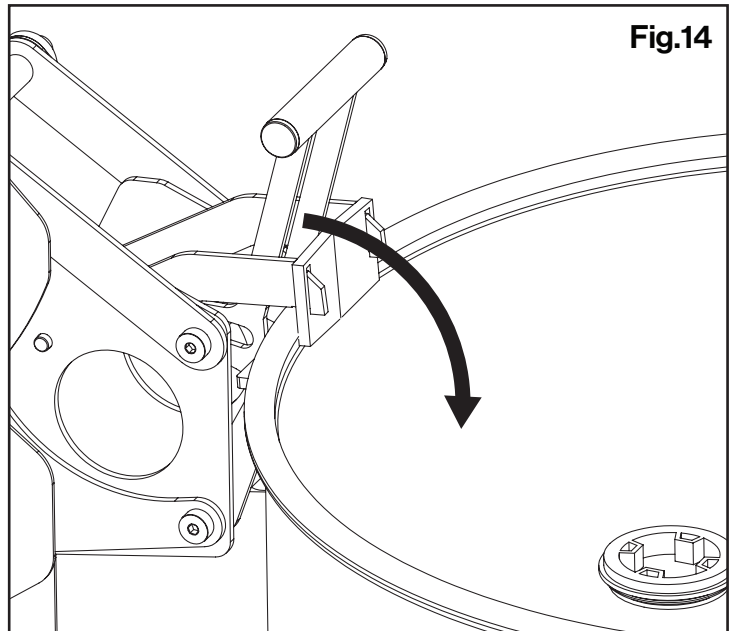

Fig.14

3. Ensure the clamp support plate rests below the drum edge. **(Fig. 15)**

Note: If the clamp height does not align with the drum, readjust its position. (Refer to Assembly Step 6.)

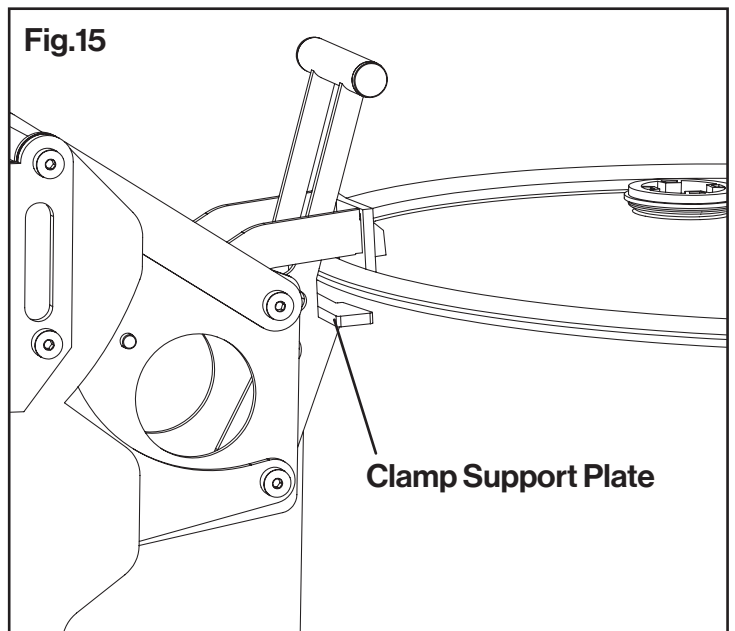

Fig.15

Clamp Support Plate

⚠ WARNING

Ensure the clamp is fully locked onto the drum edge to prevent slipping. (Fig. 16)

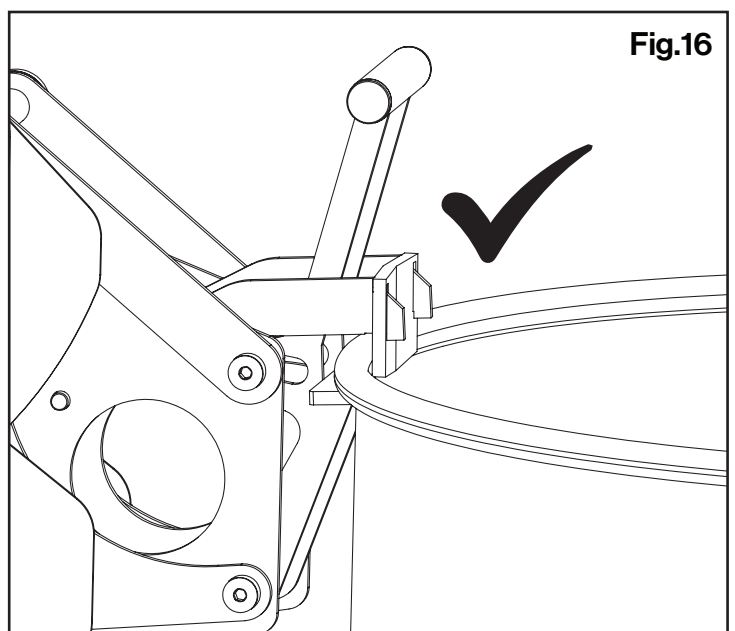
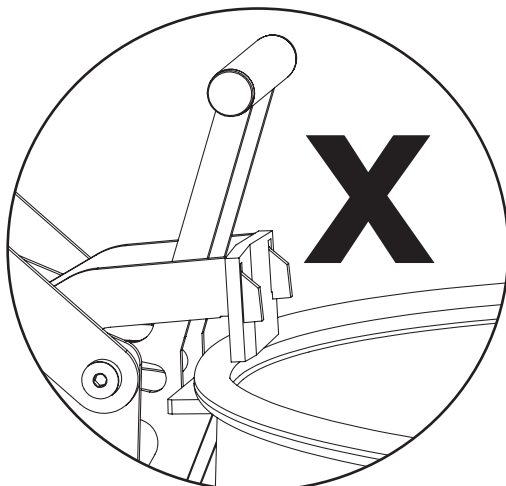

Fig.16

Lifting the Drum

When lifting a loaded drum, the pedal will require firm downward pressure at the start. Control the force and extent of the press to ensure smooth lifting.

Transporting the Drum

Hold the handle with both hands and push the drum lift to the unloading position.

Note: This equipment is designed for use on flat surfaces. Uneven or bumpy surfaces may cause the drum to fall, leading to equipment damage or injury.

Unloading the Drum

Move the drum to the unloading position, controlling the pedal until the drum is fully lowered. Lift the clamp handle to release the drum, allowing the lift to move away.

Note: If the handle cannot be lifted, press the pedal down fully again and wait for the drum support frame to descend until the clamp is fully released. (Fig. 17) & (Fig. 18)

Operating the Swivel Caster

To move the drum lift, press the unlock pedal to enable wheel movement. During storage or non-use, press the lock pedal to prevent the lift from shifting unintentionally. **(Fig. 19)**

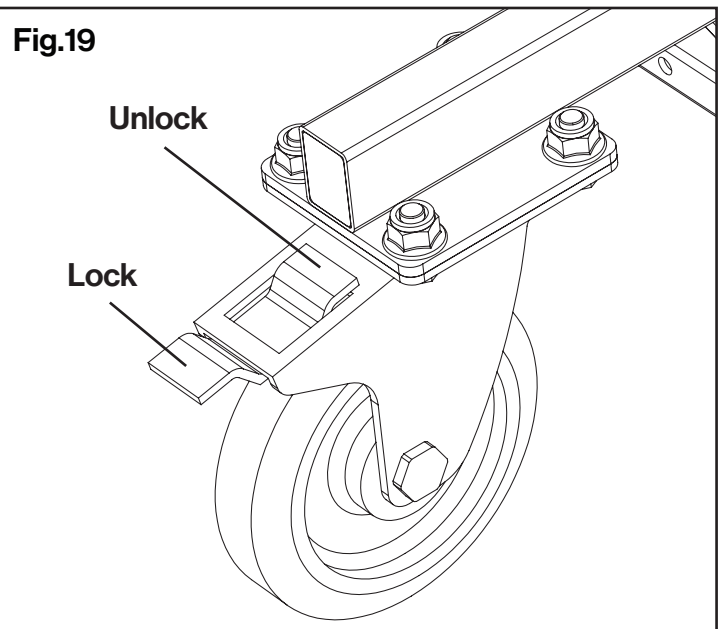
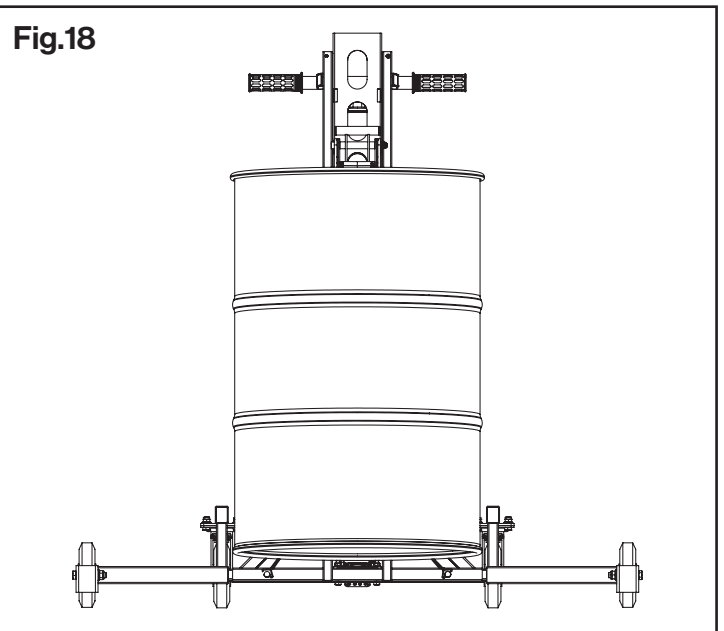
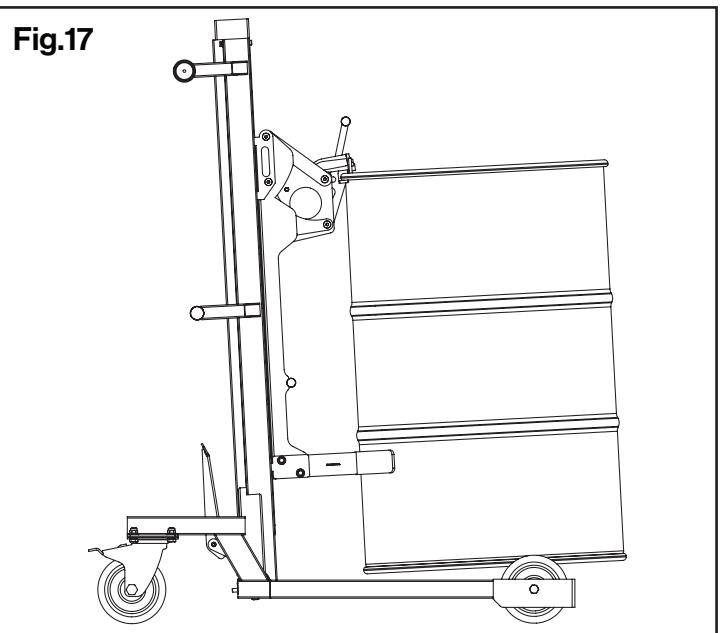

Maintenance

Fixed Wheels Replacement and Cleaning

Regularly inspect the wheels for wear. Clean them as needed or refer to installation step 1 for replacement. **(Fig. 20)**

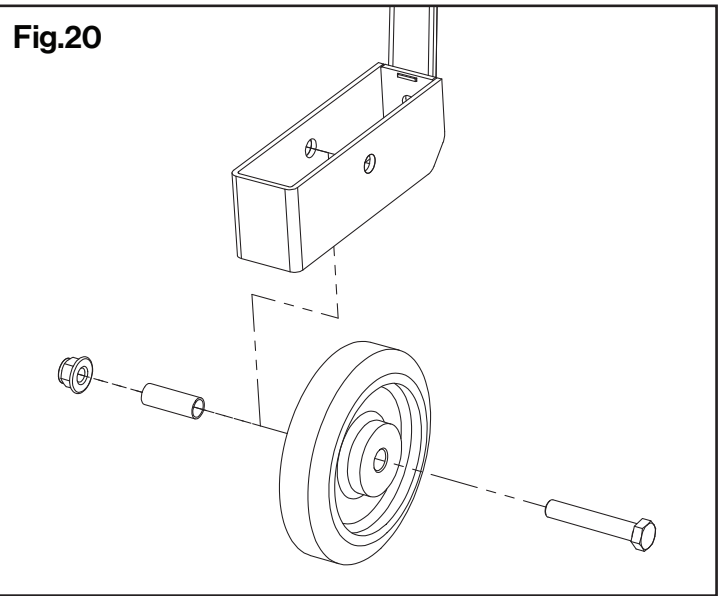

Swivel Casters Replacement

Refer to installation step 2 to replace the swivel casters. **(Fig. 21)**

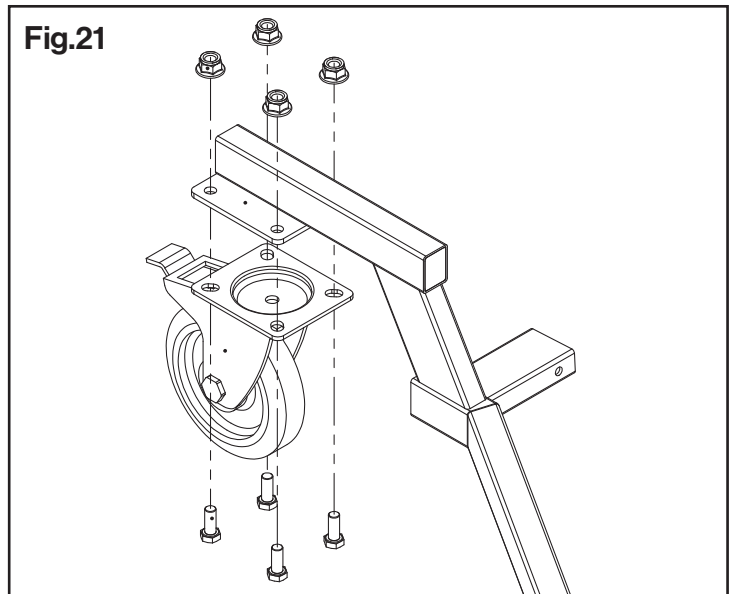

Transportation and Storage

Secure the drum lift properly during transport to prevent movement or tipping.

Use appropriate straps or chains to fasten the lift to the transport vehicle.

Regularly inspect and maintain hydraulic components, especially before and after transportation.

Store the drum lift in a temperature-controlled environment to prevent freezing of hydraulic fluid or overheating, which may affect system performance.

Keep the lift in a dry location away from direct sunlight to prevent UV damage.

Warranty

This product includes a twelve (12) month warranty covering workmanship, excluding normal wear and tear. The warranty period begins on the purchase date and applies only to material defects and workmanship issues. It does not cover damage caused by improper use or modifications. Any tampering or operation outside the specifications of this manual will void the warranty.

Troubleshooting

Issue	Possible Cause	Solution
<p>Pedal down, drum support bracket cannot rise.</p>	<ol style="list-style-type: none"> 1. Excessive downward pressure on the pedal. 2. Foreign objects obstructing the slide rails. 	<ol style="list-style-type: none"> 1. Adjust pedal operation. 2. Remove foreign objects from the slide rails.
<p>Pedal fully depressed, drum support bracket cannot descend, or descent speed is slow.</p>	<ol style="list-style-type: none"> 1. Drum clamp not installed correctly, causing an imbalance. 2. Low environmental temperature affecting cylinder function. 3. Cylinder damage. 4. Foreign objects on the slide rails. 	<ol style="list-style-type: none"> 1. Ensure the drum support frame is installed correctly. 2. Avoid using in temperatures below 0°C. 3. Replace the cylinder if necessary. 4. Remove foreign objects from the slide rails.
<p>Equipment moves unsteadily or makes unusual noises.</p>	<ol style="list-style-type: none"> 1. Damaged swivel wheels. 2. Foreign objects obstructing wheel movement. 	<ol style="list-style-type: none"> 1. Replace the swivel wheels. 2. Remove foreign objects.

Parts Explosion

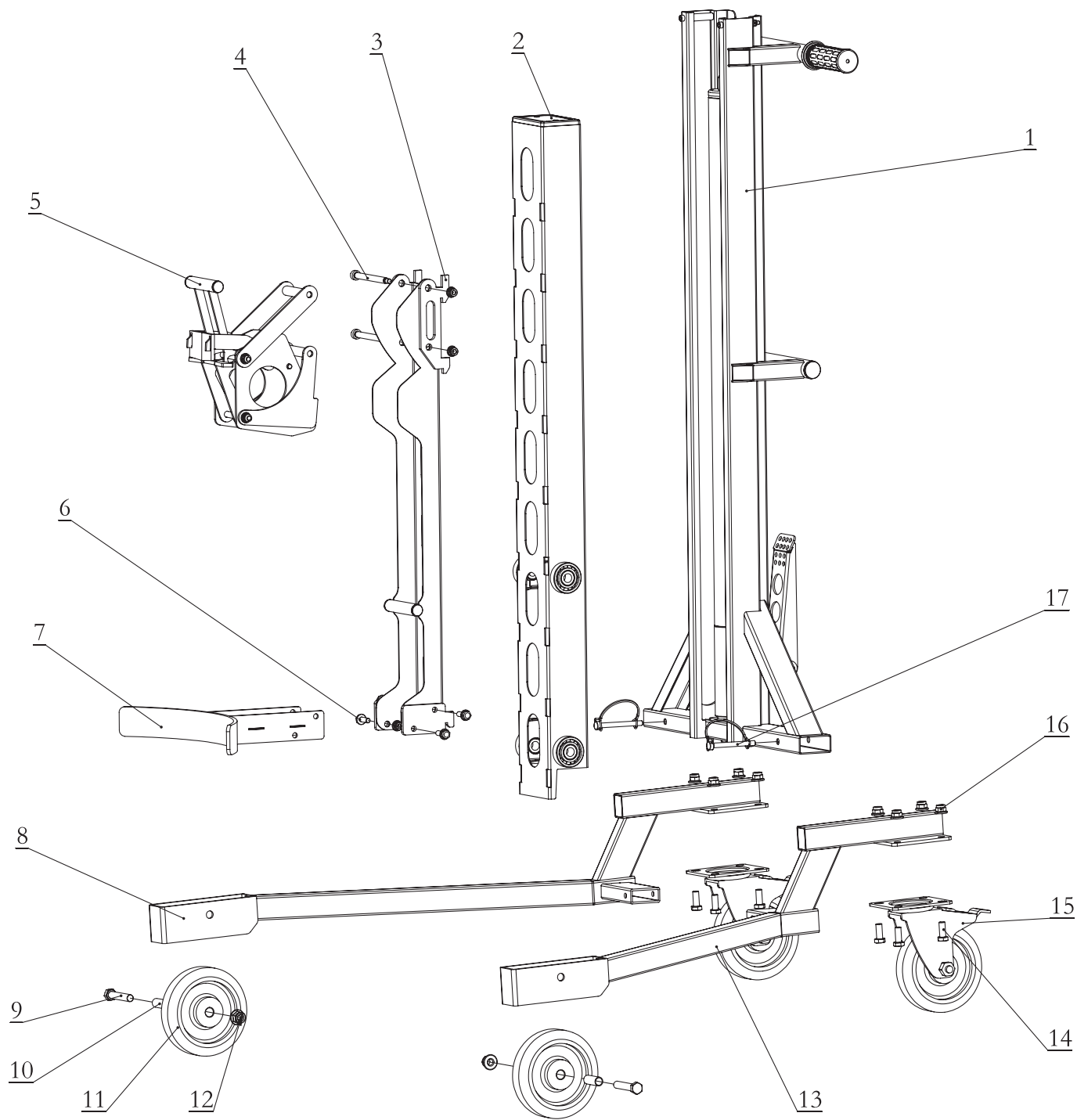

Part No.	Description	Q'ty	Part No.	Description	Q'ty
1	Main Frame	1	10	Axle Sleeve	2
2	Drum Support Frame	1	11	Fixed Wheel	2
3	Drum Support Bracket	1	12	M8 Nut	6
4	Φ10-M8 Pin Bolt	2	13	Right Support Leg	1
5	Drum Clamp Assembly	1	14	M10x25 Bolt	8
6	M8x25 Screw	4	15	Swivel Caster	2
7	M12x70 Bolt	1	16	M10 Nut	8
8	Left Support Leg	1	17	D-pin	2
9	M12x70 Bolt	2			



Thank you for supporting our brand!

superhandyus.com



Great Circle USA
Support Line: 1-866-493-0524
help@greatcircleus.com
www.superhandyus.com



Follow us on social media
@SuperHandy