

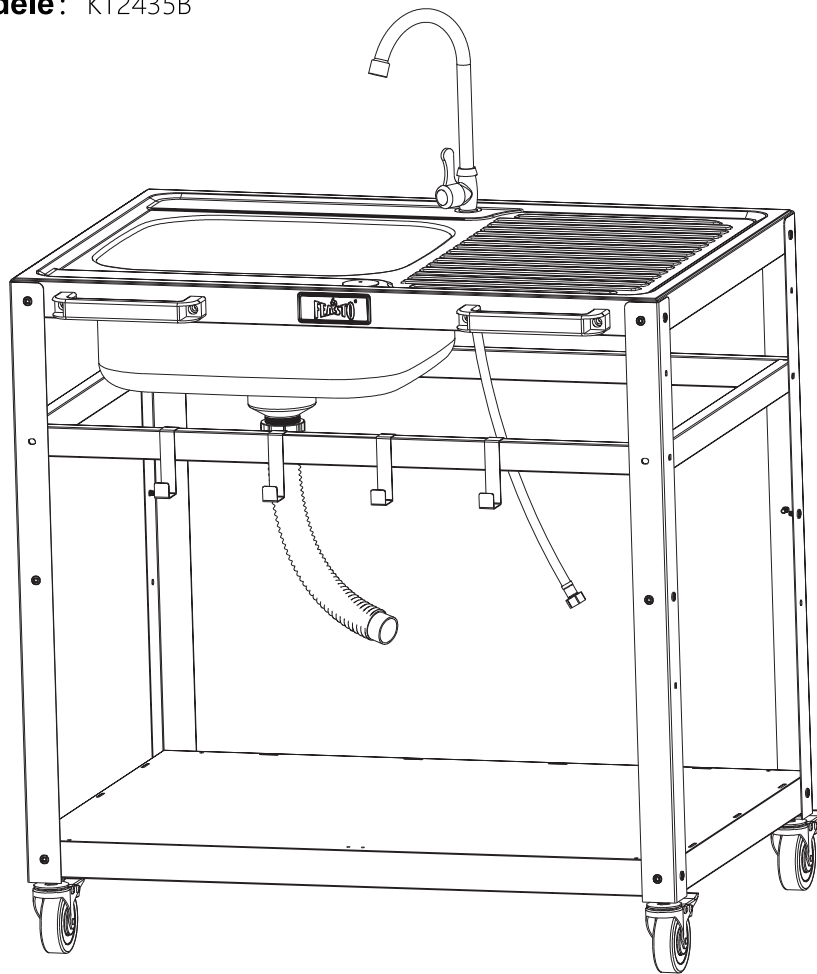

OWNER'S MANUAL MANUAL DEL USUARIO MANUEL DE L'UTILISATEUR

OUTDOOR MOBILE KITCHEN ISLAND CART WITH SINK COCINA MÓVIL PARA EXTERIOR CARRO ISLA CON FREGADERO CHARIOT ÎLOT DE CUISINE MOBILE EXTÉRIEUR AVEC ÉVIER

Model | Modelo | Modèle: KT2435B



Read these instructions carefully and retain them for future use.

Lea atentamente estas instrucciones y guárdelas para usarlas más adelante.

Veuillez lire attentivement les présentes instructions et les conserver afin de pouvoir vous y référer ultérieurement.

Customer Service / Servicio al Cliente / Service de Clientèle

 1-470-589-8732

 service@feastooutdoors.com

www.feastooutdoors.com

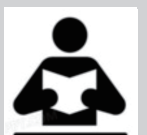

READ MANUAL BEFORE USE

TABLE OF CONTENTS

Important Safeguards	1
Cleaning and Maintenance	1
Parts Diagram	4
Preparation	5
Parts and Hardware List	6
Assembly	7-13
Limited Warranty	14

IMPORTANT SAFEGUARDS

When using the product, basic safety precautions should always be followed to reduce the risk of injury including the following:

Risk of injury!

Product can tip over. Do not let children climb on or play with the product.

- Keep children and pets away while assembling the product.
- Always use the product on a firm, level ground.
- Do not use this product if any parts are missing, damaged, or worn.
- To avoid scratching the floor, assemble the product on a soft surface, such as a carpet.
- Regularly examine the product for wear and tear. Stop using the product at first sign of damage or if parts become detached.
- Do not overload the product. Load the product evenly and place the heaviest items on the bottom shelf.

Cleaning and Maintenance

Cleaning

- To clean the product, wipe with a soft, slightly moist cloth.
- Never use corrosive detergents, wire brushes, abrasive scourers, metal or sharp utensils to clean the product.

Maintenance

- Regularly check that all the components and fasteners are tightened.
- Store the product in a cool and dry place away from children and pets, ideally in its original packaging.
- Avoid any vibrations and shocks.



CALIFORNIA PROPOSITION 65 WARNING

This product contains Nickel (Metallic) known to the State of California to cause cancer.

For more information, go to: www.P65Warnings.ca.gov

Wash your hands after handling this product.



Risk of suffocation!

- Keep any packaging materials away from children-these materials are a potential source of danger, e.g.suffocation.
- Remove all the packing materials.

Before beginning assembly, make sure all parts are present. If any parts are missing or damaged, do not attempt to assemble the products. Contact customer service for replacement parts via telephone or email.

ÍNDICE DE MATERIAS

Consideraciones de seguridad importantes	2
Limpieza y Mantenimiento	2
Diagrama de partes	4
Preparación	5
Lista de piezas y hardware	6
Montaje	7-13
Garantía limitada	14

CONSIDERACIONES DE SEGURIDAD IMPORTANTES

Al usar el producto, y para reducir el riesgo de lesiones, se deben seguir siempre las precauciones de seguridad básicas, incluidas las siguientes:

¡Riesgo de lesiones!

El producto puede volcarse. No permita que los niños trepen en o jueguen con el producto.

- Cuando arme el producto, mantenga a los niños y mascotas alejados.
- Use siempre el producto sobre un terreno firme y nivelado.
- No use el producto si alguna de las piezas está dañada, ausente o gastada.
- Para evitar raspar el piso, arme el producto sobre una superficie suave como una alfombra.
- Revise el producto regularmente y asegúrese de que no tenga desgaste ni daños. Deje de usar el producto a la primera señal de daños o si las piezas se desconectan.
- No sobrecargue el producto. Cargue el producto de manera uniforme y coloque los artículos más pesados en el estante inferior.

Limpieza y Mantenimiento

Limpieza

- Para limpiar el producto, use un paño suave y levemente humedecido.
- Jamás use detergentes corrosivos, cepillos de alambre, escobillas abrasivas, ni utensilios metálicos o afilados para limpiar el producto.

Mantenimiento

- Verifique con regularidad que todos los componentes y sujeciones estén firmes.
- Almacene el producto en un lugar fresco y seco, alejado de niños y mascotas, idealmente en su empaque original.
- Evite vibraciones y golpes.

ADVERTENCIA DE LA PROPUESTA 65 DE CALIFORNIA

Este producto contiene Níquel (Metálico) conocido en el Estado de California como causante de cáncer.

Para más información, visite: www.P65Warnings.ca.gov

Lávese las manos después de manipular este.

¡Riesgo de asfixia!

- Mantenga los materiales de empaque lejos de los niños, ya que estos materiales son una posible fuente de peligro (asfixia).
- Saque todos los materiales del empaque.

Antes de comenzar el montaje, asegúrese de que todas las piezas estén presentes. Si falta alguna pieza o está dañada, no intente ensamblar los productos. Póngase en contacto con el servicio de atención al cliente para obtener piezas de repuesto por teléfono o correo electrónico.

TABLE DES MATIÈRES

Mesures de sécurité importantes	3
Nettoyage et Entretien	3
Schéma des pièces	4
Instructions d'assemblage	5
Liste des pièces et du matériel	6
Assemblage	7-13
Garantie limitée	14

MESURES DE SÉCURITÉ IMPORTANTES

Lors de l'utilisation du produit, certaines mesures de sécurité élémentaires doivent toujours être respectées afin de réduire tout risque de blessures, notamment les suivantes:

Risque de blessures!

Risque de basculement du produit. Ne pas laisser des enfants escalader le produit ni jouer avec celui-ci.

- Maintenez les enfants et les animaux domestiques à l'écart lors du montage du produit.
- Utilisez toujours le produit sur un sol ferme et nivelé.
- Ne pas utiliser ce produit en cas de composants manquants, endommagés ou usés.
- Afin d'éviter des rayures sur le plancher, montez le produit sur une surface molle telle qu'un tapis.
- Procédez régulièrement à un examen du produit afin de déceler toute usure éventuelle. Arrêtez d'utiliser le produit dès les premiers signes d'endommagement ou si des pièces s'en détachent.
- Ne surchargez pas le produit. Chargez le produit uniformément et placez les articles les plus lourds sur l'étagère du bas.

Nettoyage et Entretien

Nettoyage

- Pour nettoyer le produit, essuyez-le à l'aide d'un chiffon doux légèrement humide.
- Ne jamais utiliser de détergents corrosifs, de brosses métalliques, de tampons à récurer abrasifs, d'ustensiles métalliques ou coupants pour nettoyer le produit.

Entretien

- Assurez-vous régulièrement que tous les composants et toutes les fixations sont solidement fixés.
- Rangez le produit dans un endroit frais et sec hors de portée des enfants et des animaux familiers, idéalement dans son emballage d'origine.
- Évitez toutes vibrations et tous chocs.

AVERTISSEMENT 65 RELATIF À LA PROPOSITION

Ce produit contient du Nickel (Métallique) reconnu par l'État de Californie comme la source de cancer.
Pour plus d'informations, visitez: www.P65Warnings.ca.gov

Veuillez vous laver les mains après avoir manipulé ce produit.

Risque d'étouffement!

- Conservez tous les matériaux d'emballage hors de la portée des enfants: ces matériaux constituent une source de danger potentiel, p.ex. étouffement.
- Retirez-en tous les matériaux d'emballage.

Avant de commencer l'assemblage, assurez-vous que toutes les pièces sont présentes. Si des pièces sont manquantes ou endommagées, n'essayez pas d'assembler les produits. Contactez le service de clientèle pour les pièces de rechange par téléphone ou par e-mail.

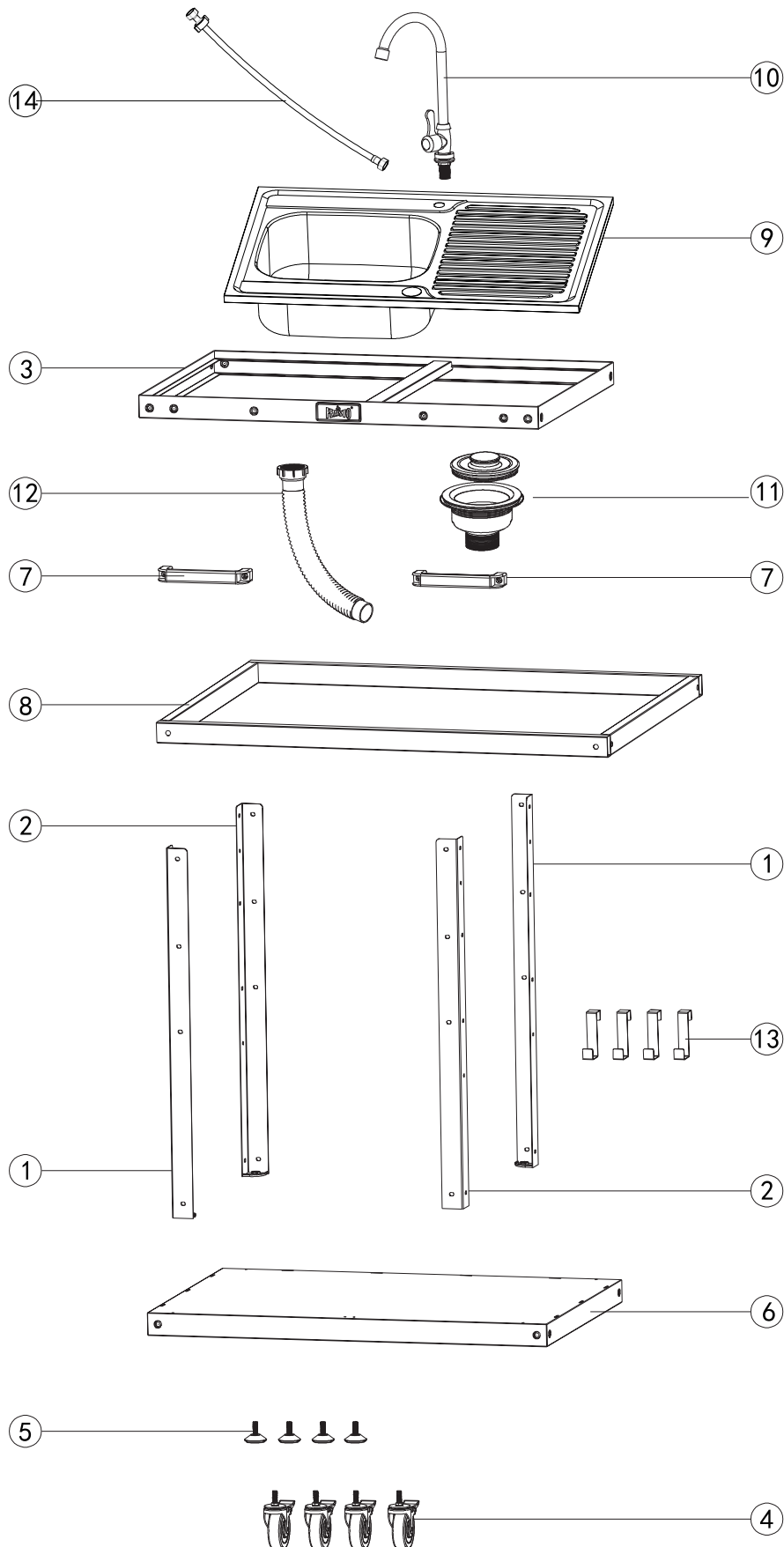



TOOLS REQUIRED
HERRAMIENTAS REQUERIDAS
OUTILS REQUIS

Description / Descripción / Description

Hex screwdriver
Destornillador hexagonal
Tournevis hexagonal



Wrench
Llave
Clé



- Tools needed: Hex screwdriver, wrench (not included)
Herramienta necesaria: Destornillador hexagonal, llave (no incluido)
Outils nécessaires: Tournevis hexagonal, clé (non inclus)
 - Approximate assembly time: 25 minutes
Tiempo aproximado de ensamblaje: 25 minutos
Temps nécessaire pour l'assemblage: 25 minutes
-

Notice:











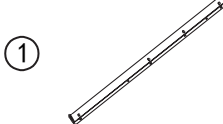

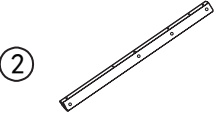













1. Follow the installation instructions.
Please confirm all accessories are present before installation.
2. Do not fully tighten the screws during initial assembly. Fully tighten screws only once all pieces which are correctly assembled.
3. If you encounter any problems during installation, contact our customer service.

Aviso:

1. Siga las instrucciones de instalación. Confirme que todos los accesorios estén presentes antes de la instalación.
2. No apriete completamente los tornillos durante el ensamblaje inicial. Apriete completamente los tornillos solo una vez que todas las piezas estén correctamente ensambladas.
3. Si encuentra algún problema durante la instalación, comuníquese con nuestro servicio al cliente.

Remarquer:

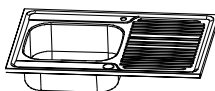
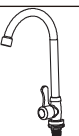
1. Suivez les instructions d'installation. Veuillez confirmer que tous les accessoires sont présents avant l'installation.
 2. Ne serrez pas complètement les vis lors de l'assemblage initial. Ne serrez complètement les vis qu'une fois toutes les pièces correctement assemblées.
 3. Si vous rencontrez des problèmes lors de l'installation, contactez notre service client.
-

No.	Image / Imagen / l' image	QTY / CANT. / QTÉ	No.	Image / Imagen / l' image	QTY / CANT. / QTÉ																		
1		2	13		4																		
2		2	14		1																		
3		1	<p>Hardware List / Lista de hardware / Liste du matériel</p> <table border="1"> <thead> <tr> <th>No.</th> <th>Image / Imagen / l' image</th> <th>QTY / CANT. / QTÉ</th> </tr> </thead> <tbody> <tr> <td>A</td> <td>M6x12 </td> <td>33</td> </tr> <tr> <td>B</td> <td>M6x15 </td> <td>5</td> </tr> <tr> <td>C</td> <td></td> <td>4</td> </tr> <tr> <td>D</td> <td></td> <td>4</td> </tr> <tr> <td>A1</td> <td></td> <td>1</td> </tr> </tbody> </table>			No.	Image / Imagen / l' image	QTY / CANT. / QTÉ	A	M6x12 	33	B	M6x15 	5	C		4	D		4	A1		1
No.	Image / Imagen / l' image	QTY / CANT. / QTÉ																					
A	M6x12 	33																					
B	M6x15 	5																					
C		4																					
D		4																					
A1		1																					
4		4																					
5		4																					
6		1																					
7		2																					
8		1																					
9		1																					
10		1																					
11		1																					
12		1																					

1

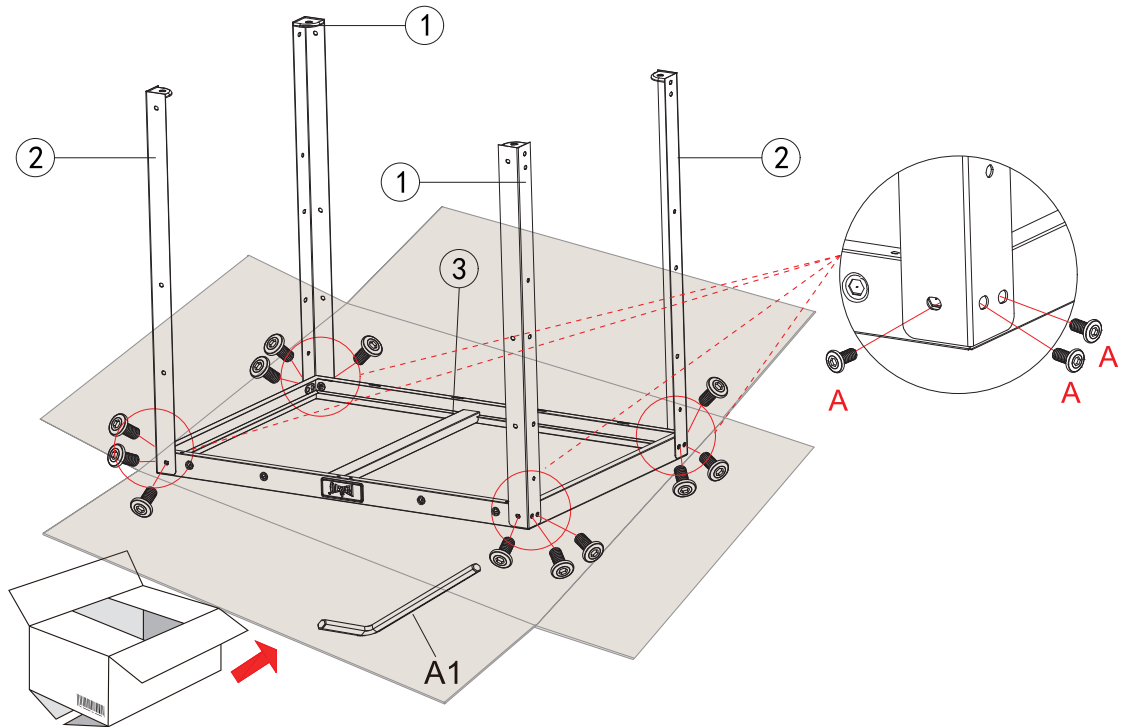
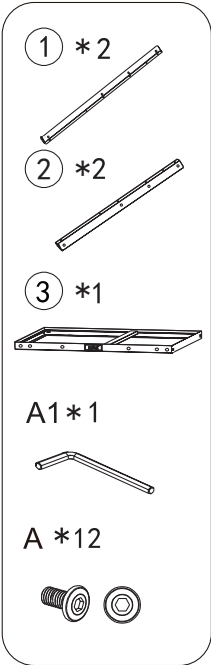

2

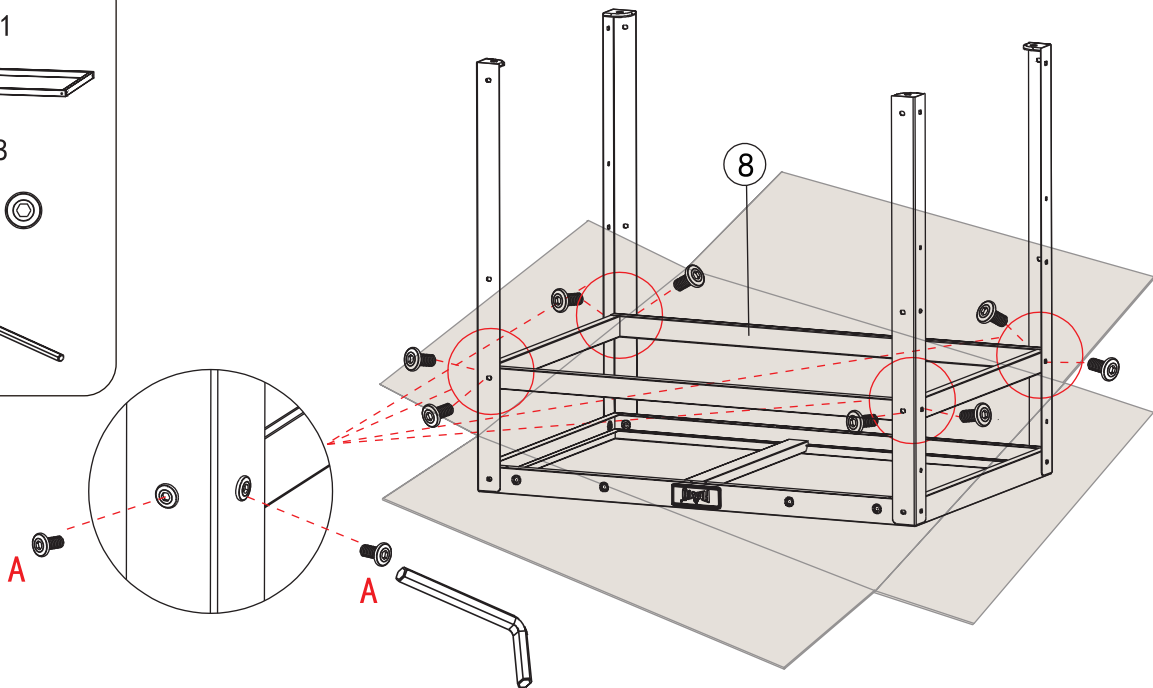
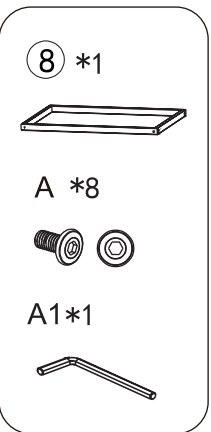

3

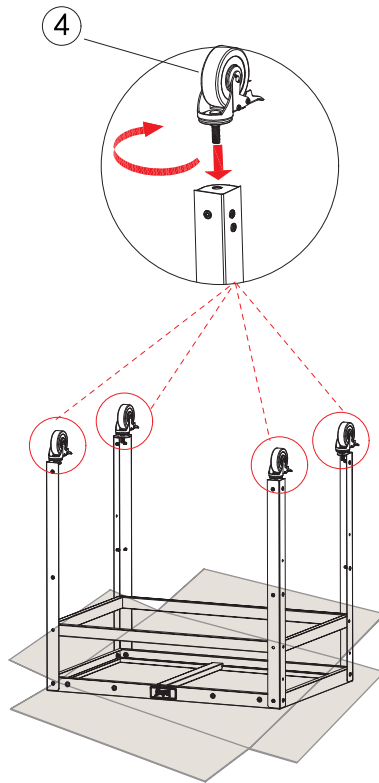
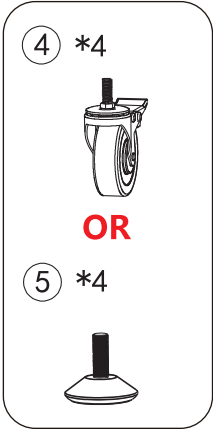

OR

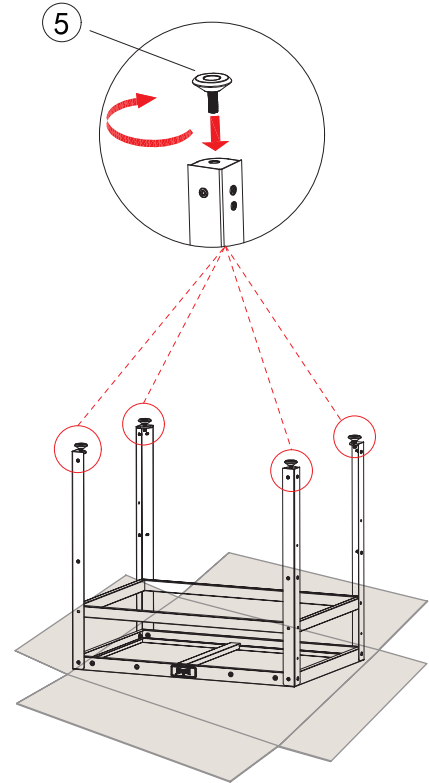

4

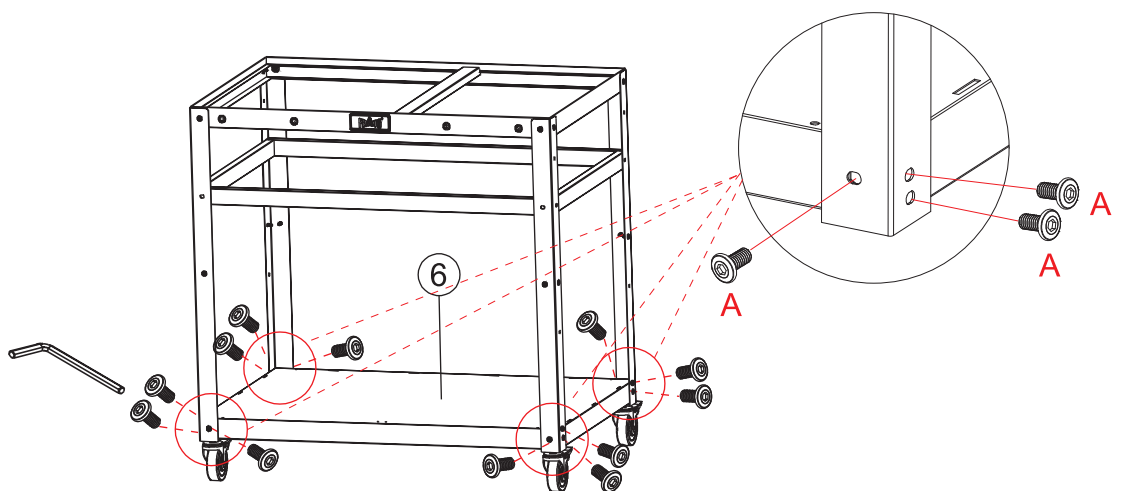
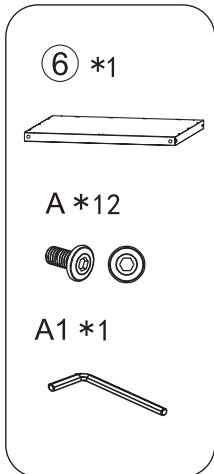

5

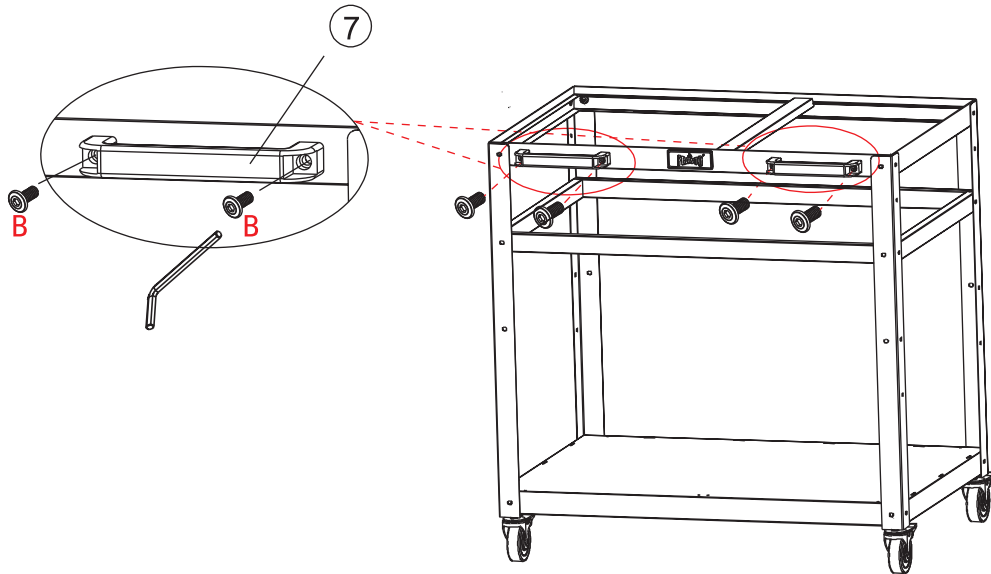
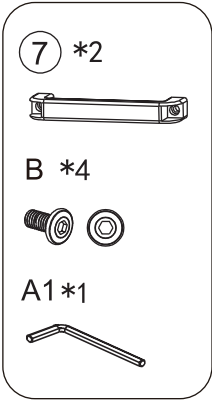

6

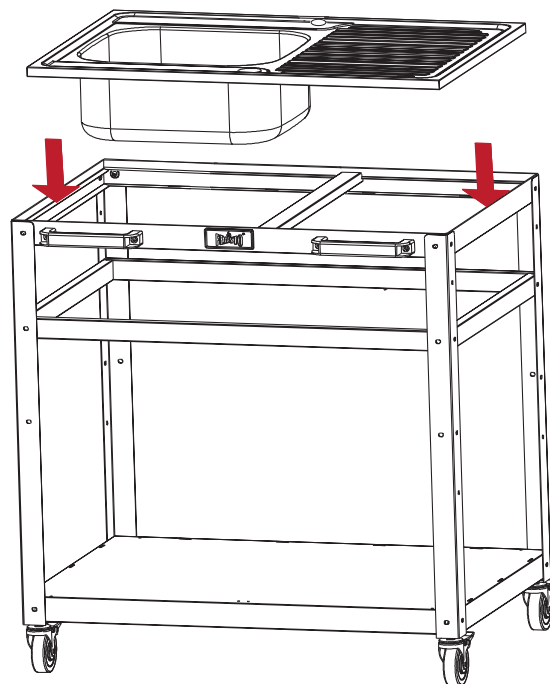
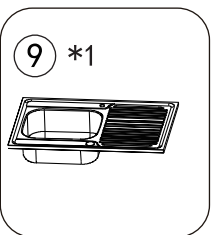

7

Install the faucet assembly (10) into the counter top assembly (9) by inserting the faucet, S/S cover and thick rubber in from the top then securing from the bottom with the small rubber washer and plastic nut. Complete by screwing the small end (3/8") of supply hose (14) onto the bottom of the faucet and tightening.

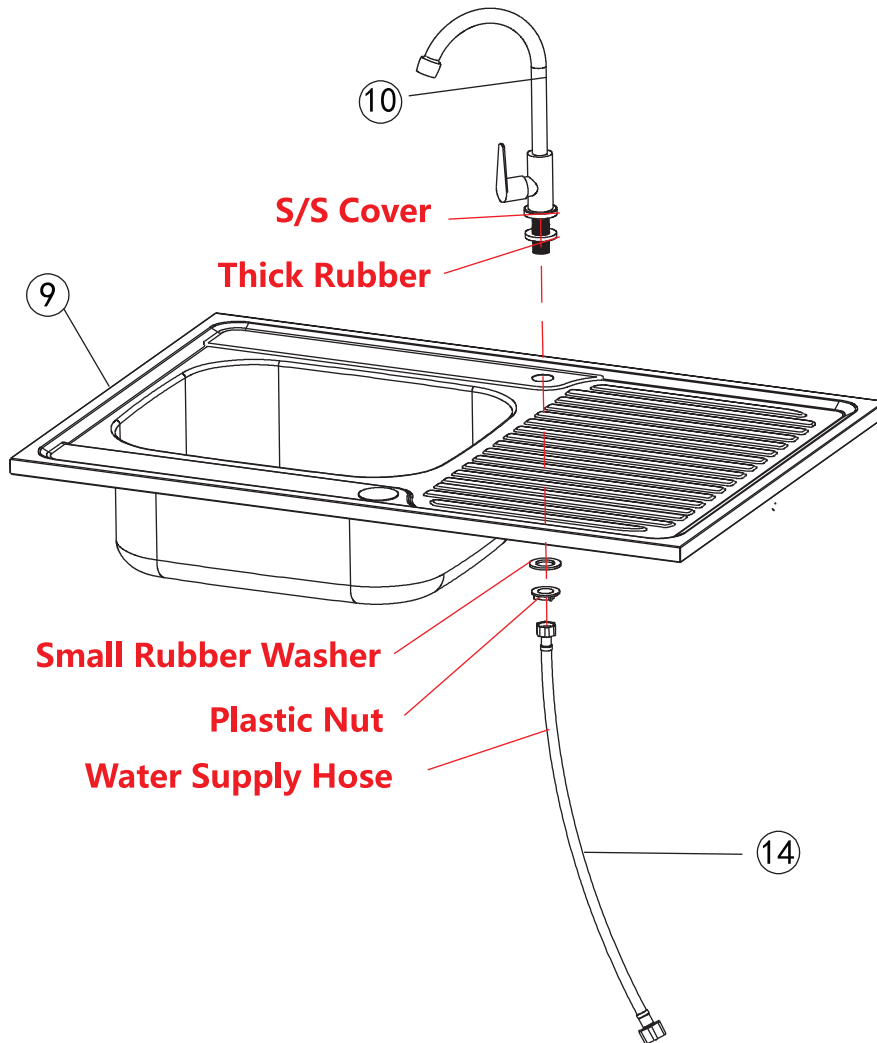
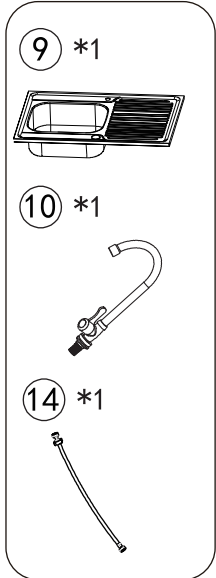

9

Install the drain assembly (11) into the sink portion of the counter top assembly by inserting the drain and large foam washer from the top. Next, from the bottom, install the large rubber washer and screw the large plastic nut onto the drain. Insert the strainer to the drain.

Insert the small rubber washer to the drain hose. Install the expanding drain hose to the drain by screwing the small plastic nut to the bottom of it.

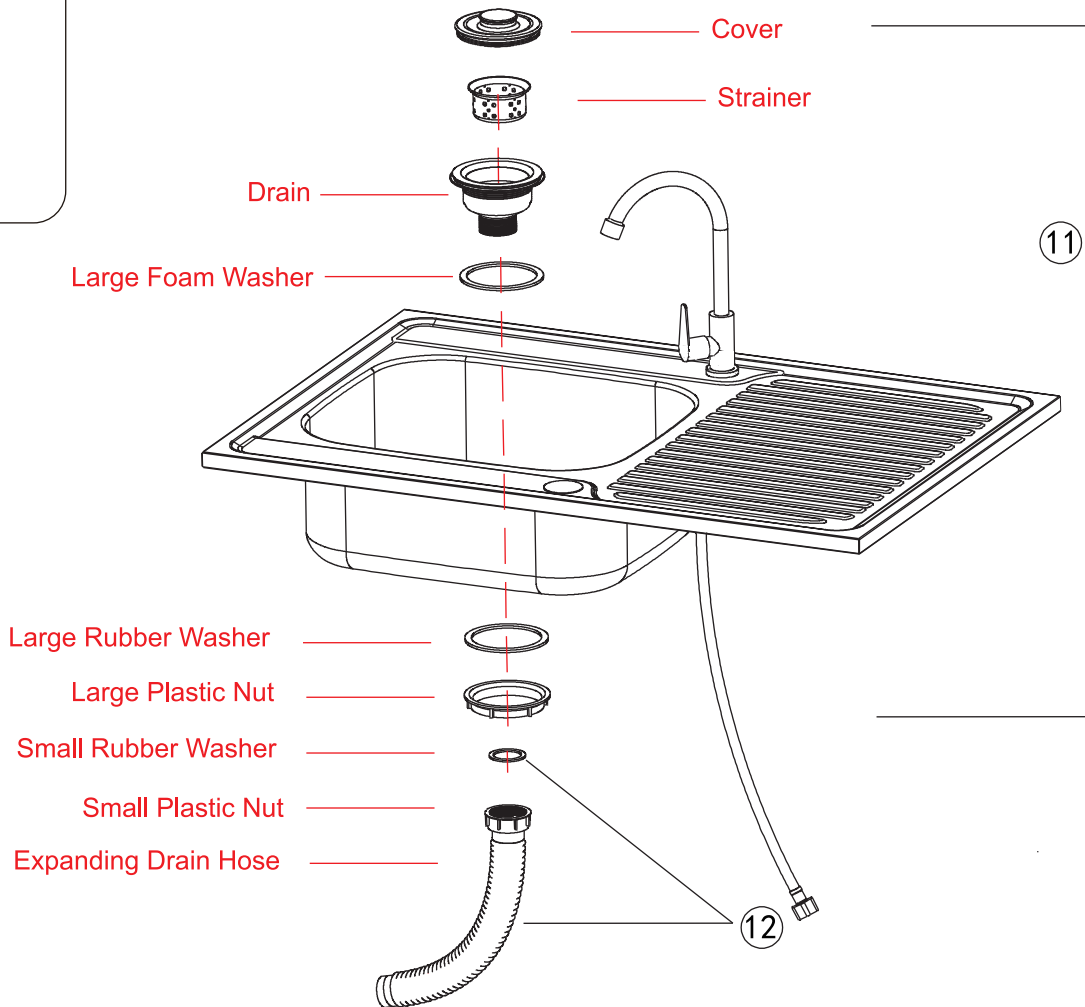
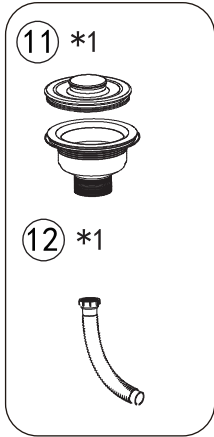

10

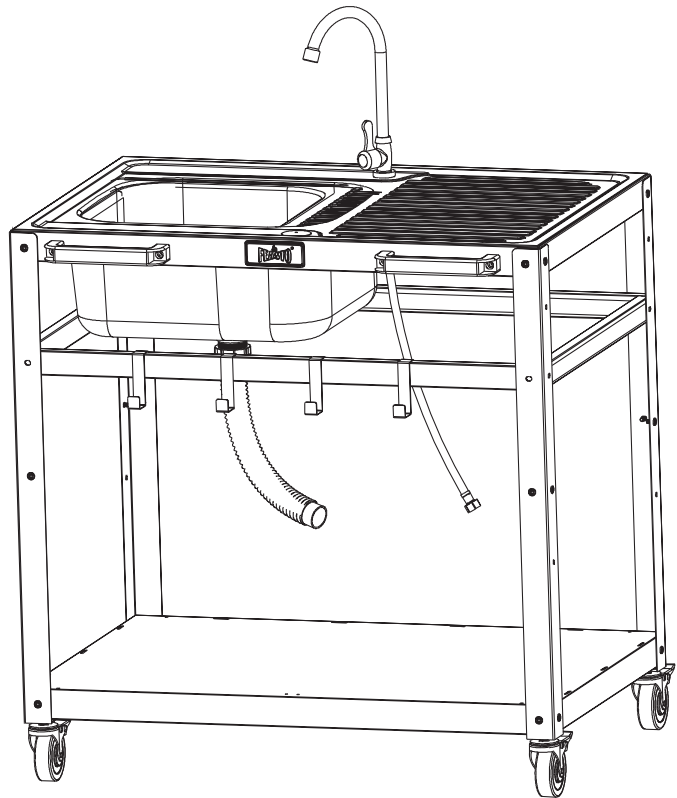
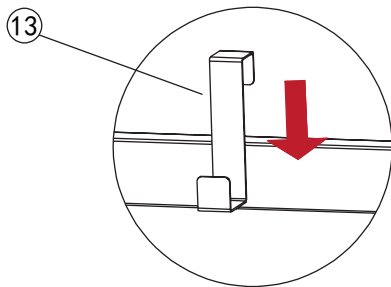
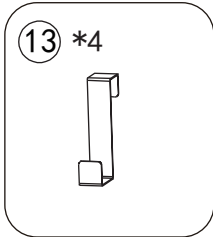

11

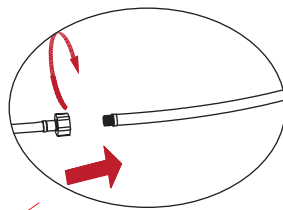
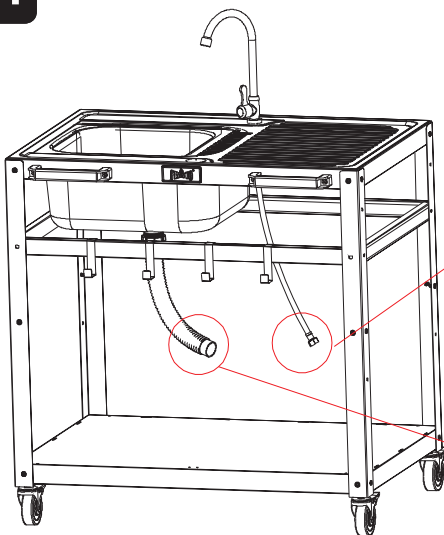

Screw the end of the water supply hose onto a garden hose that is attached to a water supply source. Make sure the faucet is off and turn on the garden hose and check for leaks. If there are leaks, turn off the garden hose, tighten the leaking fittings and repeat this step until the fitting is sealed and not leaking.

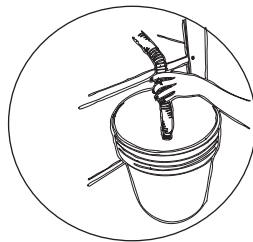

Position a bucket (not included) close by and place the end of the hose into the bucket. This bucket will serve to catch the waste water.

12

This outdoor sink unit can be used to add extra function and storage to FEASTO kitchen island unit KT2435A (not included).

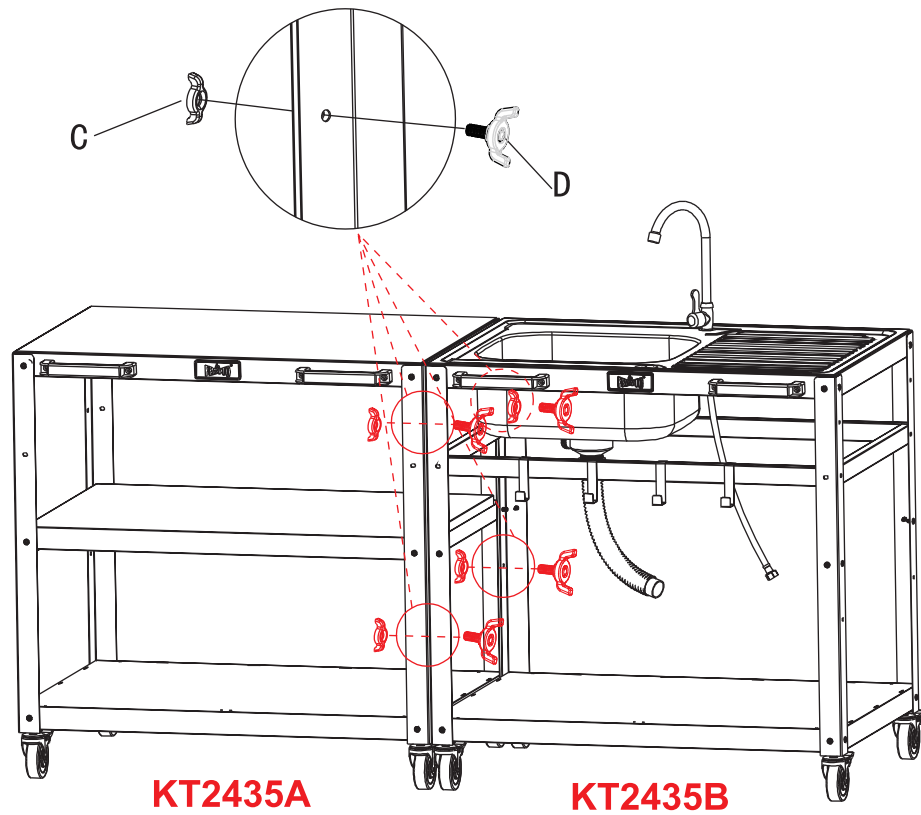
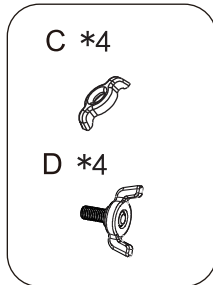

FEASTO warrants to the original consumer-purchaser only that this product shall be free from defects in workmanship and materials after correct assembly and under normal and reasonable home use for the periods, normal residential use and recommended care for 1-Year Limited Warranty from the date of original retail purchase. A replacement for any defective part will be supplied free of charge for installation by the consumer. Requests for expedited shipments of warranted parts will be at the consumer's/purchaser's expense. Defects or damage caused by the use of other than genuine parts are not covered by this warranty. This warranty shall be effective from the date of purchase as shown on the purchaser's receipt.

This warranty is valid for the original consumer/purchaser only and excludes industrial, commercial or business use of the product, product damage due to shipment or failure which results from alteration, product abuse or product misuse whether performed by a contractor, service company or consumer. We will not be responsible for labor charges and/or damage incurred in installation, repair or replacement, nor for incidental or consequential damage.

FEASTO garantiza al comprador-consumidor original únicamente que este producto estará libre de defectos en la mano de obra y los materiales después del montaje correcto y bajo uso doméstico normal y razonable durante los períodos, uso residencial normal y cuidado recomendado para la garantía limitada de 1 año a partir de la fecha de la compra minorista original. Se proporcionará un reemplazo de cualquier pieza defectuosa sin cargo para que el consumidor la instale. Las solicitudes de envíos acelerados de piezas garantizadas correrán a cargo del consumidor/comprador. Los defectos o daños causados por el uso de piezas que no sean originales no están cubiertos por esta garantía. Esta garantía entrará en vigencia a partir de la fecha de compra que se muestra en el recibo del comprador.

Esta garantía es válida únicamente para el consumidor/comprador original y excluye el uso industrial, comercial o empresarial del producto, el daño del producto debido al envío o la falla que resulte de la alteración, abuso del producto o uso indebido del producto, ya sea que lo realice un contratista, una empresa de servicios o un consumidor. No seremos responsables de los cargos por mano de obra y/o daños incurridos en la instalación, reparación o reemplazo, ni por daños incidentales o consecuentes.

FEASTO garantit à l'acheteur-consommateur d'origine uniquement que ce produit sera exempt de défauts de fabrication et de matériaux après un assemblage correct et dans des conditions d'utilisation domestique normales et raisonnables pendant les périodes, l'utilisation résidentielle normale et l'entretien recommandé pour la garantie limitée d'un an à compter de la date de l'achat initial au détail. Un remplacement pour toute pièce défectueuse sera fourni gratuitement pour l'installation par le consommateur. Les demandes d'expéditions accélérées de pièces sous garantie seront aux frais du consommateur/acheteur. Les défauts ou dommages causés par l'utilisation de pièces autres que des pièces d'origine ne sont pas couverts par cette garantie. Cette garantie entrera en vigueur à compter de la date d'achat indiquée sur le reçu de l'acheteur.

Cette garantie est valable pour le consommateur/acheteur d'origine uniquement et exclut l'utilisation industrielle, commerciale ou professionnelle du produit, les dommages au produit dus à l'expédition ou à une défaillance résultant d'une altération, d'un abus ou d'une mauvaise utilisation du produit, qu'ils soient effectués par un entrepreneur, une société de services ou un consommateur. . Nous ne serons pas responsables des frais de main-d'œuvre et/ou des dommages subis lors de l'installation, de la réparation ou du remplacement, ni des dommages accessoires ou consécutifs.



service@feastooutdoors.com



Mon-Fri, 8:30 AM-5:30 PM, EST

www.feastooutdoors.com