

# MALONE<sup>®</sup>

**MPG351-XL**

**CHANGING THE WAY YOU GET THERE**

## TELOS-XL

**KAYAK LIFT ASSIST**

*The TelosXL™ attaches to the MPG106 AutoLoader™, MPG114 DownLoader™, MPG118 J-Loader™ and the MPG107 SeaWing™ providing a safe and simple way to side load your kayak*



### ***Installation & Loading Instructions - Please Read Before Beginning***

*Veillez lire les instructions avant d'entreprendre l'installation et le chargement*

**IMPORTANT WARNING:** All vehicular transports are potentially hazardous. Any person(s) using Malone products are personally responsible for following the given directions for use and/or installation and accepts full responsibility for any and all damages or injury of any kind including death, which may result from their use and/or installation.

It is critical that all Malone racks and accessories be properly and securely attached to your vehicle. Improper attachment could result in a serious accident, and could cause serious bodily injury or death to you or to others. You are responsible for securing the racks and accessories to your car, checking the attachment's prior to use, and periodically inspecting the products for adjustment, wear, and damage.

You must read and understand all of the instructions and cautions supplied with your Malone products(s) prior to installation or use. If you do not understand all of the instructions and cautions, or, if you have no mechanical experience and are not thoroughly familiar with the installation procedures, you should have the product installed by a professional installer.

**MISE EN GARDE IMPORTANTE:** Tout transport d'un chargement sur le toit d'un véhicule est potentiellement dangereux. Une personne qui utilise les produits Malone doit suivre sans faute les instructions d'installation et d'utilisation fournies et assume l'entière responsabilité pour tout dommage ou toute blessure, y compris un décès, pouvant résulter d'une telle installation ou utilisation.

Il est essentiel de fixer correctement et solidement les supports et les accessoires à votre véhicule. Une mauvaise installation ou attache pourrait provoquer un accident, entraîner des blessures corporelles graves à vous et aux autres et même causer la mort. Vous avez la responsabilité de fixer solidement les supports et les accessoires à votre véhicule, de vérifier l'installation avant l'utilisation et d'inspecter périodiquement le produit pour déceler tout signe d'usure ou de dommage ou tout problème d'ajustement.

Vous devez lire et comprendre les instructions et les mises en garde fournies avec les produits Malone avant l'installation et l'utilisation. Si vous ne comprenez pas les instructions et les mises en garde ou si vous ne possédez pas d'expérience en mécanique et ne connaissez pas à fond les procédures à suivre d'installation, vous devriez faire monter et poser le produit par un installateur professionnel.

# MALONE<sup>®</sup>

CHANGING THE WAY YOU GET THERE

## IMPORTANT NOTE

### Product Warranty & Registration Form

All information is confidential and used exclusively by MALONE only.

Dear Customer,

Thank you for your purchase of a Malone Product.

In order to be eligible for the Malone Warranty program, we ask that you contact us online at the link provided below: With-in 30 days of purchase. You can also mail this letter back to the address at the bottom.

- Online: <https://maloneautoracks.com/product-registration.php>

We will require the information below.

Here is the information collected:

First Name: \_\_\_\_\_

Last Name: \_\_\_\_\_

Address: \_\_\_\_\_

Address2: \_\_\_\_\_

City: \_\_\_\_\_

State: \_\_\_\_\_

Zip: \_\_\_\_\_

Country: \_\_\_\_\_

Email: \_\_\_\_\_

Phone: \_\_\_\_\_

Product Description/Name: \_\_\_\_\_

Product MPG# \_\_\_\_\_

Date Purchased: \_\_\_\_\_

Store Where Purchased: \_\_\_\_\_

Purchase Price: \_\_\_\_\_

Thank you for choosing Malone!

MALONE AUTO RACKS 81 County Rd. Ste 1, Westbrook, ME 04092  
P: 207.774.9100 F: 207.615.0551  
E: [support@maloneautoracks.com](mailto:support@maloneautoracks.com) W: [www.maloneautoracks.com](http://www.maloneautoracks.com)

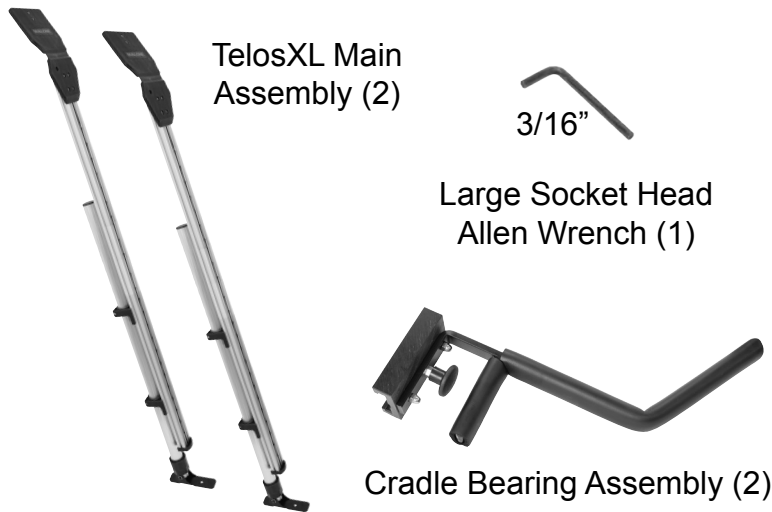

### SeaWing™ Fit Kit (1)

Small Socket Head Allen Wrench (1)

SeaWing™ Pin Template (1)

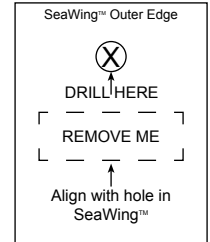

Small Socket Head Screw (2)

Visit [www.maloneautoracks.com/Replacement-Parts](http://www.maloneautoracks.com/Replacement-Parts) for all of your spare part needs

## ASSEMBLY (Installing the cradle bearing to the TelosXL™ main assembly)

- 1). Using the large 3/16" allen wrench, begin by removing the end-cap at the bottom of the main assembly. See figure 1.
- 2). Align the cradle bearing to the front side of the main assembly and slide it on until it stops by the lower lockout. Pull up on the locking pull pin and slide the bearing past the lower lock-out. See figure 2.

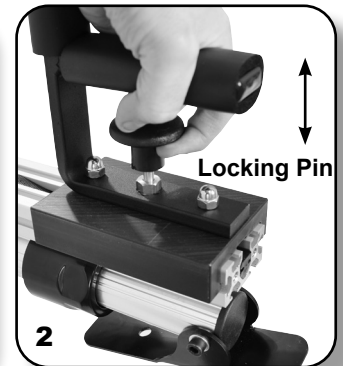

- 3). Reattach the end cap. Note the rounded edge faces upwards. See figure 3.
- 4). Test and confirm smooth travel of the bearing by sliding it back and forth. Push to raise, pull the locking pin to lower. Repeat for second bearing and main assembly. See figure 4.

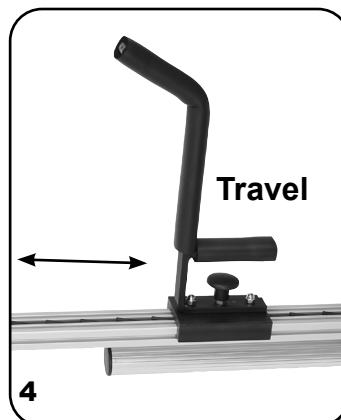

This concludes the assembly.

## INSTALLATION & USE *(Installing the TelosXL™ to the Loading Ramp of the MPG106, MPG114, MPG118)*

First, confirm that the kayak carriers are secure and located directly inside the cross rail towers. You'll dress the straps as described in your kayak carriers instructions.

**NOTE: NEVER MOUNT THE CARRIERS OUTSIDE OF THE CROSS RAIL TOWERS. THIS APPLIES TO BOTH FACTORY AND AFTER-MARKET CROSS RAILS.**

1). Position the TelosXL™ so the attachment clip is located on the rear of the top mounting plate and aligns with the slot in the carriers loading ramp. See figure 1.

Insert and pull-down to engage the attachment clip.

2). With the top plate secured, loosen the knobs on the assembly connector on the backside and slide the extender downwards until the black locking collar is clear of the bottom. Fully tighten the knobs. See figure 2

3). Loosen the black locking collar and slide the extension out to the desired length to reach the ground. Twist to secure the collar in place and flip the foot pedal out to complete installation. See figures below.

**NOTE: When extending the TelosXL™ to the ground we want to keep the unit as close to the vehicle as possible, or as vertical as possible without making contact. This will insure easier function and use.**

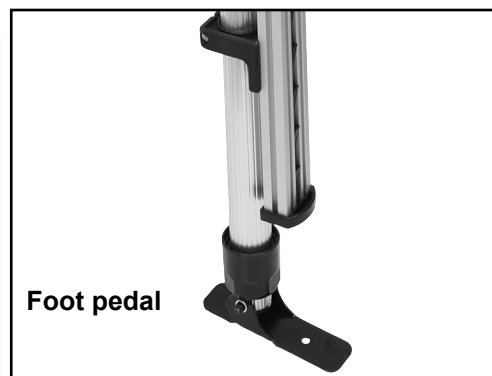
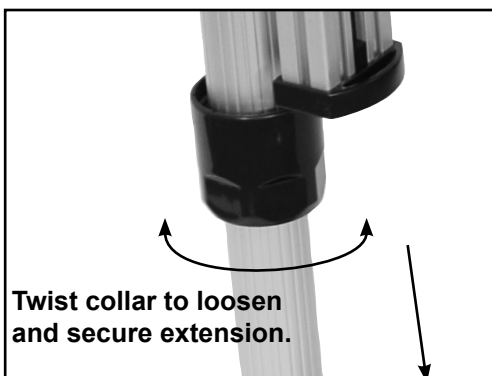

This concludes the J-Style installation.

## INSTALLATION & USE (Installing the TelosXL™ to the MPG107 SeaWing™)

**NOTE:** Using the TelosXL™ with older SeaWing™ carriers requires the user to drill a small hole and replace a bolt in the top mounting plate. Use the provided template below to insure proper placement of the required hole if your carriers do not have one already.

**IF** your carriers contain this hole already, just install the longer bolt as pictured below and skip to the next steps.

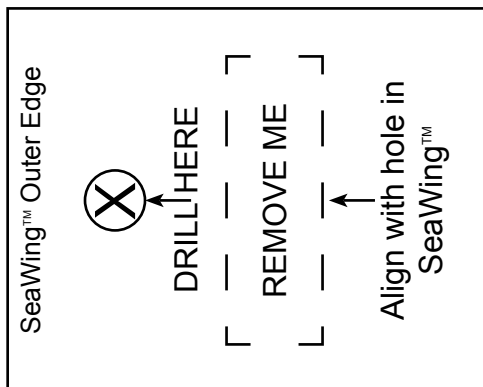

1). First, remove the template above and carefully cut out the center hole marked 'remove'.

2). Place the template over the SeaWing™ outer hole as pictured below and mark the location of the required hole.

3). Using a 3/8" bit, carefully drill the hole into the SeaWing™. Repeat these steps for the 3 remaining holes.

4). Remove the top bolt securing the attachment clip and replace it with the longer one provided.

This new bolt will act as a pin, preventing the Telos from moving during the loading procedure.

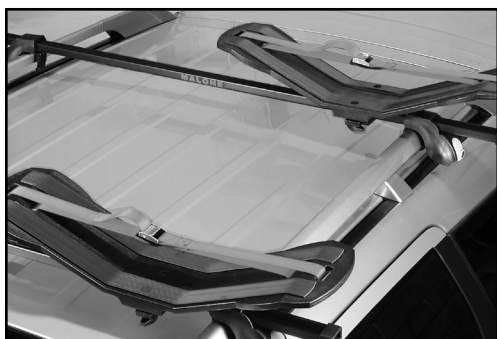
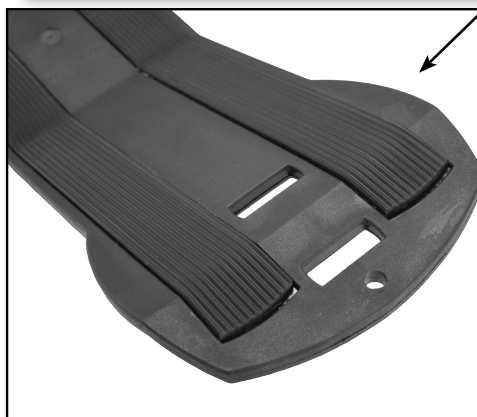
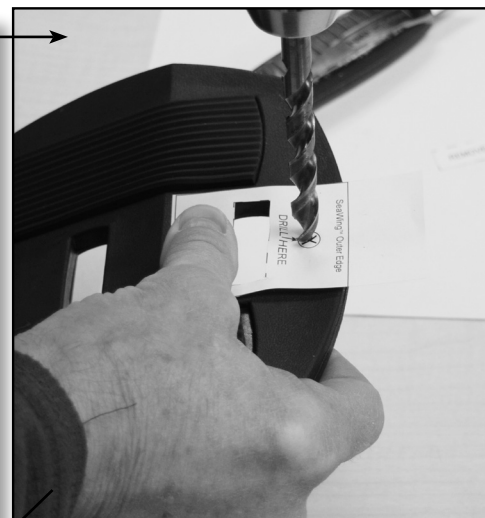

First, confirm that the kayak carriers are secure and located directly inside the cross rail towers. You'll dress the straps as described in your kayak carriers instructions.

**NOTE: NEVER MOUNT THE CARRIERS OUTSIDE OF THE CROSS RAIL TOWERS. THIS APPLIES TO BOTH FACTORY AND AFTER-MARKET CROSS RAILS.**

## INSTALLATION & USE (Installing the TelosXL™ to the MPG107 SeaWing™)

**NOTE:** Using the TelosXL™ with older SeaWing™ carriers requires the user to drill a small hole and replace a bolt in the top mounting plate. Use the provided template below to insure proper placement of the required hole if your carriers do not have one already.

**IF** your carriers contain this hole already, just install the longer bolt as pictured below and skip to the next steps.

**CUT ME OUT**

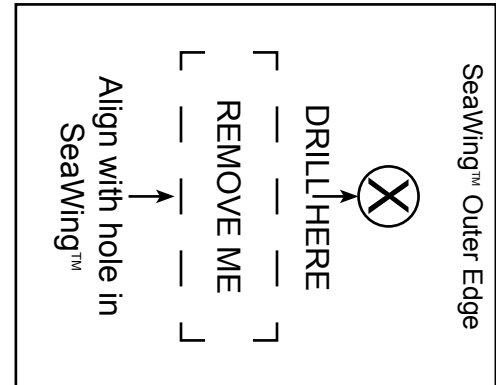

1). Position the TelosXL™ so the attachment clip is located on the rear of the top mounting plate and aligns with the slot in the SeaWing™. See figure 1.



Insert and pull-down to engage the attachment clip and seat the bolt into the hole. The bolt prevents the Telos™ from rotating during the loading procedures.

2). With the top plate secured, loosen the knobs on the assembly connector on the backside and slide the extender downwards until the black locking collar is clear of the bottom. Fully tighten the knobs. See figure 2



3). Loosen the black locking collar and slide the extension out to the desired length to reach the ground. Twist to secure the collar in place and flip the foot pedal out to complete installation.

See figures below.

**NOTE:** When extending the TelosXL™ to the ground we want to keep the unit as close to the vehicle as possible, or as vertical as possible without making contact. This will insure easier function and use.

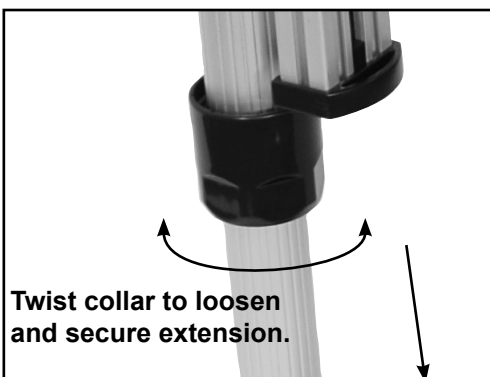

This concludes the Saddle Style installation.

## LOADING & UNLOADING YOUR KAYAK

1). Begin with pulling up on locking pin and lower the cradle bearings to their lowest point.

Fold the side mirror in to avoid contact and damage.

Lift and gently place kayak into the cradles with the cockpit facing out. Position the kayak so it is vertical.

**NOTE: If the kayak does not fit into the cradles - STOP.  
Call Malone (207).887.1070 for details.**

2). Grip the lower section of one cradle while stepping on the foot pedal. Gently apply upward pressure and raise the kayak 6"- 8". The mechanism will automatically lock in place when pressure is released.

3). Grip the lower section of the other cradle (while stepping on the foot pedal). Gently apply upward pressure and raise the kayak 12"-16".

**NOTE: This is only a approximate distance. You will find your own 'comfort zone' of distance to lift based upon individual size and kayak weight.**

4). Continue to raise the kayak in this fashion (front then rear) until the top locking position is reached for both cradles.

**NOTE: This process should be done in a slow controlled manner. Avoid getting either the front or rear of the kayak at too great of an angle.**

5). Standing directly between the cradles, grip the bottom of the kayak and gently push up and in, allowing the kayak to rotate and drop down into the carriers.

**Note: Sometimes it is easier and requires less effort to maneuver the kayak into the carriers one side at a time.**

**Note: If the vehicle is too high, we recommend a small foot stool be used during this process. The unit should be portable so that it can be taken to the put-in site.**



## LOADING & UNLOADING YOUR KAYAK CONT.

6). With the kayak now loaded into the carriers, remove the TelosXL™ assembly from the vehicle and dress the straps as defined in your carriers instructions.

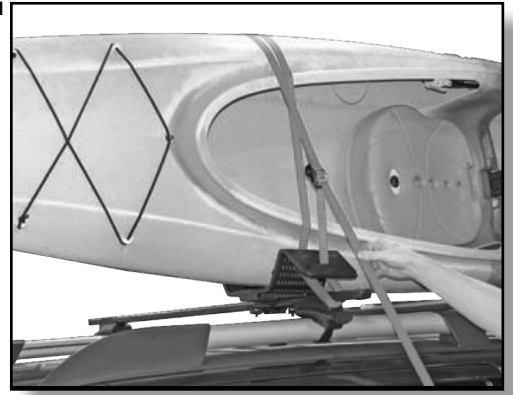

1). To lower the kayak, unbuckle the straps and install both TelosXL™ assemblies as described in the beginning steps.

Raise both cradles to the top position and carefully push up and pull out the kayak so it slides down the loading ramp of the carrier and into the TelosXL™ cradles.



2). Grip the lower section of one cradle and gently apply upward pressure. With the other hand, pull the locking pin out and slowly lower the kayak 6" to 8".

Release the locking pin to stop downward travel.

Repeat process for other cradle. Continue to lower the kayak in this manner until the cradles reach the bottom.



3). Remove the kayak from the Telso™ cradles  
Remove the TelosXL™ assemblies and store away.  
Remove all load straps.



*Compress size & Store in the vehicle when not in use.*

# **MALONE**

**CHANGING THE WAY YOU GET THERE**

## **Limited Lifetime Warranty**

The Malone Auto Racks (Malone) Limited Lifetime Warranty covers certain Malone-brand products that have been specifically identified for inclusion in the program and is effective for as long as the original retail purchaser owns the product. This warranty is terminated when the original retail purchaser sells or otherwise transfers the product to any other person or entity.

Subject to the limitations and exclusions described in this warranty, Malone will remedy defects in materials and/or workmanship by repairing or replacing, at its option, a defective product without charge for parts or labor. Malone may elect, at its option, not to repair or replace a defective product but rather issue to the original retail purchaser a refund equal to the purchase price paid for the product, or credit to be used toward the purchase of a replacement Malone product.

This warranty does not cover, and no warranty is given for defects or problems caused by normal wear and tear, which includes, but is not limited to, surface (aesthetic) metal corrosion, scratches, dents, deformities, accidents, unlawful vehicle operation, or any modification of a product not performed or authorized in writing by Malone.

In addition, this warranty does not cover problems resulting from conditions beyond Malone's control including, but not limited to, theft, misuse, overloading, or failure to assemble, mount or use the product in accordance with Malone's written instructions or guidelines included with the product provided to the original retail purchaser.

No warranty is given for Malone products purchased outside of the continental United States, Canada and Mexico.

If the product is believed to be defective, the original retail purchaser should contact the Malone dealer from whom it was purchased, who will give the original retail purchaser instructions on how to proceed. If the original retail purchaser is unable to contact the Malone dealer, or the dealer is not able to remedy the defect, the original retail purchaser should contact Malone by email at [support@maloneautoracks.com](mailto:support@maloneautoracks.com).

In the event that the product must be returned to Malone, a technician at the email address above will provide the original purchaser with return shipping instructions. The original purchaser will be responsible for the cost of mailing the product to Malone. In order to be eligible to receive any remedy under this warranty, a copy of the original purchase receipt, a description of the defect and a return address must be provided.

## **Disclaimer of Liability**

Repair or replacement of a defective product, or the issue of a refund or credit (as determined by Malone) is the original retail purchaser's sole and exclusive remedy under this warranty. Damage to original purchaser's vehicle, cargo, or property, and/ or to any other person or property is not covered by this warranty.

This warranty is expressly made in lieu of any and all other warranties, express or implied, including the warranties of merchantability and fitness of a particular purpose

Malone's sole liability to any purchaser is limited to the remedy set forth above. In no event will Malone be liable for any direct, indirect, consequential, incidental, special, exemplary, or punitive damages , or, for any other damages of any kind or nature (including but not limited to, lost profits, lost income or lost sales).

Some states do not allow the exclusion or limitation of incidental or consequential damages, so the above limitations may not be applicable.

In addition, all vehicular transports are potentially hazardous. Any person(s) using Malone products are personally responsible for following the given directions for use and/or installation and accepts full responsibility for any and all damages or injury of any kind including death, which may result from their use and/or installation.

**MALONE AUTO RACKS 81 County Rd. Ste 1, Westbrook, ME 04092**  
**P: 207.774.9100 F: 207.615.0551**  
**E: [support@maloneautoracks.com](mailto:support@maloneautoracks.com) W: [www.maloneautoracks.com](http://www.maloneautoracks.com)**

# **MALONE**

## **CHANGING THE WAY YOU GET THERE**

### **Garantie à vie limitée**

La garantie à vie limitée de Malone Auto Racks (Malone) couvre certains produits de marque Malone expressément désignés pour être inclus dans ce programme et est valide tant que l'acheteur original est propriétaire du produit. Cette garantie prend fin lorsque l'acheteur original vend ou cède le produit à une autre personne ou entité.

Sous réserve des restrictions et exclusions prévues dans la garantie, Malone corrigera toute défectuosité matérielle et/ou tout défaut de fabrication en réparant ou en remplaçant, à sa discrétion, un produit défectueux sans frais pour ce qui est des pièces et de la main-d'oeuvre. Malone peut décider, à son choix, de ne pas réparer ou remplacer un produit défectueux, mais plutôt d'accorder à l'acheteur original un remboursement d'un montant égal au prix d'achat pour le produit ou encore un crédit pour l'achat d'un produit de remplacement de marque Malone.

La présente garantie ne couvre pas les défauts et les problèmes résultant d'une usure normale et aucune garantie n'est offerte à cet égard, notamment en cas de corrosion du métal en surface (esthétique), d'égratignures, de bosses, de déformations, d'accident, d'une utilisation illégale du véhicule ou de toute modification du produit qui n'est pas effectuée ou autorisée par écrit par Malone.

En outre, la garantie ne couvre pas les problèmes résultant de circonstances échappant au contrôle de Malone, y compris, notamment, résultant d'un vol, d'un usage abusif ou d'une surcharge ou encore d'un assemblage, d'une installation ou d'une utilisation du produit ne respectant pas les instructions écrites de Malone fournies à l'achat à l'acheteur original.

Aucune garantie n'est offerte pour des produits Malone achetés à l'extérieur du territoire continental des États-Unis, du Canada ou du Mexique.

Si le produit semble défectueux, l'acheteur original doit contacter le détaillant Malone où il a fait son achat et celui-ci lui fournira des renseignements sur la démarche à suivre. Si l'acheteur original ne réussit pas à contacter le détaillant Malone ou encore si le détaillant est incapable de remédier à la défectuosité, l'acheteur original doit communiquer directement avec Malone par courriel à l'adresse suivante : [support@maloneautoracks.com](mailto:support@maloneautoracks.com).

Dans le cas où le produit doit être retourné à Malone, un technicien contacté à l'adresse courriel ci-dessus fournira à l'acheteur original les instructions à suivre pour l'expédition du produit. L'acheteur original devra assumer les frais d'expédition à Malone. Pour qu'une demande soit admissible aux termes de la présente garantie, il faut envoyer à Malone une copie du reçu de l'acheteur original, une description de la défectuosité et une adresse de retour.

### **Exonération de responsabilité**

La réparation ou le remplacement du produit défectueux ou encore la remise d'un remboursement ou d'un crédit (tel que déterminé par Malone) constitue le seul et exclusif dédommagement offert à l'acheteur original aux termes de la présente garantie. Les dommages causés au véhicule de l'acheteur original, à un chargement, à ses biens et/ou à toute autre personne ou tout autre bien ne sont pas couverts par cette garantie.

Cette garantie est octroyée expressément afin de remplacer toute autre garantie expresse ou implicite, y compris toute garantie de qualité marchande ou de conformité pour un usage particulier.

L'unique responsabilité de Malone envers l'acheteur se limite aux dédommagements indiqués ci-dessus. Malone ne pourra en aucun cas être tenu responsable des dommages directs, indirects, consécutifs, spéciaux, exemplaires ou punitifs ou de tout autre dommage de quelque nature que ce soit (y compris notamment une perte de profits, de revenus ou de ventes).

L'exclusion ou la limitation des dommages indirects ou consécutifs n'étant pas permise à certains endroits, les limitations indiquées ci-dessus peuvent ne pas s'appliquer.

En outre, tous les transports par véhicule comportent des risques potentiels. Toute personne utilisant un produit Malone est donc personnellement responsable de suivre les instructions fournies pour son utilisation et/ou son installation et accepte l'entière responsabilité pour tout dommage ou toute blessure de quelque nature que ce soit, y compris un décès, pouvant résulter de son utilisation et/ou son installation.

**MALONE AUTO RACKS 81 County Rd. Ste 1, Westbrook, ME 04092**

**P: 207.774.9100 F: 207.615.0551**

**E: [support@maloneautoracks.com](mailto:support@maloneautoracks.com) W: [www.maloneautoracks.com](http://www.maloneautoracks.com)**