



**BLACK HORSE
OFF ROAD®**

TEL: 1-866-XANATOS

INSTALLATION INSTRUCTIONS

ARMOUR III LD FRONT BUMPER

19-23 DODGE RAM 1500

(Excl. 19-23 Classic, 19-22 Diesel, 19-23 Rebel and 21-23 TRX)

PART# AR3LD30NL

(EXCLUDES 19-23 "CLASSIC," 19-22 DIESEL, 19-23 REBEL, 21-23 TRX)

PARTS LIST:

1	CS1 Front Bumper	8	10mm Hex Nuts
1	Upper Mesh Panel	2	8mm x 35mm Bolt Plates
1	Center Mesh Panel	2	8mm Plastic Retainers
1	Driver/Left Frame Bracket	4	8-1.25mm x 25mm Hex Bolts (Stainless)
1	Passenger/Right Frame Bracket	2	8-1.25mm x 16mm Hex Bolts (Stainless)
1	Driver/Left Support Bracket	8	8mm x 24mm x 2mm Flat Washers (Stainless)
1	Passenger/Right Support Bracket	4	8mm Lock Washers (Stainless)
1	Driver/Left Bumper Bracket	4	8mm Hex Nuts (Stainless)
1	Passenger/Right Bumper Bracket	6	8-1.25mm x 30mm Hex Bolts
2	LED "L" Brackets	10	8mm x 24mm x 2mm Flat Washers
1	License Plate Bracket	8	8mm Lock Washers
2	License Plate Plugs	4	8mm Hex Nuts
2	20mm x 10mm Foam Spacer	6	6-1.0mm x 20mm Combo Bolts
2	15.5mm x 25mm x 2mm Foam Seals	2	6-1.0mm x 20mm Button Head Bolts
2	Retaining Caps	4	6mm x 18mm x 1.6mm Flat Washers
2	Sensor Plastic Plugs	2	6mm Nylon Lock Nuts
1	Sensor Cover Kit	4	4mm Self Tapping Screws
4	10mm x 40mm Double Bolt Plates	1	3000mm Edge Trim
8	10mm x 30mm x 2.5mm Flat Washers	10	Plastic Wire Ties
8	10mm Lock Washers	1	4mm Wrench

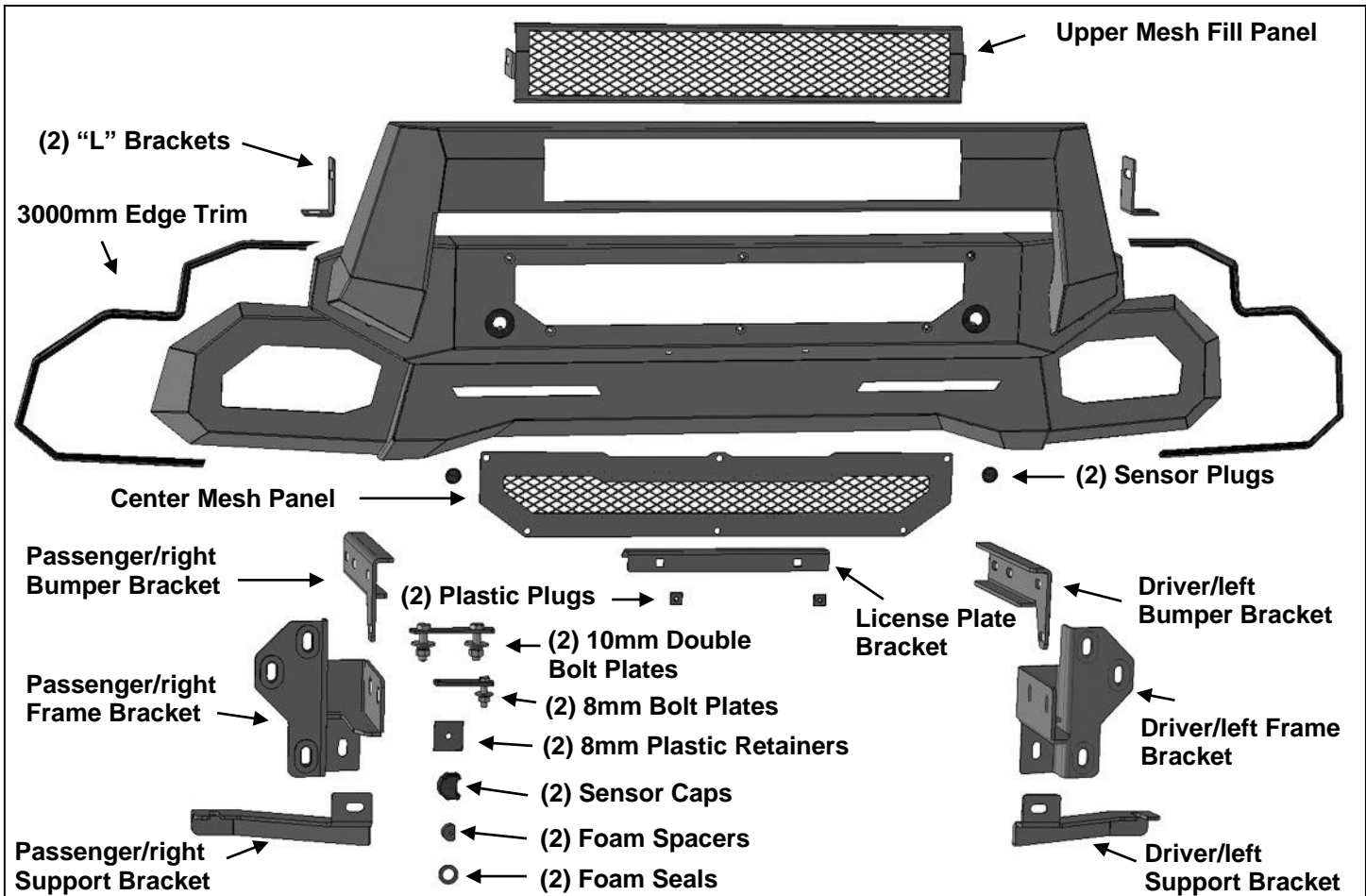

PROCEDURE:

REMOVE CONTENTS FROM BOX. VERIFY ALL PARTS ARE PRESENT. READ INSTRUCTIONS CAREFULLY BEFORE STARTING INSTALLATION. ASSISTANCE IS RECOMMENDED TO AVOID POSSIBLE INJURY OR DAMAGE TO THE VEHICLE.

1. Remove the license plate and bracket if equipped.
2. From below/behind the bumper, release the clips attaching the center plastic panel to the opening in the bumper, **(Figures 1 & 2)**. Unplug wiring harness to sensors in panel if equipped. **NOTE:** Models with automatic air dam, it may be easier to temporarily remove the air dam assembly for CS1 bumper bracket installation.
3. On the driver/left side of the bumper, remove the inner (2) factory bolts attaching the bumper to the frame, **(Figure 3)**.
4. Select the Single Bolt Plate and Plastic Retainer, **(Figure 4)**. Insert the Bolt Plate through the hole in the bumper bracket, **(Figure 5)**. Thread the Plastic Retainer onto the Bolt Plate to help hold the Bolt Plate in place. **NOTE:** Plastic Retainer use is optional.
5. Select the driver/left Frame Bracket, **(Figure 6)**. Attach the Bracket to the Bolt Plate with (1) 8mm Flat Washer, (1) 8mm Lock Washer and (1) 8mm Hex Nut. Next, attach the Frame Bracket to the (2) threaded holes in the bumper bracket with the included (2) 8mm x 30mm Hex Bolts, (2) 8mm Lock Washers and (2) 8mm Flat Washers, **(Figures 7 & 8)**. Do not fully tighten hardware at this time.
6. Next, **loosen but do not remove** the body bolt from the bottom of the frame, **(Figure 9)**. On models with tow hooks, this is the rear mounting bolt. Select the driver/left Support Bracket, **(Figure 10)**. Slide the slotted end of the Support Bracket under the head of the body bolt, **(Figure 11)**. Attach the bent end of the Support Bracket to the back of the Frame Bracket with (1) 8mm x 30mm Hex Bolt, (2) 8mm Flat Washers, (1) 8mm Lock Washer and (1) 8mm Hex Nut, **(Figures 10 & 12)**. Do not fully tighten hardware at this time.

(EXCLUDES 19-23 "CLASSIC," 19-22 DIESEL, 19-23 REBEL, 21-23 TRX)

7. Select the driver/left Bumper Bracket, **(Figure 13)**. Attach the Bumper Bracket to the inner facing side of the Frame Bracket with (1) 10mm Double Bolt Plate, (2) 10mm Flat Washers, (2) 10mm Lock Washers and (2) 10mm Hex Nuts, **(Figure 14)**. Do not fully tighten hardware at this time.
8. Repeat **Steps 3—7** to install the passenger/right side Brackets.
9. Carefully unwrap the CS1 Bumper. Attach the included Edge Trim to the edge of the CS1 Bumper, **(Figure 15)**. Cut Edge Trim as necessary.
10. Determine if vehicle is equipped with parking sensors.

Models without sensors:

- a. Push the included (2) Plastic Plugs into the sensor mounting holes in the CS1 Bumper, **(Figure 16)**. Skip to **Step 11**.

Models with parking sensors.

- a. Remove the (2) sensors from the plastic center panel removed in **Step 2**.
 - b. Select (1) sensor. Remove the silicone seal from the end of the sensor. Slide the included larger Foam Sensor Seal over front of sensor, **(Figure 17)**.
 - c. Insert sensor with Seal into sensor mount on the CS1 Bumper, **(Figure 18)**.
 - d. Place Foam Spacer onto the end of sensor. Push on the Sensor Retaining Cap and snap onto the sensor mount, **(Figure 18)**.
 - e. Repeat Steps to install the remaining sensor.
11. Determine if accessory light, (not included), or Upper Mesh Fill Panel will be installed at this time.

Bar style LED light (not included).

- a. Select (1) "L" Light Bracket. Attach the Bracket to the slot in the back of the Bumper with (1) 8mm x 25mm Hex Bolt, (2) 8mm Flat Washers, (1) 8mm Lock Washer and (1) 8mm Hex Nut, **(Figure 19)**. Do not tighten hardware at this time.
- b. Repeat previous Step to attach the passenger/right Bracket.
- c. Select the light, (not included). Attach light to "L" Brackets with the hardware included with the light or (2) 8mm x 16mm Hex Bolts, (2) 8mm Lock Washers and (2) 8mm Flat Washers, **(Figure 19)**. Adjust the width of the Brackets to the light and fully tighten bracket hardware.

Screen Fill Panel Installation (do not install fill panel if installing lights).

- a. Select (1) "L" Light Bracket. Attach the Bracket to the slot in the back of the Bumper with (1) 8mm x 25mm Hex Bolt, (2) 8mm Flat Washers, (1) 8mm Lock Washer and (1) 8mm Hex Nut, **(Figure 19)**. Do not tighten hardware at this time.
 - b. Repeat previous Step to attach the passenger/right Bracket.
 - c. Select the long Upper Fill Panel. Attach the tabs on the Panel to the "L" Brackets with the included (2) 8mm x 25mm Hex Bolts, (4) 8mm Flat Washers, (2) 8mm Lock Washers and (2) 8mm Hex Nuts, **(Figure 20)**. Push the Fill Panel up against the back of the opening, align, adjust and fully tighten hardware.
12. With assistance, position the CS1 Bumper Assembly up to the inside of the Frame Brackets. Temporarily support the weight of the Bumper. **WARNING:** To avoid possible injury or damage to the vehicle, do not proceed until the Bumper is fully and safely supported.
 13. Insert (1) 10mm Double Bolt Plate into the center opening in the CS1 Bumper, under the Bumper Bracket and through the Bumper and Bracket, **(Figure 21)**. Attach the Bumper to the Bracket and Double Bolt Plate with (2) 10mm Flat Washers, (2) 10mm Lock Washers and (2) 10mm Hex Nuts, **(Figures 22 & 23)**. Do not fully tighten at this time. Repeat this **Step** to attach the passenger/right side of the CS1 Bumper to the Brackets.
 14. Level and adjust the CS1 Bumper and fully tighten all hardware.
 15. Models with front license plate, attach the License Plate Bracket to the front of the Bumper with the included (2) 6mm x 20mm Button Head Bolts, (4) 6mm Flat Washers and (2) 6mm Nylon Lock Nuts, **(Figure 24)**. Push the included (2) Plastic Plugs into the square holes in the Bracket. Reuse the factory hardware to attach the license plate to the Plastic Plugs.
 16. Plug the bumper wire harness into the sensors if equipped.
 17. Attach the Center Mesh Fill Panel to the front of the Bumper with the included (6) 6mm Button Head Combo Bolts, **(Figure 25)**.
 18. Do periodic inspections to the installation to make sure that all hardware is secure and tight.

(EXCLUDES 19-23 "CLASSIC," 19-22 DIESEL, 19-23 REBEL, 21-23 TRX)

To protect your investment, Do not use any type of polish or wax that may contain abrasives that could damage the finish. Mild soap may be used to clean the Bumper assembly.

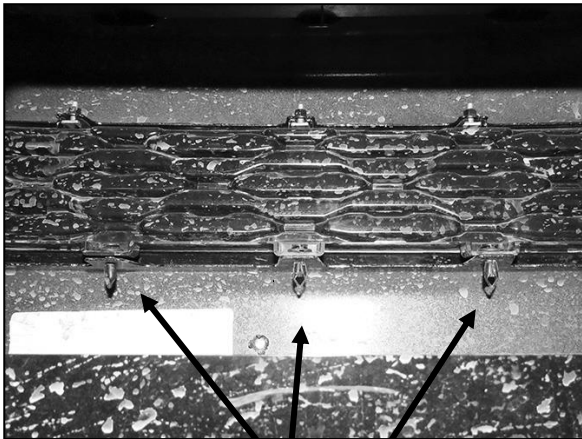

(Fig 1) Release the clips attaching the center plastic panel to the back of the outer bumper cover. **NOTE:** Panel pictured from behind bumper



(Fig 2) Center panel removed. Models with sensors, unplug sensors to remove panel



(Fig 3) Remove the (2) inner bumper bracket bolts (arrows). Driver/left side pictured from behind bumper

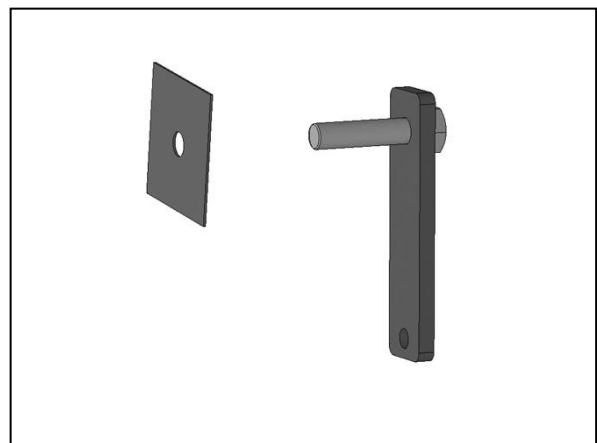

(Fig 4) From the front, insert Bolt Plate through hole in factory bumper bracket. Thread Plastic Retainer onto Bolt Plate

Driver/left Side Installation Pictured

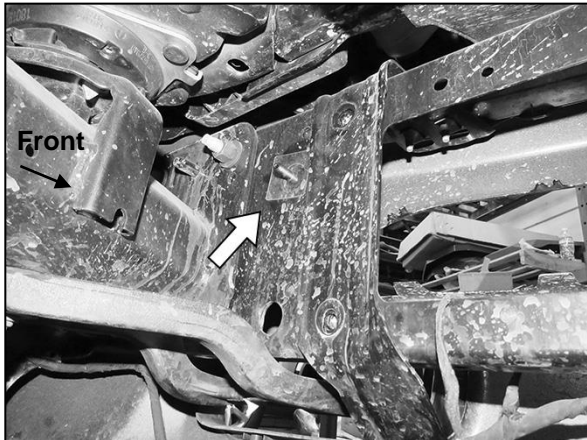

(Fig 5) Insert Bolt Plate through driver/left side bumper bracket (arrow)

8mm Flat Washer
8mm Lock Washer
8mm Hex Nut

8mm Bolt Plate

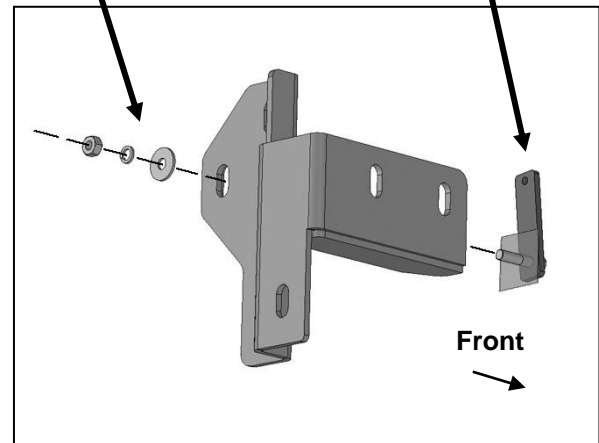

(Fig 6) Attach the driver/left Frame Bracket to the Bolt Plate

(2) 8mm x 30mm Hex Bolts
(2) 8mm Lock Washers
(2) 8mm Flat Washers

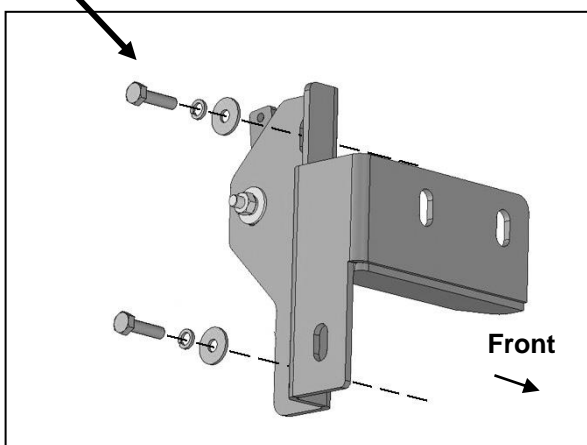

(Fig 7) Attach the driver/left Frame Bracket to the (2) threaded holes



(Fig 8) Driver/left Frame Bracket attached to threaded holes in back of factory bumper bracket (arrows)

Driver/left Side Installation Pictured



(Fig 9) Loosen but do not remove body mount bolt (arrow). Model with tow hook pictured

8mm x 30mm Hex Bolt
(2) 8mm Flat Washers
8mm Lock Washer
8mm Hex Nut

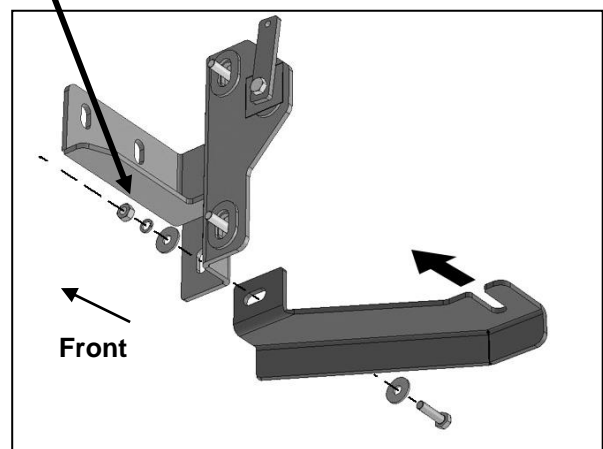

(Fig 10) Slide slotted end of Support Bracket under head of body bolt (fig 12)



(Fig 11) Slide driver/left Support Bracket between tow hook (or spacer on bottom of frame) and body bolt



(Fig 12) Attach bent end of Support Bracket to back of Frame Bracket (arrow)

(EXCLUDES 19-23 "CLASSIC," 19-22 DIESEL, 19-23 REBEL, 21-23 TRX)

Driver/left Side Installation Pictured

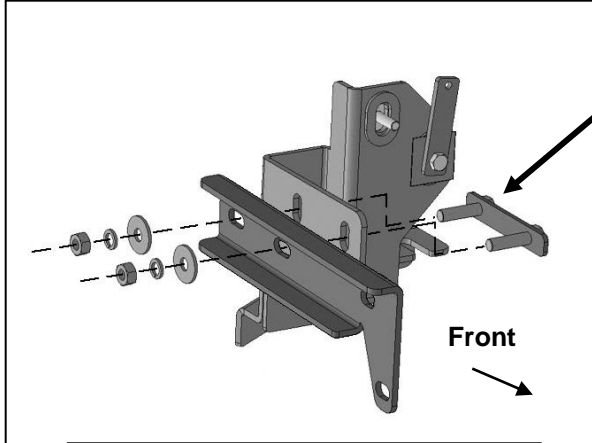

- 10mm Double Bolt Plate
- (2) 10mm Flat Washers
- (2) 10mm Lock Washers
- (2) 10mm Hex Nuts

(Fig 13) Attach driver/left Bumper Bracket to inside of Frame Bracket

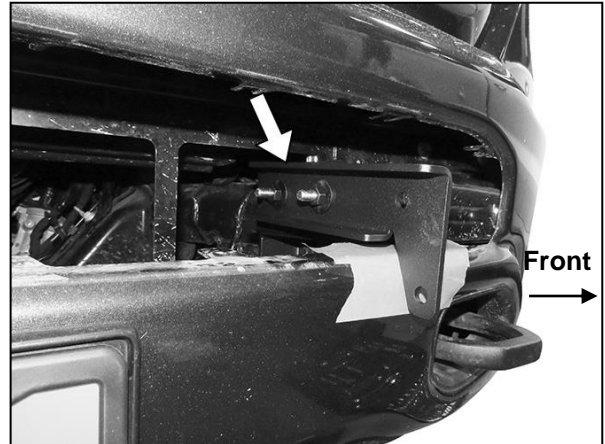

(Fig 14) Driver/left Bumper Bracket installed

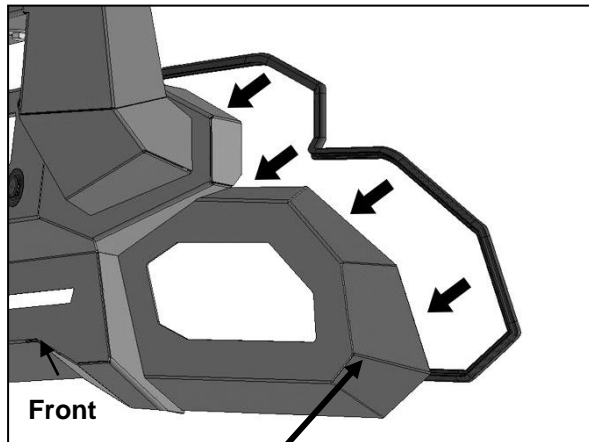

(Fig 15) Push Edge Trim onto edge of CS1 Bumper (arrows). Cut Edge Trim to fit

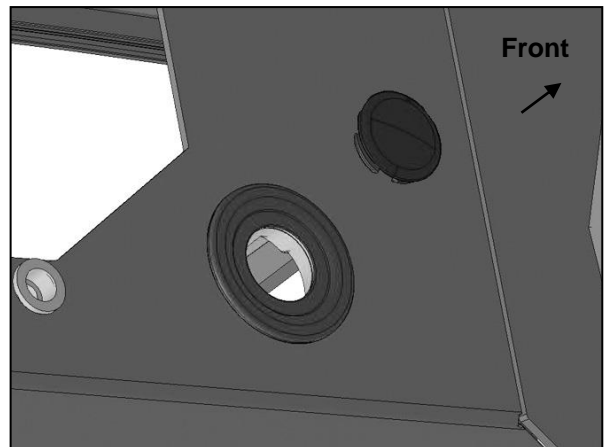

(Fig 16) Models without sensors, push Plastic Plugs into sensor mounts



(Fig 17) Remove silicone seal from sensor. Slide large Seal over end of sensor (arrow)

Driver/left Side Installation Pictured

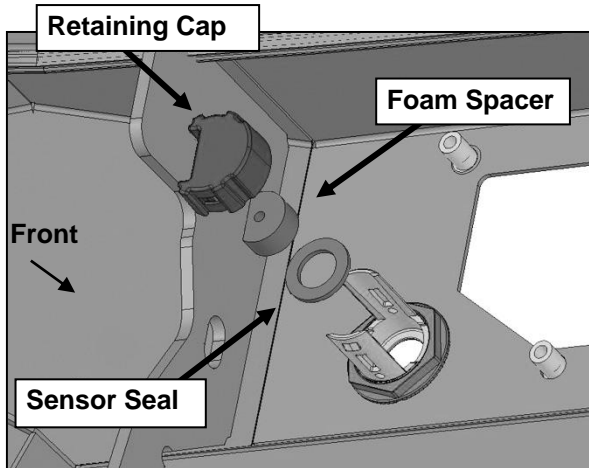

(Fig 18) Push sensor into back of Sensor Mount

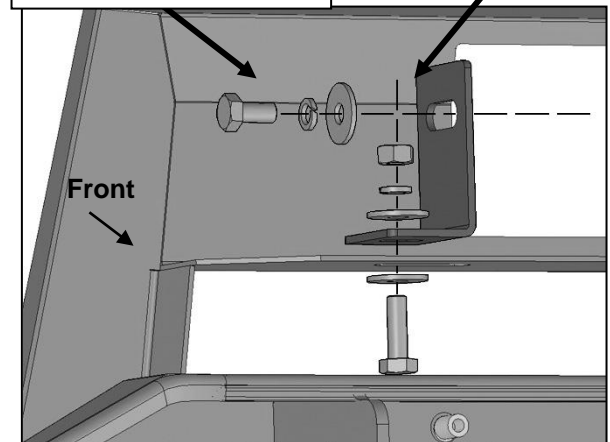
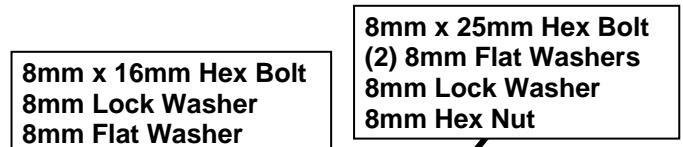

(Fig 19) Attach "L" Brackets if installing LED center light (not included) or Center Fill Panel

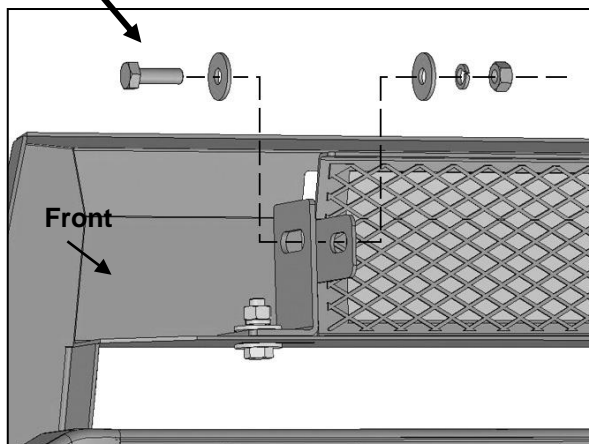

(Fig 20) Attach Center Fill Panel to "L" Brackets
(Do not install Fill Panel with LED light)

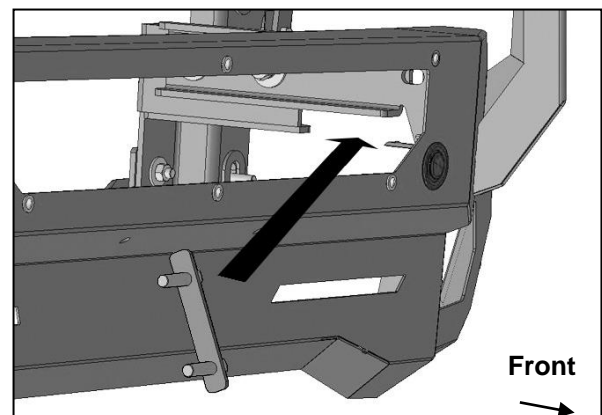

(Fig 21) Insert Double Bolt Plate under and back through Bumper Bracker and Bumper

Driver/left Side Installation Pictured

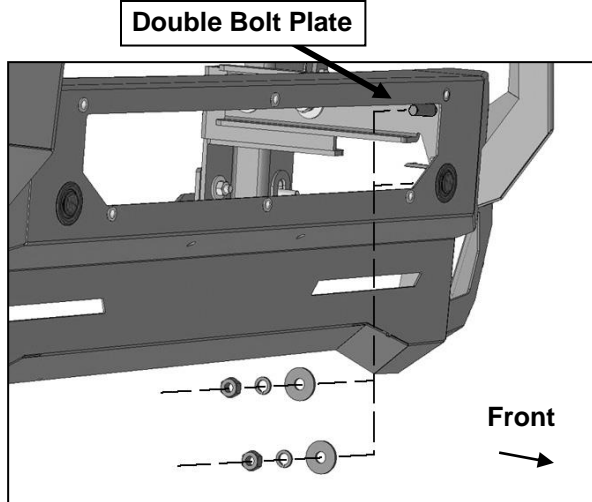

(Fig 22) Attach Bumper to Bracket and Double Bolt Plate

WARNING! Do not crawl under bumper unless it is properly supported on blocks or stands or the bumper may fall.

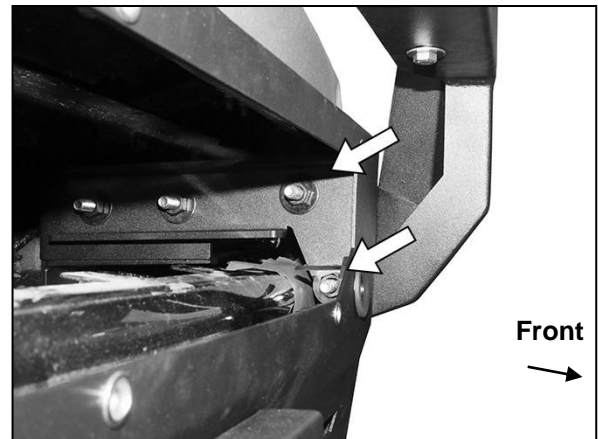

(Fig 23) Driver/left side of Bumper attached to Bracket and Double Bolt Plate (arrows)

- (2) 6mm x 20mm Button Head Bolts
- (4) 6mm Flat Washers
- (2) 6mm Nylon Lock Nuts

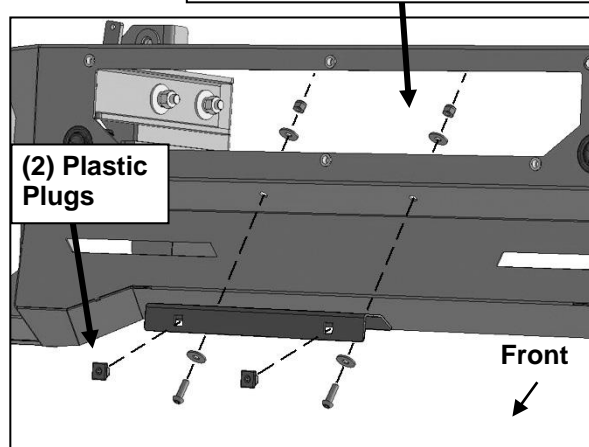

(Fig 24) Attach License Plate Bracket to Bumper

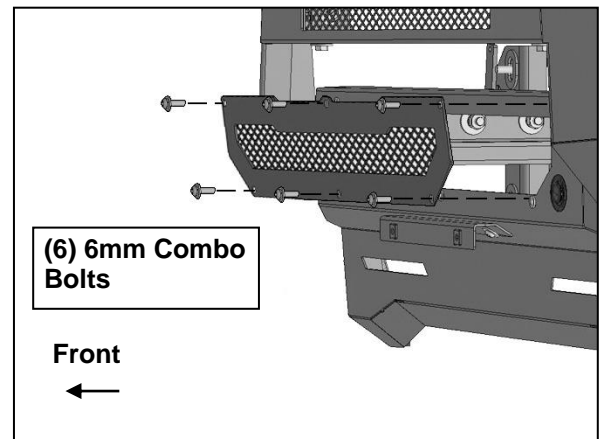

(Fig 25) Attach center Fill Panel (optional)