

OPERATOR'S MANUAL

Utility Vehicle

MX 550/750

Record Product Information

Before setting up and operating your new utility vehicle please locate the model plate and record the information in the provided area to the right. You can locate the model plate by looking on the frame above the left rear tire.

See the image below. This information will be necessary, should you seek technical support via our web site, Customer Support Department, or with a local authorized service dealer.

Model Number

Serial Number

WARNING

Read and follow all safety rules and instructions in this manual before attempting to operate this vehicle.

Failure to comply with these instructions may result in personal injury - SAVE THESE INSTRUCTIONS.

WARNING

CALIFORNIA PROPOSITION 65

Engine Exhaust, some of its constituents, and certain vehicle components contain or emit chemicals known to the State of California to cause cancer and birth defects or other reproductive harm. www.p65warnings.ca.gov

Battery posts, terminals, and related accessories contain lead and lead compounds, chemicals known to the State of California to cause cancer and reproductive harm. Wash hands after handling.

NOTE: This Operator's Manual covers several models. Features may vary by model. Not all features in this manual are applicable to all models and the model depicted may differ from yours.

SAFE OPERATION PRACTICES

WARNING



This symbol points out important safety instructions which, if not followed, could endanger the personal safety and/or property of yourself and others. Read and follow all instructions in this manual before attempting to operate this vehicle. Failure to comply with these instructions may result in personal injury. When you see this symbol. HEED ITS WARNING!

DANGER

This vehicle was built to be operated according to the safe operation practices in this manual. As with any type of off-highway utility vehicle, carelessness or error on the part of the operator can result in serious injury. Failure to observe the following safety instructions could result in serious injury or death.

FAILURE TO FOLLOW THE WARNINGS CONTAINED IN THIS MANUAL CAN RESULT IN SERIOUS INJURY OR DEATH.

GENERAL OPERATION

1. Read, understand, and follow all instructions on the vehicle and in the manual before attempting to operate or service vehicle. Keep this manual in a safe place for future and regular reference and for ordering replacement parts.
2. This is an off-highway utility vehicle and it should not be operated on public highways. Know and comply with all laws and regulations governing the use of off-highway vehicles in your area.
3. This vehicle handles and maneuvers differently than a normal passenger car. Sharp high speed turns and abrupt maneuvers can cause vehicle to roll over or go out of control. Slow down when turning and avoid abrupt maneuvers.
4. Handling and maneuvering characteristics of vehicle change depending upon cargo load. Heavy loads affect steering, braking, stability, and overall handling of vehicle.
5. Be familiar with all instructions and controls and their proper operation before starting vehicle.
6. Never allow adults to operate this vehicle without proper instruction.
7. Never allow children under 16 years old to operate this vehicle. Children 16 years old and over should read and understand the operation instructions and safety rules in this manual and should be trained and supervised by a parent unless driver has obtained a state-issued motor vehicle driver's licence.
8. Watch for traffic when operating near or crossing roadways. This vehicle is not intended for use on any public roadway.
9. Do not operate this vehicle while under the influence of alcohol or drugs.
10. Never carry more than one passenger. This vehicle is designed to carry the driver and one passenger only. No riders are allowed in cargo box or anywhere else on vehicle, except in the driver and passenger seats.
11. Keep all body parts (i.e. head, arms, hands, legs, feet) inside vehicle when vehicle is in motion.
12. Always remain seated and keep both hands on the steering wheel when driving the vehicle.
13. Sit on the center of the seat and keep both feet within the foot platform perimeter. Clean foot platform if dirty and remove any debris from around foot controls, e.g. brake pedal.
14. Do not misuse the vehicle. Reckless operation can lead to accidents, severe bodily injury or death.
15. Inspect area around vehicle before moving, especially in reverse. Back up slowly. Always look down and behind before and while backing to avoid a back-over accident. Keep bystanders out of area.
16. Avoid driving through water, since loss of control may occur. Drive belt may slip if exposed to water thus reducing vehicle pulling power and stopping vehicle entirely. Water depth should not exceed 15" (38 cm).
17. Always use vehicle lights while operating in low light situations.
18. Do not mount or leave vehicle while it is in motion or in actual operation.
19. Avoid sudden starts, stops, or turns and always use a level turn-around area.
20. Never leave vehicle unattended with the engine running. Move the shift lever to "PARK" position, turn ignition key to the "OFF" position and remove the key.
21. Check overhead clearances carefully before driving under low hanging tree branches, wires, power lines, bridges, before entering or leaving buildings, or in any other situation where the operator and/or occupant protection structure (OPS) may be struck, which could result in serious injury.
22. Always use the occupant protection structure (OPS) and seat belt for safe operation. Overturning the utility vehicle without an OPS, or with an OPS and the seat belt unfastened, can result in death or injury.
23. Always use the seat belt and never remove the occupant protection structure (OPS) or operate the vehicle without the OPS.

SAFE OPERATION PRACTICES

24. The doors are designed to assist in keeping the operator and passenger inside the vehicle during operation. Do NOT operate vehicle without doors in place.
25. Improper use of the vehicle or failure to properly maintain it could result in decreased vehicle performance or personal injury.
26. Engine must be stopped when cleaning, servicing, adjusting, repairing, or installing attachments on utility vehicle.
27. After striking foreign objects, stop the vehicle, and shut off the engine. Inspect for damage and repair the damage before restarting and operating.
28. Do not start or operate vehicle in an inside area, unless it is adequately ventilated. Engine exhaust contains carbon monoxide fumes, which are very poisonous and can be deadly.
29. Assure safety interlock switch is adjusted correctly so engine cannot be started unless gearshift is in the "PARK" position with the brake pedal depressed.
30. Do not touch engine or exhaust components while engine is running or soon after it is stopped. They will be hot and can cause a burn.
31. Always inspect your vehicle each time you use it to make sure it is in safe operating condition. Always follow the inspection and maintenance procedures and schedules described in this manual.
32. Do not use the differential lock when driving down hill. Do not use the differential lock at speeds over 25 mph. Allow for greater turning radius and more difficult steering when the differential lock is engaged.
33. If situations occur which are not covered in this manual, use care and good judgement. Contact your local service center or call toll free 1-877-282-8684 for the name of your nearest service center.

Occupant size and capacity

1. Make sure operators are at least 16 years old and have a valid driver's license.
2. Each occupant should be able to sit with their back against the seat, feet flat on the floor, and hands on the steering wheel or handholds.
3. The operator should be tall enough to wear the seat belt properly and reach all controls.
4. Passengers should also be tall enough for the seat belt to fit properly and be able to brace themselves, as necessary, by placing both feet firmly on the floor while gripping the handholds. Keep all body parts completely inside the vehicle.

Dress Properly

1. Proper clothing can reduce the severity of injury in the event of an accident.
2. Always wear appropriate eye protection and protective clothing. It is also recommended that you wear a properly fitting D.O.T. approved helmet.

Slope Operation

Slopes are a major factor related to loss of control and rollover accidents, which can result in severe injury or death. If a slope is steeper than a 15° incline, do not operate this vehicle on that area. Exercise extreme caution while operating on slopes.

DO:

1. Travel straight up and down slopes, not across. Exercise extreme caution when changing direction on slopes.
2. Travel slowly while on a slope. Always keep the forward speed limited when going down slopes to take advantage of the engine braking action.
3. Keep all movement on the slopes slow and gradual. Avoid starting or stopping on a slope.
4. Avoid slopes with slippery, loose, or bumpy surfaces as they are especially hazardous.
5. Use extra care while carrying cargo. It may affect the stability of the vehicle. Spread the load evenly and tie down.

DO NOT:

1. Do not travel near drop-offs, ditches, or embankments. The vehicle could suddenly turn over if a wheel is over the edge of a cliff, ditch, or if an edge caves in.
2. Do not stop or start suddenly when going uphill or downhill. Be especially cautious when changing direction on slopes.
3. Do not turn sideways to the hill. The vehicle may roll over. If you must turn, go slow and do so carefully and gradually.
4. Do not carry cargo or tow loads on steep slopes.

Towing

1. Always use an approved hitch and hitch point provided on the utility vehicle.
2. Do not tow more than 1200 lbs (544 kg) rolling weight (i.e. trailer plus cargo).
3. Never load more than 110 lbs (50 kg) tongue weight on tow bracket provided.
4. Go slow and use extra care when towing a trailer. Allow for increased braking distance. Load trailer properly.
5. Do not tow heavy loads on slopes greater than 5° incline. When going downhill or turning, the extra weight tends to push the tow vehicle and may cause you to lose control (i.e. braking and steering ability are reduced, towed equipment may jack-knife and cause utility vehicle to overturn).

SAFE OPERATION PRACTICES

Cargo Box Loading/Operation

1. Do not exceed vehicle's Total Load Capacity rating of 1000 lbs (453.5 kg). This includes operator, passenger, accessories, and cargo.
2. Do not exceed 500 lbs (226.7 kg) load in cargo box.
3. Spread load evenly and secure to prevent movement.
4. Do not load above height of cargo box front panel. Load could shift forward and injure driver or passenger.
5. Avoid loads which exceed the physical dimensions of cargo box.
6. Go slow. Heavy loads will affect steering, braking, stability, and overall handling of the vehicle. Limit loads to those that can be safely controlled.
7. Avoid sudden starts, stops, and turns which could cause load to shift.

Cargo Box Lift

1. Stop vehicle on level ground, move the shift lever into the "PARK" position before raising cargo box.
2. On manual lift units, unload cargo box before raising cargo box.
3. Do not operate vehicle with cargo box in raised position.
4. Do not operate vehicle with cargo box latch unlatched. Always re-latch upon manually lowering cargo box.

WHEN USING OPTIONAL ELECTRIC LIFT:

- a. Stay in driver's seat.
- b. Keep body parts away from cargo box and keep all bystanders away.
- c. Do not allow rear wheels to hang over the edge of a drop-off when raising cargo box. The load in the cargo box may shift causing the vehicle to tip over backwards.

SAFETY FRAME (OPS)

1. Your vehicle is equipped with an occupant protection structure (OPS) which must be maintained in a fully functional condition. Use care when driving through doorways or spaces with a low overhead.
 - a. Never modify the OPS in any way.
 - b. Never attempt to straighten or reweld any part of the main frame or retaining brackets that have been damaged. Doing so may weaken the structure and endanger your safety.
 - c. Never secure any parts other than manufacturer approved accessories on the main frame or attach the safety frame with anything other than the special fasteners specified.
 - d. Never attach ropes, chains, or cables to the OPS for pulling purposes.

- e. Although the OPS, when used with a properly secured seat belt, provides a crush-protective environment in the event of a tip-over or rollover, never take unnecessary risks.

CHILDREN

1. Tragic accidents can occur if the operator is not alert to the presence of children. Children are often attracted to the vehicle. They do not understand the dangers. Never assume that children will remain where you last saw them. Avoid run over accidents.
 - a. Keep children out of the immediate area of the vehicle and in watchful care of a responsible adult other than the operator.
 - b. Be alert and turn the vehicle off if a child enters the area.
 - c. Before and while backing, look behind and down for small children.
 - d. Never carry small children, they may fall off and be seriously injured or interfere with safe vehicle operation.
 - e. Use extreme care while approaching blind corners, doorways, shrubs, trees, or other objects that may block your vision of a child who may run into the path of the vehicle.
 - f. Remove key when vehicle is unattended to prevent unauthorized operation.
2. Never allow children under 16 years old to operate this vehicle. Children 16 years old and over should read and understand the operation instructions and safety rules in this manual, should be trained and supervised by a parent and have obtained a state-issued motor vehicle driver's license.
3. Do not let children ride in the cargo box, in the driver's or passenger's lap or anywhere other than the passenger seat. Never give small children a ride; not even in the passenger seat. They may fall off.

SERVICE

Safe Handling of Fuel:

1. To avoid personal injury or property damage use extreme care in handling fuel. Fuel is extremely flammable and the vapors are explosive. Serious personal injury can occur when fuel is spilled on yourself or your clothes which can ignite. Wash your skin and change clothes immediately.
 - a. Use only an approved fuel container.
 - b. Never carry or fill containers inside the vehicle's bed or on a truck or trailer. Always place containers on the ground away from your vehicle before filling.
 - c. When practical, remove gas-powered vehicle from the truck or trailer and refuel it on the ground. If this is not possible, then refuel on a trailer with a portable container, rather than from a fuel dispenser nozzle.

SAFE OPERATION PRACTICES

- d. Keep the nozzle in contact with the rim of the fuel tank or container opening at all times until fueling is complete. Do not use a nozzle lock-open device.
 - e. Extinguish all cigarettes, cigars, pipes, and other sources of ignition.
 - f. Never fuel indoors.
 - g. Never remove gas cap or add fuel while the engine is hot or running. Allow engine to cool at least five minutes before refueling.
 - h. Never over fill fuel tank. Fill tank to no more than one inch below bottom of filler neck to allow space for fuel expansion. Leave additional room for fuel expansion if the utility vehicle will be in a high-altitude situation.
 - i. Replace fuel cap and tighten securely.
 - j. If fuel is spilled, wipe it off immediately. Move vehicle to another area. Wait five minutes before starting the engine.
 - k. To reduce fire hazards, keep engine compartment and exhaust system free of grass, leaves, or other debris build-up. Clean up oil or fuel spillage and remove any fuel soaked debris.
 - l. Never store the vehicle or fuel container inside where there is an open flame, spark or pilot light as on a water heater, space heater, furnace, clothes dryer, or other gas appliances.
11. Follow the vehicle maintenance and service schedules to ensure that all mechanical and safety systems are working properly and not worn excessively. Failure to do so can result in accidents, injuries, or death.
 12. Observe proper disposal laws and regulations for gas, oil, etc. to protect the environment.
 13. Prior to disposal, determine the proper method to dispose of waste from your local Environmental Protection Agency. Recycling centers are established to properly dispose of materials in an environmentally safe fashion.
 14. Use proper containers when draining fluids. Do not use food or beverage containers that may mislead someone into drinking from them. Properly dispose of the containers immediately following the draining of fluids.
 15. Do NOT pour oil or other fluids into the ground, down a drain or into a stream, pond, lake, or other body of water. Observe Environmental Protection Agency regulations when disposing of oil, fuel, coolant, brake fluid, filters, batteries, tires, and other harmful waste.
 16. We do not recommend the use of a pressure washer to clean your vehicle. They may cause damage to electrical components; wheel spindles; pulleys; bearings; or the engine. The use of high-pressure water will result in shortened life and reduce serviceability.

General Service

1. Never run an engine indoors or in a poorly ventilated area. Engine exhaust contains carbon monoxide, an odorless, and deadly gas.
2. Before cleaning, repairing, or inspecting, make certain all moving parts have stopped. Remove the key to prevent unintended starting.
3. Check brake operation frequently as it is subjected to wear during normal operation. Adjust and service as required.
4. The cooling system is under pressure, never remove the radiator cap when the system is hot. Slowly turn the cap to the first stop to release pressure before removing the cap.
5. Keep all nuts, bolts, and screws tight to be sure the vehicle is in safe working condition.
6. Never tamper with the safety interlock system or other safety devices. Check their proper operation regularly.
7. Never attempt to make adjustments or repairs to the vehicle while the engine is running.
8. Wait for vehicle to cool before servicing exhaust or coolant system.
9. Stop vehicle on level ground. Place shift lever in park before servicing.
10. Maintain or replace safety and instruction labels, as necessary.

DO NOT MODIFY ENGINE

To avoid serious injury or death, do not modify engine in any way. Tampering with engine can lead it to operate at unsafe speeds. Never tamper with factory setting of the engine and its components.

NOTICE REGARDING EMISSIONS

Where applicable, this vehicle is certified to federal EPA and California Air Resources Board (CARB) emissions standards for Off-Highway Recreational Vehicles (OHRV). The Engine Owner's Manual is supplied by the engine manufacturer, and provides additional information relating to the emission system, warranty, and maintenance of the engine in accordance with EPA and/or CARB regulations. Consult your engine manual for the fuel requirements for your engine.

Gasoline powered products may be equipped with the following emission control systems: Engine Modification (EM), Oxidizing Catalyst (OC), Oxygen Sensor (O2S), Multi-port Fuel Injection (MFI), Electronic Control Module (ECM), Secondary Air Injection (SAI) and Three Way Catalyst (TWC). When required, models are equipped with low permeation fuel lines and fuel tanks for evaporative emission control. Please contact Customer Support for information regarding the evaporative emission control configuration for your model.

SAFE OPERATION PRACTICES

SPARK ARRESTOR

⚠️ WARNING

This vehicle is equipped with an internal combustion engine and should not be used on or near any unimproved forest-covered, brush-covered, or grass-covered land unless the engine's exhaust system is equipped with a spark arrestor meeting applicable local or state laws (if any).

SAFETY LABELS

Safety labels that may appear on the product are reproduced on this page. Read, understand, and follow all instructions on the machine before attempting to assemble and/or operate.

⚠️ WARNING

Severe **INJURY** or **DEATH** can result if you ignore the following guidelines:

- Maximum load in cargo bed is 500lb (227kg).
- Never carry passengers in cargo bed. Passengers can be thrown off causing serious injury or death.
- Cargo can affect handling and stability.
- Read Owner's Manual before loading or towing.
- When operating with cargo or towing a trailer always reduce speed, allow more room to stop and avoid hills and rough terrain.
- Be sure cargo is secured since a loose load can change vehicle handling.
- Keep weight in the cargo bed centered and as low and as far forward as possible.
- Top-heavy loads increase the risk of rollover.

⚠️ WARNING

NEVER CARRY PASSENGERS IN CARGO BED.



⚠️ WARNING

- Improperly loading a trailer and failure to use extra care when pulling trailer can cause an accident or injury.
- Never load more than 1100lbs (50kg) tongue weight on the towing bracket.
- Do not tow more than 1200lbs (544kg) rolling weight (trailer plus cargo).
- Operate in low-range gears only, allow for increased braking distance, and use extreme caution when operating on inclines.
- Read carefully the loading information and trailer hitch sections in the owners manual.

⚠️ WARNING

You could be severely injured if you try to stop a vehicle rollover using your arm or leg. If vehicle starts to rollover, keep arms and legs inside vehicle.

⚠️ WARNING

Improper Use of Off-Highway Vehicle Can Cause Severe Injury or Death

Do Not Operate This Vehicle on Public Roads

Do Not Operate This Vehicle on Public Roads

Do Not Operate This Vehicle on Public Roads



⚠️ WARNING

Operation takes more effort while the vehicle is in 4WD-LOCK. When in 4WD-LOCK operate at a slow speed and allow extra time and distance for turns to avoid loss of control.

⚠️ WARNING

Operation of this equipment may create sparks that can start fires around dry vegetation. A spark arrestor may be required. The operator should contact local fire agencies for laws or regulations relating to fire prevention requirements.

⚠️ WARNING

- Keep hands and body safely away when closing bed.
- NEVER operate the vehicle with the bed up.



⚠️ WARNING

Turn speed not to exceed **18 MPH (30 KPH)**

Do not drive in the water deeper than **15in (38cm)**.

⚠️ CAUTION

Use **LOW** when driving slow, hauling a load or driving uphill for longer clutch & belt life.

⚠️ WARNING

Improper tire pressure or overloading can cause loss of control. Loss of control can result in severe injury or death.

- Normal Operating Tire Pressure:
 - Front: 14psi (97kPa)
 - Rear: 14psi (97kPa)
- Maximum Load in Cargo Box:
 - Front: 14psi (97kPa)
 - Rear: 14psi (97kPa)
- Max. weight capacity: 1000lbs (458kg)

⚠️ CAUTION

- Use only 91 Octane or higher gasoline (E-10 max).
- Use Non-Ethanol gasoline when possible for better engine performance.
- NEVER USE E-85 gasoline, it will damage the engine and void the warranty.

⚠️ WARNING

EXHAUST FUMES MAY CAUSE HARM

Engine exhaust from this product contains chemicals, known in certain quantities to cause cancer, birth defects, or other reproductive harm.

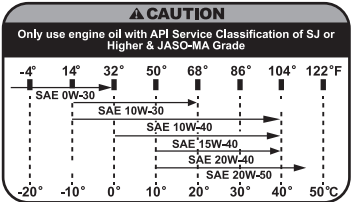
⚠️ WARNING

The battery contains or emits chemicals known in certain quantities to cause cancer, birth defects or other reproductive harm.

Instructions:

Preparing the battery for filling with electrolyte (acid):

- Take off the rubber sealing cap and remove filling plugs.
- Replace rubber cap with exhaust tube provided.
- Remove rubber cap.
- Connect exhaust tube.

Filling electrolyte (acid):

Fill battery with electrolyte (diluted sulphuric acid) with a specific Gravity of: cool or temperate climate 1.270-1.280
Tropical climate 1.250-1.260

The electrolyte temperature when filling must not be lower than 15°C or higher than 50°C.

Fill battery to upper level as indicated on the battery case.

Leave battery to stand for at least 30 minutes after filling. Electrolyte level may fall during this period, refill to upper level before charging.

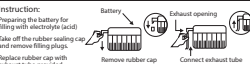

SAFE OPERATION PRACTICES

Before setting up and operating your new utility vehicle please locate the model plate and record the information in the provided area to the right. You can locate the model plate by looking on the frame above the left rear tire. See the image below. This information will be necessary, should you seek technical support via our web site, Customer Support Department, or with a local authorized service dealer.

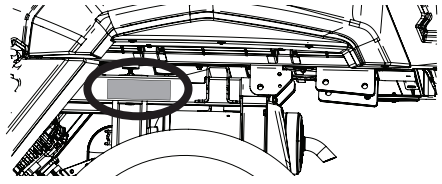

IMPORTANT NOTICE

This UTV is designed and manufactured for **OFF-ROAD** use only. It is illegal and unsafe to operate this UTV on any public street, road or highway.

This UTV complies with all applicable **OFF-ROAD** noise level and spark arrestor laws and regulations in effect at the time of manufacture.

Please check your local riding laws and regulations before operating this UTV.

When the temperature is below -4° F (-20° C), park the UTV in a place where the temperature is higher than -4° F (-20° C). Start the UTV after the UTV has warmed up. Please see the manual on the warming up process.

Follow the proper parking procedures when the temperature is higher than 100° F (38° C): turn off the engine; make sure the radiator fan is on for 3 minutes before turning off the power switch.

Starting the UTV for the first time will take longer because the fuel will need to reach the fuel injectors. To start the UTV the first time, hold the ignition key on at 5-second intervals. Allow the starter to rest 15 seconds between each start attempt.

UNIVERSAL SYMBOLS

As a guide to the operation of your vehicle, various universal symbols have been utilized on the instruments and controls. The symbols are shown below with an indication of their meaning.

	Warning/Danger/ Caution Symbol
	Fuel
	Engine Coolant -- Temperature
	Parking Brake
	Battery Charging Condition
	Engine Oil -- Pressure
	Turn Signal/Hazard
	Differential Lock
	Position Light Bulb

	Lift Cylinder -- Retract
	Lift Cylinder -- Extend
	Lift Cylinder -- Float
	Hazard Warning Lights
	Master Lighting Switch
	Audible Warning Device
	Fault Indicator Light of EPS System
	2WD/4WD

THANK YOU

Thank you for purchasing this product. It was carefully engineered to provide excellent performance when properly operated and maintained.

Please read this entire manual prior to operating. It instructs you how to safely and easily set up, operate and maintain your vehicle. Please be sure that you, and any other persons who will operate the vehicle, carefully follow the recommended safety practices at all times. Failure to do so could result in personal injury or property damage.

All information in this manual is relative to the most recent product information available at the time. Review this manual frequently to familiarize yourself with the vehicle, its features and operation. Please be aware that this Operator's Manual may cover a range of product specifications for various models. Characteristics and features discussed and/or illustrated in this manual may not be applicable to all models. We reserve the right to change product specifications, designs and vehicle without notice and without incurring obligation.

If applicable, the power testing information used to establish the power rating of the engine equipped on this vehicle can be found at www.opei.org or the engine manufacturer's web site.

If you have any problems or questions concerning the vehicle, phone your local authorized service dealer or contact us directly. We want to ensure your complete satisfaction at all times.

Throughout this manual, all references to right and left side of the vehicle are observed from the operating position.

PRE-START CHECK ITEMS

To better prevent or avoid unnecessary repairs, it is important to know the condition of the vehicle well. Check it before operating.

- | | | | |
|---|----------------------------------------------------------------|---|------------------------------------------------------|
| ✓ | Visually inspect the vehicle | ✓ | Check indicators, gauges and meters |
| ✓ | Check engine oil level | ✓ | Check lights |
| ✓ | Check air filter | ✓ | Check seat belts and roll-over protective structures |
| ✓ | Check brake fluid level | ✓ | Check front and rear joint boots |
| ✓ | Check coolant level | ✓ | Check tire inflation pressure |
| ✓ | Clean radiator screen (when used in dusty or muddy conditions) | ✓ | Check fuel |
| ✓ | Check brake and pedal | ✓ | Check danger, warning and caution labels |
| ✓ | Check parking brake | | |

CONTENTS OF CRATE

- Utility Vehicle (1)
- Operator's Manual (1)
- Tool Kit
- Product Registration Card (1)

NOTE: This Operator's Manual covers several models. Utility vehicle features may vary by model. Not all features in this manual are applicable to all utility vehicle models and the utility vehicle depicted may differ from yours.

NOTE: All references in this manual to the left or right side and front or back of the utility vehicle are from the operating position only. Exceptions, if any, will be specified.

NOTE: Some components may come already assembled. If they are already assembled, skip ahead to the next step.

CAUTION

To avoid personal injury: Be sure to check and service the vehicle on a level surface with the engine shut off, the parking brake "ON" and any attachments lowered to the ground.

OPERATION

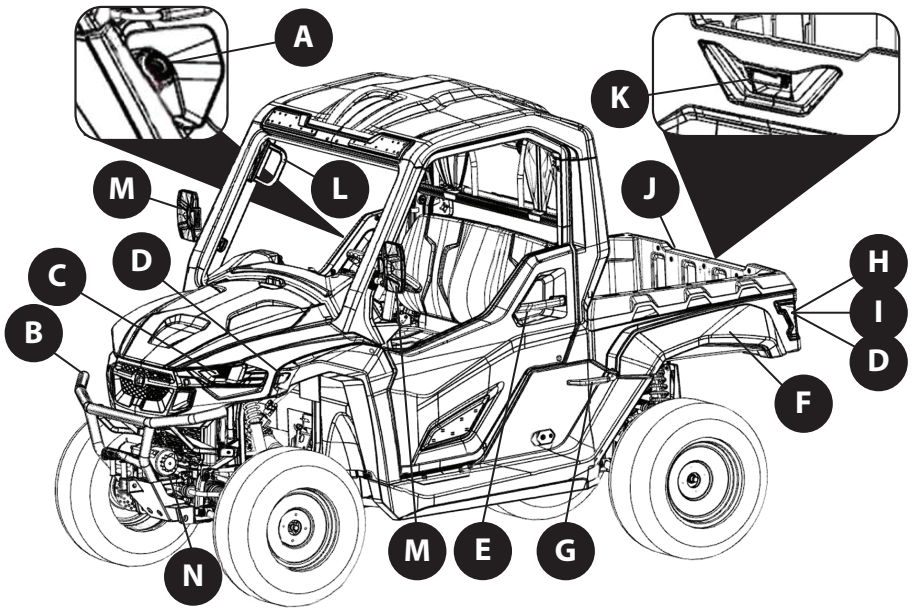

Figure 1

FEATURES

Refer to Figure 1 for the location of the features described below.

A. FUEL CAP

The fuel cap is located on the right side of the vehicle to the rear of the passenger door.

B. BUMPER

The bumper is located on the front of the utility vehicle.

C. HEADLIGHTS

The headlights are located on the front of the utility vehicle and are illuminated when the headlight switch is in the "ON" position.

D. TURN SIGNALS

The turn signals are on the front and rear of the vehicle and are activated by the turn signal switch.

E. DOOR HANDLES

The door handles are used to open the doors and are located on the doors.

F. CARGO BED

The cargo bed is used to haul materials and is located on the back of the utility vehicle. See the Specifications chart for information on cargo bed capacity and dimensions.

G. CARGO BED RELEASE LEVERS

The cargo bed release levers are located on both the RH and LH side of the cargo bed and are used to dump/tilt the cargo bed.

H. BRAKE LIGHTS

The brake lights are located on the rear of the cargo bed and are illuminated by depressing the brake pedal or when the hazard button is in the "ON" position.

I. TAIL LIGHTS

The tail lights are illuminated when the headlight switch is turned to the "ON" position.

J. TAILGATE

The tailgate is located on the rear of the cargo bed and can be opened by using the tailgate lever.

K. TAILGATE LEVER

The tailgate lever is located on the tailgate and is used to open the tailgate.

L. HAND GRIP

The hand grip is located on the passenger side of the utility vehicle on the OPS.

M. MIRRORS (OPTIONAL, IF EQUIPPED)

The mirrors are located on the passenger and driver's side of the vehicle and are used to see behind the utility vehicle.

N. WINCH

The winch is located on the front of the utility vehicle inside the bumper. The winch is controlled by the winch control.

OPERATION

OCCUPANT PROTECTION STRUCTURE (OPS) & SEAT BELTS (NOT SHOWN)

This utility vehicle is equipped with an Occupant Protection Structure (OPS) and seat belts. When used together they are effective in reducing crushing injuries to the operator and passenger in the event of an accidental rollover or tip-over. The safety provided by the OPS is minimized if the seat belt is not properly adjusted AND buckled. Adjust the seat belts for proper fit and connect the buckle. This seat belt is an auto-locking, retractable type.

To wear the 3-point seat belt properly:

1. Pull the seat belt latch down and across your chest toward the buckle. The belt should fit snugly across your hips and diagonally across your chest. Make sure the belt is not twisted.
2. Push the latch plate into the buckle until it clicks. Pull up on the strap to tighten.
3. Press the red release latch on the buckle to release the seat belt.

⚠ WARNING

Always wear the seat belt when operating the utility vehicle.

Use the following guidelines when using a utility vehicle equipped with OPS:

1. Be aware of overhead clearances in the area of operation. Check for clearance of door (or gate) openings and other overhead objects such as utility lines and tree branches. Overhead objects could catch the OPS and upset the utility vehicle.
2. Do not modify the OPS by drilling holes for, or welding accessories to, the structure.
3. Do not use the OPS to pull objects with the utility vehicle. Use ONLY the utility vehicle hitch for pulling.
4. Do not operate the utility vehicle without the OPS and do not remove the OPS.
5. In the event of an accident, have the OPS carefully inspected and, if necessary, replaced by your authorized dealer. Do not attempt to repair the OPS.

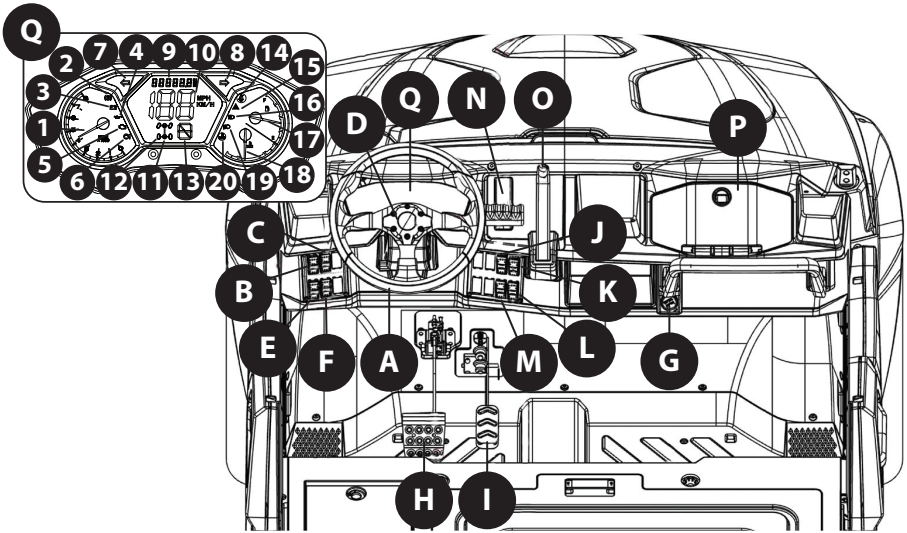

Figure 2

CONTROLS

Refer to Figure 2 for location and information of the controls described below.

A. STEERING WHEEL

The steering wheel is used to control the direction of the utility vehicle.

IGNITION (NOT SHOWN)

The ignition is located on the right side of the steering column.

B. HIGH BEAM SWITCH

The high beam switch is used to turn the high beams on the headlights "ON" and "OFF."



OPERATION

C. HEADLIGHT/TAIL LIGHT SWITCH

The headlight/tail light switch turns the headlights, instrument cluster lights and tail lights "ON" and "OFF."



D. HORN

The horn activates the horn under the hood when depressed.

E. HAZARD SWITCH

The hazard switch turns the hazards "ON" and "OFF."



F. TURN SIGNAL SWITCH

The turn signal switch controls the turn signals and activates the LH or RH turn signals.



G. 12V POWER OUTLET

The 12V power outlet is used for the convenience of plugging in accessories that require a power source with a maximum load of 5A at 12V.

H. BRAKE PEDAL

The brake pedal is used to slow down/stop the utility vehicle.

I. GAS PEDAL

The gas pedal is used to control the speed of the utility vehicle.

J. 2WD/4WD SWITCH

The 2WD/4WD switch is used to switch between 2WD and 4WD.



K. FRONT AXLE DIFFERENTIAL SWITCH

The front axle differential switch can "LOCK" or "UNLOCK" the front axle differential.

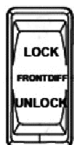

L. REAR AXLE DIFFERENTIAL SWITCH

The rear axle differential switch can "LOCK" or "UNLOCK" the rear axle differential.



M. WINCH CONTROL

The winch control releases cable on the winch ("OUT") or pulls the cable in ("IN").



N. SHIFT LEVER

The shift lever changes the gears of the utility vehicle between park ("P"), reverse ("R"), neutral ("N"), high ("H") and low ("L").



O. PARKING BRAKE LEVER

The parking brake lever activates the utility vehicle's parking brake.

P. GLOVE BOX

The glove box is a small storage area in the dash on the passenger side of the utility vehicle.

Q. INSTRUMENT CLUSTER

The instrument cluster contains:

- 1 - TACHOMETER
- 2 - PARKING BRAKE INDICATOR
- 3 - BATTERY INDICATOR
- 4 - OIL PRESSURE INDICATOR
- 5 - ENGINE INDICATOR
- 6 - EPS SYSTEM FAULT *
- 7 - LEFT TURN SIGNAL
- 8 - RIGHT TURN SIGNAL
- 9 - HOUR METER
- 10 - SPEEDOMETER
- 11 - DIFFERENTIAL LOCK INDICATOR
- 12 - 2WD/4WD INDICATOR
- 13 - GEAR INDICATOR
- 14 - SEAT BELT INDICATOR
- 15 - HAZARDS
- 16 - HIGH BEAM INDICATOR
- 17 - FUEL GAUGE
- 18 - COOLANT TEMPERATURE
- 19 - LOW BEAM INDICATOR
- 20 - COOLANT OVER-TEMP INDICATOR

* -- If equipped

OPERATION

First 50 Hours

How a new vehicle is handled and maintained determines the life of the vehicle.

A new vehicle just off the factory production line has been, of course, tested, but various parts are not fully aligned, so the operator should pay more attention to operating the vehicle for the first 50 hours at a slower speed and avoid excessive work or operation until the various parts become "broken-in." The manner to which you handle the vehicle during the "breaking-in" period greatly affects the life of your vehicle. Therefore, to obtain the maximum performance and the longest life of the vehicle, it is very important to properly break-in your vehicle. For better handling a new vehicle, the following precautions should be observed.

- Do not operate the vehicle at full speed for the first 50 hours.
- Do not start quickly nor apply the brakes suddenly.
- In winter, operate the vehicle after fully warming up the engine.
- Do not run the engine at speeds faster than prescribed.
- On rough roads, slow down to suitable speeds.
- Do not operate the vehicle at fast speed.

The above precautions are not limited to new vehicles. However, they should be especially observed for new vehicles.

NOTE: The lubricating oil is especially important for a new vehicle. Various parts need time to wear and polish themselves to the correct operating clearances. Small pieces of metal grit may develop during the operation of the vehicle; and this may wear out or damage the parts. Therefore, change the lubricating oil a little earlier than would ordinarily be required. For further details of change interval hours, see the Product care section of this manual.

Starting the Utility Vehicle

WARNING

Seat belts reduce injury. Always wear your seat belts. The lap-style seat belts may not provide adequate protection for small children. Pay special attention when carrying a child passenger. Always use the seat belts when operating and riding in the vehicle.

GENERAL SAFETY

- **RECEIVE INSTRUCTION** — Entirely read this operator's manual. Learn to operate this vehicle SAFELY. Do not risk INJURY or DEATH. Allow only those who have become competent in its usage to operate this utility vehicle.
- Before starting the engine or beginning operation, be familiar with the controls.

- Read the danger, warning and caution labels located on the vehicle.
- To avoid the danger of exhaust fumes, do not operate the utility vehicle in closed buildings without proper ventilation.
- Start engine only from operator's seat. Never start the engine while standing outside the utility vehicle.
- Make sure the shift lever is in the NEUTRAL (N) or PARK (P) position before starting the engine.

STARTING THE ENGINE

NOTE: Do not use starting fluid or ether.

NOTE: To protect the battery and the starter, make sure that the starter is not continuously turned for more than 5 seconds.

1. Engage the parking brake.

NOTE: The parking brake indicator is illuminated when the parking brake is applied and turns off when it is released (Figure 2).

2. Place the shift lever in the NEUTRAL (N) or PARK (P) position.

NOTE: The engine will not start without the gear shift in the NEUTRAL (N) or PARK (P) position and the brake depressed.

3. Insert the key into the ignition and turn it to the START position. Release the key when the engine starts (Figure 3).

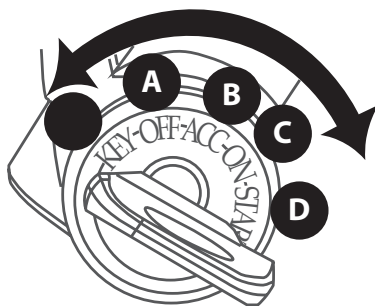

Figure 3

NOTE: The ignition is a 4-position switch, the positions and brief descriptions of each are below:

- a. OFF — Engine is off and the key can be removed.
- b. ACC — Accessories such as radio are on, but engine is off.
- c. ON — Engine and all accessories are on.
- d. START — Starter motor on, the key will return to the ON position when released.

NOTE: When the ambient temperature is below -15°C (5°F), the engine is very cold. If the engine fails to start after 5 seconds, turn off the key for 30 seconds and start again.

Stopping the Engine

1. After slowing the engine to idle, turn the key to the OFF position.
2. Remove the key.

Warming Up

⚠ CAUTION

Be sure to set the parking brake during warm-up. Be sure to set the shift lever to the PARK position during warm-up.

For 5 minutes after engine start-up, allow the engine and transmission to warm up without applying any load. This is to allow oil to reach every engine part. If load applied to the engine or transmission without warming up, damage may occur.

Driving the Utility Vehicle

1. Adjust the seat belt to fit comfortably around your lap, then buckle the seat belt.

⚠ WARNING

Do not operate the vehicle without the OPS in place and the seat belt fastened securely around your waist and chest.

2. Start the engine as instructed in the Starting the Engine section and make sure the front wheels are turned to the desired direction of travel.

⚠ CAUTION

Immediately stop the engine if the engine suddenly slows down or accelerates, unusual noises are suddenly heard, or exhaust fumes suddenly become very strong.

3. Push down on brake pedal, pull slightly back on the parking brake lever while depressing the lock button and then slowly push forward to release the parking brake.
4. Push down on brake pedal and move the shift lever into the desired setting. To avoid damaging the transmission, depress the brake pedal fully and make sure the vehicle is completely stopped before shifting into HIGH (H), LOW (L) or REVERSE (R).

⚠ WARNING

Do not stop or start suddenly when going uphill or downhill. Be cautious when changing direction on slopes. Apply brakes when going down slopes to maintain control of vehicle.

5. Release brake pedal and slowly apply pressure to the gas pedal.
6. Release gas and apply brake pedal evenly and firmly to slow down or stop.

2WD/4WD

⚠ CAUTION

When traveling at road speed, use only 2WD. When driving on icy, wet, or loose surfaces, make sure the vehicle is correctly loaded to avoid skidding and loss of steering control. Reduce the speed and engage front wheel drive. Accident may occur if the vehicle is suddenly braked, such as heavy towed loads shifting forward causing loss of control. The braking characteristics are different between two and four wheel drive. Be aware of the differences and operate carefully.

To activate the 4WD stop the utility vehicle and press down on the upper half of the 2WD/4WD switch. To return to 2WD, stop the utility vehicle and press down on the lower half of the 2WD/4WD switch. When in 2WD just the two rear tires will be filled on the instrument cluster indicator, when in 4WD all four tires will be filled (Figure 4).

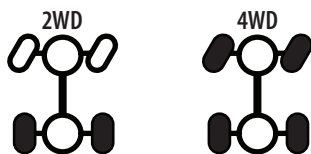

Figure 4

Differential Lock

⚠ WARNING

To avoid transmission damage, injury, or turf damage, drive slow when operating utility vehicle with differential lock engaged as steering response is noticeably reduced. Also, do not drive the utility vehicle with the differential lock engaged on concrete, asphalt, or any high traction surfaces.

The front and rear axle differentials can be activated when the utility vehicle is stopped and the shift lever is in the NEUTRAL position. To activate either axle differential press the upper portion of the front/rear axle differential switch. To deactivate the axle differential press the lower portion of the front/rear axle differential switch. Both, one or neither of the differentials can be active. When activated the differential lock indicator display will show an "X" on the indicator as shown in Figure 5.

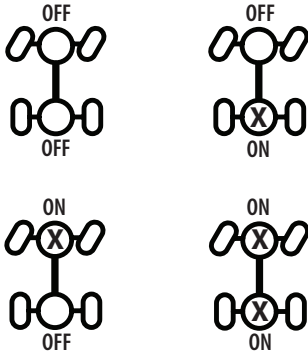

Figure 5

IMPORTANT! Engage the differential as the last option when stuck in mud or similar situation or when the left and right side wheels are turning at slightly different speeds.

Loading the Cargo Bed

⚠ WARNING

The utility vehicle may become unstable if the cargo bed is loaded incorrectly. Avoid loose and unsecured loads or uneven loading of material.

1. Verify cargo bed is securely latched before loading.
2. Securely anchor all loads in cargo bed and do not load beyond maximum capacity.

NOTE: The maximum box capacity is 500 lb (227 kg).

3. When loading objects into cargo bed, be sure load is securely anchored and evenly distributed.
4. Do not load above height of cargo bed. Load could shift forward striking driver or passenger or cause driver to lose control of vehicle.
5. Avoid loads which exceed physical dimensions of cargo bed.
6. Avoid concentrated loads at rear or sides of cargo bed. Be sure load is distributed evenly.
7. Reduce load and ground speed when operating over rough or hilly terrain. Do NOT overload vehicle. Limit loads to those that can be safely controlled.

Raising & Lowering the Tailgate

To open up the tailgate (a), pull up on the tailgate lever (b) and slowly lower the tailgate (a). To close the tailgate (a) lift the tailgate (a) and push it forward until it locks into place (Figure 6).

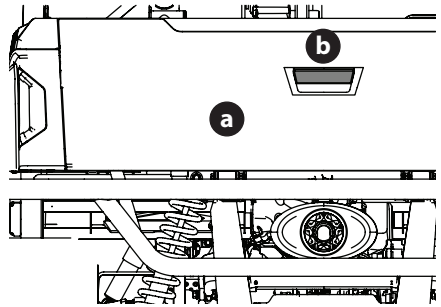

Figure 6

Raising & Lowering the Cargo Bed (Dumping Load)

⚠ WARNING

To prevent the possibility of bodily injury from unintentional lowering of the cargo bed, be sure vehicle is on a level and stable surface and parking brake is set before raising cargo bed.

⚠ WARNING

A loaded cargo bed can be very heavy. Do not attempt to dump a heavily loaded cargo bed.

Park the vehicle safely on level ground and set parking brake.

1. Empty heavy loads by hand.
2. For light loads, unlatch cargo bed by pulling up on one of the cargo bed release levers. While holding the cargo bed release lever lift the cargo bed (Figure 7).

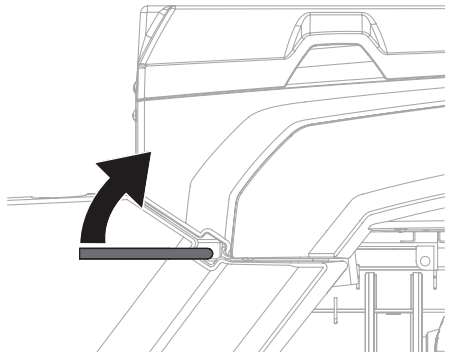

Figure 7

OPERATION

- Once unloaded, lower the cargo bed and securely latch it before operating the utility vehicle. Do not drive the utility vehicle with cargo bed in the raised position.

Towing Loads

WARNING

To help prevent personal injury due to loss of control or tipping, always tow a load slow enough to maintain control.

- Do not tow a load that exceeds 1200 lb (544 kg) rolling weight (i.e. trailer plus cargo) and never exceed 110 lb (50 kg) tongue weight.
- Go slow when towing a heavy load. Allow for increased braking distance. Tow load at a speed slow enough to maintain control.
- Do not tow on slopes greater than 5°.
- Be cautious when towing downhill, even on a gradual slope or when turning. The extra weight tends to push the tow vehicle and may cause you to lose control (braking and steering ability are reduced; towed equipment may jack-knife).

IMPORTANT! Extreme angles such as high railroad crossings can place high bending loads on hitch connection.

- Do not modify the hitch in any way.

Loading a Utility Vehicle into a Truck or onto a Trailer

WARNING

Always park the truck or trailer in a flat area, set the parking brake, turn the ignition off, and chock the wheels to prevent any unexpected movement while loading the utility vehicle.

WARNING

Fully secure the loading ramps to the truck or trailer with tie-down straps or cables to prevent the ramps from sliding off while loading. Keep bystanders and/or helpers away from ramps while loading.

Due to the overall size and dimensions, loading a utility vehicle into a truck or onto a trailer is a task that requires precision and the proper equipment to be achieved safely. By following the steps outlined below you'll be able to select the proper equipment to do the job and safely load and unload your utility vehicle.

DETERMINE IF YOUR TRUCK OR TRAILER IS SUFFICIENT FOR THE TASK

Loading a utility vehicle into a truck or trailer that can't support its weight is extremely dangerous. It is important that before any actual loading is done, make sure your truck or trailer and loading ramps are sufficient for loading and hauling the utility vehicle. Here are some of the variables you need to take into account:

- Length and Width:** Measure the size of your truck or trailer by taking width and length measurements at the floor level. Compare these measurements to the width and length of your utility vehicle to make sure it will fit comfortably.
- Weight Capacity:** Making sure your truck or trailer can handle the payload of your utility vehicle is another critical task before any loading is done. If using a truck, the payload capacity must be a minimum of 3/4 ton. If hauling on a trailer, remember that the towing capacity of the vehicle will be reduced by the added weight of the utility vehicle.
- Tailgate Considerations:** If the payload capacity is sufficient for hauling in a truck, the last thing left to consider is your truck's bed length. Make certain that your truck bed is long enough to allow the truck's tailgate to close completely when the utility vehicle is loaded into the truck bed.

CHOOSING THE PROPER LOADING RAMP(S)

Choosing a reliable ramp and understanding how to properly use it is far and above the best option for safely loading a utility vehicle into your truck or onto your trailer. Take a look at the considerations you should have in mind when choosing the proper ramp(s):

- Capacity:** Utility vehicles are not evenly balanced, meaning it's necessary to check the axle weights before you make any choices regarding ramps. A typical ramp's capacity is based upon two axles with equally distributed loads. We recommend 3000-lb minimum capacity ramp(s) as the appropriate option for your two-person utility vehicle.
- Offset Track Widths:** Your utility vehicle has an offset track width front and rear, it's important to factor this in to your ramp placement and ramp width needs. Ramps need to be wide enough to accommodate the difference in the distances between the front two wheels and the rear two wheels.
- Ground Clearance and Wheelbase:** Utility vehicles which have low ground clearance (under 4") and a relatively long wheelbase (98" or more), make them prone to bottoming out at the crest when using straight ramps. As a solution to this issue we suggest using arched ramps.
- Load Height:** As with any ramp application, the distance from the ground to the truck bed or trailer impacts the overall length of the ramp you will need, the greater the load height, the longer the ramp should be. Some ramp manufacturers and retailers provide load height calculators to help you determine the correct ramp length you will need to safely load your vehicle.

NOTE: If you are still unsure of what types of ramps you will need to get the job done and are having trouble understanding these instructions, check with your local ramp or utility vehicle retailer for assistance.

OPERATION

LOADING THE UTILITY VEHICLE

If your truck or trailer's load capacity is sufficient to transport the utility vehicle and you obtain the proper loading ramps and equipment to safely secure the utility vehicle to the truck or trailer, the only thing left to do is load it. Here's how to best accomplish this task:

1. Proceed with extreme caution. It is very difficult to overcome a mistake while in the loading process.
2. Park the truck or trailer in a flat area, set the parking brake, turn the ignition off and chock the wheels.
3. Face the truck bed or trailer towards a slight incline, which will reduce the steepness of the loading angle by bringing the bottom of the ramps up on the slight incline (Figure 8).

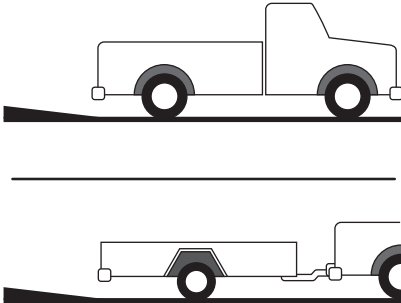

Figure 8

4. Place the ramp fingers or plate edges on the edge of the trailer or truck bed (Figure 9).

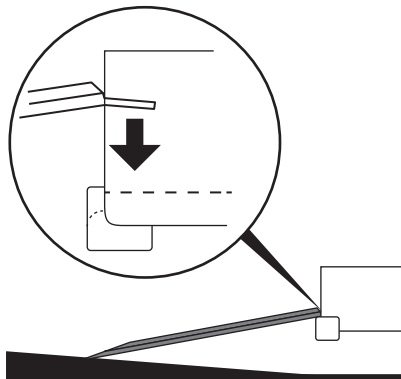

Figure 9

5. Use tie-down straps or cables to secure the ramps to the trailer or truck, via the bumper (steel bumpers only) or trailer hitch safety chain loops. Refer to instructions provided with the ramp.
6. If your utility vehicle is supplied with a roof and/or windshield, remove or fully secure them prior to loading. Roofs and windshields are not designed to withstand the wind speeds that the open road can generate, so it's best to remove them entirely to prevent any damage or accidents.
7. Follow all safety rules provided in this manual along with the manuals supplied by the trailer and ramp manufacturer. Carefully load the utility vehicle onto the truck or trailer.
8. Once the utility vehicle is on the truck or trailer, set the utility vehicle's parking brake and secure the utility vehicle to the truck or trailer. Tie-down strap placement will depend on your truck or trailer. Be sure to use only tie-down straps sufficient for the load capacity. If loaded onto a truck, close the tailgate once the utility vehicle is secured to the truck bed.
9. Stop periodically to ensure that your tie-down straps have not loosened and that the utility vehicle remains securely in place.

IMPORTANT! Know the total height of your vehicle with the utility vehicle loaded before transporting. Be sure to check for low clearance bridges, doorways, etc. prior to traveling under them. The added height above the height of your truck could cause clearance issues and damage to both vehicles.

PRODUCT CARE

MAINTENANCE CHART

WARNING

Before performing any type of maintenance/service, disengage all controls and stop the engine. Wait until all moving parts have come to a complete stop. Disconnect spark plug wire and ground it against the engine to prevent unintended starting. Always wear safety glasses during operation or while performing any adjustments or repairs.

Follow the Maintenance Chart given below. This chart describes service guidelines only. Refer to the Engine Operator's Manual for engine maintenance items listed in the table below.

	First 20 hours	First 50 hours	Every 50 hours	Every 100 hours	Every 150 hours	Every 200 hours	Every 300 hours	Every 500 hours	Every 3900 hours	Every year	Every 2 years	Every 4 years
Grease utility vehicle		✓										
Clean muffler/spark arrestor		✓		✓								
Clean spark arrestor			✓									
Check lug nuts		✓		✓								
Check battery condition				✓								
Adjust front wheel toe-in				✓								
Change oil	✓			✓						✓		
Check fuel line				✓								
Replace fuel line	✓							✓				
Clean air filter element*				✓						✓		
Check brake pedal		✓				✓						
Adjust parking brake		✓				✓				✓		
Check brake light switch		✓				✓						
Check radiator hose & clamp						✓						
Replace radiator hose & clamp											✓	
Check PCV Accumulator		✓			✓							
Check intake air line						✓						
Replace intake air line											✓	
Check brake hose & pipe		✓			✓							

PRODUCT CARE

	First 20 hours	First 50 hours	Every 50 hours	Every 100 hours	Every 150 hours	Every 200 hours	Every 300 hours	Every 500 hours	Every 3900 hours	Every year	Every 2 years	Every 4 years
Replace brake hose & pipe												✓
Check tires	✓						✓					
Change axle case oil							✓					
Adjust engine valve clearance								✓				
Check fuel injection								✓				
Check injection									✓			
Check CV shaft boots			✓									
Check exhaust system					✓							
Check wheel bearings	✓				✓							
Check engine timing							✓					
Change brake fluid											✓	
Replace remote hydraulic hose											✓	
Replace rear brake cylinder seal											✓	
Replace front brake cylinder seal											✓	
Flush cooling system											✓	
Change engine coolant											✓	

* -- Have this item performed by an authorized service dealer
 # -- Perform more often in dry conditions and/or when mulching

PRE-START CHECKLIST

- Check parking brake. Make sure the parking brake indicator light comes on when the parking brake is ON.
- Inspect the instrument panel for broken gauges and warning lamps.
- Check the headlights and turn signals. Replace if broken.
- Check seat belt and OPS. Do not operate utility vehicle until repaired if either is broken.
- Check the joint boots on the drive shaft for damage. If the joint boots are damaged, see an authorized service dealer.
- Check tire pressure. See Tire Pressure in this section.

MAINTENANCE

⚠ WARNING

To avoid personal injury, be sure to check and service the vehicle on a flat surface with the engine off and the parking brake ON. If servicing under the cargo bed, be sure that the cargo bed is supported so that it can not inadvertently close. Do not touch muffler or exhaust pipes while they are hot; Otherwise, severe burns could result.

⚠ WARNING

If vehicle diagnosis requires the vehicle to be run with the wheels off the ground, the free wheeling state will cause the engine management system to create a lean condition. This lean condition will cause the exhaust system to become hotter than normal operating conditions. Exercise extreme caution when working around the exhaust components and allow extra time for the exhaust components to cool.

Tire Pressure

The recommended operating tire pressure is 14 psi (70 kPa) for all tires. Over-inflating above recommended tire pressure can reduce the life of the tire. Check tire pressures before each use.

NOTE: If the cargo bed is at maximum capacity (1000 lbs), the rear tire pressure can be increased to 18 psi (124 kPa).

Lug Nuts

1. Check torque of lug nuts after first 50 hours of use and every 100 hours thereafter. Tighten lug nuts in a diagonal pattern. Torque lug nuts to 65-75 lb-ft using a torque wrench.

Removing the Hood & Interior Hood Panel

⚠ CAUTION

To avoid personal injury from contact with moving parts never open operator's seat or hood cover while the engine is running.

To open the hood, pull up on the center of the upper edge of the cover (a) and lift the hood off. To close, insert the front bottom hooks into the hood. Push down on the perimeter of the cover (Figure 10).

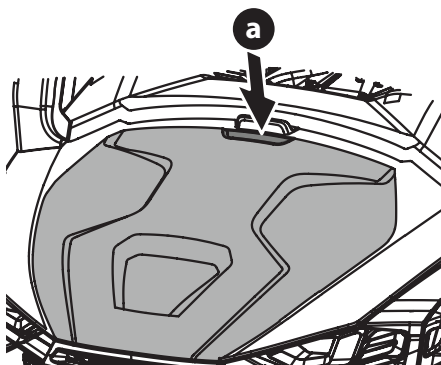

Figure 10

To remove the interior hood panel (a), grasp the upper left corner of the panel and pull (Figure 11).

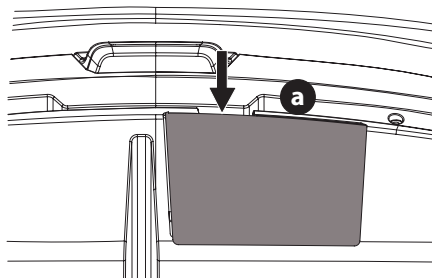

Figure 11

Removing the Seat

To remove the seat, lift up on the front edge of the seat and after the two pins (a) clear the bushings pull towards the front of the vehicle (Figure 12). When re-installing the seat, make sure the pins (a) in the seat are inserted into the holes (b) in the frame.

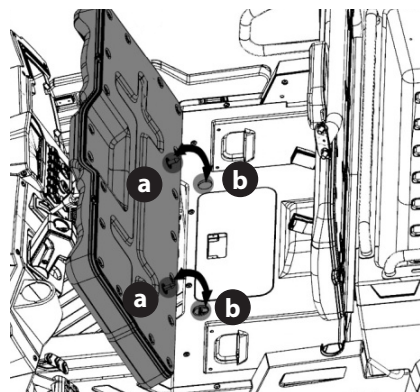

Figure 12

Removing the Battery Access Panel

Unlock the battery access panel under the seat by rotating the lock knob, then lifting the battery access panel (Figure 13).

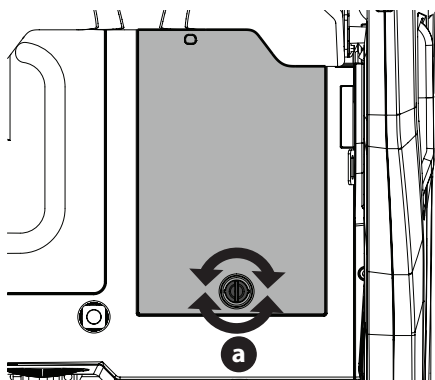

Figure 13

Removing the Engine Access Panel

Lift up on the handle (a) near the front of the engine access panel under the seat, then remove the engine access panel (Figure 14).

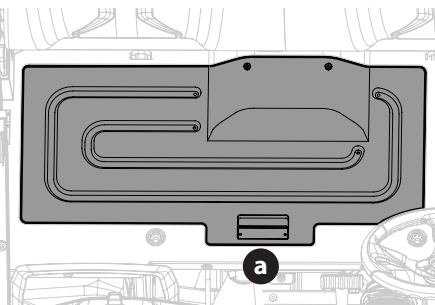

Figure 14

Removing the Air Filter Access Panel

Remove the two screws (a) securing the air filter access panel (b) to the front of the seat box (Figure 15).

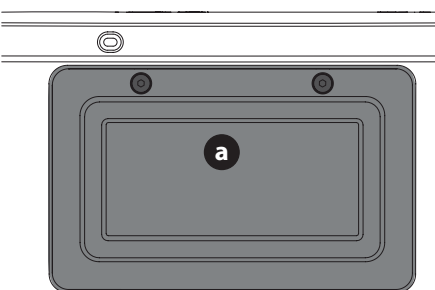

Figure 15

Jacking Up the Utility Vehicle

⚠ WARNING

To avoid personal injury, death, or vehicle damage do not work under the vehicle unless it is secured by safe stands or suitable blocking.

1. Jack up the front end of the utility vehicle on the front frame tube (a) only (Figure 16).

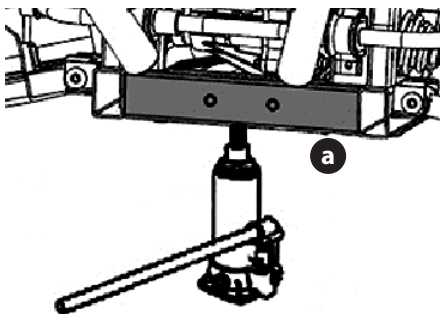

Figure 16

2. Jack the rear of the utility vehicle only after placing a wooden block under the right (a) and left frame tube (b) for securing the engine and then supporting it. Do not apply jack pressure on the steel plate directly under the engine (Figure 17).

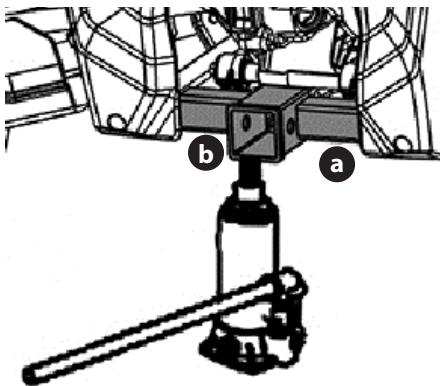

Figure 17

Adjusting the Doors

If the gaps around the doors are uneven, the door can be adjusted. To adjust the doors, loosen the two bolts (a) on each hinge, adjust the door until an equal gap is achieved all the way around. Retighten all four bolts (a) (Figure 18 on page 21).

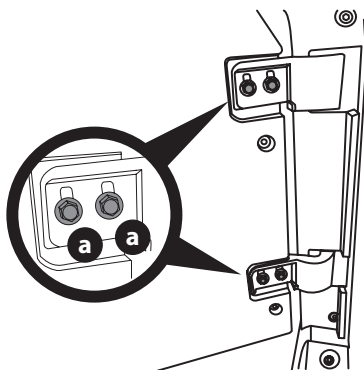

Figure 18

If the door is not latching properly, the latches (a) can be adjusted. Loosen the two bolts (b) securing the latch (a), position the latch (a) so that the door closes and latches properly, then re-tighten the two bolts (b) (Figure 19).

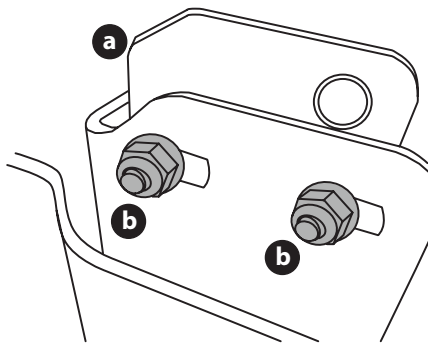

Figure 19

Checking & Refilling Fuel

⚠ CAUTION

Do not smoke while refueling. Be sure to stop the engine before refueling.

1. Turn the key switch to ON, check the amount of fuel by the fuel gauge.
2. Fill fuel tank when fuel gauge shows 1/4 or less fuel in the tank.
3. The fuel tank holds approximately 7.4 gallons (28 L) of fuel.

Checking & Adding Oil

IMPORTANT! If oil level is low, do not run the engine.

1. Park the vehicle on a flat surface with engine off, remove the seat and engine access panel to access the engine.

2. To check the oil level, remove the dipstick (a), wipe it clean, replace it without re-threading the dipstick, and pull it out again, check to see if the level is too low and add new oil to the full level on the dipstick (a) (Figure 20). For the location of dipstick.

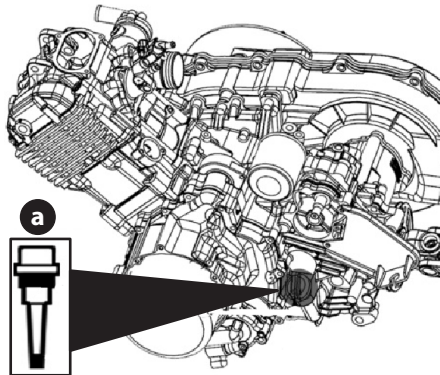

Figure 20

3. After the new filter has been replaced, the engine oil normally decreases a little. Make sure that the engine oil does not leak through the seal and check the oil level on the dipstick. Add oil if necessary.
4. See Figure 21 for oil recommendations.

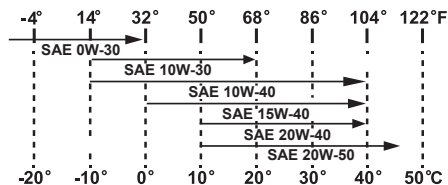

Figure 21

⚠ CAUTION

Only use engine oil with API Service Classification of SJ or Higher and JASO-MA Grade.

5. The engine oil capacity is 2.22 quarts (2.1 L).

Checking & Adding Engine Coolant

⚠ CAUTION

Do not remove radiator cap while coolant is hot. When cool, slowly rotate to the first stop and allow sufficient time for excess pressure to escape before removing the cap completely.

1. Park the vehicle on a flat surface, remove the hood panel, set the parking brake and shut off the engine.

2. Check to see that the coolant level is between the FULL (a) and LOW (b) marks of recovery tank (c) (Figure 22).

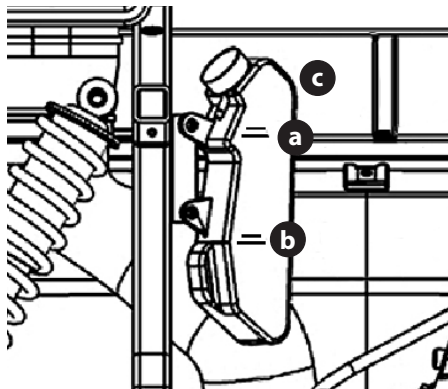

Figure 22

3. When the coolant level drops due to evaporation, add water only up to the FULL (a) level. In case of leakage add anti-freeze and water in the specified mixing ratio up to the FULL (a) level. (See Flushing the Coolant System & Changing Coolant section).

- Use clean fresh water and anti-freeze to fill the recovery tank.
- If water should leak, consult your local authorized service dealer.

NOTE: If the radiator cap has to be removed, follow the cautions above and securely retighten the cap.

Cleaning the Radiator Screen

⚠ CAUTION

Be sure to stop the engine before removing the screen.

NOTE: Radiator screen must be cleaned of debris to prevent engine from overheating.

1. Park the utility vehicle on a flat surface.
2. Remove the radiator cover.
3. Detach the screen and clean the radiator and radiator screen and radiator fins of all debris (Figure 23).

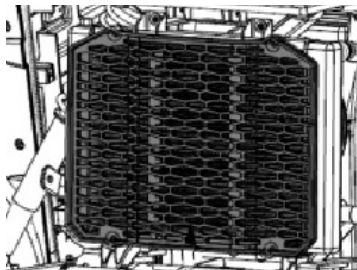

Figure 23

Checking & Adding Brake Fluid

⚠ CAUTION

Never operate the vehicle if the brake fluid is below the minimum mark. Use only DOT3 from a sealed container. Other types of brake fluid may ruin synthetic resin or rubber installed in brake system components and may cause brake failure. Avoid contamination of the brake fluid, thoroughly clean around the filler cap before removing. Do not open the brake fluid reservoir cap unless absolutely necessary. Use extreme care when filling the reservoir. If brake fluid spills on coolant hose, wash off with water immediately, as brake fluid quickly ruins synthetic resin or rubber hoses.

1. Check to see that the brake fluid level of the brake fluid reservoir (a) is up to the MIN (b) level (Figure 24).

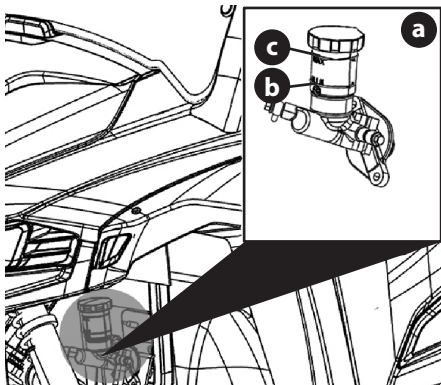

Figure 24

2. If it is below the MIN (b) level add brake fluid, but do not exceed the MAX (c) level.

Checking the Brake Pedal

⚠ WARNING

Stop the engine and chock the wheels before checking brake pedal.

Inspect the brake pedals for free play (a), pedal stroke (b) and smooth operation (Figure 25).

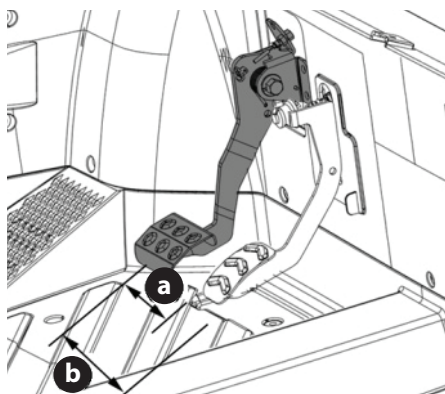

Figure 25

1. Release the parking brake.
2. Step on the pedal and measure the free play (a). There should be between .3" and .5" (7-14 mm) of free play (a). If the free play (a) measurement is outside of these specifications, see an authorized service dealer to have the brake adjusted.
3. Step on the pedal and measure the stroke (b). There should be less than 4.7" (120 mm) of stroke (b). If the measurement is outside of these specifications, see an authorized service dealer to have the brake adjusted.

Checking & Adjusting the Parking Brake

Pull the parking brake to apply the brakes with the key switch in the ON position and the parking brake indicator should come on. To release the parking brake, depress the parking pedal. Make sure the parking brake warning lamp on the display goes off when parking brake is OFF.

If the parking brake is in need of adjustment, proceed as follows:

1. Locate the parking brake adjustment nut near the engine (Figure 26).

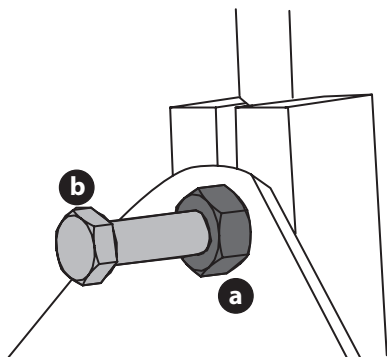

Figure 26

2. Loosen the lock nut (a) and then tighten the bolt (b) to adjust the parking brake. Turn the bolt until it touches, then back it off a 1/4-turn (Figure 26).

If there is play in the parking brake handle there is a secondary adjustment that can be performed.

1. Look inside the driver's side wheel well and locate the adjustment point. Slide back the rubber cover (a) on the adjustment nuts (b) (Figure 27).

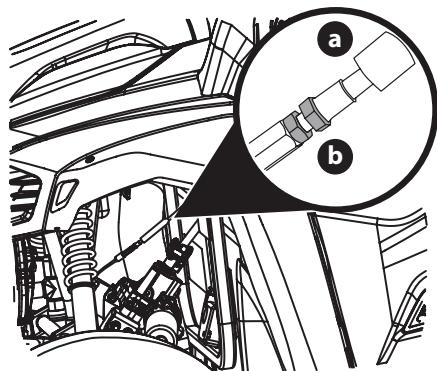

Figure 27

2. Adjust the parking brake handle nuts (b) until the free play in the handle is gone (Figure 27).

Checking & Adjusting the Shift Lever

If the shifter and the display image on the instrument cluster do not match or the utility vehicle is not shifting, a shift cable adjustment can be performed.

1. Remove the hood and the interior hood panel.
2. Locate the shift lever adjustment nuts (a) (Figure 28).

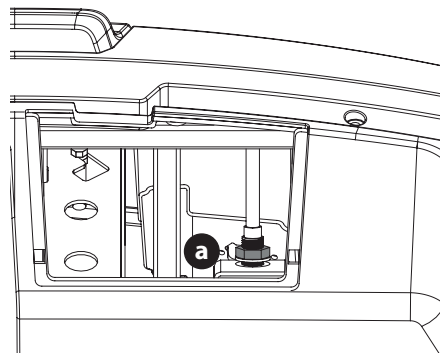

Figure 28

3. Adjust the nuts (a) up or down until the shift lever is working properly (Figure 28).

Checking the Engine Start System

WARNING

Do not allow anyone near the vehicle while testing. If the vehicle does not pass the test, do not operate the vehicle.

1. Sit on the operator's seat.
2. Place the shift lever in the NEUTRAL position.
3. Set the parking brake and stop the engine.
4. Move the shift lever to: LOW, HIGH, PARK or REVERSE position. Do not step on the brake pedal.
5. Turn the key to START position.
6. The engine should not crank.
7. If it cranks see an authorized service dealer.
8. Repeat Steps 4 and 5 but when turning the key to start position step on the brake pedal. The engine should crank.
9. If it does not crank see an authorized service dealer.

Adjusting the Shocks

There are three adjustment points on the shocks. The rebound (a), pre-load spring (b) and damping rate (c) can be adjusted. Refer to Figure 29 for the following instructions.

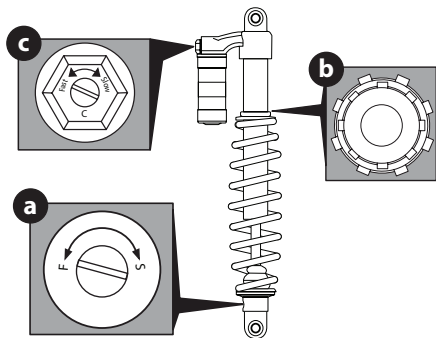

Figure 29

REBOUND ADJUSTER (A)

The rebound adjuster is located near the bottom of the shock and controls the "bounce back" speed of the utility vehicle. To adjust the rebound or "bounce-back" speed, follow the steps below:

NOTE: Each position has a stop or "click" to indicate the setting.

1. Insert a standard screw driver into the adjustment.
2. Rotate the screw into one of the 18 positions between "S" (position 0) and "F" (18). Rotate the screw clockwise (towards the "S" or "0" position) to slow the rebound and counter-clockwise (towards the "F" or "18" position) to speed up the rebound.

PRE-LOAD SPRING ADJUSTER (B)

The pre-load adjuster is located in the body of the shock and controls the height of the vehicle. It can be adjusted to accommodate for different load situations.

NOTE: This adjustment requires a spanner wrench to complete. A spanner wrench is included in the tool kit shipped with this utility vehicle.

1. Using a spanner wrench, loosen the upper lock nut.
2. Adjust the pre-load adjuster nut to the desired setting. Turn the pre-load adjuster clockwise to increase the compression force (raise the utility vehicle) and turn the pre-load adjuster nut counter-clockwise to decrease the compression force (lower the utility vehicle).

DAMPING RATE ADJUSTER (C)

The compression adjuster is located on the upper part of the shock and controls the ride of the utility vehicle and the impact resistance of the shocks.

NOTE: Each position has a stop or "click" to indicate which of the 18 positions it is in.

1. To increase the stiffness of the suspension and increase the absorption of impacts, rotate the compression adjuster screw clockwise towards the "SLOW" (or "0") position.
2. To decrease the stiffness (soften the ride) rotate the compression adjuster screw counter-clockwise towards the "FAST" (or "18") position.

To return the utility vehicle to its stock setting, use the chart below:

	Rebound Adjuster	Pre-Load Adjuster	Compression Adjuster
Front	Position 7	295 mm	Position 5
Rear	Position 4	300 mm	Position 3

* -- These settings are based on a "full load" condition. 250 lb (113 kg) driver, 250 lb (113 kg) passenger and 500 lb (227 kg) cargo load.

SERVICE

WARNING

To avoid personal injury, be sure to check and service the vehicle on a flat surface with the engine off and the parking brake ON. If servicing under the cargo bed, be sure that the cargo bed is supported so that it can not inadvertently close. Do not touch muffler or exhaust pipes while they are hot; Otherwise, severe burns could result.

Changing the Oil

⚠ WARNING

Be sure to stop the engine before replacing oil. Allow engine to cool down sufficiently, oil can be hot and can burn.

1. Park the vehicle on a flat surface and raise the cargo bed.
2. To drain the used oil, remove the drain plug at the bottom of the engine and completely drain the oil into an oil pan.
3. After draining, reinstall the drain plug.
4. Fill with the new oil up to the upper notch on the dipstick.
5. See Figure 30 for oil recommendations.

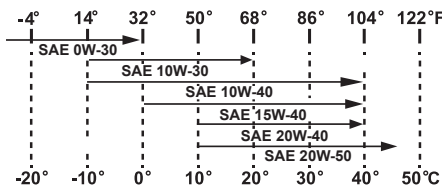

Figure 30

⚠ CAUTION

Only use engine oil with API Service Classification of SJ or Higher and JASO-MA Grade.

6. The engine oil capacity is 2.22 quarts (2.1 L).

Replacing Oil Filter

⚠ WARNING

Be sure to stop the engine before replacing oil filter. Allow engine to cool down sufficiently, oil can be hot and can burn.

1. Park the vehicle on a flat surface, remove the seat and open the engine access cover.
2. Make sure the engine is warm.
3. Remove the oil filter (a) (Figure 31).

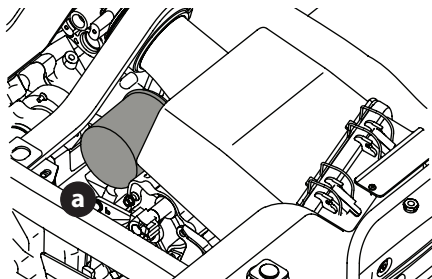

Figure 31

4. Put a film of clean engine oil on the rubber seal of the new filter.
5. Tighten the filter until it contacts the mounting surface.
6. Tighten filter by hand an additional 1/2-turn only.

Draining the PCV Accumulator

The PCV accumulator should be drained at each oil change to remove oil condensation. There are two PCV accumulators, one near the front of the air intake box and one near the rear. To drain the PCV accumulator, pinch the valve at the bottom of the tube and allow the condensation to run out (Figure 32).

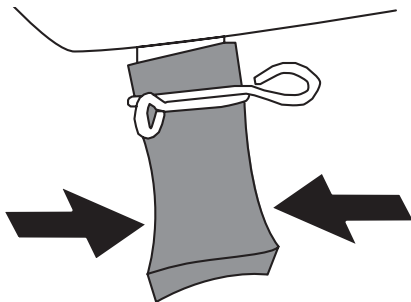

Figure 32

Replacing Mini Fuses

The mini fuses are intended to protect the electrical system. If any of them have blown out, be sure to pinpoint the cause. (See Specifications section, Figure 46 on page 37 for fuse box layout.)

1. Disconnect the negative battery cable.
2. Open the mini fuse box cover (Figure 33).

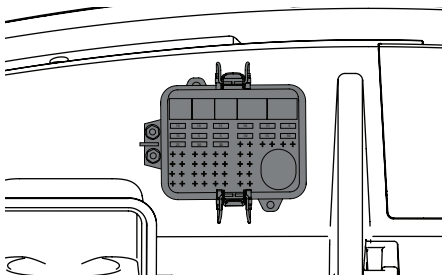

Figure 33

3. Pull out the mini fuse.
4. Insert a new mini fuse into the box.
5. Close the mini fuse box cover.
6. Re-connect the negative battery cable.

Changing the Front & Rear Axle Case Oil

See your authorized service dealer to have the axle case oil changed.

Changing the Brake Fluid

See your authorized service dealer to have the brake fluid changed.

Replacing Radiator Hose

See your authorized service dealer to have the radiator hose changed.

Replacing Fuel Hose

See your authorized service dealer to have the fuel hose changed.

Replacing Brake Master Cylinder

See your authorized service dealer to have the brake master cylinder changed.

Replacing Front Brake Seal

See your authorized service dealer to have the front brake seal changed.

Replacing Rear Brake Cylinder Seal

See your authorized service dealer to have the rear brake seal changed.

Replacing Intake Air Line

See your authorized service dealer to have the air intake line changed.

Replacing Brake Hose

See your authorized service dealer to have the brake hoses changed.

Flushing the Coolant System & Changing Coolant

⚠ CAUTION

Do not remove radiator cap while coolant is hot. When cool slowly rotate to the first stop and allow sufficient time for excess pressure to escape before removing the cap completely.

1. Stop the engine and let it cool down.
2. To drain the coolant, open the radiator drain plug and remove radiator cap. The radiator cap must be removed to completely drain the coolant.
3. After all coolant is drained, close the drain plug.

NOTE: Do not start engine without coolant.

4. Fill with clean water and cooling system cleaner.
5. Follow directions of the cleaner container.
6. After flushing, fill with clean water and anti-freeze until the coolant level is just below the radiator cap.

NOTE: When the antifreeze is mixed with water, the antifreeze mixing ratio must be 50-50. See the Antifreeze section.

7. Install the radiator cap securely. If the cap is loose or improperly fitted, water may leak out and the engine could overheat.

8. Fill with fresh water/antifreeze up to the "FULL" mark on the recovery tank (Figure 22 on page 22).
9. Start and operate the engine for a few minutes.
10. Stop the engine and let cool.
11. Check coolant level of recovery tank and coolant if necessary.
12. Burp (remove air from) the coolant system as instructed in the Burping (Removing Air From) the Coolant System section.

Antifreeze

⚠ WARNING

When using antifreeze, put on some protection such as rubber gloves. (Antifreeze contains poison.) If you should drink antifreeze, throw up at once and seek medical attention. If antifreeze comes in contact with the skin or clothing, wash it off immediately. Do not mix different types of antifreeze. The mixture can produce a chemical reaction between substances. Antifreeze is extremely flammable and explosive under certain conditions. Keep fire away from antifreeze. Keep children away from antifreeze. When draining fluids from the engine, place some container underneath the engine body. Do not pour waste onto the grounds, down a drain or into any water source. Also, observe the relevant environmental protection regulations when disposing of antifreeze.

If it freezes, coolant can damage the cylinders and radiator. If the ambient temperature falls below 0° C (32° F) or before a long-term storage, let out coolant completely, or mix fresh water with long-life coolant and fill the radiator and recovery tank with the mixture.

1. Long-life coolant comes in several types. Use an ethylene glycol (EG) type for this engine.
2. Before employing long-life coolant-mixed cooling water, fill the radiator with fresh water and empty it again.
3. Repeat this procedure two or three times to clean up the inside.
4. Mix the long-life coolant.
5. The procedure for the mixing of water and antifreeze differs according to the make of the antifreeze and the ambient temperature. Refer to SEA J1034 standard, more specifically also to SAE J814c.
6. Add the long-life coolant.
7. If there is a mixture leak, add long-life coolant from the same manufacturer and type in the same mixture percentage.

NOTE: Never mix long-life coolant from different manufacturers. (Different brands may have different additive components, and the engine may fail to perform as specified.)

8. When the long-life coolant is mixed, do not employ any radiator cleaning agent. The long-life coolant contains anticorrosive agent. If mixed with the cleaning agent, sludge may build up, adversely affecting the engine parts.

- The utility vehicle's genuine long-life coolant has a service life of 2 years. Be sure to change the coolant every 2 years.
- Burp (remove air from) the coolant system as instructed in the Burping (Removing Air From) the Coolant System section.

Burping (Removing Air From) the Coolant System

To "burp" the coolant system, proceed as follows:

NOTE: When re-filling the coolant system, this procedure should be performed every time to avoid an overheating risk.

- Chock the rear wheel, engage the parking brake place the shift lever in NEUTRAL or PARK and jack up the front of the utility vehicle approximately 6".
- Remove the bleeder screw (a) on the radiator, fill the radiator and when fluid begins to come out of the bleeder screw hole, replace the bleeder screw (a). The bleeder screw (a) can be accessed via the front right wheel well (Figure 34).

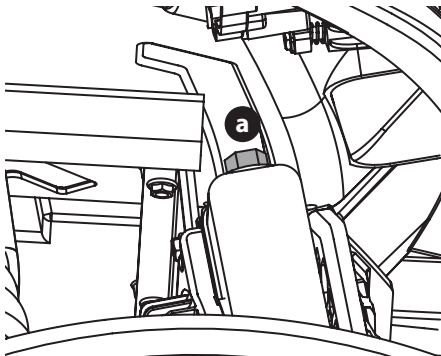

Figure 34

- Start the utility vehicle and let it idle.
- Remove the second bleeder screw (a) where the radiator hose (b) connects to the engine and let the engine run until a steady stream of fluid comes out of the bleeder screw (a) hole indicating there are no more air pockets in the coolant system. Replace the bleeder screw (a) (Figure 35).

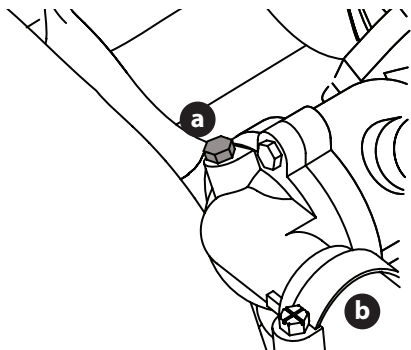

Figure 35

- Top off the radiator and replace the radiator cap. Then lower the front of the utility vehicle off the jack.

Cleaning Primary Air Filter Element

Open the air cleaner cover once a week under ordinary conditions — or daily when used in a dusty place — to get rid of large particles of dust and dirt.

NOTE: Do not run the engine with filter element removed.

- Remove the air filter access panel.
- Remove the air filter cover (a) from the three air filter cover holders (b) (Figure 36).

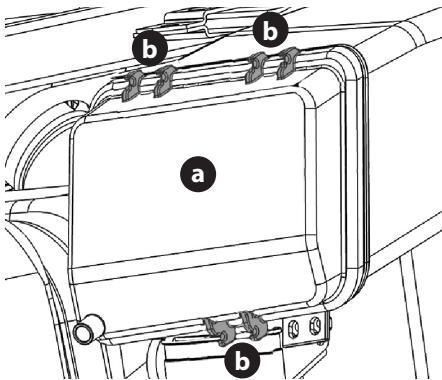

Figure 36

- Remove the air filter element (Figure 37).

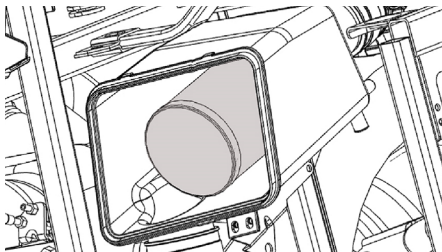

Figure 37

- Remove the inner filter (a) from the paper element (b) (Figure 38).

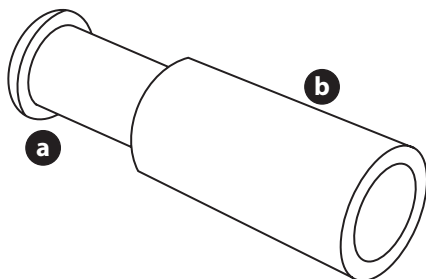

Figure 38

5. Clean the paper element with a soft brush or low pressure air. Be careful not to damage the paper pleats during cleaning.
6. Inspect the inner filter for deposits or damage.
7. If either filter are excessively dirty or damaged, replace filters as a set.
8. Re-install the primary air filter element.
9. Install the air filter case cover and be sure the crankcase breather hose is connected.

NOTE: Be sure to refit the air filter cover with the arrow (on the rear of air filter cover) upright. If the air filter cover is improperly fitted the evacuator valve will not function and dust will adhere to the air filter element.

Cleaning the Air Intake

AIR INTAKE SCREEN

1. Remove the hood and locate the air intake.
2. Remove the rubber seal (b) around the front of the air intake (a) and remove the air intake screen (c) (Figure 39).

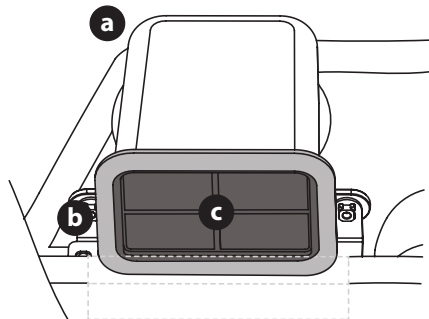

Figure 39

3. Rinse the air intake screen (c) with water and replace the air intake screen (c) and rubber seal (b) (Figure 39).

DRAIN THE AIR INTAKE

1. Remove the nine Allen-head bolts (a) and washers (a) securing the middle skid plate to the bottom of the utility vehicle (Figure 40).

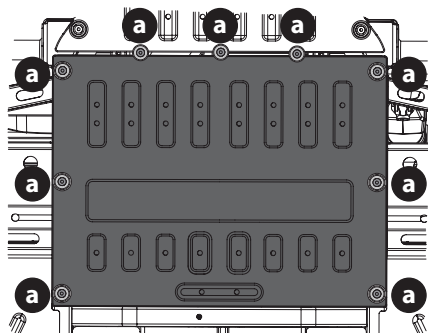

Figure 40

2. Remove the drain and allow the water to run out (a). Then replace the drain and the middle skid plate (Figure 41).

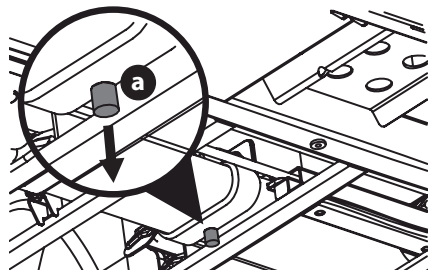

Figure 41

Check Fuel Line & Fuel Filter

⚠ WARNING

Be sure to stop the engine and remove the key. Check the fuel lines periodically. The fuel lines are subject to wear and old fuel may leak onto a running engine which may cause a fire.

The fuel line connections should be checked annually or every 100 service hours whichever comes first. The fuel line is made of rubber and wears regardless of service period.

IMPORTANT! When the fuel line is disconnected for maintenance or repair, close both ends of the fuel line with a piece of clean cloth or paper to prevent dust and dirt from entering. Particular care must be taken not to allow dust and dirt into the fuel pump entrance. Even a small amount of dust or dirt can cause premature wear and the malfunction of the fuel pump and injector components.

1. Park the vehicle on a flat surface and remove the engine access panel. There is a primary fuel filter on the gas tank and an in-line fuel filter between the gas tank and the engine.
2. If the fuel line and clamps are damaged or deteriorated, replace them.
3. There are two main lines (a) coming into the primary fuel filter (b) and one vent line (c) leading to the carbon canister (Figure 42).

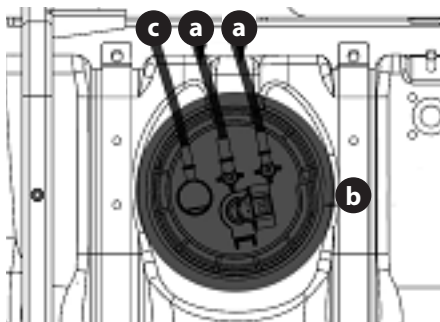

Figure 42

4. Check the fuel filter, if it is clogged by debris or contaminated with water, replace it.
5. To remove the in-line fuel filter clamps (b), slide the clamps (b) away from the in-line fuel filter (a). Twist and pull the fuel lines off of the in-line fuel filter (a) (Figure 43).

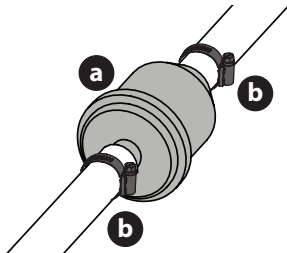

Figure 43

6. Check the in-line filter (a) for debris and/or water contamination. Replace as necessary.

Battery

NOTE: If you store a battery that is not completely charged, the battery may need to be replaced.

WARNING

Never remove the battery while the engine is running. Keep electrolyte away from eyes, hands, and clothes. If you are splattered with it, wash it away completely with water immediately and get medical attention. Wear eye protection and rubber gloves when working around the battery.

NOTE: The factory installed battery is the non-refillable type. If the battery is weak, charge or replace it.

CHARGING THE BATTERY

WARNING

When the battery is being active, hydrogen and oxygen gases in the battery are extremely explosive. Keep open sparks and flames away from the battery at all times, especially when charging the battery. When disconnecting the cable from the battery start with the negative terminal; when connecting the cable to the battery start with the positive terminal. Always check battery charge by using a voltmeter.

1. To slow charge the battery connect the battery positive terminal to the charger positive terminal and the negative to the negative. Then recharge the battery normally.

2. A boost charge is only for emergencies, it will partially charge the battery as quickly as possible.
3. When exchanging an old battery for a new one, use a battery of equal specification. The battery type is a 12 volt battery with a minimum of 300 CCA.

STORING THE BATTERY

When storing the vehicle for a long period, remove the battery and store in a dry place out of direct sunlight. The battery will self-discharge while it is stored. Recharge it once every three months in hot seasons and once every six months in cold seasons.

Adjusting Toe-In

1. Park utility vehicle on a flat surface.
2. Turn the steering wheel so that the front wheels are in the straight position.
3. Lock the parking brake and stop the engine.
4. Measure the distance between the center of the front tires at hub height on the front (a) and rear (b) of the tires (Figure 44).

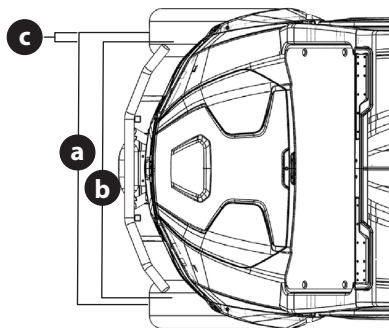

Figure 44

5. The front distance should be shorter than rear distance by 0-.47" (0-12 mm) (c). If not, adjust tie rod length.
6. Loosen the lock nut and turn the inner tie rod to adjust the rod length until the proper toe-in measurement is obtained. Retighten the lock nut.

NOTE: Keep the length of the left and right tie-rods equal.

Cleaning the Spark Arrestor & Muffler

⚠ WARNING

Before touching any part of the exhaust system, be sure that it has had sufficient time to cool. Always wear safety goggles and face mask. The particulate matter contained in the muffler contains chemicals that are harmful to people, animals, and marine life. If you are unable to do this work, have it done by your dealer.

SPARK ARRESTOR

The spark arrestor (a) should be removed, inspected and cleaned every 100 hours of use. The spark arrestor (a) is located inside of muffler (b) body and fastened with bolts (Figure 45).

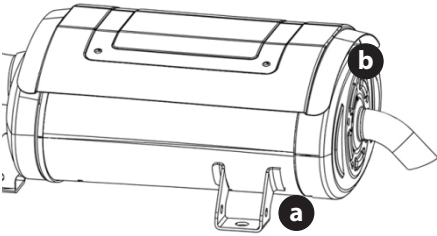

Figure 45

1. Remove the back cover, loosen the bolts and remove the spark arrestor (a).
2. Shake loosened particles out of the screen assembly and lightly clean the screen with wire brush. Soak in solvent and clean with wire brush, if necessary.
3. If there is any damage, the assembly must be replaced.
4. Return the spark arrestor (a) to the muffler (b) and reinstall the bolts.

MUFFLER

1. Visually check the muffler for cracks or holes in the body, weldment or pipes at regular intervals.
2. USDA Forestry Division approval requires clearance between spark arrestor sleeve and muffler body to be no larger than 0.023" (0.584 mm).
3. Replace the entire muffler if it is damaged.
4. Do not operate the vehicle with a damaged muffler.

STORAGE

⚠ WARNING

Do not clean the vehicle when the engine is running. To avoid the danger of exhaust fume poisoning, do not operate the engine in a closed building without proper ventilation. When storing, remove the key from the key switch to avoid unauthorized persons from operating the vehicle and getting injured.

If you intend to store your vehicle for an extended period of time, follow the procedures outlined below.

These procedures will ensure that the vehicle is ready to operate with minimum preparation when it is removed from storage.

1. Check the bolts and nuts for looseness and tighten if necessary.
2. Apply grease to vehicle areas where bare metal will rust and also to pivot areas.
3. Unload from the cargo bed.
4. Inflate tires to 20 psi each.
5. Change the engine oil and run the engine to circulate oil throughout the engine block and internal moving parts for about 5 minutes.
6. With all implements lowered to the ground, coat any exposed rods with grease (if equipped).
7. Remove the battery from the vehicle. Store the battery following the battery storage procedures.
8. Keep the vehicle in a dry place where the vehicle is sheltered from the elements. Cover the vehicle.
9. Keep the vehicle indoors in a dry area that is protected from sunlight and excessive heat. If the vehicle must be stored outdoors. Cover it with a waterproof tarpaulin.
10. Put boards under the tires to keep dampness away from tires.
11. Keep the tires out of direct sunlight and extreme heat.

IMPORTANT! When washing the vehicle, be sure to stop the engine. Allow sufficient time for the engine to cool before washing. Do not wash with a high-pressure pressure washer. Cover the vehicle after the muffler and the engine have cooled down.

Removing the Vehicle from Storage

1. Check the tire air pressure and adjust to recommended pressures indicated on vehicle.
2. Install battery. Before installing the battery, make sure it is fully charged.
3. Check all fluid levels (engine oil, axle case oil, engine coolant and any attached implements).
4. Start the engine. Check to see if the engine cooling fan works. Observe all gauges.
5. If all gauges are functioning properly and reading normal and the cooling fan is working, move the vehicle outside.
6. Once outside, park the vehicle and let the engine idle for at least 5 minutes. Shut the engine off. Work around vehicle and make a visual inspection looking for evidence of oil or water leaks.
7. With the engine fully warmed up, release the parking brake and test the brakes for proper adjustment as you move forward. Adjust the parking brake as necessary.

TROUBLESHOOTING

WARNING

Before performing any type of maintenance/service, disengage all controls and stop the engine. Wait until all moving parts have come to a complete stop. Disconnect spark plug wire and ground it against the engine to prevent unintended starting. Always wear safety glasses during operation or while performing any adjustments or repairs.

This section addresses minor service issues. To locate the nearest authorized service center consult the separate supplement sheet for contact information.

Problem	Cause	Remedy
Engine will not start	<ol style="list-style-type: none"> 1. Battery has low voltage 2. Loose or corroded battery connections 3. Fuse is blown 4. Spark plug wire is loose or disconnected 5. Faulty spark plug or coil 6. No fuel or improper fuel 7. Plugged fuel filter 8. Defective starter solenoid 9. Open-circuit in wiring 	<ol style="list-style-type: none"> 1. Check battery voltage 2. While wearing safety glasses, remove and clean the battery connections using a wire brush or battery terminal cleaner. Reinstall the connections, and ensure they are tight by attempting to "shake/move" them side to side. The connections should not move or rotate. Thoroughly wash hands after cleaning or reinstallation. 3. Visually and mechanically inspect all fuses. 4. Refer to Service manual. Remove the spark plug wire and spark plug. Clean the spark plug as needed and check the Gap setting. Reinstall the spark plug and spark plug wire. The wire should "click or snap" onto the spark plug. 5. Refer to item 4. 6. Refer to Service manual. Ensure the unit contains at least 1/4 tank of clean fuel. 7. Contact your local authorized dealer for service. 8. Contact your local authorized dealer for service. 9. Contact your local authorized dealer for service.
Engine is difficult to start	<ol style="list-style-type: none"> 1. Plugged fuel filter 2. Engine oil viscosity too heavy 3. Spark plug is fouled 4. Faulty spark plug or wire 5. Loose or corroded electrical connections 6. Stale or improper fuel 7. Engine compression failure 	<ol style="list-style-type: none"> 1. Contact your local authorized dealer for service. 2. Refer to label located on top of the air filter, Owner's or Service manual or contact your local authorized dealer for service. 3. Remove and clean or replace spark plug. Ensure coil wire is fully seated during installation. 4. Contact your local authorized dealer for service. 5. Contact your local authorized dealer for service. 6. Refer to Service manual. Ensure the unit contains at least 1/4 tank of clean fuel. 7. Contact your local authorized dealer for service.
Engine misfires under load	<ol style="list-style-type: none"> 1. Faulty spark plug 2. Stale or dirty fuel 3. Plugged fuel filter 4. Faulty coil or wire 5. Damaged ECU 	<ol style="list-style-type: none"> 1. Remove and clean or replace spark plug. Ensure coil wire is fully seated during installation. 2. Refer to Service manual. Ensure the unit contains at least 1/4 tank of clean fuel. 3. Contact your local authorized dealer for service. 4. Contact your local authorized dealer for service. 5. Contact your local authorized dealer for service.

PRODUCT CARE

Problem	Cause	Remedy
Engine does not restart when warm	<ol style="list-style-type: none"> 1. Poor quality fuel 2. Fuel tank vent plugged 3. Dirt in fuel filter 4. Damaged electrical harness 	<ol style="list-style-type: none"> 1. Refer to Service manual. Ensure the unit contains at least 1/4 tank of clean fuel. 2. Contact your local authorized dealer for service. 3. Contact your local authorized dealer for service. 4. Contact your local authorized dealer for service.
Entire electrical system does not work	<ol style="list-style-type: none"> 1. Blown fuse 2. Loose or corroded connections 3. Dead or faulty battery 	<ol style="list-style-type: none"> 1. Visually and mechanically inspect all fuses. Replace any blown fuses with the same type and ratings as the blown fuse. Should the fuse blow again, contact your local authorized dealer for service. 2. Battery terminals only. While wearing safety glasses, remove and clean the battery connections using a wire brush or battery terminal cleaner. Reinstall the connections, and ensure they are tight by attempting to "shake/move" them side to side. The connections should not move or rotate. Thoroughly wash hands after cleaning or reinstallation. 3. Check battery voltage.
Dead battery	<ol style="list-style-type: none"> 1. Shorted starter solenoid 2. Key switch not turned to STOP position 3. Faulty battery 	<ol style="list-style-type: none"> 1. Contact your local authorized dealer for service. 2. Turn the ignition key to the "OFF" position and charge the battery. 3. Contact your local authorized dealer for load testing/servicing.
Battery will not take a charge	<ol style="list-style-type: none"> 1. Dead battery 2. Loose or corroded connections 	<ol style="list-style-type: none"> 1. Contact your local authorized dealer for load testing/servicing. 2. For battery terminals only. While wearing safety glasses, remove and clean the battery connections using a wire brush or battery terminal cleaner. Reinstall the connections, and ensure they are tight by attempting to "shake/move" them side to side. The connections should not move or rotate. Thoroughly wash hands after cleaning or reinstallation.
Difficult to shift	<ol style="list-style-type: none"> 1. Linkage needs adjusted/cleaned. 2. Brake pedal needs more force. 3. Gears bound up/unit parked/stopped on an incline/decline. 	<ol style="list-style-type: none"> 1. Contact your local authorized dealer for service. 2. Apply additional pressure to the brake pedal to fully engage the parking brake safety switch. Adjustments shall only be completed by your local authorized dealer. 3. Depress the brake pedal and engage the parking brake. Turn the unit off and then back on.
Indicator lights do not come on when key switch is in START position	<ol style="list-style-type: none"> 1. Battery needs charged. 2. Faulty display or wiring. 	<ol style="list-style-type: none"> 1. Check the battery voltage and see if the unit will start. If the unit starts, contact your local authorized dealer for service. 2. Contact your local authorized dealer for service.
Engine runs unevenly	<ol style="list-style-type: none"> 1. Spark plug is fouled. 2. Air cleaner element plugged. 3. Improper or stale fuel. 4. Loose electrical connections. 5. Fuel line, filter or injector clogged. 	<ol style="list-style-type: none"> 1. Check all components in the order listed. 2. Clean or replace the spark plug. Ensure the gap is set properly. 3. Clean or replace the filter. Ensure the enclosure is properly closed after cleaning/replacing. 4. Ensure the unit is at least 1/4 full of proper, fresh, clean fuel. 5. With the unit parked on a level surface, turned off, and cool, ensure all visible electrical connections are secure. <p>Additional checks shall be performed by your local authorized dealer.</p>

PRODUCT CARE

Problem	Cause	Remedy
Engine overheats	<ol style="list-style-type: none"> 1. Cooling fan not turning 2. Coolant level is low 3. Air cleaner element missing or plugged 4. Engine oil low 5. Radiator fins are clogged. 6. Coolant System needs purged. 	<ol style="list-style-type: none"> 1. Listen or look for the radiator fan to turn on. The unit must be running, or the key switch in the run position. If the dash indicates the engine has over heated, immediately turn the unit off and then turn the key switch to the run position. If the fan does not turn on, check the fuses. If the fuses have not failed allow the unit to cool off before attempting to operate again. The unit must be stopped and allowed to cool to help avoid additional damage. Contact your local authorized dealer for service immediately after any overheating condition. 2. NEVER ADD COOLANT OR REMOVE THE RADIATOR CAP ON A WARM OR HOT ENGINE. DOING SO CAN CAUSE SERIOUS INJURY. Check the fluid level in the overflow reservoir and add as needed. 3. Inspect and clean/replace the air filter as needed. Ensure the housing is properly closed after inspection/replacement. 4. Ensure the engine oil level is correct. The engine oil level should be checked on a flat surface after the engine has had time to cool. 5. Use a garden hose with a sprayer attached, spray the back side and then the front side of the radiator to clean the fins. The water should spray through the fins in a mist. 6. If the unit is still showing signs of overheating, there maybe air entrapped with the cooling system. Contact your local authorized dealer for servicing.
Engine loses power	<ol style="list-style-type: none"> 1. Engine overheating. 2. Too much oil in engine. 3. Faulty spark plug. 4. Air cleaner element plugged. 5. Fuel issues. 	<ol style="list-style-type: none"> 1. See Engine Overheating Section. 2. Contact your local authorized dealer for servicing. 3. Inspect, clean/replace the spark plug. Ensure the spark plug gap is properly set. 4. Inspect, clean/replace the air filter. Ensure the housing is properly closed after inspection/replacement. 5. Contact your local authorized dealer for servicing.
Starter does not work	<ol style="list-style-type: none"> 1. Battery 2. Loose or corroded connections 3. Starter 	<ol style="list-style-type: none"> 1. Check the battery voltage using a voltage meter set on the DC setting. This check should be completed with the unit off and while attempting to start the unit. While attempting to start the unit, the voltage should not drop below 9.8 VDC. If the voltage does drop below this, contact your local authorized dealer for service. 2. Disconnect the negative battery terminal before attempting to service. Inspect and clean as needed all electrical connections to the starter. If you are unsure on how to perform this task, contact your local authorized dealer for servicing. 3. If the starter is making a "clicking" sound, check the battery voltage. If the battery voltage is ok, contact your local authorized dealer for servicing.
Starter cranks slowly	<ol style="list-style-type: none"> 1. Weak or Low Battery. 2. Worn Starter. 	<ol style="list-style-type: none"> 1. Check the battery voltage. If the voltage is low, clean the battery terminals and connections prior to charging. If the battery will not maintain a charge, contact your local authorized dealer for servicing. 2. See "Starter does not work" section.

PRODUCT CARE

Problem	Cause	Remedy
Battery light comes on when engine is running	<ol style="list-style-type: none">1. Weak or Low Battery.2. Loose electrical connections within the charging system.3. Excessive current draw from Accessories.	<ol style="list-style-type: none">1. Check Battery Voltage.2. Ensure all electrical connections are secure.3. Contact your local authorized dealer for a current draw inspection.
Vehicle will not move	<ol style="list-style-type: none">1. Shift Lever not in gear.2. Parking Brake still set3. Failed Drive Belt or Slipping clutch.	<ol style="list-style-type: none">1. Check the dash display to ensure the desired direction of travel is indicated.2. Check the dash display to see if the Parking Brake indicator is illuminated. If yes, fully release the parking brake.3. Ensure the dash display indicates the desired direction of travel. If the engine rpm's increase but the unit will not move, record the rpm value and contact your local authorized dealer for service.

SPECIFICATIONS

Make			Specifications
Engine	Type		1 cylinder, 4-cycle, gasoline, SOHC, liquid cooled
	Displacement		cc 546CC for 550UTV 735CC for 750UTV
	Horsepower		Kw (HP) 20.2 (27.1) for 550UTV 28.8 (38.6) for 750UTV
	Rated Revolution		rpm 5500 rpm for 550UTV 6000 for 750UTV
	Low Idling Revolution		rpm 1500 ±150
Fuel Capacity			L (U.S. gal.) 28 (7.4)
Oil Capacity			L (U.S. quart) 2.1 (2.22)
Transmission			CVT
Wheels, Drive System			4, Rear 2WD or 4WD
Differential Lock			Electronic Control, Switch
Gear Selection			H-L range FORWARD, NEUTRAL, REVERSE, PARK
Brakes	Front/Rear		Wet disc brake
	Parking Brake		Axis brake, hand braking
Steering			Manual (Electronic Power Steering Optional)
Dimensions	Length		mm (in.) 2960 (116.5)
	Width		mm (in.) 1540 (60.63)
	Height		mm (in.) 1950 (76.77)
	Front Tread Centers		mm (in.) 1310 (51.57)
	Rear Tread Centers		mm (in.) 1290 (50.79)
	Wheel Base		mm (in.) 1950 (76.77)
	Ground Clearance	Front axle	mm (in.) 295 (11.6)
		Rear Axle	330 (13.0)
Turning Diameter		m (ft.) 8.6 (28.22)	

SPECIFICATIONS

Make		Specifications	
Suspension	Front	Independent, Dual A-arm type	
	Rear	Independent, Dual A-arm type	
Max rolling weight (Towing capacity)		kg (lbs.)	544 (1200)
Payload capacity (Cargo Bed)		kg (lbs.)	227 (500)
Vehicle Curb Weight		kg (lbs.)	748 (1646)
Cargo Bed	Width	mm (in.)	1170 (46.06)
	Length	mm (in.)	900 (35.43)
	Depth	mm (in.)	280 (11)
	Volume	m ³ (cu. ft.)	0.29 (10.24)
	Bed height (Unloaded)	mm (in.)	810 (31.89)
	Cargo bed capacity (1 row/2 row)	kg (lbs.)	227 (500)
Sound level, operator ear		db (A)	86.5
Tire	Front	26 x 9.00-14NHS	
	Rear	26 X 11.00-14NHS	
Body Color		Black, yellow, camo	

NOTE:

- The company reserves the right to change the specifications without notice.

SPECIFICATIONS

Fuse Box

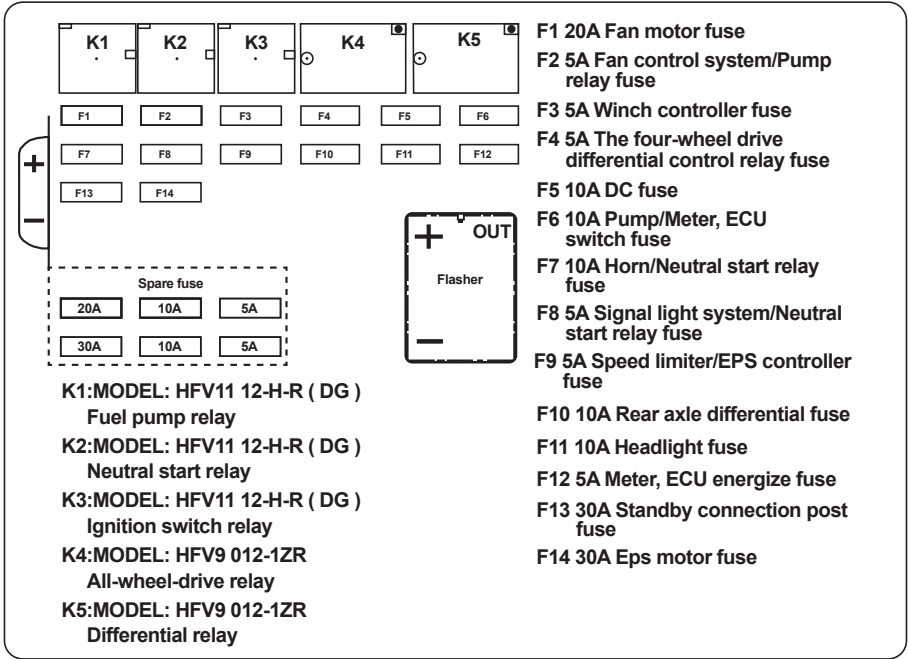

Figure 46

Traveling Speeds

550UTV

Range gear shift lever	km/h (mph)
Low	54.9 (34.1)
High	64.9 (40.3)
Reverse	20.9 (13.0)

750UTV

Range gear shift lever	km/h (mph)
Low	57 (35.4)
High	80 (49.7)
Reverse	40 (24.8)

Vehicle Limitations

The Vehicle has been thoroughly tested for proper performance with implements sold or approved by manufacturer. Use with implements which are not sold or approved and which exceed the maximum specifications listed below, or which are otherwise unfit for use on this vehicle, may result in vehicle malfunction or failures with a possibility of vehicle damage, property damage and injury to the operator or others. Any malfunctions or failures of the vehicle resulting from use with improper implements are not covered by the warranty.

Max cargo loading weight	
Cargo Bed Capacity = 227 kg (500 lb)	Max. rolling weight trailer
Vehicle Total Load Capacity = 453.5 kg (1000 lb)	544 kg (1200 lbs)
* (Operator + one passenger + opt + acc) weight + trailer weight	Max. tongue weight
	50 kg (110 lbs)

1. Above mentioned specifications are based on level ground condition.

Hisun Motors Corp., U.S.A. Emission Control System Warranty Statement

YOUR WARRANTY RIGHTS AND OBLIGATIONS

The U.S. Environmental Protection Agency and **Hisun Motors Corp., U.S.A.** (hereinafter "**HISUN**") are pleased to explain the emission control system warranty on your Off-Road vehicle. New off-road motor vehicles must be designed, built and equipped to meet U.S. EPA Federal and California anti-smog standards. HISUN must warrant the emission control system on your vehicle for 5,000 km, or at least 30 months, whichever comes first, provided that there has been no abuse, neglect or improper maintenance of your vehicle. This off-road vehicle was designed to meet the emission standards for 10,000 km, or five years, whichever comes first.

Your emission control system warranty covers components whose failure would increase an engine's emissions of any regulated pollutant

Where a warrantable condition exists, HISUN will repair your vehicle at no cost to you, including diagnosis, parts and labor.

If an emission-related part on your vehicle is defective, the part will be repaired or replaced by HISUN. This is your EMISSION CONTROL SYSTEM WARRANTY.

NOTICE! Use of this vehicle in any type of competitive event completely and absolutely voids this and all other warranties offered by HISUN.

OWNER'S WARRANTY RESPONSIBILITIES

As the vehicle owner, you are responsible for the performance of the required maintenance listed in your owner's manual. HISUN recommends that you retain all receipts covering maintenance on your vehicle, but HISUN cannot deny warranty solely for the lack of receipts or for your failure to ensure the performance of all scheduled maintenance.

You are responsible for presenting your vehicle to the HISUN dealer as soon as a problem exists. The warranty repairs should be completed in a reasonable amount of time, not to exceed 30 days.

As the vehicle owner, you should be aware that HISUN may deny your warranty coverage if your vehicle or a part has failed due to abuse, neglect, improper maintenance or unapproved modifications.

If you use your vehicle in any type of competitive event, this warranty is immediately and completely void.

If you have any questions regarding your warranty rights and responsibilities, you should contact Hisun Motors Corp., U.S.A., 310 E, University Drive, McKinney, TX 75069 (Phone: 972-446-0760 or Toll Free: 877-838-6188), or the U.S. Environmental Protection Agency at 2000 Traverwood Drive, Ann Arbor, MI 48105.

Hisun Motors Corp., U.S.A. Limited Warranty on Emission Control System

YOUR WARRANTY RIGHTS AND OBLIGATIONS

Hisun Motors Corp., U.S.A. warrants that each new off-road vehicle:

A. is designed, built and equipped so as to conform at the time of initial retail purchase with all applicable regulations of the United States Environmental Protection Agency, and

B. is free from defects in material and workmanship which cause such vehicle to fail to conform to applicable regulations of the United States Environmental Protection Agency for the periods specified above.

I. Coverage. Warranty defects shall be remedied during customary business hours at any authorized HISUN dealer located within the United States of America in compliance with the Clean Air Act and applicable regulations of the United States Environmental Protection Agency. Any part or parts replaced under this warranty shall become the property of HISUN.

II. Limitations This Emission Control System Warranty shall not cover any of the following:

A. Repair or replacement as a result of

- (1) accident,
- (2) misuse,
- (3) repairs improperly performed or replacements improperly installed, unless performed by a HISUN authorized dealer,
- (4) use of improper replacement parts or accessories not conforming to specifications set forth by HISUN, which adversely affect performance and/or
- (5) Use in competitive racing or related events.

B. Inspections, replacement of parts and other services and adjustments required for required maintenance.

C. Any vehicle equipped with an odometer or hour meter on which the odometer mileage or hour meter reading has been changed so that actual mileage cannot be readily determined.

III. Limited Liability

A. The liability of HISUN under this Emission Control System Warranty is limited solely to the remedying of defects in material or workmanship by an authorized HISUN dealer at its place of business during customary business hours. This warranty does not cover inconvenience or loss of use of the vehicle or transportation of the vehicle to or from the HISUN dealer. HISUN shall not be liable for any other expenses, loss or damage, whether direct, incidental, consequential or exemplary arising in connection with the sale or use of or inability to use the vehicle for any purpose. Some states do not allow the exclusion or limitation of any incidental or consequential damages, so the above limitations may not apply to you.

Hisun Motors Corp., U.S.A. Limited Warranty on Emission Control System

B. No express emission control system warranty is given by HISUN except as specifically set forth herein. Any emission control system warranty implied by law, including any warranty of merchantability or fitness for a particular purpose, is limited to the express emission control system warranty terms stated in this warranty. The foregoing statements of warranty are exclusive and in lieu of all other remedies. Some states do not allow limitations on how long an implied warranty lasts, so the above limitations may not apply to you.

C. No dealer is authorized to modify this Limited Emission Control System Warranty issued by HISUN.

IV. LEGAL RIGHTS. This warranty gives you specific legal rights, and you may also have other rights which vary from state to state.

V. This warranty is in addition to the limited vehicle warranty.

VI. ADDITIONAL INFORMATION. Any replacement part that is equivalent in performance and durability may be used in the performance of any maintenance or repairs by the owner. However, HISUN is not liable for these parts. The owner is responsible for the performance of all required maintenance. Such maintenance may be performed at a service establishment or by any individual. The warranty period begins when the vehicle is placed into service.

If you have any questions regarding your warranty rights and responsibilities, you should contact Hisun Motors Corp., U.S.A., or the U.S. Environmental Protection Agency at 2000 Traverwood Drive, Ann Arbor, MI 48105.

Hisun Motors Corp., U.S.A.

310 E. University Drive McKinney, TX 75069

Phone: 972-446-0760

Fax: 972-446-0765

Toll-Free: 877-838-6188