

STORAGE

STORAGE

WARNING: Always be extra careful when handling the blades. Blades are very sharp.

Make sure the unit is clean and dry prior to storing it. Follow the Cleaning instructions on pages 5+6.

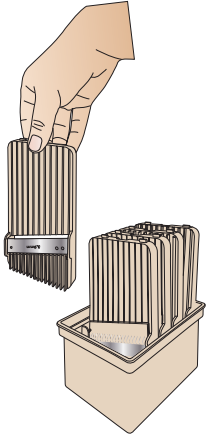

- 1 Store the blades with metal part facing down inside the storage box.

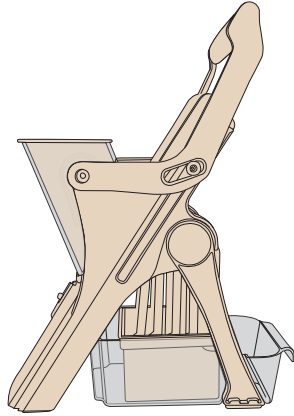

- 2
 - Place the Pusher inside the Feeder.
 - Store the storage box with blades inside the container.
 - Slide the food container with blades under the unit.
 - You may also fold the main unit down and store it flat.

NUTRI SLICER™ MANDOLINE ITEM NO. 2355Q

Distributed by Emson® New York, NY 10001, USA

©Copyright Emson® 2024 All Rights Reserved. Made in China.

NutriSlicer™

UPRIGHT MANDOLINE

Slice Fruits, Vegetables
& Cheese Easily!



INSTRUCTIONS

READ ALL INSTRUCTIONS THOROUGHLY PRIOR TO USE.

IMPORTANT SAFEGUARDS

Before using this unit, the following basic precautions should always be followed including the following:

1. Read all instructions.
2. Close supervision is necessary when the unit is operated near children. Do not allow children to use this unit.
3. The use of accessories not recommended by the manufacturer may cause injuries to persons.
4. Do not use the unit for other than its intended use.
5. To avoid injury, never put hands or sharp objects on the blade or touch the blade when operating the unit.
6. Do not use fruits with hard seeds as it may damage the blades.
7. Prior to using the device, always check to ensure that all parts are properly assembled.
8. This appliance is not intended for use by persons (including children) with reduced physical, sensory or mental capabilities, or lack of experience and knowledge, unless they have been given supervision or instruction concerning use of the appliance by a person responsible for their safety. Children should be supervised to ensure that they do not play with the appliance.
9. Avoid contact with sharp blades while in use to prevent injury.

CAUTION! To prevent any type of cutting injury follow the instructions below.

- The blades are extremely sharp. Do not touch the blades with your fingers/hands.
- When pressing down on the Handle, never use your fingers to push food through to the blade under any circumstances. Use the food pusher, if needed.
- Never use your fingers to remove food that may get stuck in the blades, use a fork to pick it out.
- Keep the product out of the reach of children and animals.

UNPACKING - BEFORE FIRST USE

PACKAGE CONTENTS: Main unit with feeder, food pusher, 5 blades, blade storage box and container.

Unpack the unit and all parts and remove all packaging materials. Before using the unit for the first time, rinse all parts in warm soapy water prior to use. Dry all parts thoroughly. Refer to a full cleaning instructions if needed.

WARNING: Blades are extremely sharp, handle with care. Do not place fingers and hands on the surface of the blade. Keep blades inside storage box when not in use.

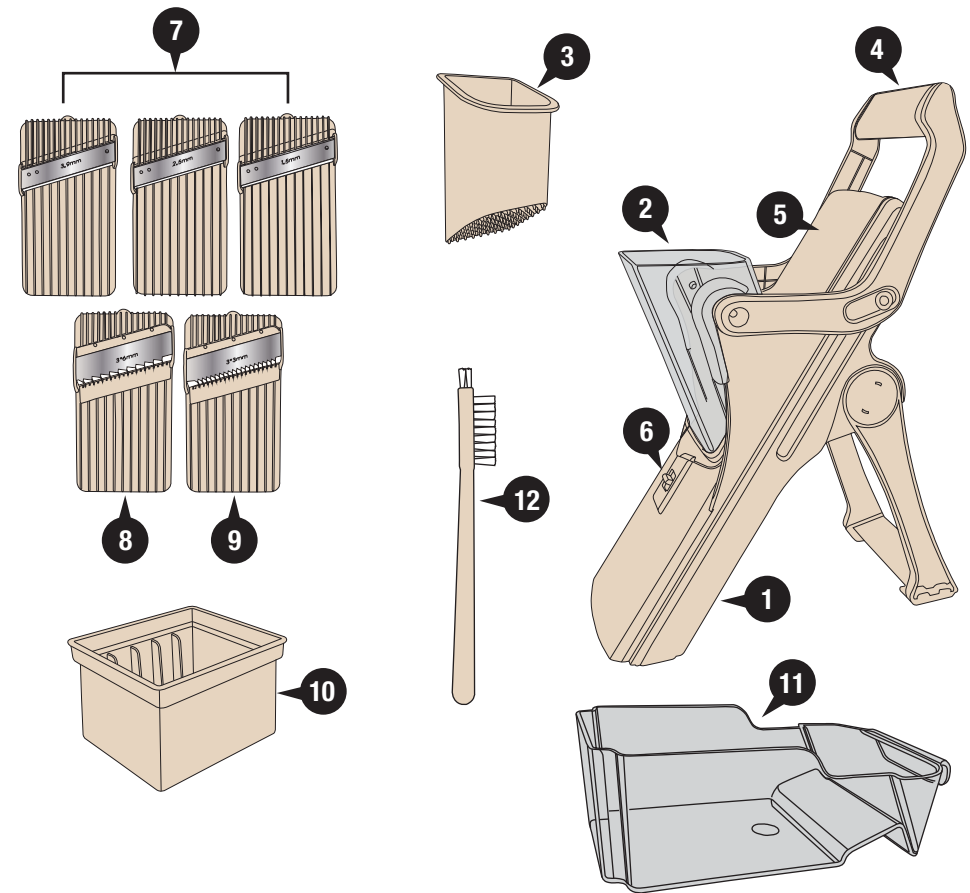

1. Main Unit
2. Food Chute - holds food to be cut
3. Fruit/Vegetable Pusher - helps to push the food down the chute and towards the blade
4. Ergonomic Handle - press down to cut food
5. Cover - protects blade assembly
6. Blade Lock - releases cover to access the blade assembly
7. 3 Slicing Blades (1.5mm, 2.5mm, 3.9mm thickness)
8. French Fry Cutter (3*6mm)
9. Julienne Cutter (3*3mm)
10. Blade storage box
11. Catch Tray - slides under unit to catch food
12. Cleaning Brush - has 2 different size brush heads for precise cleaning.

SET UP - BLADE SELECTION

SET UP

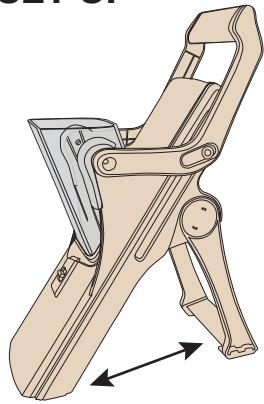

- 1 Unfold the main unit as shown above. Place it on a hard, stable surface.

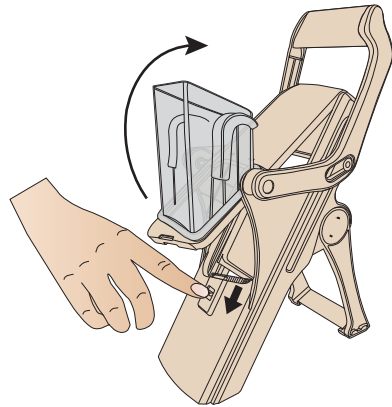

- 2 Press the Blade Lock down to unlock the cover and lift it up.

BLADE SELECTION & INSTALLATION

CAUTION! When handling the sharp blades, avoid direct contact to prevent injury. Do not touch the metal part of the blade with your fingers/hands.

3 SELECT THE BLADE:

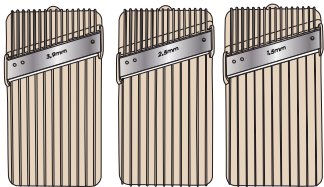

3 SLICING BLADES

(1.5mm/2.5mm/3.9mm)

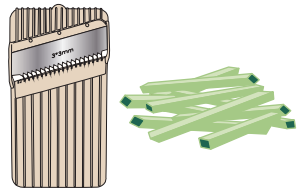

JULIENNE CUTTER

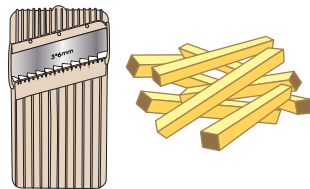

FRENCH FRY CUTTER

BLADE INSTALLATION - USAGE

4 INSTALL THE BLADE:

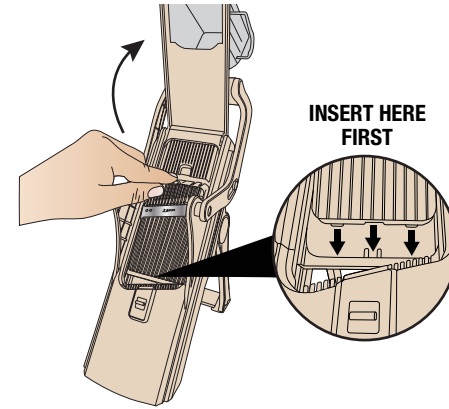

- Lift the Cover up.
- **FIRST**, insert the blade by aligning it with all 3 tabs on the bottom. This ensures proper blade placement.
- Next, bring the top of the one large tab on the top.
- Snap the blade in place.

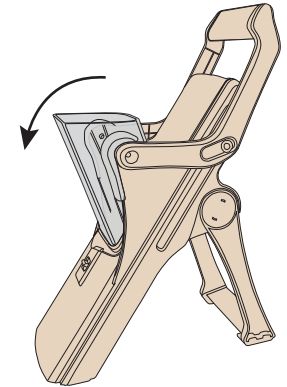

Bring the Cover with Food Chute down, lock it in place.

USAGE

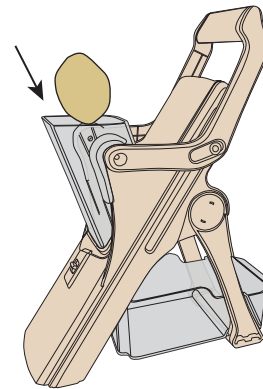

- 1 • Place the appliance on a smooth, flat surface like a table or countertop.
- Slide the Catch Tray under the main unit to catch food that has been cut.
- Place desired food into the Food Chute. If food does not fit, cut it in half.

Important: Do not use fruits with hard seeds as it may damage the blades.

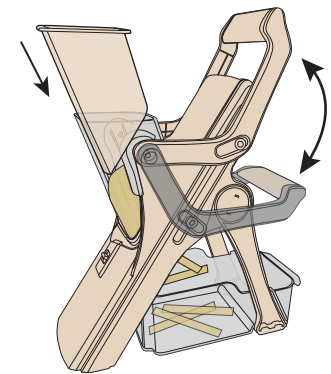

- 2 • Insert the Pusher inside the Feeder. Hold the Pusher down with one hand.
- To chop the food, keep pressing down and releasing the Handle with the other hand.
- The chopped food will go directly under the unit and inside the Catch Tray.
- When done chopping food, remove the Catch Tray from underneath the unit and empty it.

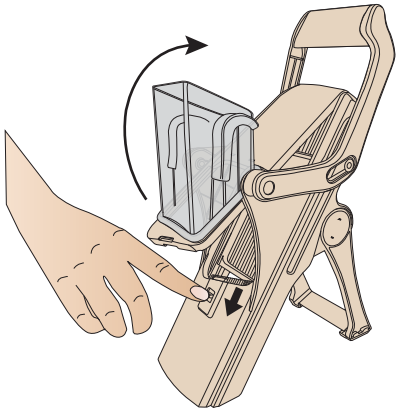

- 3** • If any additional chopping is needed, select another blade.
- To remove the current blade, press the Blade Lock down to unlock the cover and lift it all the way up.

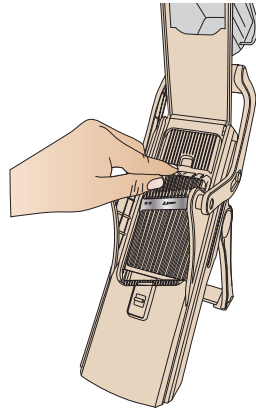

- 4** • Using the tab on the top of the blade, pop the blade out to remove it. Lift the blade out without touching the metal part of the blade.
- Refer to the **Blade Selection** on previous page to select and install a new blade.

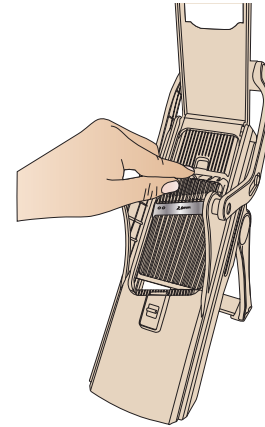

- 3** Using the tab on the top of the blade, pop the blade out to remove it. Lift the blade out without touching the metal part of the blade.

- 4** • First, rinse the unit under running water. Use provided Cleaning Brush to rid of any stuck pieces. Choose from 2 different size heads.
- Wash all parts in a mild soap solution or place in the dishwasher (top rack only).
 - Do not use abrasive cleansers.
 - Dry off all parts.

CLEANING

CAUTION!

- The blades are extremely sharp. Do not touch the blades with your fingers/hands.
- Never use your fingers to remove food that may get stuck in the blades, use a fork to pick it out.

Clean the unit soon after each use. This greatly simplifies the cleaning process.

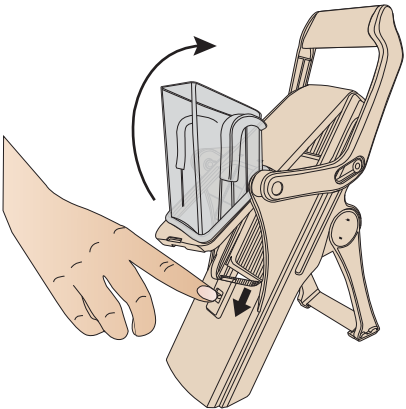

- 1** Press the Blade Lock down to unlock the cover. Remove the empty Catch Tray.

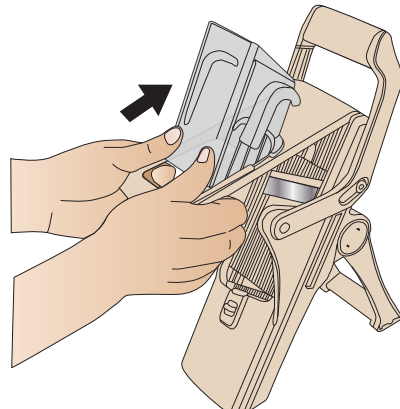

- 2** Grasp the cover with both hands with the thumbs on the Food Chute. Remove the Food Chute by sliding it upward.

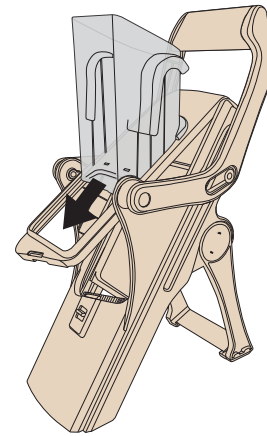

- 5** Install the Food Chute by sliding the Food Chute into the grooves of the Cover. Push it in all the way.