

175 PSI Oil-Free 26 Gallon Tank Super Quiet Air Compressor OPERATOR'S MANUAL

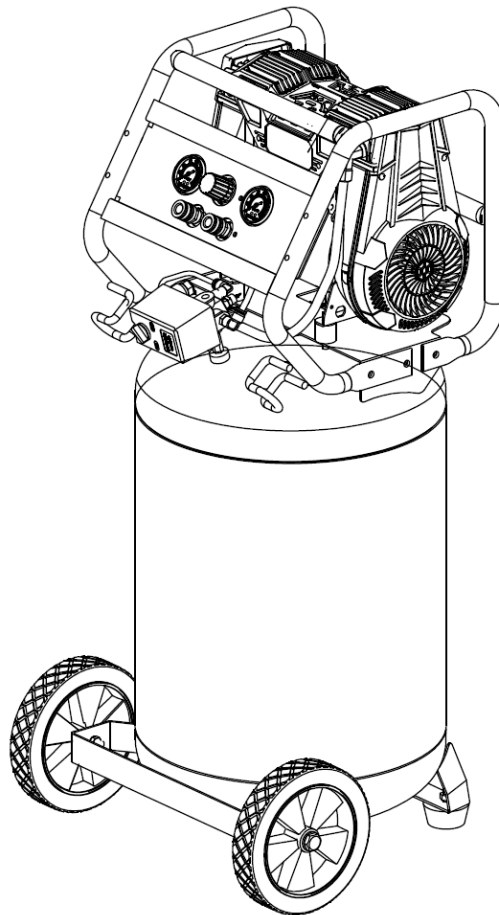

Caution:

- Before using your air compressors, please read this manual carefully to understand the proper use of your unit
- Keep this manual handy



WARNING: This product and dust created by its use may contain chemicals, including lead, known to the State of California to cause cancer, birth defects, or other reproductive harm. Wash hands after handling. For more information, visit www.P65warnings.ca.gov.

	DO NOT RETURN TO STORE!
	HAVE QUESTIONS OR NEED SERVICE?
1-866-591-8921	support@pulsar-products.com

Table of Contents

Table of Contents	1	Maintenance	7
Introduction	1	Troubleshooting Guide	9
Safety Warnings and Notices	1	Specifications	10
Safety Instructions	2	Exploded View	11
Preparation & Installation.....	5	Parts List.....	12
Operation.....	6		

Introduction

Thank you for choosing this Goodyear Air Compressor.

This manual provides instructions on operating and using your air compressor safely and correctly; be sure to read and understand this manual before using your air compressor. If you have **ANY questions**, please phone **1.866.591.8921** or email **support@pulsar-products.com** **BEFORE** using your air compressor.

All details and images in this Operator's Manual are believed to be accurate at publication.

This manual is a permanent part of the air compressor set. If the air compressor is resold, kindly include this manual with the air compressor.

Safety Warnings and Notices

WARNING: Save This Manual for Future Reference

This manual contains important information regarding the safety, operation, maintenance, and storage of this product. Before use, read are fully and understand all cautions, warnings, instructions, and product labels. Failure to do so could result in serious personal injury and/or property damage

Safety Definitions

This manual contains important information regarding the safety, operation, maintenance, and storage of this product. Before use, read are fully and understand all cautions, warnings, instructions, and product labels. Failure to do so could result in serious personal injury and/or property damage.

 This safety alert symbol appears with most safety statements. It means to pay attention and be alert, your safety is involved! Please read and abide by the message that follows the safety alerts symbol.

DANGER

DANGER indicates an imminently hazardous situation which, if not avoided, will result in death or serious injury.

WARNING

WARNING indicates a potentially hazardous situation which, if not avoided, could result in death or serious injury.

CAUTION

CAUTION indicates a potentially hazardous situation which, if not avoided, may result in minor or moderate injury. It may also be used to alert against unsafe practices.

NOTICE

Failure to follow the instruction may result in the damage to your air compressor and other property.

Safety Instructions

Hazard Warnings

WARNING









This product may expose you to chemicals, including lead and DEHP, which are known to the State of California to cause cancer, birth defects, or other reproductive harm. Wash your hands thoroughly after handling. For more information, visit P65Warnings.ca.gov.

Improper operation or maintenance of this product may result in serious injury and/or property damage. Please read and fully understand all warnings and safety instructions provided before using this equipment.

NOTICE

The air compressor must be operated on a dedicated 20-amp circuit. If the circuit cannot support the load or if a circuit breaker trips, relocate the compressor to a different circuit.

Always prioritize using additional air hose over utilizing extension cords. If extension cords are necessary, they must be at least 12-gauge with a maximum length of 25 feet. The circuit fuse type should be a time-delay fuse. Note that low voltage may cause damage to the motor.

	Rick of Moving Parts
	Risk of Burns
	Risk of Falling
	Risk of Flying Objects
	Risk of Breathing
	Risk of Electrical Shock
	Risk of Explosion or Fire
	Risk of Bursting

Rick of Moving Parts

All guards and covers must be properly installed during air compressor operation. Do not use the compressor if any guard is missing or damaged; have it repaired by authorized personnel before use. Ensure the power cord is free of kinks, bends, or damage, and handle it with care during storage.

Risk of Burns

Certain surfaces on your air compressor can become extremely hot during and after operation, posing a risk of serious burns if touched. Allow the equipment to cool completely before performing any maintenance. Components like the compressor pump and outlet tube remain hot and should be handled with caution.

Safety Instructions

WARNING

What could happen:

- Abrasive tools such as sanders and grinders, rotating tools such as drills, and impact tools such as nail gun, staplers, wrenches, hammers, and reciprocating saws can generate sparks that may ignite flammable materials.
- It is normal for the compressor motor and pressure switch to produce sparks while operating. If sparks come into contact with vapors from gasoline or other solvents, they may ignite, causing a fire or explosion.
- Exceeding the maximum pressure rating of tools or accessories could result in an explosion, causing serious injury.

How to prevent it:

- Never operate tools near flammable substances such as gasoline or cleaning solvents.
- Work in a clean, well-ventilated area free of combustible materials.
- Never use oxygen, carbon dioxide, or other bottled gases as a power source for air tools.
- Use compressed air regulated to a maximum pressure that does not exceed the rated pressure of any attachments.
- Always verify before using the tool that the air source has been adjusted to the appropriate air pressure range.
- Never spray flammable liquids in a confined area and avoid spraying where sparks or flames are present.
- Do not smoke while spraying.

Risk Of Falling

The air compressor must always be operated in a stable position. Never use the compressor on a rooftop or any elevated surface where it could fall or tip over. For elevated tasks, use additional air hose instead.

Risk Of Flying Objects

NEVER direct compressed air or aim any nozzle or sprayer at yourself, other people, or animals. Always turn off the air compressor and fully drain the air tank before performing maintenance or disconnecting hoses or fittings. Handle nozzles and sprayers responsibly to avoid accidents.

Risk Of Breathing or Inhalation Hazard

WARNING

What could happen:

- Abrasive tools such as grinders, sanders, and cut-off tools generate dust and abrasive materials that can be harmful to the lungs and respiratory system.
- Some materials, such as adhesives and tar, contain chemicals whose vapors could cause respiratory damage. Be sure to read all instructions to ensure that your respirator mask provides adequate protection.

How to prevent it:

- Always work in a clean, dry, and well-ventilated area.
- Never directly inhale compressed air produced by a compressor, as it is not suitable for breathing purposes.
- Always read labels and follow safety instructions when spraying paints or toxic materials.

Safety Instructions

Risk Of Electric Shock

WARNING

What could happen:

- Using air tools powered by an oil-less air compressor to attach electrical wiring can result in electrocution or death.
- Improper electrical connections with the oil-less air compressor can lead to fires, electrocution, or death.
- If the oil-less compressor is not provided with an insulated gripping surface, contact with a “live” wire can electrify exposed metal tool parts, leading to electrocution or death.
- Fasteners propelled by the oil-less air compressor coming in contact with hidden electrical wiring could cause electrocution or death.

How to prevent it:

- Never attach electrical wiring with energized tools when using the oil-less air compressor.
- Avoid body contact with grounded surfaces (e.g., pipes, radiators, ranges, refrigerators) as grounding increases the risk of electric shock.
- Thoroughly inspect the workpiece for hidden wiring before using the oil-less air compressor.
- Ensure all wiring is installed by a licensed electrician following local and national codes.
- Never use the oil-less air compressor outdoors in rain or on wet surfaces, as it could cause an electric shock.

Risk of Explosion or Fire

CAUTION

Never operate the air compressor near combustible materials, gasoline, or solvent vapors. If spraying flammable materials, position the air compressor at least 20 feet away from the spray area. Always use the air compressor in a well-ventilated outdoor area, never indoors or in confined spaces.

Risk of Bursting

Always drain the air compressor tank daily or after each use. If the tank develops a leak, replace the air compressor immediately. Never use the air compressor after a leak is detected, nor attempt to repair or modify the tank. Additionally, never alter the factory settings that control tank pressure or any other function of the air compressor.

Glossary

- **CFM:** Cubic Feet per Minute – A measure of airflow delivery.
- **SCFM:** Standard Cubic Feet per Minute – A standardized measure of air delivery under specific conditions.
- **PSIG:** Pounds per Square Inch Gauge – A unit of pressure measured relative to atmospheric pressure.
- **ASME:** American Society of Mechanical Engineers – An organization that sets safety and quality standards for mechanical equipment.
- **Code Certification:** Indicates compliance with safety standards set by organizations like UL, CUL, ETL, or CSA. Certified products have been evaluated by OSHA-authorized safety laboratories and meet applicable safety standards.
- **Cut-in Pressure:** The air compressor automatically starts refilling the tank when the pressure falls below the minimum prescribed level.
- **Cut-out Pressure:** The point at which the motor stops running after the tank reaches the maximum air pressure.

Preparation & Installation

Parts

1. **Air Intake Filter:** Provides clean air to the pump and must always be kept free of debris. Inspect daily before each use.
2. **Check Valve:** An internal component that closes when the pump is not in operation to retain air pressure inside the tank.
3. **Tank Safety Valve:** Allows excess tank pressure to escape into the atmosphere. This valve opens only when the tank pressure exceeds the maximum rated pressure.
4. **Pressure Switch:** Controls power to the motor and manages cut-in/cut-out pressure settings. It also provides automatic ON and OFF control for the compressor motor.
5. **Tank Pressure Gauge:** Displays the reserve air pressure in the tank.
6. **Tank Drain Valve:** Used to drain condensate from the air tank.
7. **Tank Relief Valve:** A pressure relief valve located on the side of the pressure switch. It automatically releases compressed air when the air compressor reaches cut-out pressure. Air escapes momentarily before the valve closes.
8. **Quick Connect:** Enables quick attachment and removal of the air hose.
9. **Regulator Pressure Gauge:** Displays the outgoing air pressure to the tool, controlled by the regulator.
10. **Regulator:** Controls the air pressure coming from the tank. Turn the knob clockwise to increase pressure and counterclockwise to decrease pressure.
11. **Outlet Tube:** Transfers compressed air from the pump head to the tank.
12. **Pressure Relief Tube:** Allows pump head pressure to escape to the atmosphere through the pressure relief valve, enabling the compressor to restart under a no-load condition.

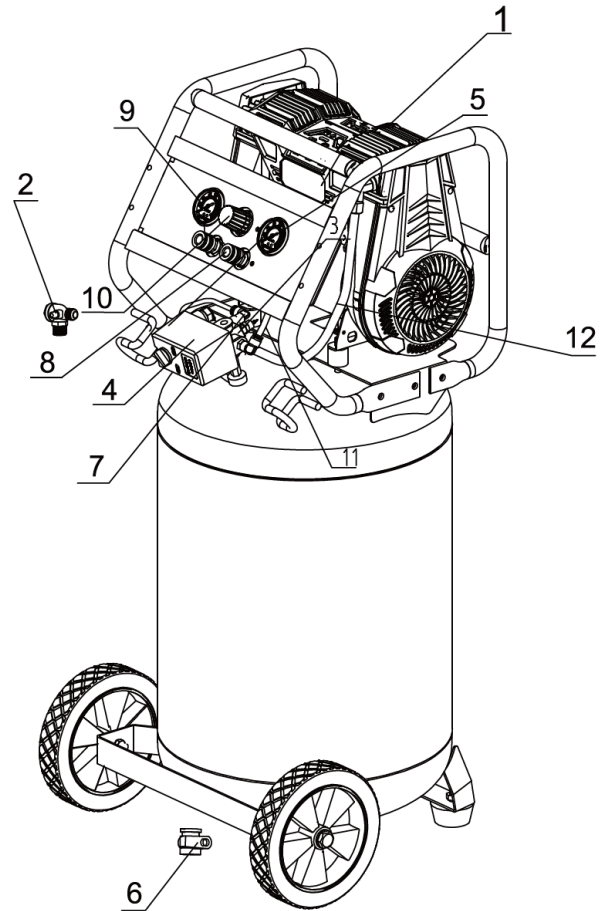

Installation & Assembly

WARNING

Before performing any maintenance, turn off the compressor, unplug it from the power source, bleed the air from the tank, and allow the unit to cool completely. Failure to follow these steps may result in personal injury from moving parts, electrical components, compressed air, or hot surfaces.

The air compressor must always be placed in a clean, dry, and well-ventilated area. Ensure there is at least 12 inches of clearance on all sides. Keep the air filter area free from debris or obstructions. Inspect the air filter daily to ensure it is clean and functioning properly.

CAUTION

This product contains an electric motor that may produce arcs and sparks during operation. Do not use or store this product near flammable liquids or vapors. It is not designed for installation or use in commercial garages or shop environments.

Grounding Instructions

This product must be properly grounded. Grounding reduces the risk of electric shock in the event of a short circuit by providing a safe path for electrical current. The power cord is equipped with a grounding wire and an appropriate grounding plug (see figure below). Ensure the plug is inserted into an outlet that is correctly installed and grounded in compliance with all local codes and regulations.

WARNING

Improper installation of the grounding plug poses a risk of electric shock. If the power cord or plug requires repair or replacement, do not connect the grounding wire to either flat blade terminal. The grounding wire is identified by insulation with a green outer surface, with or without yellow stripes. If the grounding instructions are unclear or you are uncertain whether the product is properly grounded, consult a qualified electrician or service technician. Do not modify the provided plug. If the plug does not fit the outlet, have a proper outlet installed by a qualified electrician.

This product is designed for use on a circuit with a nominal rating of 120 volts. It comes factory-equipped with a specific electric cord and plug to ensure proper connection to the correct circuit. Always ensure the outlet matches the plug configuration. Do not use an adapter with this product. If the product needs modification for use with a different type of electrical circuit, contact qualified service personnel to perform the modification.

Extension Cord Use

Use only a 3-wire extension cord equipped with a 3-blade grounding plug and a 3-slot receptacle compatible with the product's plug. Ensure the extension cord is in good condition and heavy enough to handle the current required by the product. The extension cord must not exceed 25 feet in length and must be #12 AWG. Using an undersized cord can lead to a drop in voltage, resulting in power loss and potential overheating.

Breaking-In Procedures

No break-in procedure is required for this product. It has been factory tested to ensure proper operation and performance.

Daily Start-Up Procedures

1. **Inspect the Compressor:** Check for any visible damage, loose connections, or signs of wear. Ensure all guards and covers are properly installed.
2. **Check the Air Filter:** Confirm the air filter is clean and free of debris. Replace if necessary.
3. **Drain the Tank:** Ensure the air tank is drained of any condensate from the previous use.
4. **Verify Power Source:** Ensure the compressor is connected to the correct power supply and that the grounding plug is securely connected to a grounded outlet.
5. **Inspect Hoses and Connections:** Check all air hoses and fittings for leaks or damage. Ensure they are securely attached.
6. **Ensure Proper Ventilation:** Confirm the compressor is placed in a clean, dry, and well-ventilated area with at least 12 inches of clearance on all sides.
7. **Set Regulator Pressure:** Adjust the regulator to the desired pressure for your tool or application.

Operation

8. **Turn on the Compressor:** Switch on the compressor and allow it to reach the cut-out pressure before use.
9. **Test Operation:** Check the functionality of connected tools and ensure the compressor is operating smoothly before beginning work.

Daily Shut-Down Procedures

1. **Turn Off the Compressor:** Set the Auto-On/Off lever to the Off position.
2. **Disconnect Power:** Unplug the power cord from the receptacle.
3. **Release Outlet Pressure:** Adjust the regulator to set the outlet pressure to **zero**.
4. **Detach Tools and Accessories:** Remove any connected air tools or accessories.
5. **Reduce Tank Pressure:** Pull the safety valve ring until the tank pressure gauge reads below **20 PSI**.
6. **Drain the Tank:** With the tank pressure below **20 PSI**, open the drain valve to release water condensate and air from the tank. After the tank is fully bled, close the drain valve to prevent debris buildup.

⚠ CAUTION

When draining the tank, always wear appropriate ear and eye protection. Perform the drainage in a suitable location, as water condensate is typically present during the process.

⚠ WARNING

Water left in the tank during storage can lead to tank rupture. To prevent serious injury, always drain the tank thoroughly after each use.

Maintenance

NOTICE

Any service procedures not outlined in the maintenance schedule must be performed by qualified service personnel.

⚠ CAUTION

Before performing any maintenance, turn off the air compressor, unplug it from the power source, bleed the air from the tank, and allow the unit to cool completely.

⚠ WARNING

To ensure efficient operation and extend the life of the air compressor, a routine maintenance schedule should be followed. The maintenance schedule provided is designed for consumers using the compressor in a typical working environment.

Daily Shut-Down Procedures

Check the safety valve as follows:

1. **Reach Cut-Out Pressure:** Plug in the compressor and allow it to run until it reaches cut-out pressure.
2. **Release Pressure:** While wearing safety glasses and hearing protection, pull the safety valve ring to release air pressure from the tank.
3. **Observe Safety Valve Function:** The safety valve should automatically close at approximately **40-80 PSI**. If the safety valve fails to release air when the ring is pulled, or if it does not close automatically, the valve must be replaced immediately.

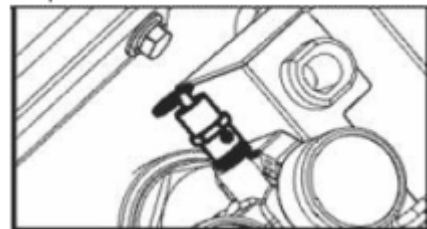

Maintenance

Air Filter Cleaning

Occasionally, the air filter should be removed and cleaned. Follow these steps:

1. **Charge the Tank:** Charge the tank with compressed air, then turn off the compressor and unplug it.
2. **Remove the Air Filter Cover:** Turn the air filter cover counterclockwise to remove it from the air filter compartment.
3. **Remove the Air Filter:** Take the air filter out of the air filter housing.
4. **Clean the Air Filter:** Use compressed air to blow through the air filter for 10-15 seconds to remove dust and debris.
5. **Reassemble:** Place the air filter back into the housing and secure the cover by turning it clockwise.

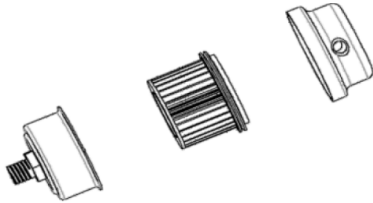

Maintenance Schedule

Items to Check/Change	Frequency
Check Tank Safety Valve	Each Use
Overall Unit Visual Check	Daily
Check Air Intake Filter	Each Use
Drain Tank	Weekly
Check Power Cord for Damage	Each Use

Storage Instructions

Follow these steps when storing the air compressor:

1. **Turn Off and Unplug:** Switch off the unit and unplug the power cord from the receptacle.
2. **Detach Accessories:** Remove all air hoses, accessories, and air tools from the air compressor.
3. **Complete Daily Maintenance:** Perform the daily maintenance procedures as outlined in the manual.
4. **Release Tank Pressure:** Pull the safety valve ring until the tank pressure drops to approximately 20 PSI.
5. **Drain the Tank:** Open the drain valve to release all remaining air and moisture from the tank.
6. **Close the Drain Valve:** Once the tank is completely drained, close the drain valve to prevent debris buildup.
7. **Store Properly:** Place the air compressor in a clean, dry location to protect it from dirt and moisture.

Troubleshooting Guide

Problem	Possible Causes	Probable Solutions
COMPRESSOR FAILS TO START	Power source issue, blown fuse, or tripped circuit breaker	Check if the power cord is properly plugged in. Verify outlet functionality. Reset circuit breaker or replace fuse with a time-delay type. Avoid using extension cords.
COMPRESSOR STARTS, BUT DOESN'T BUILD PRESSURE	Air leaks, faulty pressure switch, or worn piston seal	Inspect hoses, fittings, and connections for air leaks using soapy water; repair any leaks. Ensure pressure relief valve and petcock are closed. If persistent, seek technician assistance.
EXCESSIVE NOISE OR VIBRATION	Loose parts, worn bearings, or improper surface	Ensure compressor is on a stable, level surface. Check and tighten any loose bolts, nuts, or fittings. If the noise continues, bearings may need servicing.
COMPRESSOR RUNS CONTINUOUSLY WITHOUT REACHING THE NORMAL PSI	Air leak, damaged tank, or faulty pressure switch	Check for air leaks with soapy water and repair as needed. Inspect a tank for damage or corrosion. If there is no leak, pressure switch may need adjustment or replacement.
AIR PRESSURE DROPS QUICKLY	Leak in the tank, fittings, or attached tools	Inspect all connections and tanks for leaks. Tighten or replace faulty connections and ensure tools are properly connected and functioning.
MOTOR OVERHEATS	Overloading, lack of ventilation, or continuous use	Allow the compressor to cool between uses. Ensure well-ventilated area, keeping unit 12 inches from walls. Avoid continuous use at maximum PSI.
PRESSURE RELIEF VALVE ENGAGES FREQUENTLY	Over pressurization, faulty pressure switch, or blocked valve	Inspect pressure switch for correct settings. Check relief valve for obstructions and clean if needed. If the issue persists, consult technician for switch replacement.

Specifications

Product Description	26 Gallon Oil-free Super Quiet Air Compressor
Oil Type	Oil-free
Configuration	Vertical
Tank Capacity (gallon)	26 Gallon
SCFM @ 90PSI	4.3
SCFM @ 40PSI	5.3
Peak Power (hp)	2.5
Rated Power (hp)	2.0
Max Pressure (psi)	175
Cut-in Pressure (psi)	145
Cut-out Pressure (psi)	175
Pressure Gauges	2
Quick Connect Coupler	2PC, Universal, NPT1/4
Wheels	10" 2PCS Solid
Unit Size (inch)	18.3"x17.9"x51.1"
Unit Weight (lbs.)	119
Warranty	1 Year P&L

Exploded View

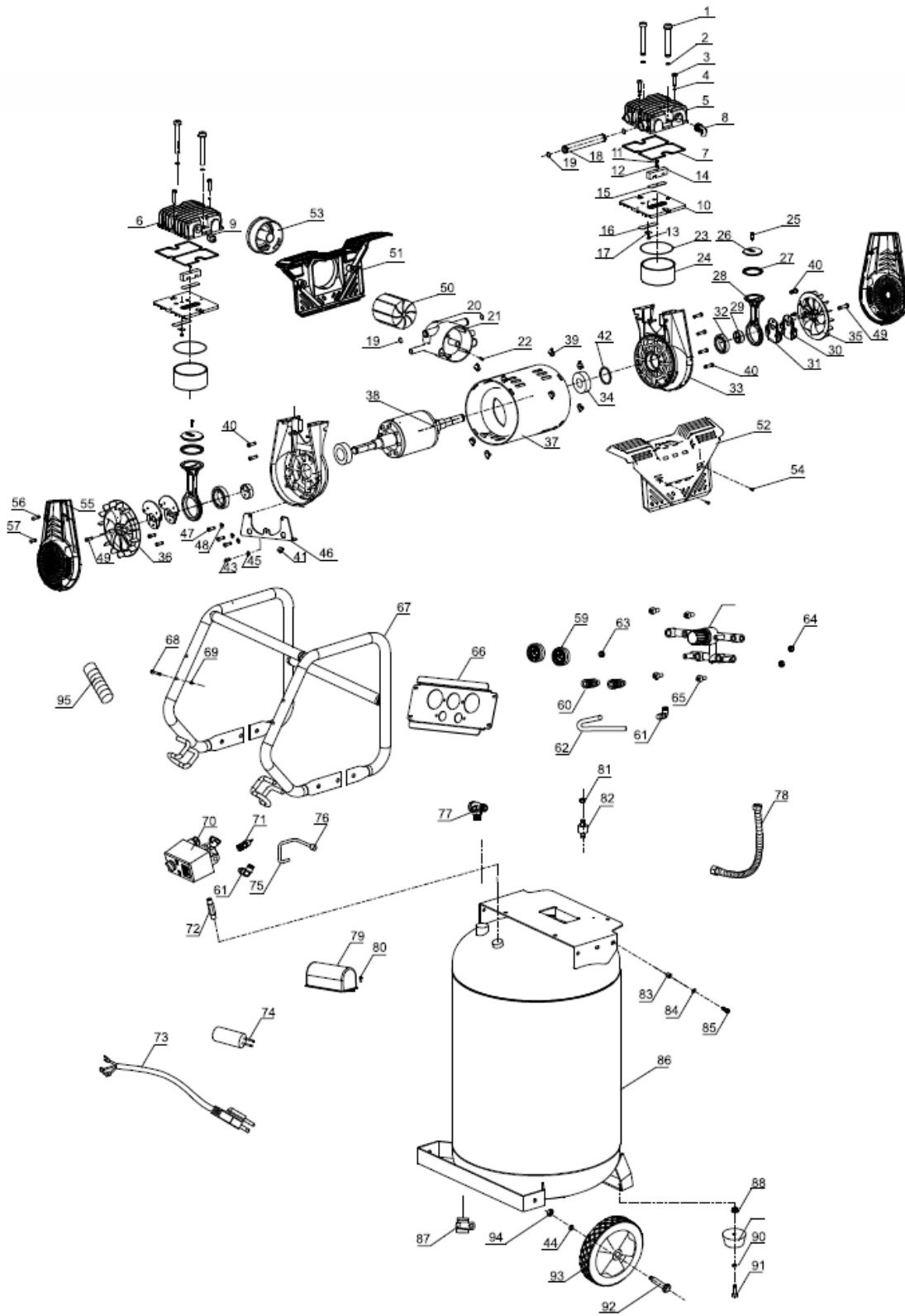

Parts List

NUM	PART #	SPECIFICATION	QTY
1	45.391B	Screw M10X45	4
2	45.090	Spring Washer M10	4
3	45.132	Bolt M5X20	4
4	45.093	Spring Washer M5	16
5	03.185	Cylinder Head 1	1
6	03.187	Cylinder Head 2	1
7	36.125	Gasket of Cylinder Head	2
8	40.004D	Exhaust Elbow	1
9	40.108C	Relief Valve	1
10	03.186	Valve Plate	2
11	45.112	Screw M4X10	2
12	45.094	Spring Washer M4	2
13	45.285A	Screw M4X6	2
14	02.351	Limitation	2
15	34.085	Outlet Valve Reed	2
16	34.086	Inlet Valve Reed	2
17	34.087	Press Of Inlet Valve Reed	2
18	03.376	Connect Tube	1
19	46.350	Gasket of Connect Tube	4
20	06.829	Filter Front Seat	1
21	06.830A	Filter Rear Seat	1
22	45.260	Screw ST4.2X12	4
23	36.122	O-Ring Of Cylinder	2
24	10.080	Cylinder	2
25	45.342A	Screw M6X25	2
26	03.355	Cover Of Connect Rod	2
27	29.052	Piston Ring	2
28	03.354	Connect Rod	2
29	12.055A	Eccentric	2
30	12.056	Balance 1	2
31	12.057	Balance 2	2
32	31.053	Bearing 6908	2
33	03.353A	Crankcase	2
34	31.023	Bearing 6204	2
35	06.696	Fan (Left)	1
36	06.697	Fan (Right)	1
37	04.416	Stator	1
38	04.417	Rotor	1
39	04.600	Motor Buckle	8

40	45.343	Screw M5X22	12
41	21.040	Strain Relief	1
42	46.003	Wave Spring Washer 204	1
43	45.112C	Screw M4X10	1
44	45.229	Spring Washer M8	2
45	45.058	Lock Washer4	1
46	20.048A	Pump Fixture	2
47	45.140C	Screw M6X20	6
48	45.092	Spring Washer M6	6
49	45.133	Screw M5X25	2
50	41.080A	Filter	1
51	06.220A	Filter Mask Left	1
52	06.219A	Filter Mask Right	1
53	41.830	Filter Cover	1
54	45.409A	Screw ST4.2X15	4
55	06.821	Pump Cover	2
56	45.415	Screw M4×20	4
57	45.112	Screw M4×10	2
58	25.502	Regulator Manifold	1
59	23.507	Pressure Gauge	2
60	42.080	Quick Coupler	2
61	42.099A	Elbow 90°	2
62	31.036	Nylon Hoseφ8*215	1
63	42.029A	Plug NPT1/4	2
64	42.030D	Plug NPT1/8	5
65	45.366	Screw M5X12	4
66	20.047A	Regulator Panel	3
67	20.523A	Handle Frame φ25X1.0	1
68	45.335D	Screw M5X35	4
69	45.107B	Nut M5	4
70	21.014A	Pressure Switch	1
71	24.003A	Safety Valve	1
72	42.067A	Connect NPT1/4*55	1
73	22.005	Power Cord SJT14#X2m	1
74	27.014	Capacitor	1
75	43.700A	Relief Tube φ6×280	1
76	44.002B	Relief Nut M10x1	1
77	38.003	Check Valve	1
78	43.813	Pressure Hose	1
79	18.025E	Capacitor Cover	1
80	45.286A	Screw M4x8	2
81	45.106	Nut M8	4

82	15.081	Bolt M8×17	4
83	45.086B	Rivet Nut M8X11	6
84	45.067	Washer φ6	6
85	45.140	Screw M6X20	6
86	08.760	Tank	1
87	39.020	Drain Valve	1
88	45.291	Nut M8	2
89	15.022	Rubber Foot	2
90	45.064	Washerφ8	2
91	45.044	Screw M8×30	2
92	46.043	Axle	2
93	15.034A	10" Wheel	2
94	45.231	Nut M8	2
95	37.007A	Handle Grip	1



For product questions or to order replacement parts, please call 1-866-591-8921 or email support@pulsar-products.com.

Goodyear (and Winged Foot Design) are trademarks of or licensed to The Goodyear Tire & Rubber Company or Goodyear Canada Inc. used under license by Pulsar Products Inc., 8676 Rochester Ave., Rancho Cucamonga, CA 91730. © 2024 The Goodyear Tire & Rubber Company.