

## Operator's Manual

### 8-Gallon Oil-free Air Compressor

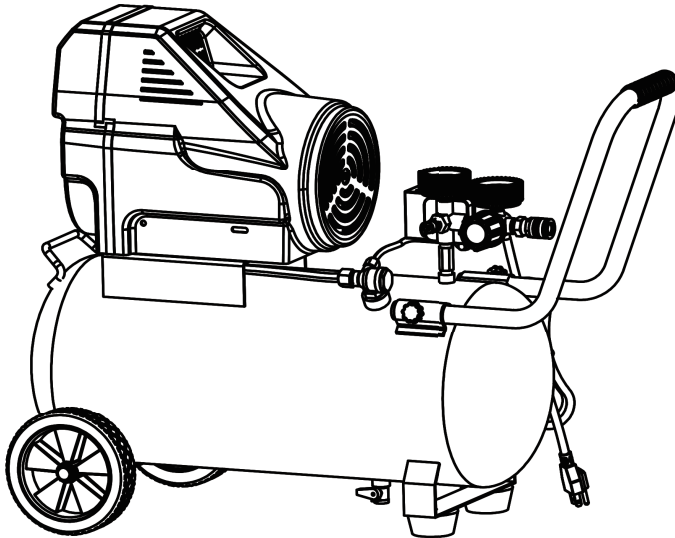

**CAUTION:** Before using this product, read this manual and follow all its Safety Rules and Operating Instructions.

**STOP**

**DO NOT RETURN TO STORE!**

HAVE QUESTIONS OR NEED SERVICE?



866-591-8921



# TABLE OF CONTENTS

	Page
Warranty . . . . .	see below
Safety Symbols . . . . .	.3
Important Safety Instructions & Guidelines . . . . .	.3
Specifications . . . . .	.4
Glossary . . . . .	.4
Parts & Features . . . . .	.5
Installation & Assembly . . . . .	.6
Operating Procedures . . . . .	.7
Maintenance . . . . .	.8
Storage . . . . .	.8
Troubleshooting Guide . . . . .	.9
Exploded Views . . . . .	10
Parts Lists . . . . .	11 & 12
Service Number . . . . .	Back Cover



## GOODYEAR LIMITED WARRANTY





**1 Year** – Limited on single-cylinder, oil-free compressors. This warranty is not transferable to subsequent owners.

**2 Year** - Limited on oil-lubricated and 'silent' air compressors. This warranty is not transferable to subsequent owners.

With proof of sale, please call 1-866-591-8921 for technical support, spare parts, or warranty related issues. **DO NOT RETURN THE PRODUCT TO THE STORE.** This warranty applies for only 30 days from the date of sale if this product is ever used while providing commercial services or if rented to another person. This warranty gives you specific legal rights, and you may also have other rights which vary from state to state.

## Safety Instruction

The information listed below should be read and understood by the operator. This information is given to protect the user while operating and storing the air compressor. We use the symbols below to allow users to recognize important information about their safety.





<p style="text-align: center;"> <b>DANGER!</b></p> <p>Indicates an imminently hazardous situation which, if not avoided, will result in death or serious injury.</p>	<p style="text-align: center;"> <b>CAUTION!</b></p> <p>Indicates a potentially hazardous situation which, if not avoided, may result in minor or moderate injury.</p>
<p style="text-align: center;"> <b>WARNING!</b></p> <p>Indicates a potentially hazardous situation which, if not avoided, could result in death or serious injury.</p>	<p style="text-align: center;"> <b>NOTICE</b></p> <p>Indicates a potentially hazardous situation which, if not avoided, may result in property damage.</p>





## Important Safety Instructions and Guidelines

### Save all instructions

 **WARNING!** This product can expose you to chemicals including Lead and DEHP, which are known to State of California to cause cancer, birth defects or other reproductive harm. Wash hands after handling. For more information go to [www.P65Warnings.ca.gov](http://www.P65Warnings.ca.gov).

Improper operation or maintenance of this product could result in serious injury and/or property damage. Read and understand all of the warnings and safety instructions provided before using this equipment.

<b>NOTICE</b>	The air compressor should be operated on a dedicate 20 Amp circuit. If the circuit does not have 20 free Amps available, a larger circuit must be used. Always use more air hose before utilizing extension cords. All extension cords used must be 12 gauge with a maximum length of 25 ft. The circuit fuse type must be a time delay. Low Voltage could cause damage to the motor.
<b>Risk of Moving Parts</b> 	All guards and covers must be installed correctly whenever the air compressor is in operation. If any guard is missing or damaged, do not use the air compressor until it has been repaired by authorized personnel. The power cord should be free of kinks, bends, or other damage, use extra caution when storing the equipment.
<b>Risk of Burns</b> 	There are surfaces on your air compressor that, while in operation and thereafter, can cause serious burns if touched. The equipment should be allowed time to cool before any maintenance is attempted. Items such as the compressor pump and the outlet tube are normally hot during and after operation.
<b>Risk of Falling</b> 	Operation of the air compressor should always be in a position that is stable. Never use the air compressor on a rooftop or elevated position that could allow the unit to fall or be tipped over. Use additional air hose for elevated jobs.
<b>Risk from Flying Objects</b> 	NEVER direct compressed air or point any nozzle or sprayer toward any part of the body, people, or animals. Turn off the air compressor and drain the air tank before performing any type of maintenance or disassembly of the hoses or fittings. Never point any nozzle or sprayer toward any part of the body or at other people or animals.

<p><b>Risk to Breathing</b></p> 	<p>Avoid using the air compressor in confined areas. Always have adequate space (12 inches) on all sides of the air compressor. Also keep children, pets, and others out of the area of operation. This air compressor does not provide breathable air for anyone or any auxiliary breathing device. Spraying material will always need to be in another area away from the air compressor to not allow intake air to damage the air compressor filter.</p>
<p><b>Risk of Electrical Shock</b></p> 	<p>Never utilize the air compressor in the rain or wet conditions. Any electrical issues or repairs should be performed by authorized personnel such as an electrician and should comply with all national and local electrical codes. The air compressor should also have the proper three prong grounding plug, correct voltage, and adequate fuse protection.</p>
<p><b>Risk of Explosion or Fire</b></p> 	<p>Never operate the compressor near combustible materials, gasoline or solvent vapors. If spraying flammable materials, locate the air compressor at least 20 feet away from the spray area. Never operate the air compressor indoors or in a confined area.</p>
<p><b>Risk of Bursting</b></p> 	<p>Always drain the air compressor tank daily or after each use. If the tank develops a leak, then replace the air compressor. Never use the air compressor after a leak has been found or try to make any modifications to the tank. Never modify the air compressor's factory settings which control the tank pressure or any other function.</p>

## Specifications

Pump . . . . .	Oil-Free, Direct Drive	Air Tank Capacity . . . . .	8 Gallons
Motor . . . . .	1.5HP	Cut-in Pressure . . . . .	120 PSI
Bore . . . . .	2.48"	Cut-out Pressure . . . . .	150 PSI
Stroke . . . . .	0.87"	SCFM @ 90 PSI . . . . .	4.0
Voltage Single Phase . . . . .	120 VAC	SCFM @ 40 PSI . . . . .	5.0
Minimum Circuit Requirement . . . . .	20 Amps	Rated Current . . . . .	14.5 Amps

## Glossary

**CFM:** Cubic feet per minute.

**SCFM:** Standard cubic feet per minute; a unit of measure for air delivery.

**PSIG:** Pounds per square inch gauge; a unit of measure for pressure.

**ASME:** American Society of Mechanical Engineers.

**Cut-In Pressure:** The air compressor will automatically start to refill the tank when the pressure drops below the prescribed minimum.

**Cut-out Pressure:** The point at which the motor stops when the tank has reached maximum air pressure.

**Code Certification:** Products that bear one or more of the following marks: UL, CUL, ETL, CSA, have been evaluated by OSHA-certified independent safety laboratories and meet the applicable Underwriters Laboratories Standards for Safety.

# Installation & Assembly

## Installation & Assembly

### **⚠ WARNING!**

Before performing any maintenance, turn the compressor off, unplug from power source, bleed air from tank and allow unit to cool. Personal injuries can occur from moving parts, electrical sources, compressed air or hot surfaces.

## Installation

### Location of the Air Compressor

The air compressor should always be located in a clean, dry and well-ventilated environment. The unit should have at minimum, 12 inches of space on each side. The air filter intake should be free of any debris or obstructions. Check the air filter on a daily basis to make sure it is clean and in working order.

### **⚠ WARNING: Risk of fire or explosion**

product includes an electric motor which tends to produce arcs and sparking. Do not expose this product to flammable liquids or vapors. This product is not intended for installation or use in a commercial garage or shop environment.

### Grounding Instructions

This product must be grounded. In the event of an electrical short circuit, grounding reduces the risk of electric shock by providing an escape wire for the electric current. This product is equipped with a cord having a grounding wire with an appropriate grounding plug. (See figure below.) The plug must be plugged into an outlet that is properly installed and grounded in accordance with all local codes and ordinances. Check with a qualified electrician or service personnel if these instructions are not completely understood or if in doubt as to whether the tool is properly grounded.

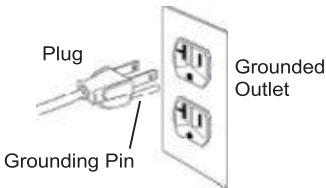

**⚠ WARNING!** Improper installation of the grounding plug will result in a risk of electric shock. If repair or replacement of the cord or plug is necessary, do not connect the grounding wire to either flat blade terminal. The wire with insulation having an outer surface that is green with or without yellow stripes is the grounding wire. Check with a qualified electrician or service person if the grounding instructions are not completely understood, or if you are in doubt as to whether the product is properly grounded. **Do not modify the plug provided;** if it will not fit the outlet, have the proper outlet installed by a qualified electrician.

This product is for use on a circuit having a nominal rating of 120 Volts and is factory-equipped with a specific electric cord and plug to permit connection to a proper electric circuit. Make sure that the product is connected to an outlet having the same configuration as the plug. No adapter should be used with this product. If the product must be reconnected for use on a different type of electric circuit, qualified service personnel should make the reconnection.

### Extension Cords

Use only a 3-wire extension cord that has a 3-blade grounding plug, and a 3-slot receptacle that will accept the plug on the product. Make sure your extension cord is in good condition. When using an extension cord, be sure to use one heavy enough to carry the current your product will draw. Cords must not exceed 25 feet and # 12 AWG must be used. An undersized cord will cause a drop in line voltage resulting in loss of power and overheating.

### Break-In Procedures

No break-in procedure is required by the user. This product is factory tested to ensure proper operation and performance.'

## Parts & Features

See figures below for reference.

1. **Air Intake Filter** – Provides clean air to the pump and must always be kept free of debris. Check on a daily basis or before each use.
2. **Check valve** – When the pump is not in operation, the valve closes to retain air pressure inside the tank. An internal component.
3. **Tank Safety Valve** – Used to allow excess tank pressure to escape into the atmosphere. This valve should only open when the tank pressure is above the maximum rated pressure.
4. **Pressure Switch** – This controls the power to the motor and also the cut-in/cut-out pressure settings. This switch serves as the Auto-On/Off positions for the unit.
5. **Tank Pressure Gauge** – Indicates the reserve air pressure in the tank.
6. **Tank Drain Valve** – Used to drain condensation from the air tank
7. **Pressure Relief Valve** – The pressure relief valve located on the side of the pressure switch, is designed to automatically release compressed air when the air compressor reaches cut-out pressure. The released air should only escape momentarily and the valve should then close.
8. **Quick Connect** – Offers a quick release feature for attaching and removing the air hose.
9. **Regulator Pressure Gauge** – Indicates the outgoing air pressure to the tool and is controlled by the regulator.
10. **Regulator** – The pressure coming from the air tank is controlled by the regulator. To increase the pressure, turn the knob clock wise, and to decrease the pressure, turn the knob counterclockwise.
11. **Outlet Tube** – Carries **compressed air from the pump head to the tank**.
12. **Pressure relief tube** – **Allows pump head pressure to escape to atmosphere through the pressure relief valve, so the compressor restarts under a no-load condition.**

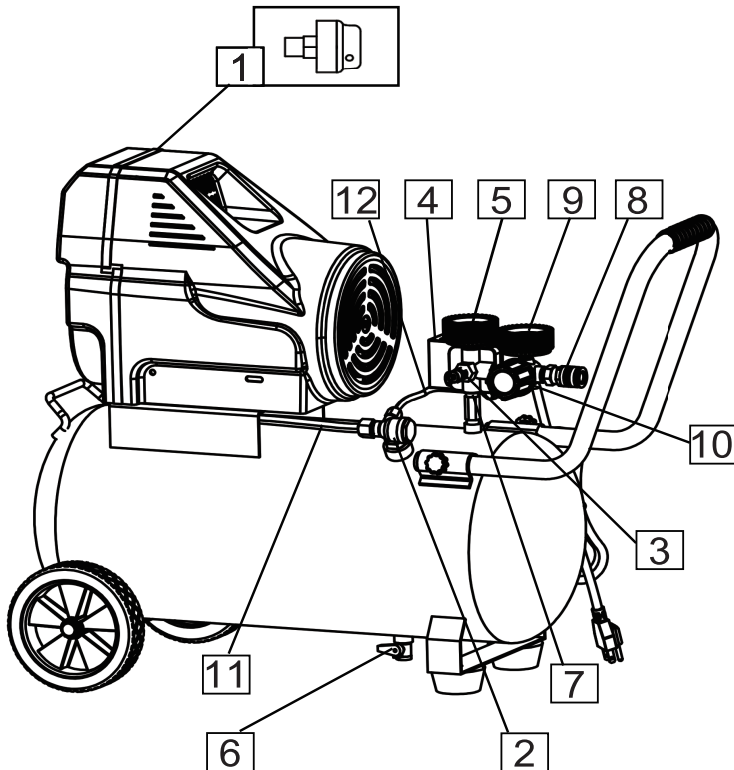

# Operation

## Daily Start-Up Procedures

1. Set the Auto-On/Off lever to the Off position.
2. Inspect the air compressor, air hose, and any accessories or tools being used for damage or obstruction. If any of these items need repair or replacement, contact customer service at 1-866-591-8921.
3. Close the drain valve (closed position shown; turn switch vertical to open).
4. Connect the air hose to the quick connect socket on the regulator assembly by inserting the quick connect plug on the air hose into the quick connect socket. The quick connect socket collar will snap forward and lock the plug into place to provide an airtight seal.
5. Plug the power cord into the proper receptacle.
6. Turn the Auto-On/Off lever to the On-Auto position and the compressor will start and build air pressure in the tank to cut-out pressure and then shut off automatically.
7. Adjust the regulator to a PSI setting that is needed for your application and be sure it is within the safety standards required to perform the task. If using a pneumatic tool, the manufacturer should have recommendations in the manual for that particular tool on operating PSI settings.
8. The air compressor is now ready for use.

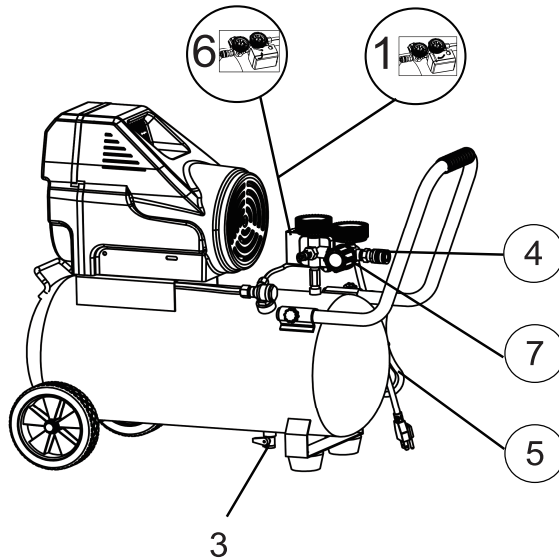

## Daily Shut-Down Procedures

1. Set the Auto-On/Off lever to the Off position.
2. Unplug the power cord from the receptacle.
3. Set the outlet pressure to zero on the regulator.
4. Remove any air tools or accessories..
5. Pull the safety valve pull ring until the tank pressure gauge reads about 20 psi.
6. Only with the tank pressure below 20 psi. Open the drain valve, allowing air to bleed from the tank. After all of the air has bled from the tank, close the drain valve to prevent debris buildup in the drain valve.

## ⚠ CAUTION!

When draining the tank, always use ear and eye protection. Drain the tank in a suitable location; condensation will be present in most cases of draining.

## ⚠ WARNING!

Water that remains in the tank during storage cause the tank to rupture. To avoid serious injury, be sure to drain the tank after each use or daily.

## Maintenance

**NOTE:** Any service procedure not covered in the maintenance schedule should be performed by **qualified service personnel**. Contact customer service at 1-866-591-8921.

### **⚠ WARNING!**

Before performing any maintenance, turn air compressor off, unplug it from the power source, bleed air from the tank and allow the unit time to cool.

### **⚠ CAUTION!**

To ensure efficient operation and longer life of the air compressor, a routine maintenance schedule should be followed. The maintenance schedule shown to the right is intended for a consumer whose compressor is used in a normal working environment on a daily basis.

<b>Maintenance Schedule</b>	
<b>Items to Check/Change</b>	<b>Before each use or daily</b>
Check Tank Safety Valve	Each Use
Overall Unit Visual Check	Daily
Check Air Intake Filter	Each Use
Drain Tank	Daily
Check Power Cord for Damage	Each Use

### **Tank Safety Valve Check**

Check the safety valve as follows:

1. Plug the compressor in and run until cut-out pressure is reached.
2. Wearing safety glasses, pull out on the safety valve ring to release pressure from the tank.
3. The safety valve should close automatically at approximately 40-80 PSI. If the safety valve does not allow air to be released when pull out on the ring, or does not close automatically, it must be replaced.

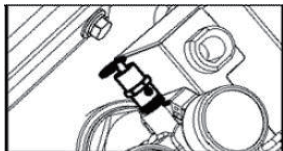

### **Storage**

When storing the air compressor, be sure to do the following:

1. Turn the unit off and unplug the power cord from the receptacle.
2. Remove all air hoses, accessories, and air tools from the air compressor.
3. Perform the daily maintenance schedule.
4. Open the safety valve pull ring until the tank pressure is about 20 psi.
5. Open the drain valve to bleed all air from the tank.
6. Close the drain valve.
7. Store the air compressor in a clean and dry location.

### **Air Filter Cleaning**

Occasionally the air filter needs to be removed and cleaned.

1. Turn the compressor off and unplug it from electrical outlet.
2. Turn the air filter cover counterclockwise to remove from air filter compartment.
3. Remove air filter from air filter housing.
4. Blow compressed air through the air filter for 10-15 seconds.
5. Return filter and cover into place.

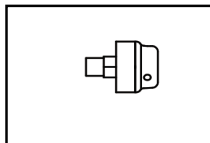

## Troubleshooting Guide

### ⚠ WARNING!

The air compressor should be turned off and unplugged from the receptacle before any maintenance is performed as well as the air bled from the tank and the unit allowed time to cool. Personal injuries could occur from moving parts, electrical sources, compressed air, or hot surfaces.

PROBLEM	POSSIBLE CORRECTION
Air leaks at the check valve or at the pressure relief valve.	A defective check valve results in a constant air leak at the pressure relief valve when there is pressure in the tank and the compressor is shut off. Drain the tank, then remove and clean or replace the check valve.
Air leaks between head and cylinder.	Inspect for proper torque on head bolts. If leak remains, contact customer service at 1-866-591-8921.
Air leak from tank safety valve.	Operate the tank safety valve manually by pulling on the ring. If the valve continues to leak when in the closed position, it should be replaced.
Pressure reading on the regulated pressure gauge drops when an accessory is used.	If there is an excessive amount of pressure drop when the accessory is used, replace the regulator. <b>NOTE:</b> Adjust the regulated pressure under flow conditions (while accessory is being used). It is normal for the gauge to show minimal pressure loss during initial use of the tool.
Excessive tank pressure.	Move the Auto-On/Off lever to the Off position. If the unit doesn't shut off, unplug it from the receptacle and contact customer service at 1-866-591-8921
Motor will not start.	Make sure power cord is plugged in and the On/Off lever is turned on. If the circuit breaker trips, make sure the circuit and the breakers are rated for 15 amps, contact a technician if necessary.
	Make sure the Thermal Overload Switch has not tripped. The motor has a built-in thermal cut out that trips when necessary to protect the motor from damage when overheated.  To reset the motor overload turn the pressure switch Auto/Off lever to the Off position and unplug the unit from the power outlet. Allow 10 minutes minimum for motor overload cut-out to cool and reset. Unit can then be plugged in and restarted.
Thermal overload protector cuts out repeatedly	<ol style="list-style-type: none"> <li>1. Lack of ventilation, room temperature too high. Move to cooler environment.</li> <li>2. Excessive air usage, compressor too small for the application. Lower the rate of consumption.</li> </ol>
Excessive moisture in the discharge air.	Remove the water in the tank by draining after each use. High humidity environments will cause excessive condensation. Utilize water filters on your air line. <b>NOTE:</b> Water condensation is not caused by compressor malfunction. Be sure the compressor's air output is greater than your tool's air consumption rate.
Air leaks from the tank body or tank welds.	Never drill into, weld or otherwise modify the air tank or it will weaken. The tank can rupture or explode. Compressor tanks cannot be repaired. Discontinue use of the air compressor.

# Exploded View

## GoodYear Air Compressor Model GYC6080S

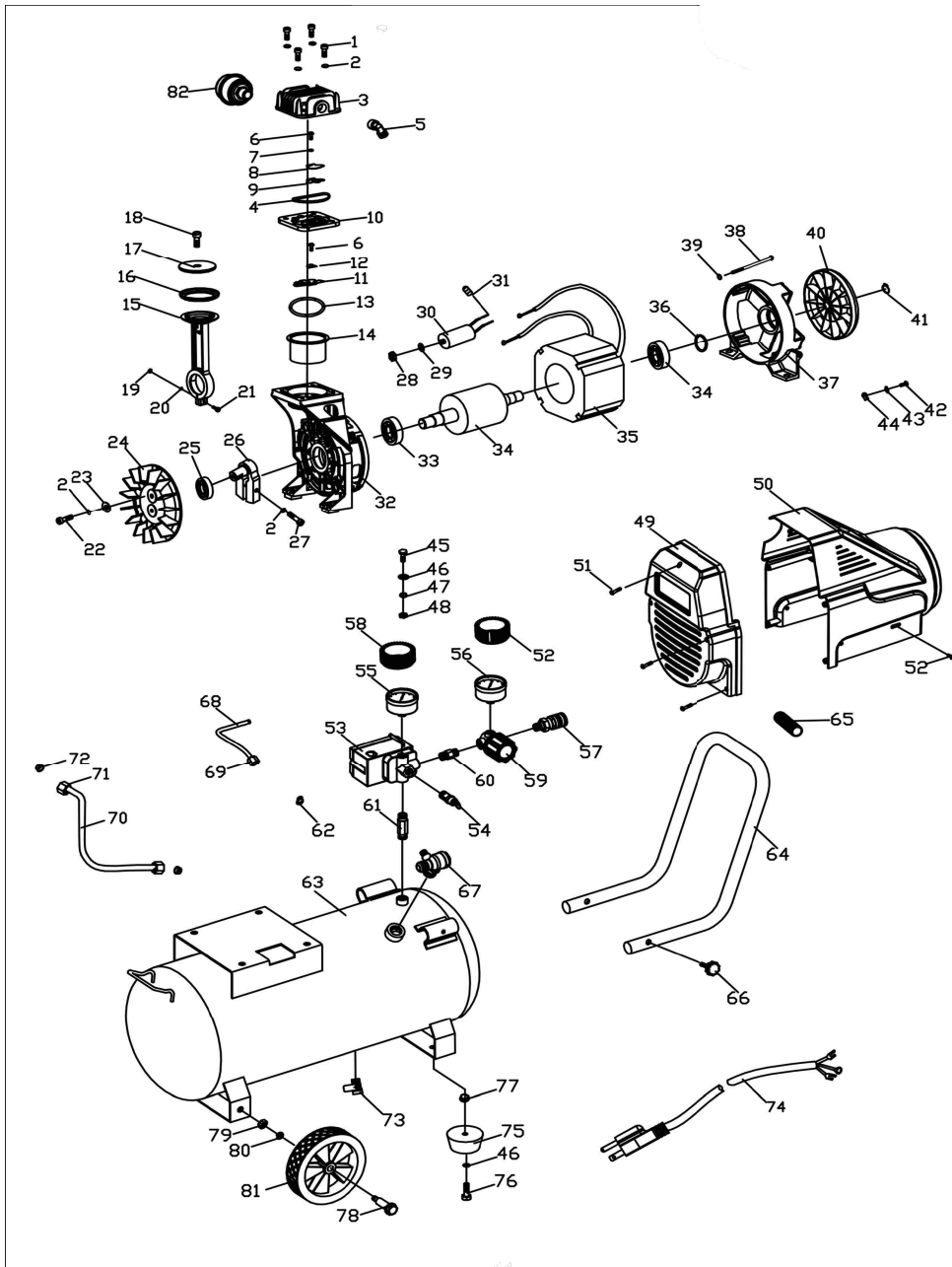

## Part

Ref.#	Part#	Description	Qty
1	45.143A	Screw M6×35 GB/T70	4
2	45.092	Lock Washer6 GB/T93	5
3	03.254	Cylinder Head	1
4	36.040	O- Ring, D shape	1
5	40.202B	Elbow ZG1/2-G3/8	1
6	45.111	Screw	2
7	45.094	Lock Washer6 GB/T93	1
8	34.016	Exhaust Valve Limiter	1
9	34.020	Exhaust Reed Valve	1
10	03.255	Valve Plate	1
11	34.021	Inlet Reed Valve	1
12	34.015	Inlet valve retainer	1
13	36.041	O- Ring, High Temperature	1
14	03.047A	Cylinder φ63×45	1
15	03.250	Connecting Rod	1
16	29.030	Piston Ring	1
17	03.251	Piston Cap	1
18	45.327	Screw M6×16 GB/T70 EG	1
19	45.080	Hex Nut GB/T41	1
20	45.093	Lock Washer5 GB/T93	1
21	45.133	Screw M5×25 GB/T70	1
22	45.325	Screw M6×16-LH GB/T70	1
23	45.072	Waher, 6 GB/T96	1
24	06.164	Nylon Fan φ130	1
25	31.023	Deep Groove Ball Bearing	1
26	12.035	Eccentric	1
27	45.269A	Screw M6×40 GB/T70	1
28	45.231A	Screw M8	1
29	45.066	Washer, 8mm	1
30	27.046	Capacitor	1
31	47.1226A	Wire Connector	2
32	03.256	Crankcase	1
33	31.022	Bearing 6203-2RS	2
34	04.244D	Rotor	1
35	04.020D	Stator	1
36	46.002	Wavy Washer	1
37	09.086A	Rear Motor Housing	1
38	45.031	Screw, Motor Assembly	4
39	45.093	Lock Washer,5mm GB/T93	4
40	06.018B	Fan	1
41	46.010	Snap Ring	1
42	45.203	Screw M4×6 GB/T823	1
43	45.058	Washer, 4mm	1
44	46.066	Grounding Identification	1

45	45.151A	Bolt M8×30 GB/T70	4
46	45.064	Washer, 8mm GB/T97	8
47	45.106	Nut	4
48	36.016	Motor Isolator	4
49	06.110	Front Shroud	1
50	06.111	Rear shroud	1
51	45.296	Screw, Shroud	5
52	45.085C	Screw, M5×12mm GB/T5787	4
53	21.033	Pressure Switch (120-150PSi)	1
54	24.021	Safety Valve	1
55	23.067	Pressure Gauge (NPT1/4 0-270Psi)	1
56	23.066	Pressure Gauge (NPT1/8 0-270Psi)	1
57	42.080	Quick Connect	1
58	34.044	Cover for Gauge	2
59	25.004C	Regulator	1
60	42.026e	Pipe Nipple, ZG1/4×30mm	1
61	42.028	Pipe Nipple, 1/4NPT×48mm	1
62	21.010A	Strain Relief Bushing	2
63		Tank	1
64	18.021	Handle	1
65	37.008B	Grip $\phi 22 \times 115$	1
66	06.051	Screw M6×30	2
67	38.031	Check Valve	1
68	43.017E	Pressure Relief Tube	1
69	44.002A	Nut M10	1
70	43.210	Outlet Tube	1
71	44.003	Nut G3/8	2
72		Compression Washer, 10mm	2
73	39.020	Drain Valve	1
74	22.005C	Power Cord	1
75	15.014	Isolator	2
76	45.228	Screw, M8	2
77	45.291	Nut M8	2
78	46.039B	Axle M10	2
79	45.076	Nut M10	2
80	45.090	Lock Washer, 10mm GB/T93	2
81	15.004B	Wheel	2
82	41.042	Air Filter	1







For product questions or  
to order replacement parts call

1-866-591-8921