

PRORUN®

GAS///

Operator's Manual

CHAINSAW

MODELS: PCS114, PSC214

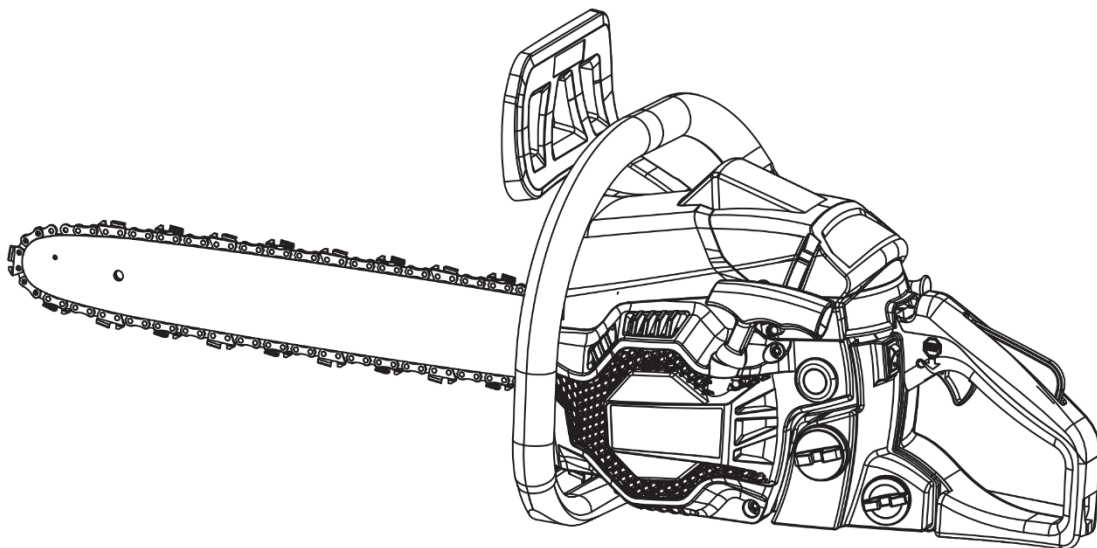

Everything PRORUN

Before operating, read the instructions.

⚠ **IMPORTANT - READ CAREFULLY BEFORE USE**

⚠ **IMPORTANT SAFETY INSTRUCTIONS - SAVE THESE INSTRUCTIONS**



WARNING: To reduce the risk of injury, the user must read and understand the Operator's Manual before using this product. Save these instructions for future reference.

Please let us know what you think.
To leave a review and see our full line of products, visit:

proruntools.com ★ ★ ★ ★ ★

1-844-905-0882, info@proruntech.com

Version: C - Issue Date: 2025/02/01

1. PRODUCT SPECIFICATIONS

Models	PCS114, PCS214
Engine Displacement	37.2 cc
Engine Type	Single Cylinder 2-stroke
Cooling System	Forced air cooled
Fuel Type	87+ octane stabilizer-treated unleaded gasoline containing no more than 10% ethanol (E10) mixed with 2-Stroke oil (see below)
Fuel Capacity	13.2 fl. oz. (390ml)
Oil Type	2-Stroke oil must meet either JASO M345 FD or ISO-L-EGD requirements for air-cooled engines, synthetic
Gasoline / Oil Ratio	50:1 gas-to-oil ratio: 20 ml oil per 1 liter gasoline (2.56 oz oil per gal of gasoline)
Bore x Stroke	1.53 in X 1.22 in (39 mm X 31.1 mm)
Compression Ratio	7.5:1
Spark Plug Type	Champion® RCJ7Y Bosch® L8RTF NGK® BPMR7A
Gap	0.02 inches (0.508 mm)
Speed Idle	3000±400RPM
Saw Chain Length	14 inches (355.6 mm)
Pitch	0.375 inch
Gauge	0.050 inch
Saw Chain Model	Oregon 91P053X, PRORUN 30001960
Guide Bar Length	14 inches (355.6 mm)
Guide bar Model	Oregon 140SDEA041, PRORUN 30028996
Lubrication Type	Bar and chain oil
Lubrication Capacity	7.1 fl. oz. (210 ml)

2. TABLE OF CONTENTS

1. PRODUCT SPECIFICATIONS.....2

2. TABLE OF CONTENTS.....3

3. IMPORTANT SAFETY INSTRUCTIONS.....4

4. GENERAL WARNINGS.....8

5. SYMBOLS.....10

6. SET UP.....11

7. CONTROLS AND OPERATIONS.....19

8. MAINTENANCE.....31

9. TROUBLESHOOTING.....39

10. EXPLODED VIEWS AND PARTS.....43

3. IMPORTANT SAFETY INSTRUCTIONS

WARNING DEFINITIONS



THIS IS THE SAFETY ALERT SYMBOL. IT IS USED TO ALERT YOU TO POTENTIAL PERSONAL INJURY HAZARDS. OBEY ALL SAFETY MESSAGES THAT FOLLOW THIS SYMBOL TO AVOID POSSIBLE INJURY OR DEATH.

⚠ DANGER! INDICATES A HAZARDOUS SITUATION WHICH, IF NOT AVOIDED, WILL RESULT IN DEATH OR SERIOUS INJURY.

⚠ WARNING! INDICATES A HAZARDOUS SITUATION WHICH, IF NOT AVOIDED, COULD RESULT IN DEATH OR SERIOUS INJURY.

⚠ CAUTION! INDICATES A HAZARDOUS SITUATION WHICH, IF NOT AVOIDED, COULD RESULT IN MINOR OR MODERATE INJURY.

⚠ IMPORTANT! GIVE DETAILS OR FURTHER INFORMATION ON WHAT HAS ALREADY BEEN SAID, WITH THE AIM OF PREVENTING DAMAGE TO THE MACHINE.

NOTE ADDRESSES PRACTICES NOT RELATED TO PERSONAL INJURY.



SAVE THESE INSTRUCTIONS

THIS MANUAL CONTAINS IMPORTANT INSTRUCTIONS THAT SHOULD BE FOLLOWED DURING SETUP, OPERATION, AND MAINTENANCE OF THE CHAINSAW.

SET UP PRECAUTIONS

1. Gasoline fuel and fumes are flammable, and potentially explosive. Use proper fuel storage and handling procedures. Do not store fuel or other flammable materials nearby.
2. Have multiple ABC class fire extinguishers nearby.
3. Operation of this equipment may create sparks that can start fires around dry vegetation. A spark arrestor may be required. The operator should contact local fire agencies for laws or regulations relating to fire prevention requirements.
4. Set up and use only on a flat, level, well-ventilated surface.
5. Wear ANSI-approved safety goggles, heavy-duty work gloves, and dust mask/respirator during use.
6. Use only lubricants and fuel recommended in the Specifications chart of this manual.

14-in, 37.2CC CHAINSAW

OPERATING PRECAUTIONS

1. Chainsaws shall be used in accordance with the operating instructions and safety precautions listed in the operator's manual(s). It shall be the responsibility of the owner to see that such instructions and precautions are given to every operator who uses the saw.
2. Keep children away from the equipment, especially while it is in use.
3. Keep all spectators at least six feet from the Engine during operation.
4. Fire Hazard! Do not fill the fuel tank while the engine is running. Do not operate if gasoline has been spilled. Clean spilled gasoline before starting the engine. Do not operate near pilot light or open flame.
5. Do not touch the engine during use. Allow the engine to cool down after use.
6. Never store fuel or other flammable materials near the engine.
7. Secure the equipment on transport vehicles to prevent it from rolling, slipping, and tilting.
8. Industrial applications must follow OSHA requirements.
9. Do not leave the equipment unattended when it is running. Turn off the equipment (and remove safety keys, if available) before leaving the work area.
10. The equipment can produce high noise levels. Prolonged exposure to noise levels above 85 dBA is hazardous to hearing. Wear ear protection when operating or when working nearby while it is operating.
11. Use safety footwear; snug-fitting clothing; protective gloves; eye, hearing, and head protection devices.
12. People with pacemakers should consult their physician(s) before using them. Electromagnetic fields in close proximity to a heart pacemaker could cause pacemaker interference or pacemaker failure. Caution is necessary when near the engine's magneto or recoil starter.
13. Use only accessories that are recommended by the manufacturer. Accessories that may be suitable for one piece of equipment may become hazardous when used on another piece of equipment.
14. Do not operate in explosive atmospheres, such as in the presence of flammable liquids, gases, or dust. Gasoline-powered engines may ignite dust or the fumes.
15. Stay alert, watch what you are doing and use common sense when operating this piece of equipment. Do not use while tired or under the influence of drugs, alcohol, or medication.
16. Do not overreach. Keep proper footing and balance at all times. This enables better control of the equipment in unexpected situations.
17. Use this equipment with both hands only. A chainsaw is intended for two-handed use. Do not operate a chainsaw with one hand! Serious injury to the operator, helpers, bystanders, or any combination of these people may result from one-handed operation.
18. Dress properly. Do not wear loose clothing or jewelry. Keep hair, clothing, and gloves away from moving parts. Loose clothes, jewelry or long hair can be caught in moving parts.
19. Parts, especially exhaust system components, get very hot during use. Stay clear of the hot parts.
20. Do not cover the equipment during operation.
21. Keep the equipment, engine, and surrounding area clean at all times.
22. Do not smoke, or allow sparks, flames, or other sources of ignition around the equipment, especially when refueling.
23. Use the equipment, accessories, etc., in accordance with these instructions and in the manner intended for the particular type of equipment, taking into account the working conditions and the work to be performed. Use of the equipment for operations different from those intended could result in a hazardous situation.

24. Do not operate the equipment with known leaks in the engine's fuel system.
25. When spills of fuel or oil occur, they must be cleaned up immediately. Dispose of fluids and cleaning materials as per any local, state, or federal codes and regulations. Store oil rags in a bottom-ventilated, covered, metal container.
26. Keep hands and feet away from moving parts. Do not reach over or across equipment while operating.
27. Before use, check for misalignment or binding of moving parts, breakage of parts, and any other condition that may affect the equipment's operation. If damaged, have the equipment serviced before use. Many accidents are caused by poorly maintained equipment.
28. Use the correct equipment for the application. Do not modify the equipment and do not use the equipment for a purpose for which it is not intended.
29. Never operate a chainsaw while you are fatigued, ill, upset, under the influence of medication that may make you drowsy, or if you are in the influence of alcohol or drugs.
30. Use safety footwear; snug-fitting clothing; protective gloves; and eye, hearing, and head protection devices. Wear leg protection such as work pants or chaps.
31. Use caution when handling fuel. Mix and pour fuel outdoors where there are no sparks and flames. Slowly remove the fuel cap only after stopping the engine and allowing the chainsaw to cool. Do not smoke while fueling or mixing fuel. Move the chainsaw at least 10 feet (3 m) from the fueling point before starting the engine.
32. Do not allow other persons to be near the chain saw when starting or cutting with the chain saw. Keep bystanders and animals out of the work area.
33. Do not start cutting until you have a clear work area, secure footing, and a planned retreat path from the falling tree.
34. Keep all parts of your body away from the saw chain when the engine is running.
35. Before you start the engine, make sure that the saw chain is not in contact with anything.
36. Do not operate a chainsaw that is damaged, improperly adjusted, or not completely and securely assembled. Be sure that the saw chain stops moving when the throttle control trigger is released.
37. Shut off the engine before setting the chainsaw down.
38. Use extreme caution when cutting small-size brush and saplings because slender material may catch the saw chain and be whipped toward you or pull you off balance.
39. When cutting a limb that is under tension, be alert for spring back so that you will not be struck when the tension in the wood fibers is released.
40. Keep the handles dry, clean, and free of oil or fuel mixture.
41. Operate the chainsaw only in well-ventilated areas.
42. Do not operate a chainsaw in a tree unless you have been specifically trained to do so.
43. All chainsaw services, other than the items listed in the operator's manual(s) maintenance instructions, should be performed by competent chainsaw service personnel. (For example, if improper tools are used to remove the flywheel or if an improper tool is used to hold the flywheel in order to remove the clutch, structural damage to the flywheel could occur and subsequently could cause the flywheel to burst.)
44. Allow the chainsaw to cool before performing maintenance or adjustments.
45. When transporting your chainsaw, use the appropriate guide-bar cover.

14-in, 37.2CC CHAINSAW

46. This machine generates toxic exhaust fumes such as carbon monoxide, and others may be colorless and odorless. To reduce the risk of serious injury/illness from inhalation, never run the machine indoors or in a poorly ventilated location.
47. Do not let familiarity gained from frequent use allow you to become complacent and ignore tool safety principles. A careless action can cause severe injury within a fraction of a second.

SERVICE PRECAUTIONS

1. Before service, maintenance, or cleaning:
 - a. Turn the Engine switch to its "OFF" position.
 - b. Allow the Engine to completely cool.
 - c. Then, remove the spark plug cap from the spark plug.
2. Keep all safety guards in place and in proper working order. Safety guards include the muffler, air cleaner, mechanical guards, and heat shields, among other guards.
3. **DO NOT ALTER OR ADJUST ANY PART OF THE MACHINE OR ITS ENGINE THAT IS SEALED BY THE MANUFACTURER OR DISTRIBUTOR.** Contact PRORUN Customer Service. Only a qualified service technician may adjust parts that may increase or decrease governed Engine speed.
4. Wear ANSI-approved safety goggles, heavy-duty work gloves, and dust mask/respirator during service.
5. Maintain labels and nameplates on the machine. These carry important information. If unreadable or missing, contact an authorized dealer for a replacement.
6. Have the machine serviced by a PRORUN Customer Service qualified repair person using only identical replacement parts. This will ensure that the safety of the machine is maintained. Do not attempt any service or maintenance procedures not explained in this manual or any procedures that you are uncertain about your ability to perform safely or correctly.
7. Store the machine out of the reach of children.
8. Follow schedule for the Engine's and the machine's maintenance.

REFUELING:

1. Do not refill the fuel tank while the Engine is running or hot.
2. Do not smoke, or allow sparks, flames, or other sources of ignition around the machine, especially when refueling.

⚠ WARNING! TO PREVENT FUEL LEAKAGE AND FIRE HAZARD DO NOT FILL FUEL ABOVE THE BOTTOM OF THE THREADS.

3. Do not fill the fuel tank to the top. Leave a little room for the fuel to expand as needed, at least 1 inch from the top of the neck.
4. Refuel in a well-ventilated area only.
5. Wipe up any spilled fuel and allow excess to evaporate before starting the Engine. To prevent FIRE, do not start the Engine while the smell of fuel hangs in the air.

4. GENERAL WARNINGS

CHAINSAW SAFETY WARNINGS

1. **Keep all parts of the body away from the saw chain when the chainsaw is operating. Before you start the chainsaw, make sure the saw chain is not contacting anything.** A moment of inattention while operating chainsaws may cause entanglement of your clothing or body with the saw chain.
2. **Always hold the chainsaw with your right hand on the rear handle and your left hand on the front handle.** Holding the chainsaw with a reversed hand configuration increases the risk of personal injury and should never be done.
3. **Hold the chainsaw by the insulated gripping surfaces only, because the saw chain may contact hidden wiring.** Saw chains contacting a “live” wire may make exposed metal parts of the power tool “live” and could give the operator an electric shock.
4. **Wear safety glasses and hearing protection. Further protective equipment for the head, hands, legs, and feet is recommended.** Adequate protective clothing will reduce personal injury by flying debris or accidental contact with the saw chain.
5. **Do not operate a chainsaw in a tree.** The operation of a chainsaw while up in a tree may result in personal injury.
6. **Do not allow other people to be near the chainsaw when starting or cutting with the chainsaw.** Keep bystanders and animals out of the work area. Do not start cutting until you have a clear work area, secure footing, and a planned retreat path from the falling tree.
7. **When cutting a limb that is under tension be alert for spring back.** When the tension in the wood fibers is released the spring loaded limb may strike the operator and/or throw the chainsaw out of control.
8. **Use extreme caution when cutting brush and saplings.** The slender material may catch the saw chain and be whipped toward you or pull you off balance.
9. **Carry the chainsaw by the front handle with the engine stopped, the guide bar and saw chain to the rear, and the muffler away from your body. When transporting or storing the chainsaw always fit the guide bar cover over the saw’s bar and chain.** Proper handling of the chainsaw will reduce the likelihood of accidental contact with the moving saw chain.
10. **Follow instructions for lubricating, chain tensioning and changing accessories.** Improperly tensioned or lubricated chain may either break or increase the chance for kickback.
11. **Keep handles dry, clean, and free from oil and grease.** Greasy, oily handles are slippery causing loss of control.
12. **Cut wood only. Do not use chainsaw for purposes not intended. FOR EXAMPLE: do not use chainsaw for cutting plastic, masonry, or non-wood building materials.** Use of the chainsaw for operations different than intended could result in a hazardous situation.

14-in, 37.2CC CHAINSAW

⚠ WARNING!  **KICKBACK MAY OCCUR WHEN THE NOSE OR TIP OF THE GUIDE BAR TOUCHES AN OBJECT, OR WHEN THE WOOD CLOSES IN AND PINCHES THE SAW CHAIN IN THE CUT.**

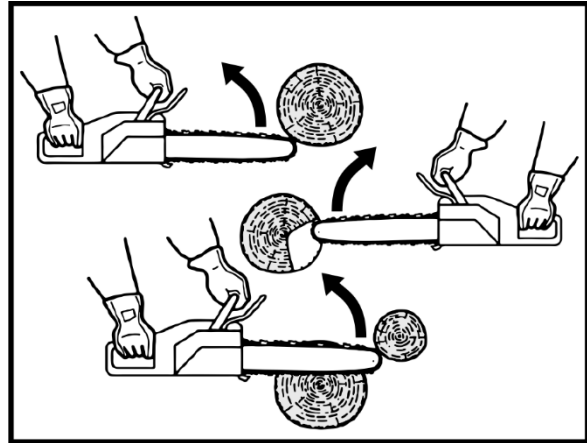

13. **Tip contact in some cases may cause a lightning-fast reverse reaction, kicking the guide bar up and back toward the operator.** Pinching the saw chain along the top of the guide bar may push the guide bar rapidly back toward the operator. Either of these reactions may cause you to lose control of the saw, which could result in serious personal injury. Do not rely exclusively upon the safety devices built into your saw.
- AS A CHAINSAW USER, YOU SHOULD TAKE SEVERAL STEPS TO KEEP YOUR CUTTING JOBS FREE FROM ACCIDENT OR INJURY.**
- With a basic understanding of kickbacks, you can reduce or eliminate the element of surprise. Sudden surprise contributes to accidents.
 - Keep a good firm grip on the saw with both hands, the right hand on the rear handle and the left hand on the front handle, when the engine is running. Use a firm grip with thumbs and fingers encircling the chainsaw handles. A firm grip will help reduce kickbacks and maintain control of the saw. Don't let go.
 - Make sure that the area in which you are cutting is free from obstructions. Do not let the nose of the guide bar contact a log, branch, or any other obstruction that could be hit while you are operating the saw.
 - Cut at high engine speeds.
 - Do not overreach or cut above shoulder height.
 - Follow the manufacturer's sharpening and maintenance instructions for the saw chain.
 - Only use replacement bars and chains specified by the manufacturer or the equivalent. Decreasing the depth gauge height can lead to increased kickbacks.
14. **Maintain labels and nameplates on the tool.** These carry important safety information. If unreadable or missing, contact the manufacturer for a replacement.
15. **Do not leave the tool unattended when it is running.** Turn off the tool before leaving the work area.
16. **This product is not a toy.** Keep it out of reach of children.
17. **People with pacemakers should consult their physician(s) before using them.** Electromagnetic fields in close proximity to heart pacemakers could cause pacemaker interference or pacemaker failure.
18. **The warnings, precautions, and instructions discussed in this instruction manual cannot cover all possible conditions and situations that may occur.** It must be understood by the operator that common sense and caution are factors which cannot be built into this product but must be supplied by the operator.







SAVE THESE INSTRUCTIONS

This manual contains important instructions that should be followed during setup, operation, and maintenance of the chainsaw.

5. SYMBOLS

SYMBOL	SIGNIFICATION
	WARNING: Read and follow all safety precautions in the operator's manual(s). Failure to follow instructions could result in serious personal injury.
	WARNING: Risk of Loss of Control. Do not operate the chainsaw with only one hand.
	WARNING: Risk of Loss of Control. Always use two hands when operating the chainsaw.
	WARNING: Saw Chain Orientation. Cutters must face in direction of the rotation.
	WARNING: Risk of Kickback. Contact of the guide bar tip with any object must be avoided.
	Read the manual before set-up and / or use of the chainsaw.
	Appropriate ear, eye, and head protection must be worn.
	Always wear safety and anti-vibration (AV) gloves when operating the chainsaw.
	Always wear safety and slip-resistant boots when operating the chainsaw.
	Indicates the direction that the chain brake is released (WHITE ARROW) and activated (BLACK ARROW)
	Indicates the port to refuel the "MIXED GASOLINE".
	Indicates the operation of the engine switch. Flip the switch to the "O" position to stop the engine immediately. "O" and "I" are shown on switch button.

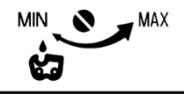
14-in, 37.2CC CHAINSAW

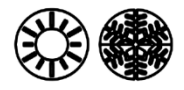
SYMBOL	SIGNIFICATION
	Indicates the operation of the engine switch. Flip the switch to the “O” position to stop the engine immediately.
	Indicates the port to refill the saw chain oil.
	Indicates the adjustment of the oil flow. Turn the screw with a screwdriver counter-clockwise and the saw chain oil flows more. Turn the screw clockwise and the saw chain oil flows less.
	Indicates the operation of the choke knob. Pull the choke knob Out closes the choke. Push the choke knob In opens the choke.
H L T	The screw under the “H” stamp indicates The High-speed mixture adjustment screw. The screw under the “L” stamp indicates The Low-speed mixture adjustment screw. The screw under the “T” stamp indicates The Idle-speed mixture adjustment screw.
	Indicates normal mode and anti-freeze mode for carburetor anti-freeze mechanism

6. SET UP

 **READ THE ENTIRE IMPORTANT SAFETY INFORMATION SECTION AT THE BEGINNING OF THIS MANUAL INCLUDING ALL TEXT UNDER SUBHEADINGS THEREIN BEFORE SETUP OR USE OF THIS PRODUCT.**

 WARNING! **TO PREVENT SERIOUS INJURY:**
Operate only with proper spark arrestor installed.

 WARNING!   **OPERATION OF THIS EQUIPMENT MAY CREATE SPARKS THAT CAN START FIRES AROUND DRY VEGETATION. A SPARK ARRESTOR MAY BE REQUIRED.**

The operator should contact local fire agencies for laws or regulations relating to fire prevention requirements.

 CAUTION! **TO PREVENT SERIOUS INJURY FROM ACCIDENTAL STARTING:**
Make sure that the Engine is switched OFF, wait for the Engine to cool, and unplug the spark plug wire before performing any procedure in this section.

NOTE AT HIGH ALTITUDES, THE ENGINE'S CARBURETOR, GOVERNOR (IF SO EQUIPPED), AND ANY OTHER PARTS THAT CONTROL THE FUEL-AIR RATIO WILL NEED TO BE ADJUSTED BY A QUALIFIED MECHANIC TO ALLOW EFFICIENT HIGH-ALTITUDE USE AND TO PREVENT DAMAGE TO THE ENGINE AND ANY OTHER DEVICES USED WITH THIS PRODUCT.

COMPONENTS AND CONTROLS

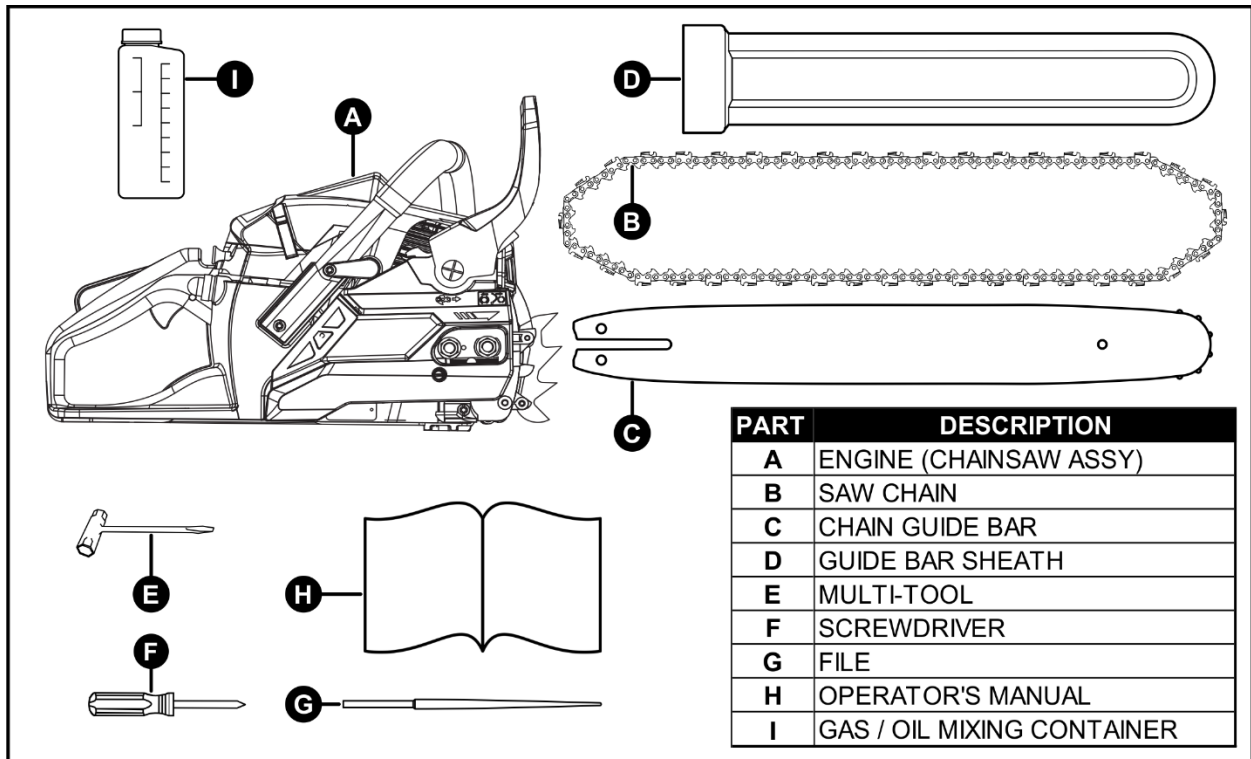

14-in, 37.2CC CHAINSAW

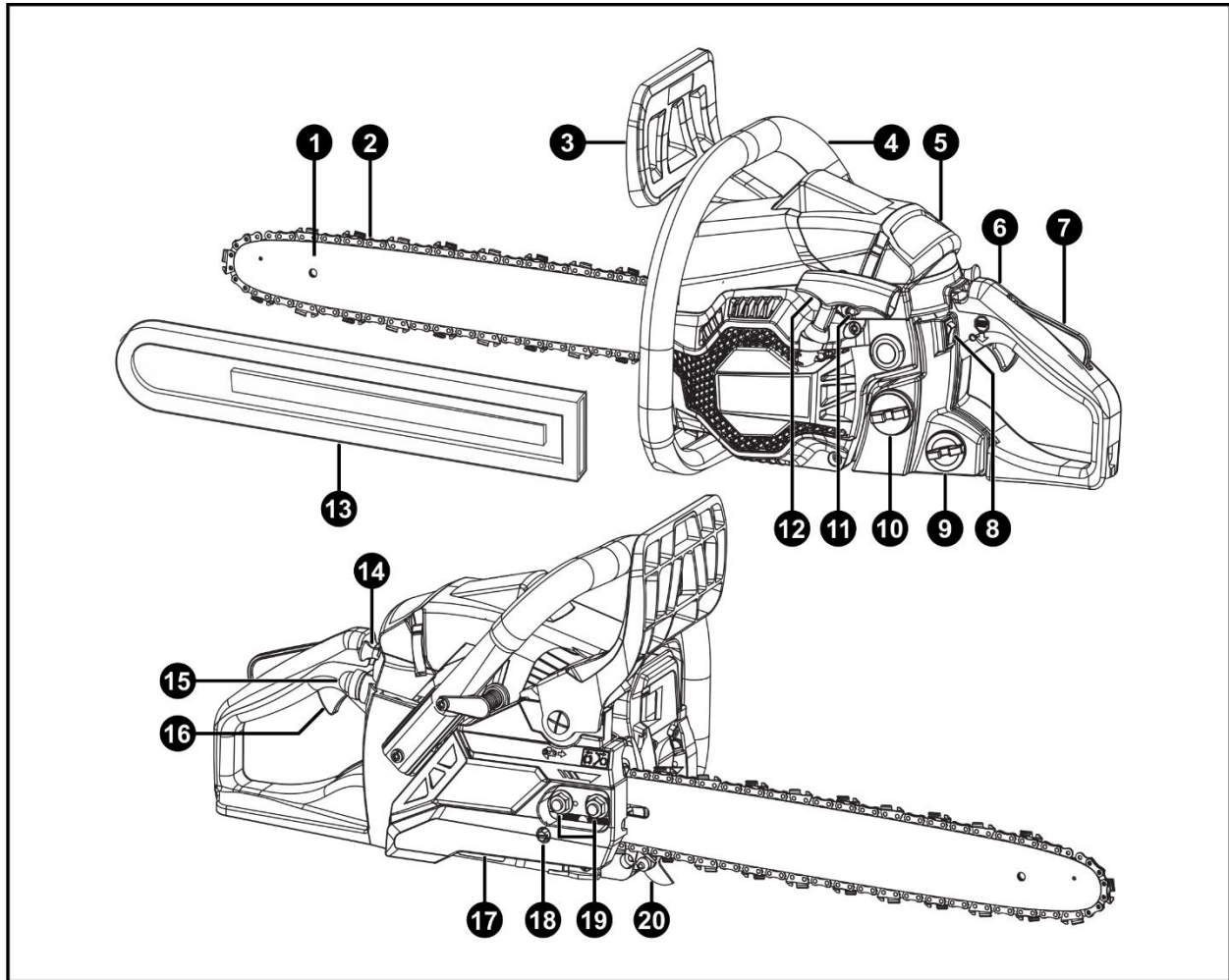

- | | |
|-----------------------------------|-------------------------------|
| 1. Chain Guide Bar | 11. Idle Adjustment Screw |
| 2. Saw Chain | 12. Starter Grip |
| 3. Hand Guard / Chain Brake Lever | 13. Bar and Chain Guard Cover |
| 4. Wraparound Handle | 14. Choke Knob |
| 5. Air Filter Cover | 15. Primmer Bulb |
| 6. Rear Handle | 16. Power Trigger |
| 7. Tigger Lockout Switch | 17. Chain Drive Cover |
| 8. Engine Switch | 18. Chain Tightening Screw |
| 9. Chain Oil Cap | 19. Chain Cover Nuts |
| 10. Fuel Tank Cap | 20. Bucking Spikes |

GUIDE BAR AND SAW CHAIN INSTALLATION AND ADJUSTMENT

⚠ WARNING! TO PREVENT SERIOUS INJURY FROM ACCIDENTAL OPERATION: Make sure that the Engine is switched OFF, wait for the Engine to cool, and unplug the spark plug wire before performing any procedure in this section.

NOTE NEW SAW CHAINS OFTEN NEED TO BE TENSIONED SEVERAL TIMES DURING FIRST USE. CHECK A NEW SAW CHAIN'S TENSION OFTEN WHEN FIRST USING.

NOTE THE GUIDE BAR AND SAW CHAIN NEED TO BE REMOVED WHEN CERTAIN MAINTENANCE PROCEDURES ARE PERFORMED SUCH AS WHEN ROTATING THE GUIDE BAR AND WHEN REPLACING WORN BARS AND SAWS.

When installing the Guide bar and Saw Chain for the first time, or replacing a worn bar and chain, follow the directions in the sections for INSTALLING THE GUIDE BAR AND SAW CHAIN, and CHECKING AND ADJUSTING SAW CHAIN TENSION.

REMOVING THE CHAIN DRIVE COVER

1. Pull the Hand Guard / Brake Lever (3) back toward the rear to make sure the chain brake is not on.

⚠ IMPORTANT! IF THE HAND GUARD / BRAKE LEVER IS NOT DISENGAGED PRIOR TO REMOVING THE CHAIN DRIVE COVER, IT WILL BE DIFFICULT TO REINSTALL THE COVER DUE TO THE BRAKE STRAP BEING RETRACTED.

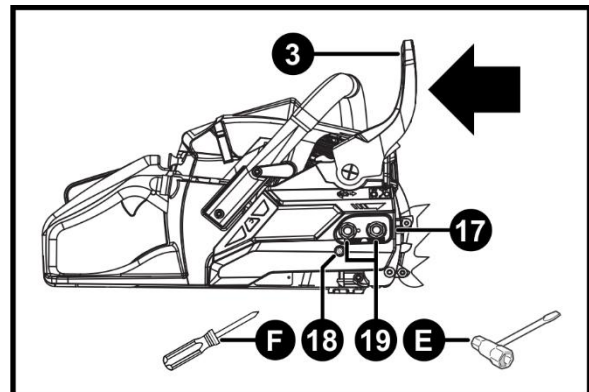

2. Use the Multi-Tool (E) to loosen and remove the Drive Cover Nuts (17).
3. Remove the Chain Drive Cover (15) from the Saw.

IF THIS IS THE FIRST TIME THE BAR AND CHAIN HAVE BEEN INSTALLED ON TO THE CHAINSAW, SKIP STEPS 4-6 AND PROCEED TO STEP 7.

4. Loosen the Bar and Chain assemble by turning the Chain Tightening Screw (16) counterclockwise.
5. Pull the Saw Chain towards the handles and over the Drive Sprocket. Remove the Guide Bar and Saw Chain from the Guide Bar Bolts.
6. Remove the Saw Chain from the Guide Bar

14-in, 37.2CC CHAINSAW

ASSEMBLING THE SAW CHAIN ONTO THE GUIDE BAR

7. Set the Saw Chain on a flat surface and straighten out any kinks.
8. Place the Saw Chain (2) over the Chain Guide Bar (1) and into the Guide Bar groove (A1) while creating a loop of the Saw Chain at the back end of the Guide Bar.

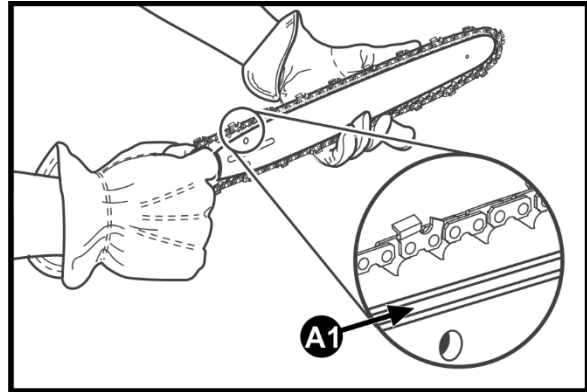

▲ IMPORTANT! MAKE SURE THE CUTTER POINTS ARE IN THE CORRECT DIRECTION OF ROTATION. SEE ILLUSTRATION LOCATED ON THE CHAINSAW.

- Direction of saw (A2)
- The Cutters links (A3) of the saw chain must face away from the chainsaw along the top edge of the Guide Bar.
- The Drive links (A4) fit into the groove around the guide bar.
- Depth Gauge links (A5) on a chainsaw control the amount of wood removed by each cutting tooth during a cut

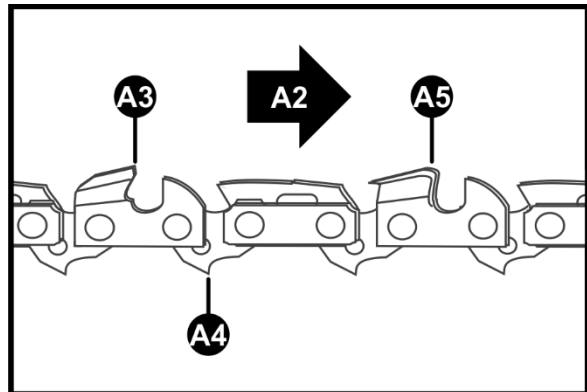

INSTALLING THE GUIDE BAR AND SAW CHAIN ASSEMBLY ONTO THE CHAINSAW

9. Hold the Saw Chain and Guide Bar together in position over the unit.
10. Loop the Saw Chain around the Drive Sprocket (A6) and install the Guide Bar onto the Guide Bar Post.
11. Align and place the slotted end of the Chain Guide Bar over the Guide Bar Bolts (A7) and place the Saw Chain over the Drive Sprocket.
12. Make sure the Guide Bar is flush against the mounting surface and make sure the Drive links on the Saw Chain are in the grooves on the Drive Sprocket.

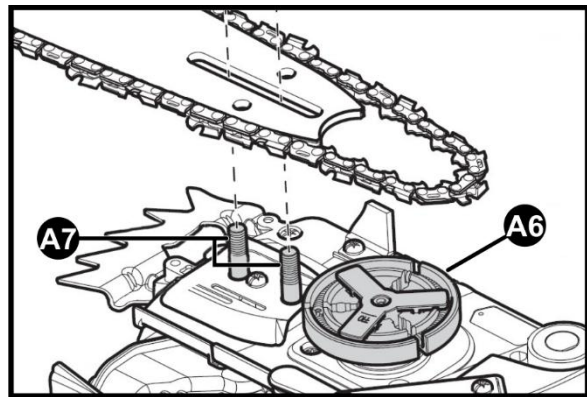

NOTE CHECK AGAIN THAT THE CUTTER LINKS (A3) ARE ALIGNED PROPERLY, AND THE DRIVE LINKS ARE SEATED COMPLETELY IN THE SLOT OF THE GUIDE BAR. THE CUTTERS OF THE SAW CHAIN MUST FACE AWAY FROM THE CHAINSAW ALONG THE TOP EDGE OF THE GUIDE BAR

INSTALLING THE CHAIN DRIVE COVER.

13. Replace the Chain Drive Cover making sure that:
14. The Chain Tensioning Pin (A8) is in the Pin Hole (A9) on the Guide Bar.
15. The Chain Drive Cover Pin (A10) is in the Pin Hole (A11) on the Chainsaw
16. Replace the Drive Cover Nuts (17) and tighten so that the Chain Drive Cover is snug, but do not tighten the bar retaining nuts completely

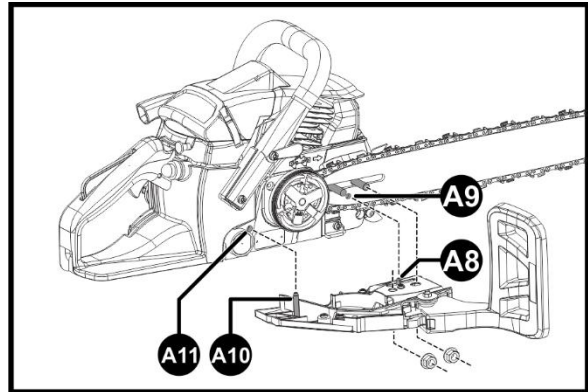

NOTE MAKE SURE THE SAW CHAIN IS STILL IN THE GUIDE BAR GROOVE ADJUST THE CHAIN TENSION.

17. Adjust the tension of the Saw Chain utilizing the following steps listed below.

CHECKING SAW CHAIN TENSION

Check the saw chain tension before and during all operations. The saw chain expands as it heats up during use. Adjust the chain tension whenever the Drive links (A4) on the saw chain hang out from the Bar Guide groove (A).

1. Before using, check the Saw Chain tension.
2. Make sure that the Chain Break (3) is disengaged.
3. While wearing heavy-duty gloves, use your index finger and thumb to carefully grab the Saw Chain in the middle section under the Chain Guide Bar.
4. Pull the Saw Chain away from the Guide Bar.
5. The Saw Chain should snap back against the Guide Bar. The Saw Chain should fit snugly in the groove of the Chain Guide Bar.

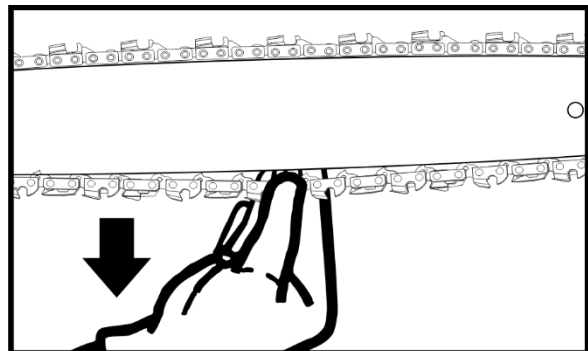

14-in, 37.2CC CHAINSAW

NOTE IT IS NORMAL FOR A NEW SAW CHAIN TO STRETCH AND REQUIRE READJUSTMENT IN AS LITTLE AS FIVE CUTS.

This is typical during the break-in period, The period between future adjustments will lengthen quickly over time.

6. You should still be able to slide the chain along the Chain Guide Bar by hand.

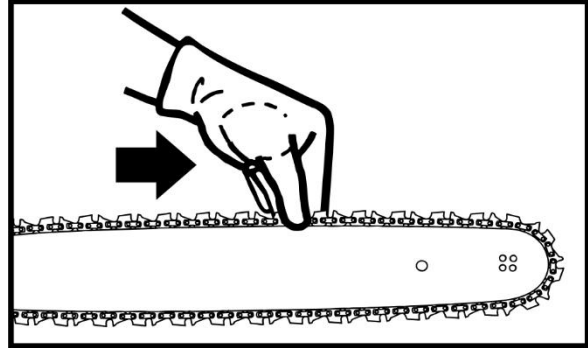

7. There should be no sagging between the Guide Bar and Saw Chain on the underside of the Guide Bar.

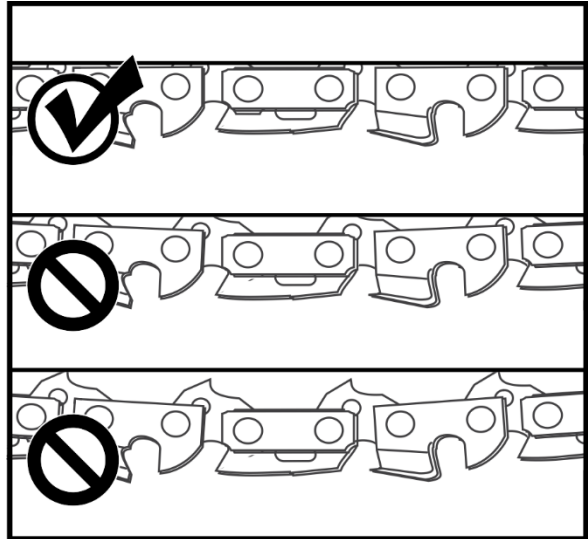

ADJUSTING SAW CHAIN TENSION

NOTE IT IS NOT NECESSARY TO REMOVE THE DRIVE COVER TO ADJUST CHAIN TENSION.

1. Slightly loosen the Drive Cover Nuts on the Drive Cover. Do not remove the nuts or cover.

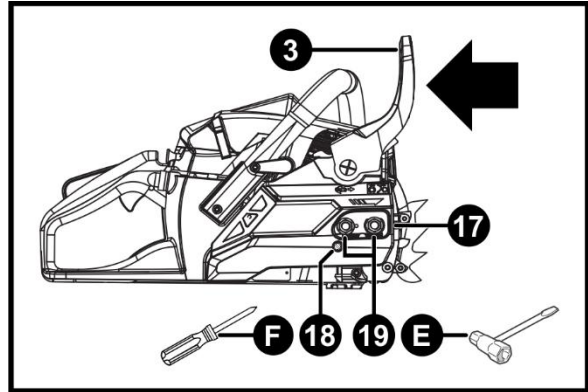

2. Turn the Chain Tension Screw clockwise to increase chain tension and counterclockwise to decrease tension.

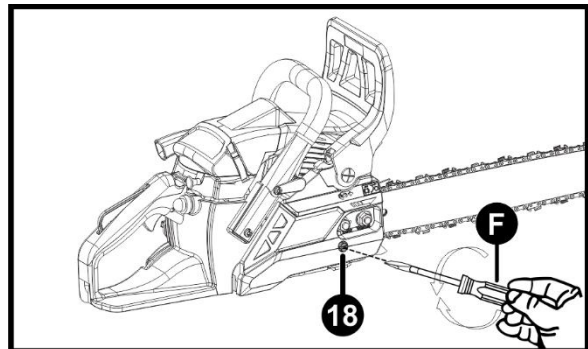

3. Tighten the Drive Cover Nuts on the Drive Cover while holding the Chain Guide Bar up.

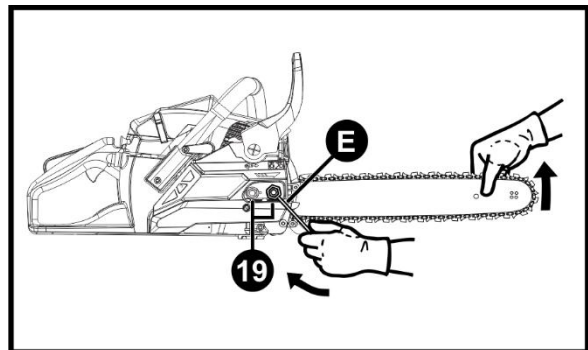

4. Check the Saw Chain tension again following steps 1 through 7 under CHECKING SAW CHAIN TENSION listed above. If needed, repeat the adjusting steps to achieve the correct tension.

7. CONTROLS AND OPERATIONS



READ THE ENTIRE IMPORTANT SAFETY INFORMATION SECTION AT THE BEGINNING OF THIS MANUAL INCLUDING ALL TEXT UNDER SUBHEADINGS THEREIN BEFORE SETUP OR USE OF THIS PRODUCT.

▲ IMPORTANT!

CHECK ENGINE, FUEL, CHAION OIL, AND SAW CHAIN TENSION
Inspect the engine and equipment looking for damaged, loose, and missing parts before setting up and starting. If any problems are found, do not use the equipment until fixed properly.

CHECKING AND FILLING FUEL

▲ WARNING!



TO PREVENT SERIOUS INJURY FROM FIRE:

Fill the fuel tank in a well-ventilated area away from ignition sources. If the engine is hot from use, shut the engine off and wait for it to cool before adding fuel. Do not smoke.

1. Clean the Fuel Tank Cap and the area around it.
2. Unscrew and remove the Fuel Tank Cap.

NOTE

DO NOT USE GASOLINE CONTAINING MORE THAN 10% ETHANOL (E10). DO NOT USE E85 ETHANOL. ADD FUEL STABILIZER TO THE GASOLINE OR THE WARRANTY IS VOID.

NOTE

DO NOT USE GASOLINE THAT HAS BEEN STORED IN A METAL FUEL CONTAINER OR A DIRTY FUEL CONTAINER. IT CAN CAUSE PARTICLES TO ENTER THE CARBURETOR, AFFECTING ENGINE PERFORMANCE AND/OR CAUSING DAMAGE.

▲ IMPORTANT!

YOUR WARRANTY IS VOID IF THE ENGINE'S FUEL TANK IS NOT FILLED WITH THE PROPER MIXTURE (50:1) OF UNLEADED GASOLINE AND 2-CYCLE OIL BEFORE EACH USE.

2-Stroke oil (conventional, mineral-based, synthetic) must meet either JASO M345 FD or ISO-L-EGD requirements for air-cooled engines. Before each use, check the fuel level. Do not run the engine with an improper unleaded gasoline / 2-cycle oil mixture. Running the engine with an improper mixture WILL permanently damage the engine.

3. To obtain the proper gasoline and 2-cycle oil mixture, mix 50:1 gas-to-oil ratio: 2.56 oz oil per 1 gallon of gasoline (20 ml oil per 1 liter gasoline) into an approved container. Then gently agitate the container to thoroughly mix the gasoline / 2-cycle oil.

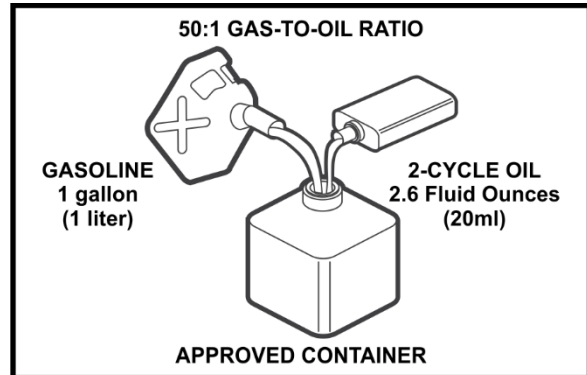

4. If needed, fill the Fuel Tank to about 1 inch under the fill neck of the Fuel Tank with the pre-mixed unleaded gasoline / 2-cycle oil mixture.
5. Then close the fuel tank with the fuel tank cap.
6. Wipe up any spilled fuel and allow excess to evaporate before starting the engine. To prevent FIRE, do not start the engine while the smell of fuel hangs in the air.
7. Use caution when handling fuel. Move the chainsaw at least 10 feet (3 meters) from the fueling point before starting the engine.

CHECKING CUTTING OIL SUPPLY

⚠ IMPORTANT! NEVER USE THE MACHINE WITHOUT LUBRICATION! ALWAYS CHECK CHAIN LUBRICATION AND THE OIL LEVEL IN THE TANK BEFORE STARTING WORK.

For a chainsaw to cut safely and effectively, its chain must have the proper lubrication. If the chain is too dry it can rob the engine of power due to increased friction. If the chain is too dry it runs the risk of breaking and causing personal injury.

1. After starting the engine run the chainsaw at medium speed and see if the chain oil is scattered off as shown in Figure A.

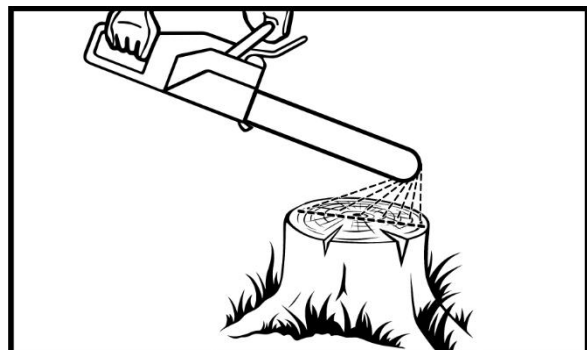

14-in, 37.2CC CHAINSAW

2. The oil adjustment screw is located under the chainsaw as shown.
3. With a narrow flat-tipped screwdriver, adjust the flow of lubrication according to your work conditions.
 - a. To increase the oil flow, turn the automatic oiler adjustment screw counterclockwise
 - b. To decrease the oil flow, turn the automatic oiler adjustment screw clockwise.

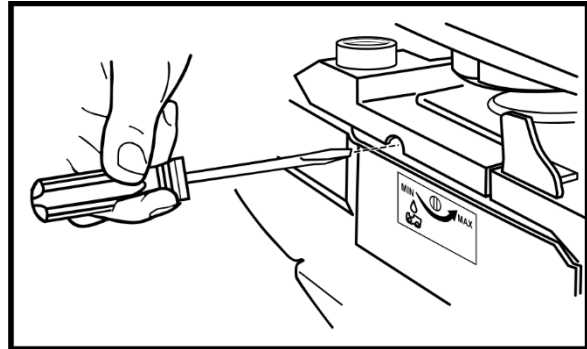

STARTING THE ENGINE



BEFORE STARTING THE ENGINE:

- a. **Inspect the equipment and engine.**
- b. **Fill the engine with the proper amount and type of unleaded gasoline and 2-cycle oil mixture.**
- c. **Fill the oil tank with the proper amount and type of bar and chain oil.**

MANUAL START

A "Cold Start" is when the engine is no longer hot to the touch, typically at least 30 minutes after its last run.

1. To start a cold engine or first start of the day, ensure the Guide Bar and Saw Chain are not touching or near any object as Chain will spin during startup. Push the Hand Guard / Chain Brake Lever (3) forward to engage the Chain Brake.

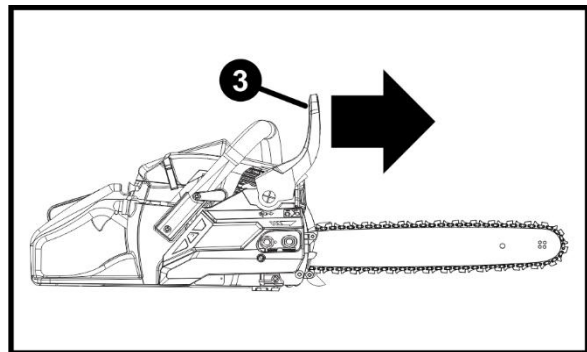

2. Rotate the Engine Switch (8) to the "I" position.

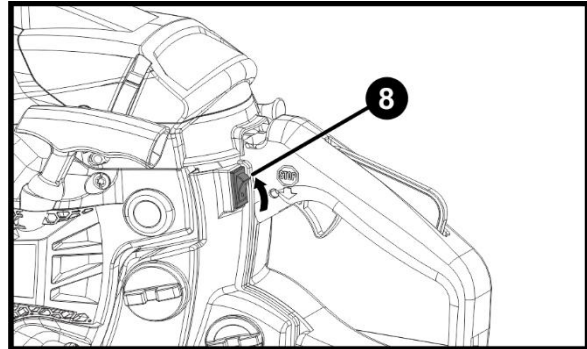

3. Press the Prime Bulb (15) up to 10 times until the Bulb begins to fill with fuel.

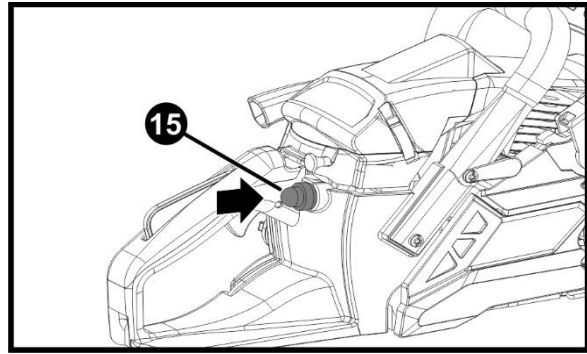

4. Pull out the Choke Knob (14) to the START (closed) position.

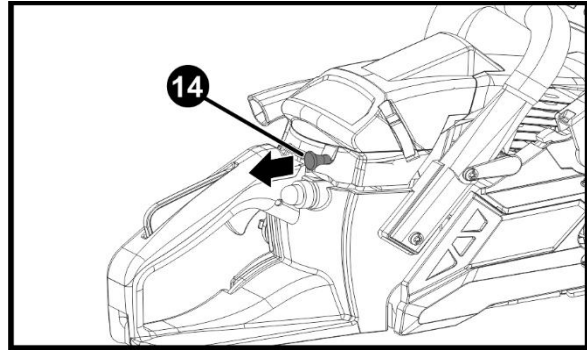

5. Hold the Chainsaw securely on the ground. Strongly grip the Starter Grip (12) of the Engine and pull it firmly and evenly until the engine attempts to start and stalls.

NOTE DO NOT LET THE STARTER HANDLE SNAP BACK AGAINST THE ENGINE. HOLD IT AS IT RECOILS SO IT DOESN'T HIT THE ENGINE.

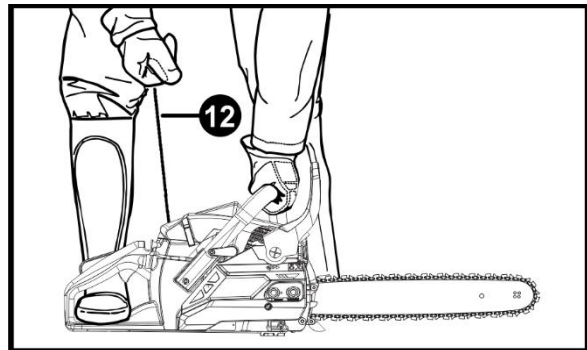

14-in, 37.2CC CHAINSAW

6. Press the Choke Knob (14) back to the RUN (open) position, this will partially engage the Throttle to assist starting.

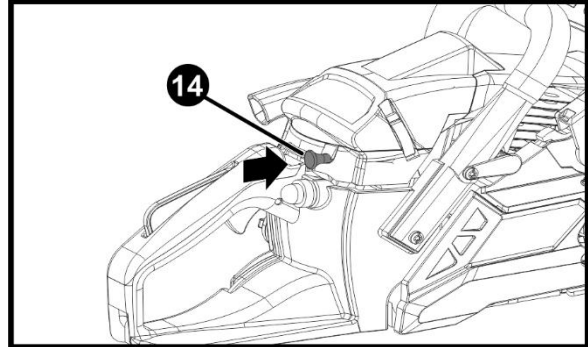

7. Repeatedly pull the Starter Grip (12) firmly and evenly until the engine starts. Immediately disengage the Chain Brake by pulling back on the Hand Guard / Chain Brake Lever (3).

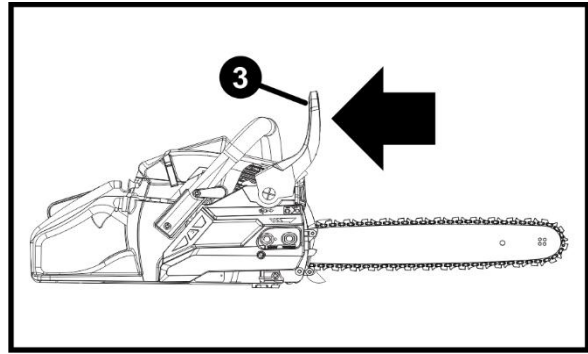

⚠ CAUTION! THE SAW CHAIN WILL IMMEDIATELY START SPINNING WITH THE ENGINE RUNNING AT PARTIAL THROTTLE.

8. Allow the Engine to run at partial throttle for five seconds.
 - Quickly squeeze and then release the Power Trigger to disengage the Throttle assist and allow the Engine to idle.
 - Allow the Engine to warm up at idle for 60 seconds after each Start-up so that the Engine can stabilize before use.

TO RESTART A WARM ENGINE

FOLLOW THE STARTING INSTRUCTIONS FOUND ABOVE WITH THE FOLLOWING EXCEPTION:

- Omit Step 5 and proceed to Step 6.

STOPPING THE ENGINE

1. To stop the Engine in an emergency, release the Power Trigger (16) and press the Stop Engine Switch (8).
2. Under normal conditions, use the following procedure:
 - a. Release the Power Trigger (16).
 - b. Let the engine idle for 3 to 5 minutes.
 - c. Press the Stop Engine Switch (8).

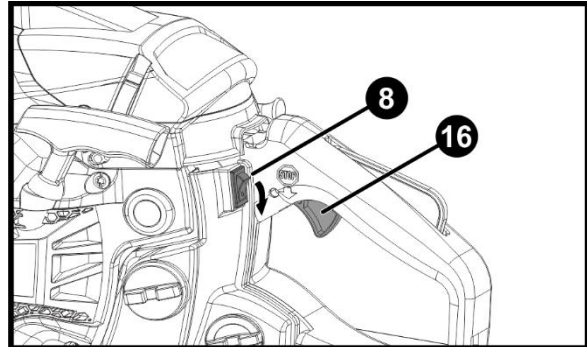

⚠ CAUTION! WORKPIECE AND WORK AREA SET UP

- Designate a work area that is clean and well lit. The work area must not allow access by children or pets to prevent distraction and injury.
- There must not be objects, such as utility lines, nearby that will present a hazard while working.
- A first-time user should, as a minimum practice, cut logs on a sawhorse or cradle before cutting down trees.

GENERAL OPERATING INSTRUCTIONS

1. Before the first use and before each use, thereafter, remove the Chain Oil Tank Cap (9).
 - Inspect the Cap Gasket for damage.
 - Fill the Oil Tank to just below the fill plug with oil (not included).
 - Refer to the PRODUCT SPECIFICATIONS chart for oil type.
 - Then close the Oil Tank with the Chain Oil Tank Cap. Oil is automatically applied to the Saw Chain during operation.
2. Start the Engine as detailed in section STARTING THE ENGINE. If necessary, adjust Engine idle speed so Saw Chain does not rotate at idle.
 - To adjust, turn the Idle Adjusting Screw (11) counterclockwise to lower idle speed until Chain does not turn.

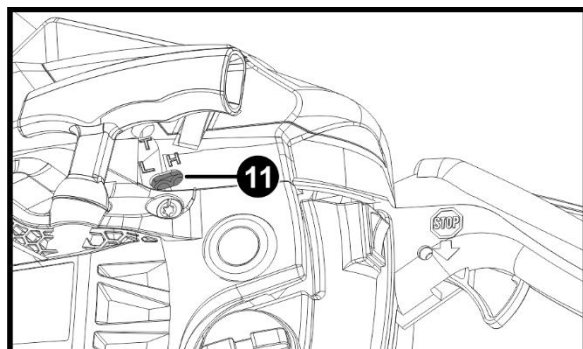
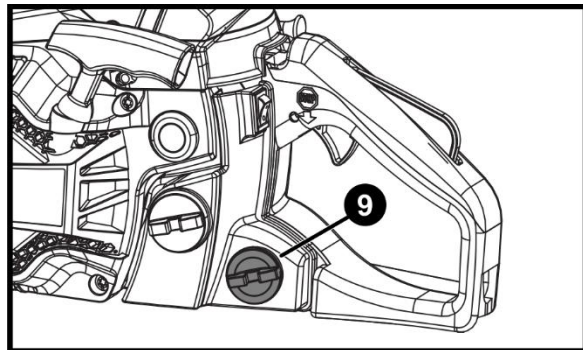

14-in, 37.2CC CHAINSAW

- Place the Hand Guard / Chain Brake Lever (3) in normal operating (disengaged) position by pulling the Hand Guard back toward the Wraparound Handle.

NOTE THE CHAINSAW WILL NOT OPERATE UNLESS THE HAND GUARD / CHAIN BRAKE LEVER IS IN THE DISENGAGED POSITION.

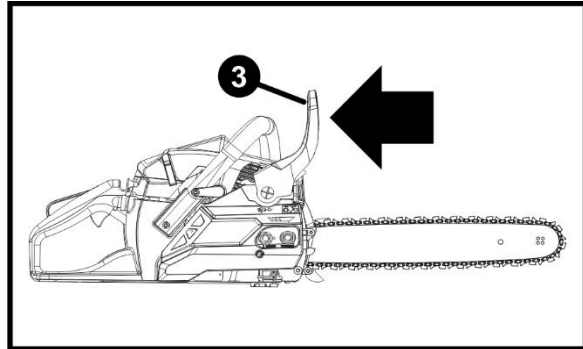

- Grasp the Handles with both hands. Always grip the handle with the thumb and fingers encircling the handle.

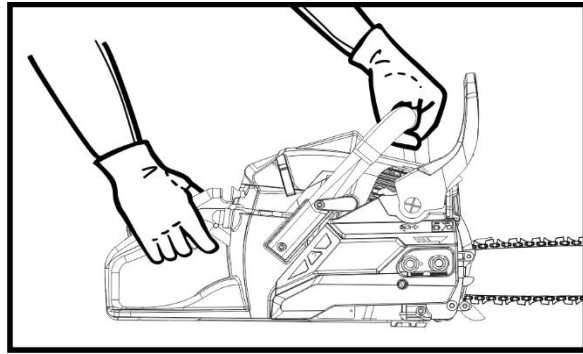

- Stand in front of the wood to be cut with your feet firmly in place.
- Grasp the Rear Handle to activate the Power Trigger Lockout Switch, then squeeze and hold the Power Trigger. Releasing the Power Trigger will return the Engine to idling speed.

NOTE THE POWER TRIGGER CANNOT BE ACTIVATED UNLESS THE POWER TRIGGER LOCKOUT SWITCH IS DEPRESSED.

⚠ DANGER! TO PREVENT SERIOUS INJURY AND DEATH FROM KICKBACK: DO NOT TOUCH THE GUIDE BAR NOSE TO THE WOOD.

- When the Chainsaw reaches full speed, begin cutting with a light, downward pressure against the bottom mid-section of the Saw Chain. Allow the Saw Chain to cut at its own rate. Applying too much pressure can damage the tool.

⚠ DANGER! TO PREVENT SERIOUS INJURY AND DEATH FROM KICKBACK: WHEN CUTTING LOOSE, ROUND WOOD STOCK, PLACE THE WOOD STOCK ON A SAWHORSE, IN A CRADLE, OR USE A TIMBER JACK (ALL SOLD SEPARATELY) TO AVOID GRABBING AND THROW BACK.

- When cutting is complete release the Power Trigger, allow the Engine to idle 3 to 5 minutes, then press the Stop Engine Switch. To prevent accidents, place the Hand Guard / Chain Brake Lever forward in its engaged position after use.

9. When the Saw has cooled completely, clean thoroughly and cover the Chain Guide Bar with the Chain Guide Bar Sheath. Store the tool indoors out of children's reach. See Long-Term Storage on page 29 for complete storage instructions.

CARBURETOR ANTI-FREEZE MECHANISM

OPERATING THE CHAINSAW IN TEMPERATURES OF 32° - 41° F (0° - 5° C) DURING TIMES OF HIGH HUMIDITY MAY RESULT IN ICE FORMING WITHIN THE CARBURETOR, AND THIS IN TURN MAY CAUSE THE OUTPUT POWER OF THE ENGINE TO BE REDUCED OR FOR THE ENGINE TO FAIL TO OPERATE SMOOTHLY.

This product has been designed with a ventilation hatch on the right side of the surface of the cylinder cover to allow warm air to be supplied to the engine and to thereby prevent icing from occurring.

- Under normal circumstances the product should be used in the normal operating mode, i.e., in the mode which it is set at the time of shipment.
- However when the possibility exists that icing may occur, the unit should be set to operate in the anti-freeze mode before use.
- Continuing to use the product in the anti-freeze mode even when temperatures have risen and returned to normal, may result in the engine failing to start properly or in the engine failing to operate at its normal speed, and for this reason you should always be sure to return the unit to the normal operating mode if there is no danger of icing occurring.

TO SWITCH FROM NORMAL MODE TO LOW TEMPERATURE ANTIFREEZE MODE PROCEED AS FOLLOWS:

1. Flip the Engine Switch to turn OFF the engine.
2. Remove the Air Filter Cover, remove the Air Filter, and then remove the Choke Knob from the cylinder cover.
3. Loosen the screws holding the Cylinder Cover (X) in place (the three screws on the inside and the one screw on the outside of the Cylinder Cover) and then remove the cylinder cover.
4. Press with your finger down on the Icing Cap (Y) located on the right-hand side of the Cylinder
5. Cover to remove the Icing Cap out from its slot.
6. Adjust the icing cap so that the "SNOW" (Z) mark faces upwards and then return it to its original
7. position in the Cylinder Cover.
8. Fix the Cylinder Cover back into its original position and then fix all other parts back into their original and proper positions.

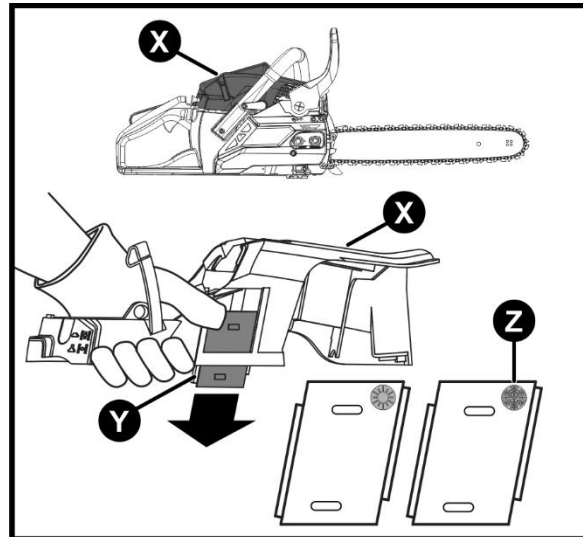

INSTRUCTIONS CONCERNING THE PROPER TECHNIQUES FOR BASIC FEELING, LIMBING, AND CROSS-CUTTING

WHEN BUCKING AND FELLING OPERATIONS ARE BEING PERFORMED BY TWO OR MORE PERSONS AT THE SAME TIME, THE FELLING OPERATIONS SHOULD BE SEPARATED FROM THE BUCKING OPERATION BY A DISTANCE OF AT LEAST TWICE THE HEIGHT OF THE TREE BEING FELLED.

- Trees should not be felled in a manner that would endanger any person, strike any utility line, or cause any property damage.
- If the tree does make contact with any utility line, the company should be notified immediately.

⚠ CAUTION! THE CHAINSAW OPERATOR SHOULD KEEP ON THE UPHILL SIDE OF THE TERRAIN AS THE TREE IS LIKELY TO ROLL OR SLIDE DOWNHILL AFTER IT IS FELLED.

AN ESCAPE PATH SHOULD BE PLANNED AND CLEARED AS NECESSARY BEFORE CUTS ARE STARTED.

- The escape path should extend back and diagonally to the rear of the expected line of fall as illustrated.
- Before felling is started, consider the natural lean of the tree, the location of larger branches and the wind direction to judge which way the tree will fall.
- Remove dirt, stones, loose bark, nails, staples, and wire from the tree.

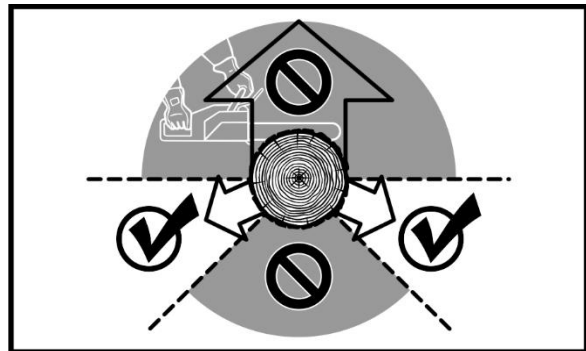

THE BUCKING SPIKES (18) MUST ALWAYS BE UTILIZED WHILE USING THE CHAINSAW ON THE TREE TRUNK.

- Push the Bucking Spikes into the tree trunk by pushing on the Rear Handle (6).
- Push the Wrap Around Handle (4) in the direction of the cutting line.
- The Bucking Spikes must reset for further saw guiding when necessary.
- Using a Bucking Spikes when cutting trees and thick branches can ensure your safety and decrease the working strength and vibration level.

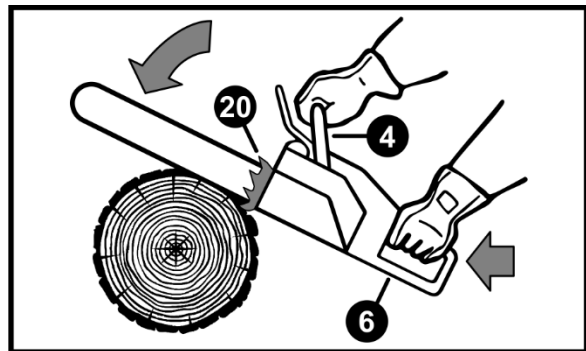

IF THERE'S DEBRIS BETWEEN THE CUTTING MATERIAL AND CHAINSAW, TURN OFF THE MACHINE.

- Wait until it stops completely.
- Wear safety gloves and remove the debris.
- If the chain must be removed, please follow the instructions of installation in manual.
- A trial run must be conducted after the cleaning and re-installation.

NOTE IF VIBRATION OR MECHANICAL NOISE IS DISCOVERED, PLEASE STOP THE USE, AND CONTACT YOUR DEALER.

NOTCHING UNDERCUT

- Make a notch 1/3 the diameter of the tree, perpendicular to the direction of falls as illustrated.
- Make the lower horizontal notching cut first. This will help to avoid pinching either the saw chain or the guide bar when the second notch is being made.

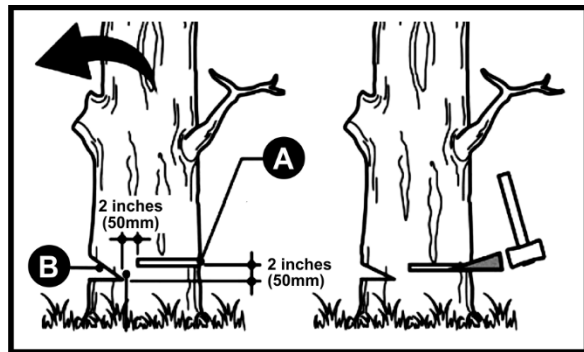

FELLING BACK CUT

- Make the felling back cut at least 2 inches (50mm) higher than the horizontal notching cut as illustrated in Figure 19.
- Keep the felling back cut parallel to the horizontal notching cut.
- Make the felling back cut so enough wood is left to act as a hinge.
- The hinge wood keeps the tree from twisting and falling in the wrong direction.
- Do not cut through the hinge.
- As the felling gets close to the hinge, the tree should begin to fall.

⚠ CAUTION! IF THERE IS ANY CHANCE THAT THE TREE MAY NOT FALL IN THE DESIRED DIRECTION OR IT MAY ROCK BACK AND BIND THE SAW CHAIN, STOP CUTTING BEFORE THE FELLING BACK CUT IS COMPLETE AND USE WEDGES OF WOOD, PLASTIC, OR ALUMINUM TO OPEN THE CUT AND DROP THE TREE ALONG THE DESIRED LINE OF FALL.

⚠ IMPORTANT! WHEN THE TREE BEGINS TO FALL REMOVE THE CHAINSAW FROM THE CUT, STOP THE MOTOR, PUT THE CHAINSAW DOWN, THEN USE THE RETREAT PATH PLANNED. BE ALERT FOR OVERHEAD LIMBS FALLING AND WATCH YOUR FOOTING.

LIMBING A TREE

LIMBING IS REMOVING THE BRANCHES FROM A FALLEN TREE.

- When limbing leave larger lower limbs (C) to support the log off the ground.
- Remove the small limbs in one cut as illustrated (D).
- Branches under tension should be cut from the bottom up to avoid binding the chainsaw.
- Keep work off of the ground and leave supporting limbs (C) until the log is completely cut.

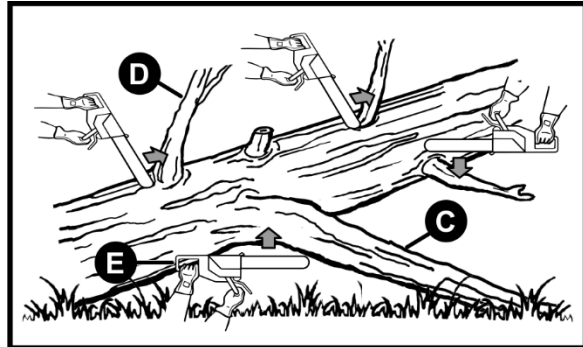

LIMBING A FELLED TREE

FIRST CHECK WHICH WAY THE LIMB IS BENT.

1. Then make a shallow cut into the compressed side to prevent the limb from being torn.
2. Cut through from the tensed side.

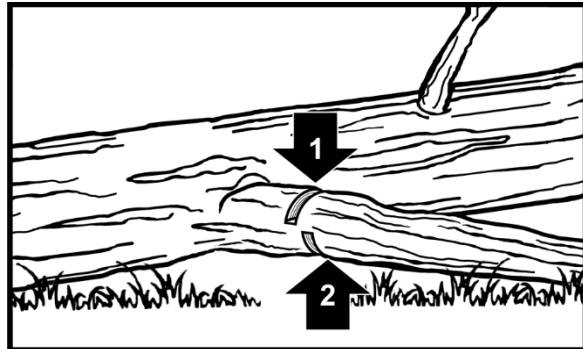

PRUNING

1. Cut up from the bottom one-third.
2. Finish by sawing down from the top.

⚠ CAUTION!

DO NOT USE AN UNSTABLE FOOTHOLD OR A STEPLADDER.
DO NOT OVERREACH.
DO NOT CUT ABOVE SHOULDER HEIGHT.
ALWAYS USE BOTH HANDS TO GRIP THE SAW.

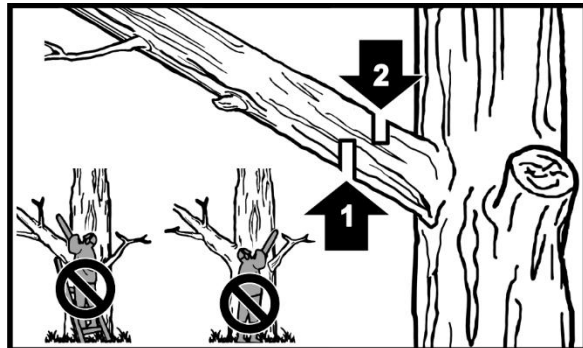

BUCKING A LOG

BUCKING IS CUTTING A LOG INTO LENGTHS.

- It is important to make sure your footing is firm, and your weight is evenly distributed on both feet.
- When possible, the log should be raised and supported by the use of limbs, logs, or chocks.
- When the log is supported along its entire length as illustrated, it is cut from the top (Overbuck) and avoid cutting the earth,

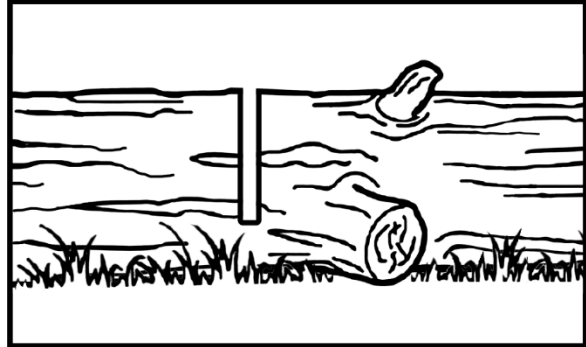

SUPPORTING A LOG

WHEN THE LOG IS SUPPORTED ON ONLY ONE END.

1. Cut 1/3 the diameter from the underside (Underbuck).
2. Then make the finished cut by Overbucking to meet the first cut.

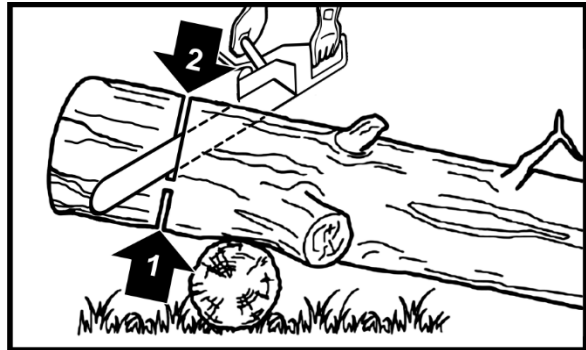

WHEN THE LOG IS SUPPORTED ON BOTH ENDS.

1. Cut 1/3 of the diameter from the top (Overbuck).
2. Then make the finished cut by Underbucking the lower 2/3 to meet the first cut.

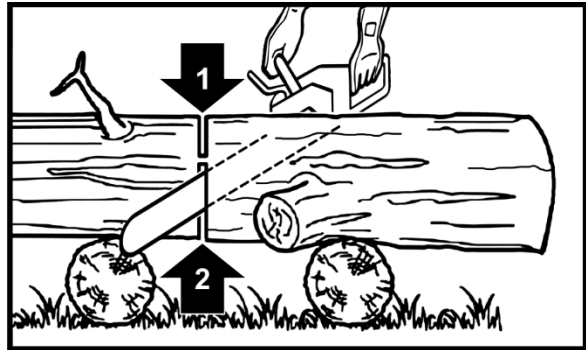

14-in, 37.2CC CHAINSAW

WHEN BUCKING ON A SLOPE ALWAYS STAND ON THE UPHILL SIDE OF THE LOG BECAUSE LOG MAY ROLL DOWNHILL.

- To maintain complete control when “cutting through”, release the cutting pressure near the end of the cut without relaxing your grip on the chainsaw handles.
- Do not let the saw chain contact the ground.
- After completing the cut, wait for the saw chain to stop before you move the chainsaw.
- Always stop the motor before moving from tree to tree.

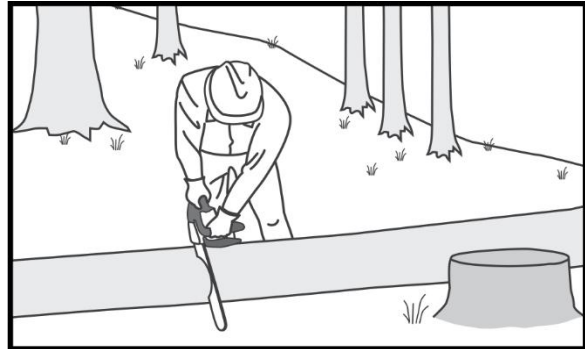

8. MAINTENANCE

⚠ WARNING! TO PREVENT SERIOUS INJURY FROM ACCIDENTAL STARTING: Turn the Power Switch of the equipment to its “OFF” position, wait for the engine to cool, and disconnect the spark plug cap before performing any inspection, maintenance, or cleaning procedures.

⚠ TO PREVENT SERIOUS INJURY FROM EQUIPMENT FAILURE: Do not use damaged equipment. If abnormal noise, vibration, or excess smoking occurs, maintenance procedures, including any not detailed in this manual, will need to be performed by a qualified technician for safety. If you have any doubts about your ability to safely service the equipment or engine, contact customer service and have an approved technician service the equipment instead.

CLEANING, MAINTENANCE, AND LUBRICATION

1. **BEFORE EACH USE:** Inspect the general condition of the tool. Check for:
 - Loose hardware
 - Misalignment or binding of moving parts
 - Cracked or broken parts
 - Dull or damaged saw chain
 - Any other condition that may affect its safe operation
2. **BEFORE FIRST USE AND BEFORE EACH USE THEREAFTER:** Make sure the Oil Tank is filled with oil (not included). Refer to SPECIFICATIONS CHART for oil type.
3. **IF THE SAW CHAIN BECOMES LOOSE:** Adjust the Saw Chain tension as described under ADJUSTING SAW CHAIN TENSION.
4. **PERIODICALLY OR WHEN REPLACING SAW CHAIN.** Turn the Chain Guide Bar over to distribute the wear on it. Replace the Guide Bar when bent, cracked, or when the Saw Chain moves excessively from side to side on the Guide Bar due to wear. Refer to CHAIN GUIDE BAR CARE.

⚠ WARNING! TO PREVENT SERIOUS INJURY:

Replace the Saw Chain and Guide Bar with only an identical Saw Chain and Guide Bar.

- AFTER USE:** When the Saw has cooled completely, clean thoroughly and cover the Chain Guide Bar with the Chain Guide Bar Sheath. Do not use solvents. Do not immerse this tool in liquid. Store the tool indoors out of children’s reach. See LONG-TERM STORAGE for complete storage instructions.

NOTE THIS MAINTENANCE SCHEDULE IS INTENDED SOLELY AS A GENERAL GUIDE. IF PERFORMANCE DECREASES OR IF EQUIPMENT OPERATES UNUSUALLY, CHECK SYSTEMS IMMEDIATELY.

The maintenance needs of each piece of equipment will differ depending on factors such as duty cycle, temperature, air quality, fuel quality, and other factors. If you have doubts about your ability to safely service this tool, contact customer service and have an approved technician service the equipment instead.

NOTE THE FOLLOWING PROCEDURES ARE IN ADDITION TO THE REGULAR CHECKS AND MAINTENANCE EXPLAINED AS PART OF THE REGULAR OPERATION OF THE ENGINE AND EQUIPMENT.

Procedure	Before Each Use	Monthly or every 10 hours of use	Every 3 months or every 20 hours of use	Every 6 months or every 50 hours of use	Yearly or every 100 hours of use	Every 2 Years
Check engine fuel/oil mixture level	X	X				
Change fuel filter	X	X			X	X
Clean air filter			X *	X	X	X
Check and clean spark plug				X	X	X
Check/adjust idle speed	X	X				
1.Clean fuel tank and carburetor 2.Clean carbon build-up from combustion chamber					X **	X **
Replace fuel line if necessary						X **

* Service more frequently when used in dusty areas.

** Contact customer service. An authorized service technician should service these items.

14-in, 37.2CC CHAINSAW

SAW CHAIN CARE, SHARPENING AND REPLACING

⚠ CAUTION! WEAR HEAVY-DUTY WORK GLOVES WHEN HANDLING THE SAW CHAIN.

1. For smooth and safe operation, always keep the Saw Chain cutters sharp.
2. Have the cutters sharpened by a qualified technician when you notice any of the following symptoms:
 - a. The sawdust becomes powder-like.
 - b. You can't make the cut without extra force.
 - c. The Chainsaw does not cut straight.
 - d. Vibration increases.
 - e. Fuel consumption increases.
3. A Saw Chain that is damaged or too worn to be restored to a usable condition by sharpening will need to be replaced. Refer to GUIDE BAR / SAW CHAIN INSTALLATION/REPLACEMENT.

⚠ WARNING! TO PREVENT SERIOUS INJURY:
Replace the Saw Chain only with an identical Saw Chain. Refer to section GUIDE BAR AND SAW CHAIN INSTALLATION AND ADJUSTMENT.

Don't use a replacement saw chain unless it has been designated as meeting the kickback performance requirements in **ANSI/OPEI B175.1-2021** on that specific power head. A low-kickback saw chain is a chain that has met the kickback performance requirements of **ANSI/OPEI B175.1-2021** when tested according to the provisions specified in **ANSI/OPEI B175.1-2021**.



CUTTER SETTING STANDARDS

BEFORE FILING:

MAKE SURE THE SAW CHAIN IS HELD SECURELY. MAKE SURE THE ENGINE IS STOPPED.

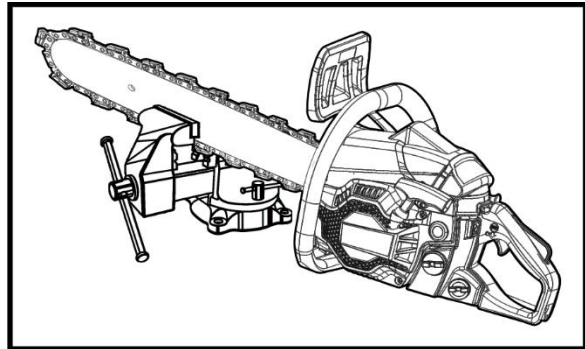
1. Use a round file of the proper size for your chain. See the chart below.
2. Place your file on the cutter and push straight forward.
3. Keep the file position as designated in the chart below.
4. After every cutter has been set, check the depth gauge and file it to the proper level as illustrated.
5. Be sure to round off the front edge to reduce the chance of kickback or tie-strap breakage.
6. Make sure every cutter has the same length and edge angles as illustrated.

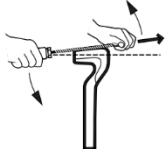
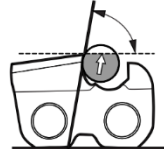
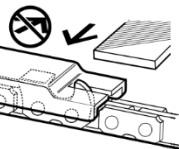

FILE DIAMETER	TOP PLATE ANGLE	DOWN ANGLE	SIDE ANGLE	DEPTH GAUGE
				
5/32 inch (3.97mm)	30°	0°	80°	0.025 inch (0.635mm)

CHAIN GUIDE BAR CARE

1. Remove the Chain Guide Bar periodically to clean and lubricate the Bar Sprocket through the Bar Grease port (B).
2. Remove sawdust and sap from the Bar Groove using a Guide Bar cleaning tool (sold separately), then lubricate the nose sprocket at ports with grease.
3. Deburr rails of Guide Bar as needed. Use a flat file to make the side edges square.
4. Reverse the Guide Bar when replacing the Saw Chain to prevent uneven wear.

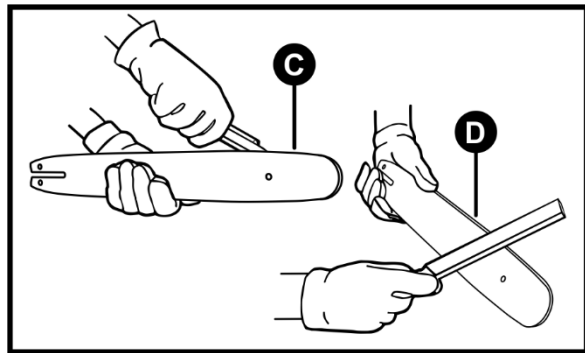
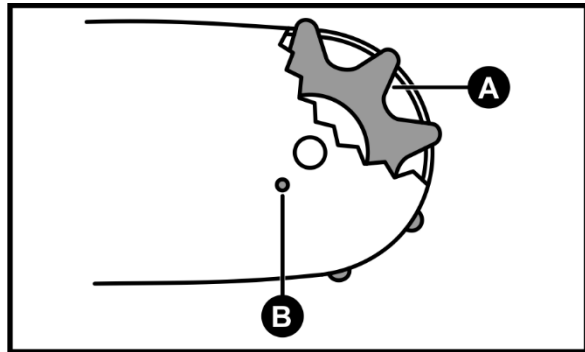

THE RAILS OF THE GUIDE BAR GROOVE SHOULD ALWAYS BE PARALLEL TO EACH OTHER.

- Place a ruler along the surface of the Guide Bar and Saw Chain.
- If there is a gap between the ruler and guard, the bar is normal (E).
- If there is no gap between the ruler and guard, the bar is worn (F).

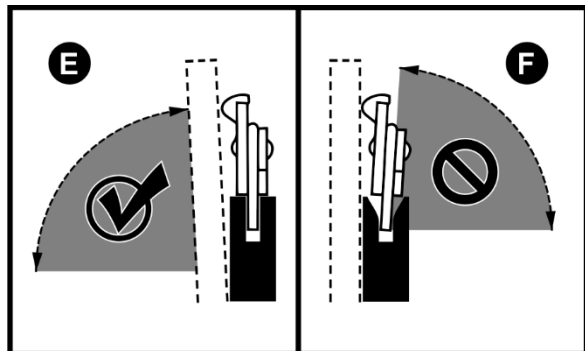

14-in, 37.2CC CHAINSAW

SPARK PLUG MAINTENANCE

1. Remove the Air Filter Cover.
2. Disconnect Spark Plug Cap from end of plug. Clean out debris from around Spark Plug.
3. Using a spark plug wrench, remove the Spark Plug.
4. Inspect the Spark Plug: If the electrode is oily, clean it using a clean, dry rag. If the electrode has deposits on it, polish it using emery paper. If the white insulator is cracked or chipped, the spark plug needs to be replaced

Recommended Spark Plugs	
Bosch®	L8RTF
Champion®	RCJ7Y
NGK®	BPMR7A

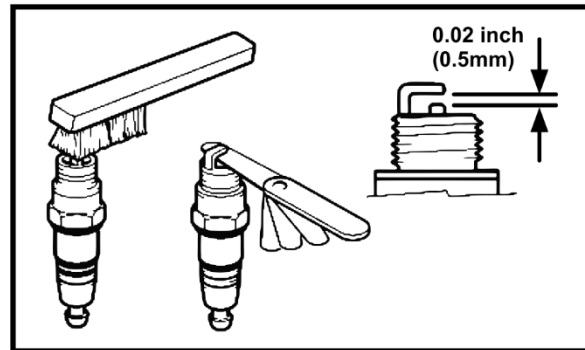

NOTE USING AN INCORRECT SPARK PLUG MAY DAMAGE THE ENGINE.

5. When installing a new spark plug, adjust the plug's gap to the specification on the Specifications chart. Do not pry against the electrode, the spark plug can be damaged.
6. Install the new spark plug or the cleaned spark plug into the engine.
 - **Gasket style:** Finger-tighten until the gasket contacts the cylinder head, then tighten about 1/2-2/3 turn more.
 - **Non-gasket style:** Finger-tighten until the plug contacts the cylinder head, then tighten about 1/16 turn more.

NOTE TIGHTEN THE SPARK PLUG PROPERLY. IF LOOSE, THE SPARK PLUG WILL CAUSE THE ENGINE TO OVERHEAT. IF OVERTIGHTENED, THE THREADS IN THE ENGINE BLOCK WILL BE DAMAGED.

7. Reattach the Spark Plug Cap securely.

AIR FILTER MAINTENANCE

CLEAN OR REPLACE THE AIR FILTER AS DESCRIBED BELOW:

1. Pry open the two metal Air Filter Cap Retaining Straps.
2. Remove the Air Filter Cover (G).
3. Remove Lock Nut and the Air Filter (H).

⚠ IMPORTANT! INSPECT THE AIR FILTER. IF DIRTY OR CLOGGED, REPLACE IT WITH AN AUTHORIZED AIR FILTER.

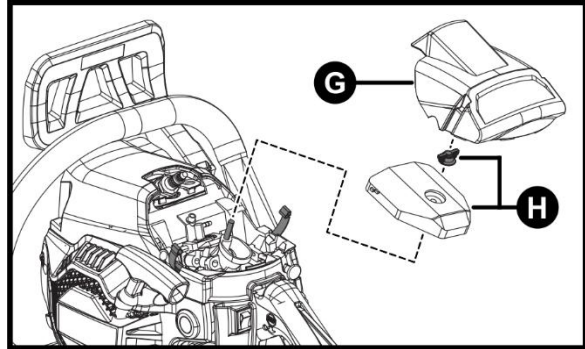

4. To clean the Air Filter surface, lightly tap its corners against a hard surface. In a well-ventilated area away from the bystanders, use pressurized air to blow dust out of the Air Filter from the inside.
5. When the cleaning is complete install the Air Filter OR install a NEW Air Filter.
6. Place the Air Filter in the holding compartment and secure with the Lock Nut.
7. Relock the Air Filter Cover with the metal straps until they click.

NOTE TO PREVENT INJURY FROM DUST AND DEBRIS, WEAR ANSI-APPROVED SAFETY GOGGLES, NIOSH-APPROVED DUST MASK/RESPIRATOR, AND HEAVY-DUTY WORK GLOVES.

FUEL FILTER MAINTENANCE

CLEAN OR REPLACE THE FUEL FILTER AS DESCRIBED BELOW:

1. Remove the Fuel Tank Cap (I) from the Fuel Tank (J).
2. Use a suction pump (not included) to pump and remove any fuel in the Fuel Tank into a proper gasoline container.
3. Use a piece of wire with a hook on one end to carefully extract the Fuel Filter from the Fuel Tank
4. Remove the used Filter from Fuel Line. Clean or attach a new Filter to the Fuel Line.
5. Reinsert the assembly into the Fuel Tank.
6. Replace Fuel Tank Cap and tighten securely.

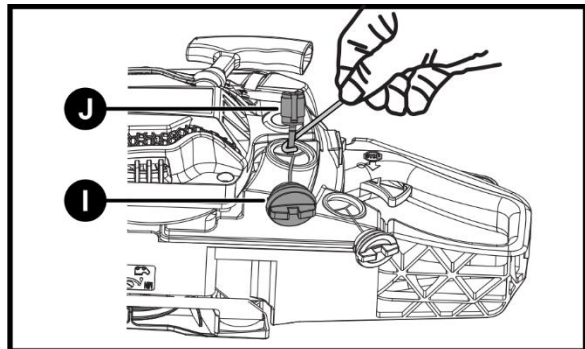

PERIODICAL SERVICE POINTS

FRONT AND REAR ABSORBER SPRING

LOCATED ON CHAINSAW WHERE WRAPAROUND HANDLE (4) MOUNTS TO THE CHAINSAW ASSEMBLY (A). REFER TO COMPONENTS AND CONTROLS.

- Check for cracks and for excessive wear.
- Replace if spring is deformation.
- Use only the spare parts which are listed in this manual. Using the other spare part can cause serious injury.

SPROCKET (K)

REMOVE THE CHAIN DRIVE COVER AS DESCRIBED IN REMOVING THE CHAIN DRIVE COVER

- Check for cracks and for excessive wear interfering with the chain drive.
- If the wear is considerable, replace it with new one.
- Never fit a new chain on a worn Sprocket, or a worn Chain on a new Sprocket.

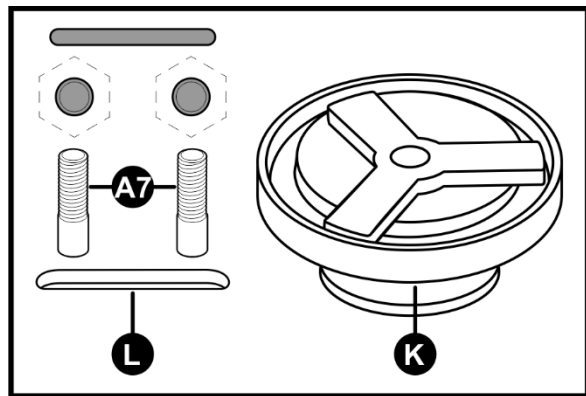

CHAIN OILING PORT

- Located on Chainsaw above the two the Guide Bar Bolts (A7)
- Dismount the guide bar and check the Chain Oiling Port (L) for clogging.

CYLINDER FINS

DUST CLOGGING BETWEEN THE CYLINDER FINS WILL CAUSE OVERHEATING OF THE ENGINE.

- Periodically check and clean the cylinder fins after removing the air cleaner and the cylinder cover.
- When installing the cylinder cover, make sure that switch wires and grommets are positioned correctly in place.

LONG-TERM STORAGE

WHEN THE EQUIPMENT IS TO REMAIN IDLE FOR LONGER THAN 20 DAYS, PREPARE THE ENGINE FOR STORAGE AS FOLLOWS:

- 1. CLEANING:** Wait for Engine to cool, then clean Engine with dry cloth.

NOTE DO NOT CLEAN USING WATER. THE WATER WILL GRADUALLY ENTER THE ENGINE AND CAUSE RUST DAMAGE. APPLY A THIN COAT OR RUST PREVENTATIVE OIL TO ALL METAL PARTS.

2. FUEL:

⚠ WARNING!



TO PREVENT SERIOUS INJURY FROM FIRE:

Drain the Fuel Tank in a well-ventilated area away from ignition sources. If the Engine is hot from use, shut the Engine off and wait for it to cool before draining fuel. Do not smoke.

- a. Remove the Fuel Tank Cap and drain any remaining fuel into an approved storage container.
- b. Press the Prime Bulb 10 times.
- c. Drain any residual fuel into the storage container.
- d. Start the Engine and run at idle until the Engine stalls from lack of fuel.
- e. Replace Fuel Tank Cap and tighten securely.

3. LUBRICATION:

- a. Clean out area around spark plug. Remove spark plug and pour 7.4ml (½ tablespoon) of 2-stroke oil into cylinder through spark plug hole.
- b. Insert spark plug, but leave spark plug cap disconnected.
- c. Pull Starter Handle to distribute oil in cylinder. Stop after one or two revolutions when you feel the piston start the compression stroke (when you start to feel resistance).
- d. Remove all residual bar and chain oil from the Oil Tank.

4. STORAGE AREA: Cover and store in a dry, level, well-ventilated area out of reach of children. The storage area should also be away from ignition sources, such as water heaters, clothes dryers, and furnaces.

5. AFTER STORAGE: Before starting the Engine after storage, follow the checks and procedures under Controls and Operations beginning on page 15. If using pre-mixed fuel that has been stored, keep in mind that during storage some of the gasoline in the fuel evaporates while the 2-stroke oil does not, altering the gasoline-to-oil mix ratio. Running the Engine with an improper mixture WILL permanently damage the Engine. Use freshly mixed fuel when starting the Engine after storage.

9. TROUBLESHOOTING

Problem	Possible Causes	Problem Solutions
Engine will not start	FUEL RELATED	FUEL RELATED
	No fuel in tank.	Fill fuel tank with fresh 87+ octane stabilizer-treated unleaded gasoline/oil mixture only. Do not use gasoline with more than 10% ethanol (E15, E20, E85, etc.).
	Choke not in START position, cold engine.	Move Choke to START position.
	Gasoline with more than 10% ethanol used. (E15, E20, E85, etc.)	Clean out ethanol-rich gasoline from fuel system. Replace components damaged by ethanol. Use fresh 87+ octane stabilizer-treated unleaded gasoline/oil mixture only. Do not use gasoline with more than 10% ethanol (E15, E20, E85, etc.).
	Low quality or deteriorated, old gasoline/oil mixture.	Use fresh 87+ octane stabilizer-treated unleaded gasoline/oil mixture. Do not use gasoline with more than 10% ethanol (E15, E20, E85, etc.).
	Carburetor not primed.	Press the Prime Bulb several times to prime.
	Dirty fuel passageways.	Clean out passageways using fuel additive. Heavy deposits may require further cleaning.
Carburetor is flooded.	Turn Choke Knob to RUN position. Pull Starter Handle 10-20 times to clear out Carburetor, then attempt to start with normal process.	



FOLLOW ALL SAFETY PRECAUTIONS WHENEVER DIAGNOSING OR SERVICING THE EQUIPMENT OR ENGINE.

Problem	Possible Causes	Problem Solutions
The engine will not start (continued)	IGNITION (SPARK) RELATED:	IGNITION (SPARK) RELATED:
	Spark plug cap is not connected securely.	Connect spark plug cap properly.
	Spark plug electrode wet or dirty.	Clean spark plug.
	Incorrect spark plug gap.	Correct spark plug gap.
	Spark plug cap broken.	Replace spark plug cap.
	Incorrect spark timing or faulty ignition system	Contact customer service and have an approved technician diagnose/repair ignition system.
	COMPRESSION RELATED:	COMPRESSION RELATED:
Cylinder not lubricated. Problem after long storage periods.	Pour ½ tablespoon of oil into spark plug hole. Crank the engine a few times and try to start again.	
Loose or broken spark plug. (Hissing noise will occur)	Tighten spark plug. If that does not work, replace the spark plug.	
Engine misfires	Spark plug cap loose.	Check cap and wire connections.
	Incorrect spark plug gap or damaged spark plug.	Re-gap or replace spark plug.
	Defective spark plug cap.	Replace spark plug cap.
	Old or low quality gasoline/oil mixture.	Use only fresh 87+ octane stabilizer-treated unleaded gasoline/oil mixture. Do not use gasoline with more than 10% ethanol (E15, E20, E85, etc.).
	Incorrect compression.	Diagnoses and repair compression. (Use Engine will not start: COMPRESSION RELATED section.)

 **FOLLOW ALL SAFETY PRECAUTIONS WHENEVER DIAGNOSING OR SERVICING THE EQUIPMENT OR ENGINE.**

14-in, 37.2CC CHAINSAW

Problem	Possible Causes	Problem Solutions
The engine stops suddenly	Fuel tank empty or full of impure or low quality gasoline/oil mixture.	Fill fuel tank with fresh 87+ octane stabilizer-treated unleaded gasoline/oil mixture. Do not use gasoline with more than 10% ethanol (E15, E20, E85, etc.).
	Defective breather valve creating vacuum, preventing proper fuel flow.	Test/replace breather valve.
	Faulty magneto.	Contact customer service and have an approved technician service magneto.
	Disconnected or improperly connected spark plug cap.	Secure spark plug cap.
The engine stops when under heavy load	Dirty air filter	Clean element.
	The engine is running cold.	Allow engines to warm up prior to operating equipment.
Engine knocks	Old or low quality gasoline/oil mixture.	Fill fuel tank with fresh 87+ octane stabilizer-treated unleaded gasoline/oil mixture. Do not use gasoline with more than 10% ethanol (E15, E20, E85, etc.).
	Engine overloaded.	Do not exceed the equipment's load rating.
	Incorrect spark timing, deposit buildup, worn engine, or other mechanical problems.	Contact customer service and have an approved technician diagnosis and service engine.



FOLLOW ALL SAFETY PRECAUTIONS WHENEVER DIAGNOSING OR SERVICING THE EQUIPMENT OR ENGINE.

Problem	Possible Causes	Problem Solutions
Lack of power, Poor acceleration, Rough idling	Check the fuel for water or substandard mixture.	Replace with proper fuel.
	Check air filter and fuel filter for clogging.	Clean.
	Check the carburetor for inadequate adjustment.	Readjust speed needles.
After sudden impact, the engine will run, but equipment will not operate	Shaft key or other shear pin broken by impact to disconnect engine and limit damage.	Contact customer service and have an approved technician check and replace broken shaft key or other shear pins.
Engine runs, but Chain does not rotate	Chain tension is too tight.	Adjust Saw Chain tension.
	Guide Bar and/or Chain damaged.	Inspect Guide Bar and Chain for damage. Replace the Guide Bar and Chain if necessary.
	Chain drive sprocket worn.	Contact customer service and have an approved technician service tool.
	Chain brake is engaged.	Disengage the chain brake.
Engine runs, Chain rotates but does not cut or cuts poorly	Saw Chain not tensioned properly.	Tension Saw Chain properly.
	Saw Chain dull.	Sharpen Saw Chain or replace.
	Saw Chain installed backwards.	Reverse direction of Saw Chain.
Chain Oil does not come out	Check oil for substandard quality.	Replace.
	Check oil passage and ports for clogging.	Clean.
Chain comes off Guide Bar	Chain tension is too loose.	Adjust Saw Chain tension.
	Guide Bar and Chain is not installed correctly.	Review and correct Guide Bar and Chain installation.
Guide Bar and Chain running hot	Chain tension is too tight.	Adjust Saw Chain tension.
	Oil Tank empty.	Check/refill Oil Tank.

 **FOLLOW ALL SAFETY PRECAUTIONS WHENEVER DIAGNOSING OR SERVICING THE EQUIPMENT OR ENGINE**

14-in, 37.2CC CHAINSAW

10. EXPLODES VIEWS AND PARTS

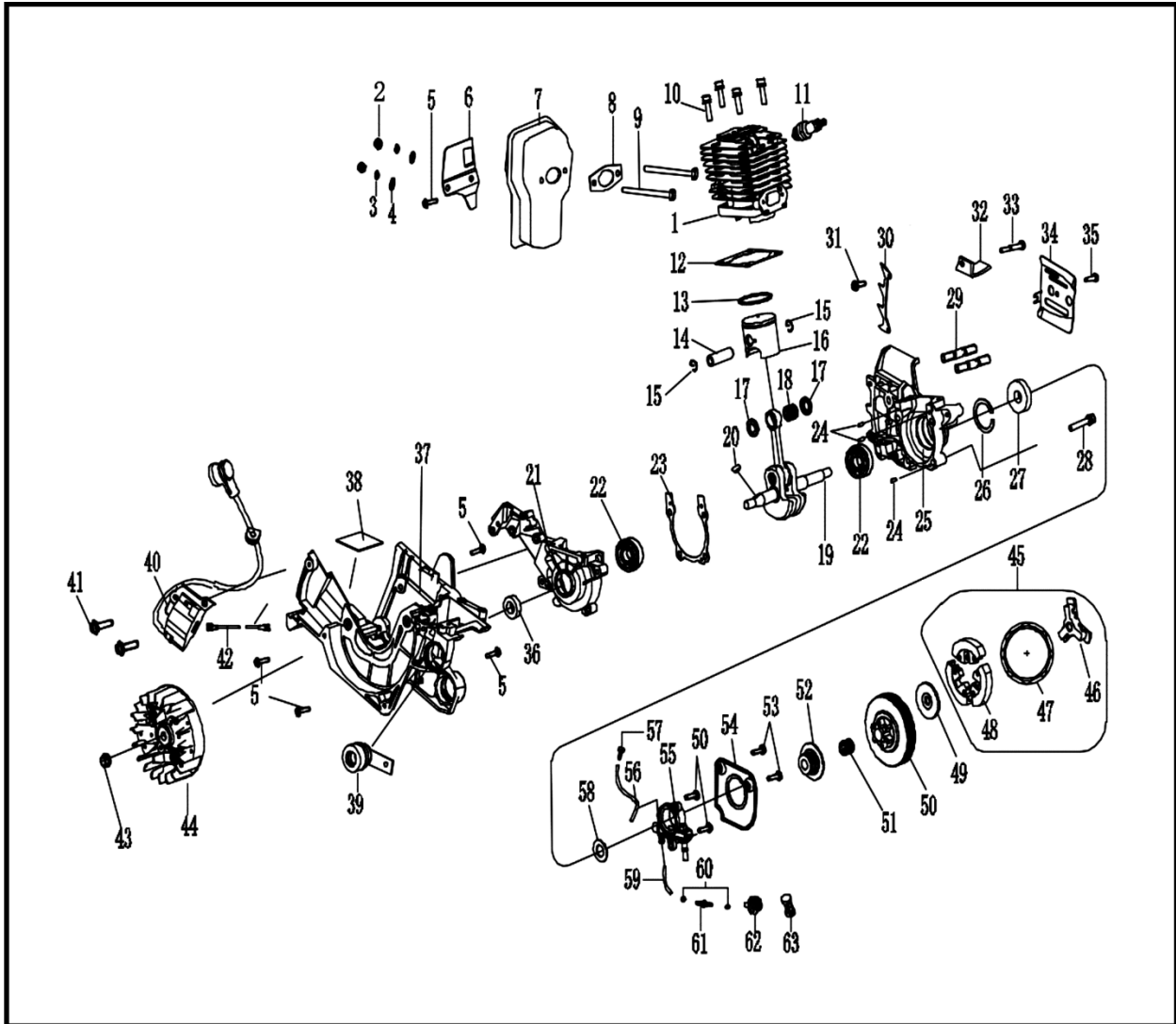

NO	PART NAME	QTY	PART #
1	CYLINDER BODY	1	20056584
2	NUT M5	2	20061357
3	WASHER 5	2	20054560
4	WASHER 5	2	20054561
5	SCREW M5 X 14	5	20060972
6	MUFFLER COVER PLATE (MUFFLER)	1	20056612
7	MUFFLER BODY	1	
8	MUFFLER SEALING GASKET	1	20050659
9	MUFFLER CONNECTING SCREW	2	20056586
10	SCREW M5 X 20	4	20054552
11	SPARK PLUG NHSP LD L8RTF	1	20050466
12	CYLINDER SEALING GASKET	1	20050657
13	PISTON RING	1	20053103
14	PISTON PIN	1	20053104
15	PISTON PIN CIRCLIP	2	20053105
16	PISTON	1	20053106
17	NEEDLE BEARING RING	2	20056604
18	NEEDLE BEARING 10 X 14 X 11	1	20056608
19	CRANK SHAFT COMPONENTS	1	20056605
20	SEMICIRCULAR KEY 3 X 3.5 X 10	1	20054650
21	LEFT CRANK CASE	1	20053085
22	BEARING 6201 GRADE D 12 X 32 X 10	2	20061605
23	CASE BODY SEALING GASKET	1	20050669
24	PIN 3 X 9	3	20054568
25	RIGHT CRANK CASE	1	20053094
26	SHIELD RING 32	1	20061518
27	OIL SEAL 12 X 32 X 5.5	1	20056597
28	SCREW M5 X 30	4	20061084
29	DOUBLE-SCREW BOLT AYM8-M8 X 26-8.8	2	20054554
30	SPIKED BUMPER	1	20054642
31	SCREW M5×12	1	20054549
32	CHAIN CATCHER	1	20055118

NO	PART NAME	QTY	PART #
33	CHAIN CATCHER SCREW	1	20056589
34	DAMPER	1	20055115
35	SCREW M4 X 10	1	20054537
36	OIL SEAL 12 X 22 X 7	1	20056600
37	BASE	1	20064244
38	BASE ALUMINUM PARTITION	1	20055133
39	LONG SHOCK ABSORBER SEAT	1	20056618
40	IGNITER	1	20050722
42	EXTINCTION CONDUCTOR (IGNITER)	1	
41	SCREW M4 X 14	2	20061071
43	NUT M8 X 1	1	20054556
44	FLYWHEEL ASSEMBLY	1	20050726
45	CLUTCH ASSEMBLY	1	20056591
46	RETAINER	1	
47	CLUTCH EXTENSION SPRING	1	
48	SHOE BLOCK	3	
49	CLUTCH ADJUSTING WASHER	1	20055114
50	CLUTCH SHELL	1	20056583
51	NEEDLE BEARING 10 X 13 X 13	1	20056594
52	WORM	1	20056587
53	SCREW M4 X 14	4	20060940
54	COVER PLATE	1	20056555
55	OIL PUMP	1	20056842
56	OIL OUTGOING TUBE	1	20056830
57	WORM WASHER 10 X 18 X 1	1	20056588
58	OIL INGOING TUBE	1	20056834
59	OIL TUBE CLIP	2	20054663
60	OIL TUBE TIE-IN	1	20056837
61	NOZZLE	1	20056838
62	OIL FILTER SCREEN	1	20056841
63	OIL SPRAY NOZZLE	1	20056833

14-in, 37.2CC CHAINSAW

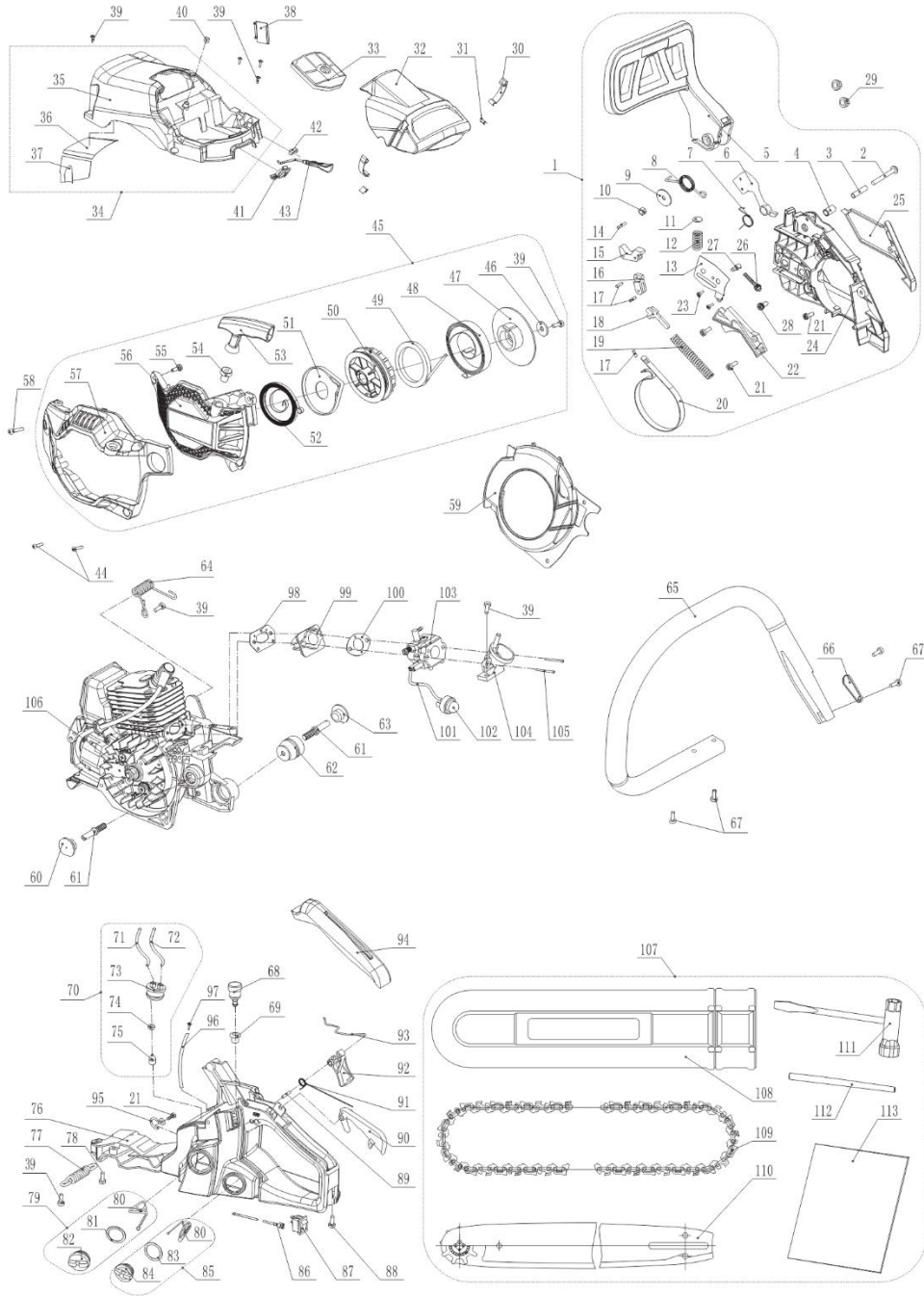

NO	PART NAME	QTY	PART #
1	RIGHT COVER ASSEMBLY	1	20085235
2	SCREW M5 X 40	1	20054591
3	BAFFLE SLEEVE	1	20054590
4	HEAVY HAMMER BUSHING	1	20054589
5	FRONT BEZEL	1	20074037
6	HAMMER	1	20054592
7	HAMMER TORSION SPRING	1	20054587
8	BRAKE SPRINGS	1	20054588
9	WASHER 5.2 X 23 X 1.2	1	20056814
10	HEX LOCK NUT M5	1	20054559
11	SPRING SEAT	1	20054586
12	FRONT BEZEL PRESS SPRING	1	20054585
13	TENSIONER COVER	1	20055141
14	PIN 3 X 14	1	20054569
15	MAIN BAR	1	20056804
16	SECONDARY TIE ROD	1	20056786
17	PIN 3 X 9	3	20054568
18	BRAKE LEVER	1	20055140
19	BRAKE SPRINGS	1	20054686
20	BRAKE BELTS	1	20055139
21	SELF-TAPPING SCREW ST4 X 10	3	20061008
22	BRAKE SPRING COVER	1	20056770
23	SELF-TAPPING SCREW ST4 X 10	2	20054543
24	RIGHT COVER	1	20057139
25	TENSIONING GEARS	1	20054692
26	TENSION SCREWS	1	20054690
27	TENSION BLOCK	1	20054691
28	SIGN COVER RT	1	20057140
29	HEX FLANGE NUT M8	2	20054556
30	SNAP	2	20057352
31	CARD AND RETENTION PLATE	2	20057353
32	EMPTY FILTER COVER	1	20074038
33	AIR FILTER	1	20056844
34	UPPER COVER ASSEMBLY	1	20086980
35	COVERED	1	20057141
36	UPPER COVER ALUMINUM PARTITION	1	20055157
37	AL PARTITION SIDE UPPER COVER	1	20055143
38	FREEZE BLOCK	1	20056829
39	SELF-TAPPING SCREW ST5 X 16	8	20054536
40	SHOCK ABSORBERS	1	20054593
41	DUST PLATE	1	20056540

NO	PART NAME	QTY	PART #
42	TIE ROD HOLDER	1	20056552
43	DAMPER LEVER	1	20056572
44	SELF-TAPPING SCREW ST5 X 16	2	20054544
45	LAUNCHER ASSEMBLY	1	20085766
46	LARGE WASHERS	1	20054562
47	STARTER RATCHET	1	20056881
48	LARGE DISC SPRING	1	20055150
49	START THE DRAWSTRING 3 X 920	1	20056633
50	EASY BOOT DISK	1	20056883
51	DISC SPRING GLAND	1	20056497
52	STARTER DISC SPRING	1	20056498
53	STARTER HANDLE	1	20057781
54	DRAWSTRING SHEATH	1	20054579
55	SELF-TAPPING SCREW ST4 X 12	1	20060958
56	STARTER COVER LINING	1	20074036
57	INITIATOR COVER HOUSING	1	20057136
58	SELF-TAPPING SCREW ST5 X 19	1	20060977
59	DEFLECTOR	1	20056948
60	DUST CAPS	1	20054607
61	CHAIN BLOCK SCREWS	2	20056150
62	SHOCK ABSORBER SEAT	1	20056614
63	LARGE DUST CAP	1	20056543
64	LIFT HANDLE TWIST SPRING	1	20050100
65	HANDLES	1	20051850
66	TORSION SPRING GLAND	1	20055112
67	SELF-TAPPING SCREW ST5 X 25	4	20060937
68	BALANCER BODY ASSEMBLY	1	20054685
69	BALANCER HOLDER	1	20054580
70	FUEL SEAT ASSEMBLY	1	20073185
71	FUEL LINES 2.5 X 5 X 195	1	20055779
72	RETURN LINE 2.5 X 5 X 100	1	20054579
73	FUEL HEADER	1	20056638
74	COUNTERWEIGHT BLOCKS	1	20055136
75	GASOLINE FILTER COMPONENTS	1	20053111
76	BASE	1	20064362
77	BASE TENSION SPRING	1	20055110
78	SCREW M5 X 14	1	20060972
79	FUEL PORT COVER PARTS	1	20085765
80	ANTI-DROP PLATE	1	20054582
81	O-TYPE RUBBER SEAL 24.7 X 3.55	1	20054574
82	FUEL PORT COVER	1	20056909

14-in, 37.2CC CHAINSAW

NO	PART NAME	QTY	PART #
85	OIL PORT COVER PART	1	20073421
80	ANTI-DROP PLATE	1	20054582
83	O-TYPE RUBBER SEAL 19 X 3.5	1	20054575
84	OIL PORT COVER	1	20056920
87	FLAMEOUT SWITCH	1	20050680
86	GROUND WIRE	1	
88	SELF-TAPPING SCREW ST5 X 25	1	20060961
89	PIN 5 X 25	1	20061567
90	TRIGGER CONTROL ARM	1	20056853
91	TRIGGER TWIST SPRING	1	20054680
92	TRIGGER	1	20056648
93	THROTTLE PUSHER	1	20055147
94	HANDLE COVER	1	20056873
95	GREASE NOZZLE RETAINING RING	1	20055135

NO	PART NAME	QTY	PART #
96	SNORKEL 3.5 X 6.5 X 65	1	20056645
97	SELF-TAPPING SCREW ST4.2 X 16	1	20055736
98	AIR INTAKE GASKET	1	20050663
99	INTAKE PIPE	1	20056585
100	CARBURETOR GASKET	1	20050665
101	PUMP TUBING 2.5 X 5 X 175	1	20054576
102	OIL BUBBLES	1	20054581
103	CARBURETOR	1	20055119
104	INTAKE SEAT	1	20056596
105	CARBURETOR SCREW PARTS	2	20055129
108	GUIDE PLATE COVER 14-IN	1	30001135
111	SLEEVE BOARD HAND	1	30000051
112	FILE	1	30000047
113	INSTRUCTIONS	1	30019388

NO	PART NAME	QTY	PART #
109	OREGON 14-IN CHAIN	1	30001547
110	OREGON 14-IN GUIDE BAR	1	30001386

NO	PART NAME	QTY	PART #
109	PRORUN 14-IN CHAIN	1	30001960
110	PRORYN 14-IN GUIDE BAR	1	30028996

PRORUN regularly improves our products, and you may find slight differences between your machine and the descriptions contained within this operator's manual. Modifications can be made to the machine without notice and without the obligation to update the manual, providing that the essential safety and functional characteristics remain unaltered. Contact PRORUN Customer Service with any questions and for current specifications.

PRORUN / TOPSUN USA
 10130 Perimeter Parkway
 Suite 140
 Charlotte, NC 28216
 Customer Service: (844) 905-0882
 Email: info@proruntech.com
 Website: www.proruntools.com

Zhejiang Zhongjian Technology Co., Ltd
 Web: www.topsunpower.cc
 E-mail: sales@topsunpower.cc
 ADD: No.155 Mingyuan North AVE, Economic Development Zone,
 Yongkang, Zhejiang, 321300, P.R. CHINA
 Made in China