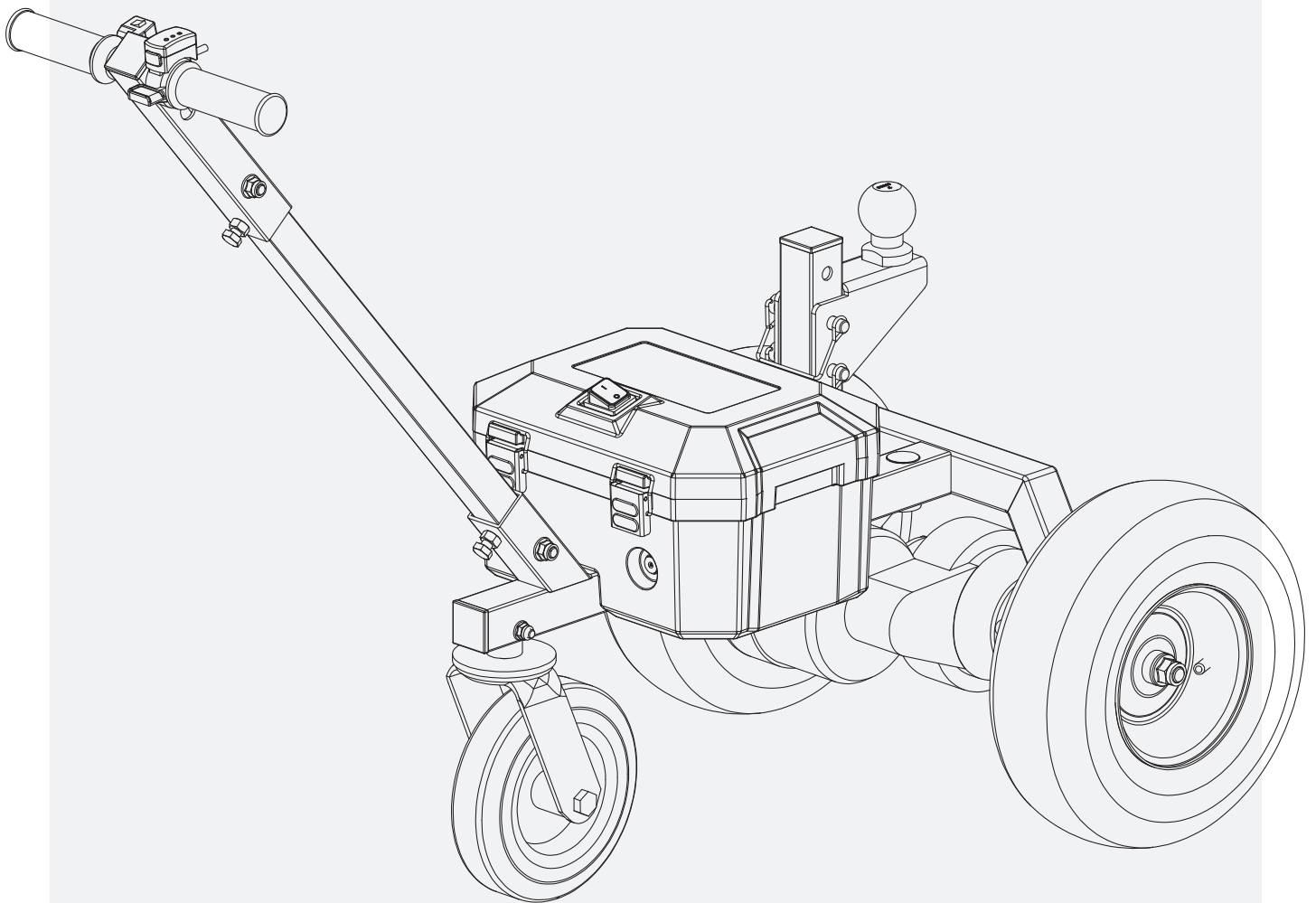




# Electric Power Dolly | GUO137

## Operator's Manual



**Warning:** Please read and thoroughly understand all instructions before operating. Failure to follow safety rules and other basic safety precautions may result in serious personal injury. Keep these instructions in a safe and easily accessible place so that they can be referred to when needed. Retain these instructions to assist in future servicing.

# INDEX

Warning	2-4
Safety Symbols	5
Technical Specifications	6
Main Components	7
Parts Overview	8
Assembly	9-12
Operation	13-15
Maintenance	16-20
Storage	20
Warranty	20
Troubleshooting	21
Parts Explosion	22

## Warning

- **DO NOT USE THIS PRODUCT TO MOVE TRAILER LOADED OR UNLOADED ACROSS ANYTHING OTHER THAN LEVEL PAVED SURFACES WITH A SLOPE OF LESS THAN 4°.**
- **DO NOT USE ON A SLOPED DRIVEWAY.**
- **DO NOT ATTEMPT TO USE THIS PRODUCT ON A BOAT LAUNCH. THIS PRODUCT IS NOT INTENDED TO REPLACE YOUR VEHICLE.**

## Installation and Operation

- Thoroughly review the "Installation and Operation Guidelines" and familiarize yourself with your electric dolly and its operation.
- **DO NOT** install or operate the dolly without reading or understanding the operator's manual.
- **DO NOT** exceed the maximum tow limit of this Trailer Dolly.
- **DO NOT** operate this dolly if you are under 16 years old.

## Connection and Safety Checks

- Check that the hitch ball and the trailer coupler are securely mounted, and that the brake control system of your trailer is in good working order before connecting it to the Trailer Dolly. **NEVER** pull a RV, yacht or any other trailer which has no brake or has faulty brakes.
- Always use factory approved mounting hardware, components and fittings.

## Operating Conditions

- **NEVER** pull a load with this Trailer Dolly on any steep grade or non-paved road. Always make sure the road surface is paved, level and **has a slope of less than 4 degrees**.
- **DO NOT** use the dolly to move people.
- **DO NOT** operate this dolly under the influence of alcohol or drugs.
- Be sure to remove any objects or obstacles that may hinder the safe operation of the dolly.

## Assembly and Maintenance

- When assembling, maintaining or prepping the dolly for storage, be sure to disconnect the power supply from the dolly.
- Never store the battery pack together with nails, screws, keys and other metallic or sharp objects. These items may cause short circuit of the battery terminal resulting in damage to the battery and may cause a fire, endangering personal safety.

## Battery Handling Guidelines

- Avoid contact with any fluid that leaks from the battery. Dispose of all batteries in the appropriate manner as these batteries will be dangerous and should no longer be used.
- Be sure to dispose of or recycle the battery according to local regulations.
- Before disposal, be sure to protect the terminal with insulating tape to prevent short circuit.
- **DO NOT** disassemble or tamper with the battery in any way. Any such tampering will automatically void your product warranty.
- **DO NOT** attempt to charge a damaged battery pack. Replace it immediately. A damaged battery pack may cause a short circuit or fire.
- Battery packs are covered by the manufacturer's product warranty and will be replaced by the vendor if the product is still under warranty.
- **DO NOT** burn the battery pack.

## Operating Regulations

- **DO NOT** operate the dolly in an environment containing explosive or combustible materials.
- When the dolly is not in use, be sure to cut off the battery power.
- Be sure to use the charger and lead-acid battery packs provided by manufacturer only. Other types of batteries may burst and cause personal injury.
- **DO NOT** use chargers with damaged wires or plugs. Chargers with such issues should be replaced immediately.
- **DO NOT** use the charger provided by manufacturer to charge other batteries.
- **DO NOT** charge the battery in a humid environment, and do not cover the charger with clothes or other items during charging.
- The use of accessories not recommended or provided by the charger manufacturer may lead to the risk of fire, electric shock or personal injury.

## Charging and Storage






- Always charge the battery at a temperature of 32°F-120°F (0°C-49°C).
- Always store the battery at a temperature of 32°F-86°F (0°C-30°C).
- Be sure to disconnect the charger when the battery is fully charged.
- Be sure not to completely discharge the battery. If not in use, be sure to charge the battery every 3 months.

## Disclaimer

- Before operation, please read and understand all instructions carefully, and the dolly can only be operated when the safety precautions and other basic safety preventive measures are strictly observed.
- The Company will not be responsible for any personal injury or property loss caused by man-made reasons or abnormal use.

# Safety Symbols

Some of the following symbols are used on this product. Please study them and learn their meanings. Proper interpretation of these symbols will help you to operate the product in a safe and responsible manner.

SYMBOL	DEFINITION
	<b>Read Operator's Manual in its entirety.</b> To reduce the risk of injury, user must read and understand operator's manual before using this product.
	<b>Footwear.</b> Always wear safety shoes or work boots when operating the machine. Sandals and slippers or open toe shoes or any type are strongly discouraged.
	<b>Gloves.</b> Always wear nonslip, heavy-duty protective gloves when operating this product.
	<b>Safety Alert.</b> Precautions that involve your safety.
	<b>Open Flame alert.</b> The power cord is extremely flammable. Keep the splitter away from open flames, sparks, pilot lights, heat, and other potential ignition sources.

## **DANGER**

**DANGER** indicates a hazardous situation which, if not avoided, will result in serious injury and possibly death.

## **WARNING**

**WARNING** indicates a potential hazardous situation which, if not avoided, could result in serious injury or death.

## **CAUTION**

**CAUTION** indicates a hazardous situation which, if not avoided, could result in minor or moderate injury.

## **NOTICE**

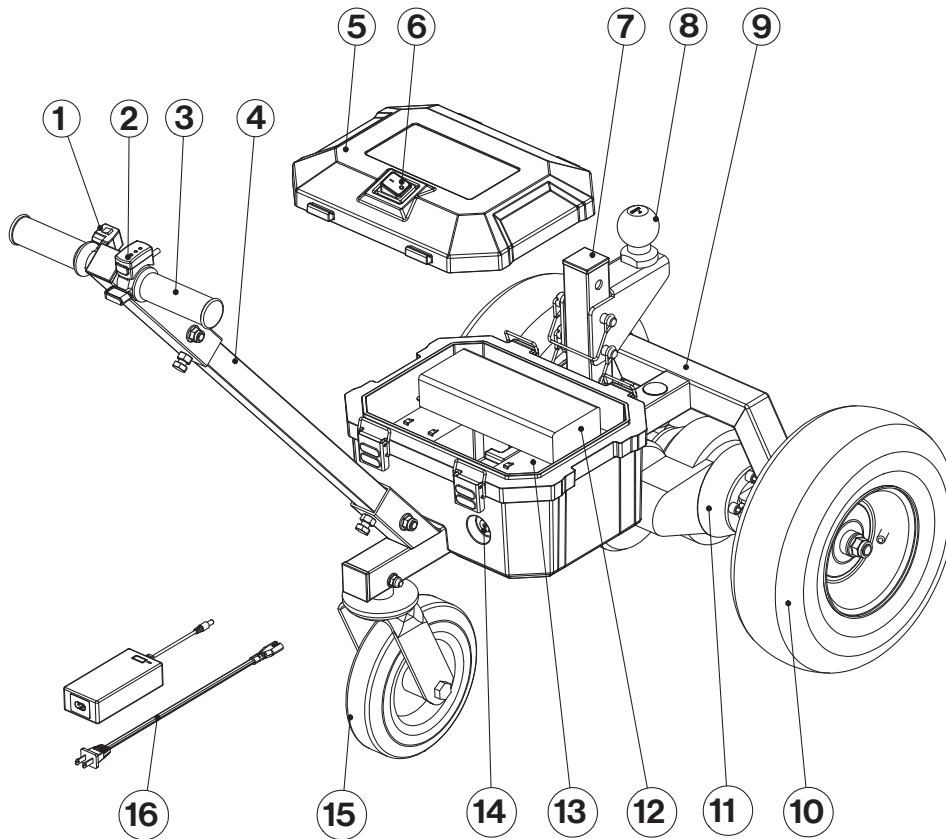
**NOTICE** indicates information considered important, but not hazard-related (e.g., messages relating to property damaged).

## Technical Specifications

<b>SKU#</b>	<b>GUO137</b>
<b>Power Supply</b>	DC24V,7Ah,800W
<b>Speed</b>	0-1.6 MPH (2.5km/h)
<b>Hitch Ball Specifications</b>	2"
<b>Hitch Ball Height</b>	15"-24.3"
<b>Maximum Bearing Capacity</b>	Trailer Weight: 2800 lb (1270 kg) Tongue Weight: 450 lb (204 kg)
<b>Max. Slope</b>	<4° (7%)
<b>Wheel Size (Front / Rear)</b>	8"/13"
<b>Net Weight / Gross Weight</b>	84/97 lb (38/44 kg)
<b>Dimensions</b>	48"x24"x38" (1220x600x965 mm)

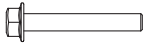
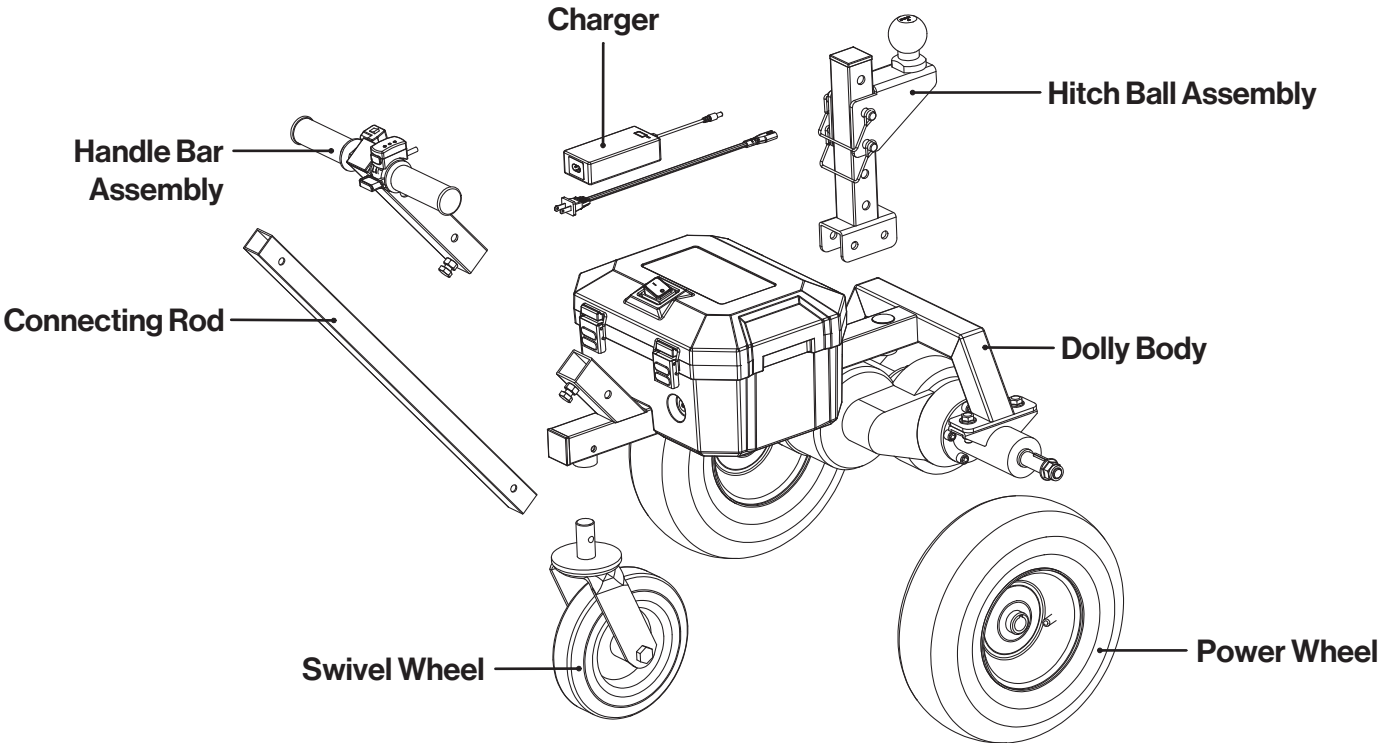
# Main Components

Electric power dolly is compact in structure and convenient in operation. It is used for towing trailers, RVs, etc. equipped with ball head couplings. It has the functions of forward, backward and basic steering. It is intended for movement of trailers over short distances or in compact confined spaces.



1. **Steering switch:** Control the dolly to move "forward" or "backward"
2. **Speed regulating switch:** Adjust the running speed of the dolly
3. **Handle bar assembly:** Install the control switch
4. **Connecting rod:** Connect the handle and the bracket
5. **Battery case:** With battery and controller placed inside
6. **Power switch:** "Turn on" or "Turn off" the power supply of the dolly  
Please turn off the power supply when not in operation
7. **Adjusting lever:** Adjust the upward and downward positions of the ball head
8. **Hitch ball:** Connect the towed vehicle with cover
9. **Bracket assembly:** Fix battery case and rear axle motor
10. **Power wheel:** Transmit the traction
11. **Rear axle motor:** Power supply source
12. **Controller:** A device to preset instructions
13. **Batteries:** Two 12V 7AH lead-acid batteries
14. **DC socket:** Connect the charger
15. **Swivel wheel:** Realize the change of direction .
16. **Charger:** INPUT100-240VAC, OUTPUT: DC28.8V- 2.0A

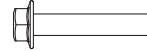
# Parts Overview



**Bolt M8x55 (x1)**



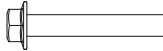
**Domed Plug (x1)**



**Bolt M10x55 (x2)**



**Nut M10 (x4)**



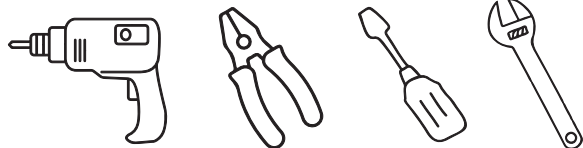
**Bolt M10x65 (x2)**



**Nut M8 (x1)**

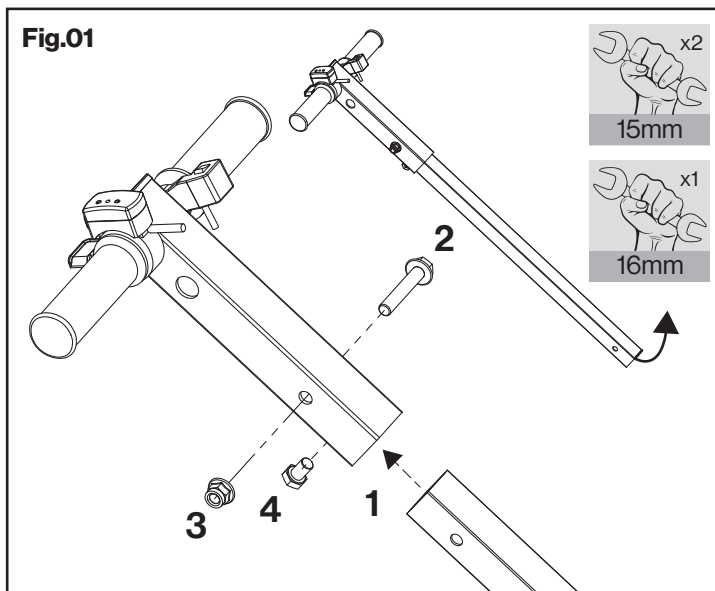
# Assembly

## Recommended tools



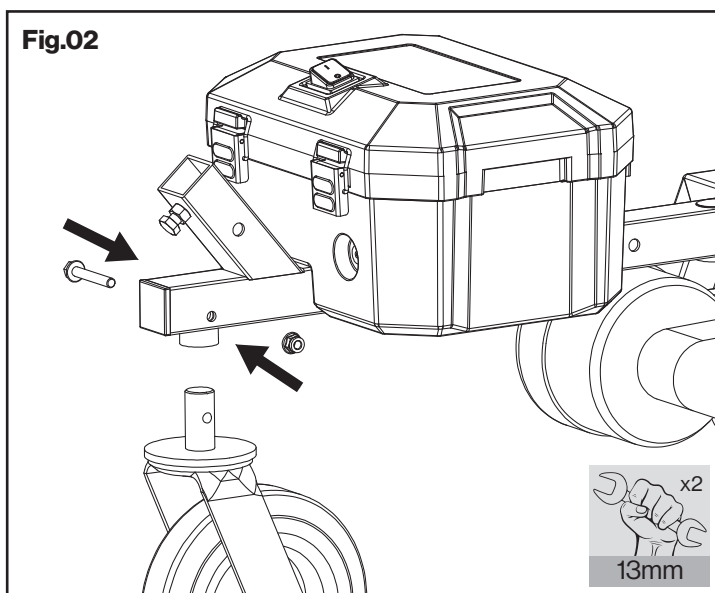
## Step 1- Handle Bar

1. Loosen the M10x16 hexagon bolt on the handle bar assembly, and insert the connecting rod into the handle bar assembly, and thread the wire out from the end of the connecting rod.
2. Insert M10x55 bolt in alignment with the hole.
3. Tighten M10 nut.
4. Tighten the M10x16 hexagon bolt. **(Fig.01)**



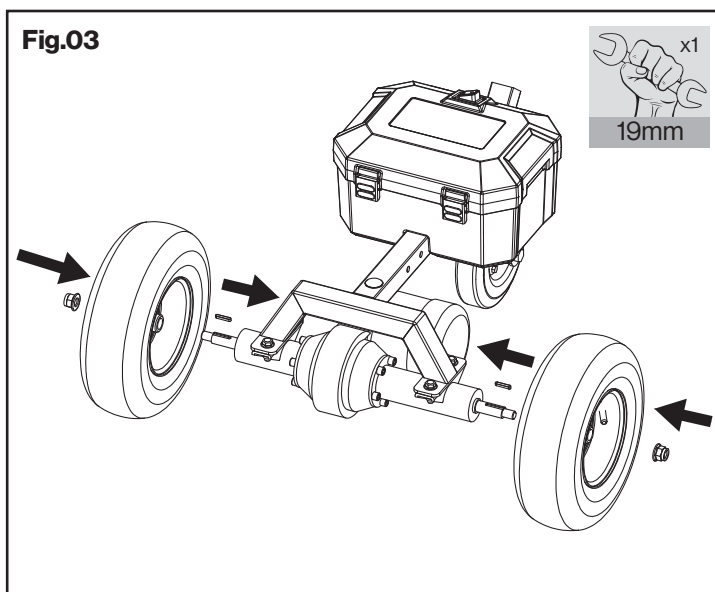
## Step 2-Swivel Wheel

Put the swivel wheel shaft into the force frame, fixed by M8 nut and M8x55 bolt. **(Fig.02)**



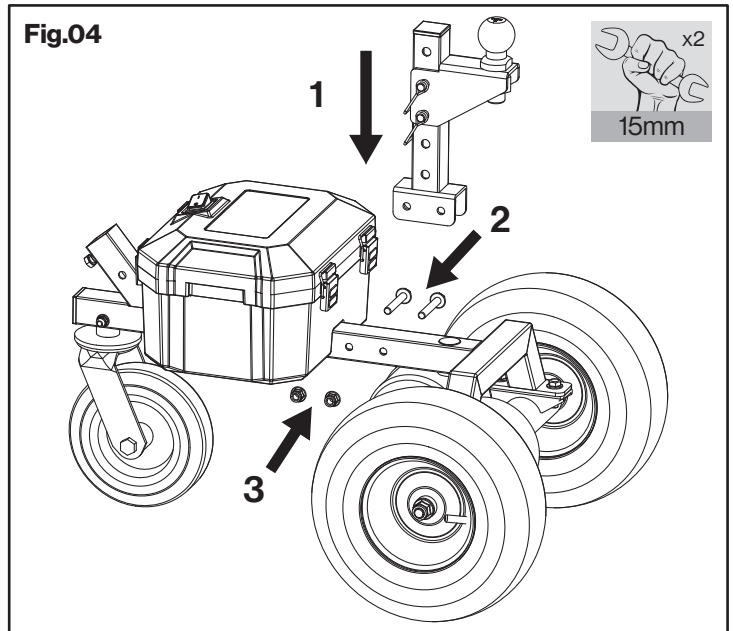
## Step 3- Power Wheel

Install the power wheel on the axle, insert the flat key and fixed by M14 bolts. We suggest to install the power wheels with the inflating inlet at the outside so for easy inflating. **(Fig.03)**



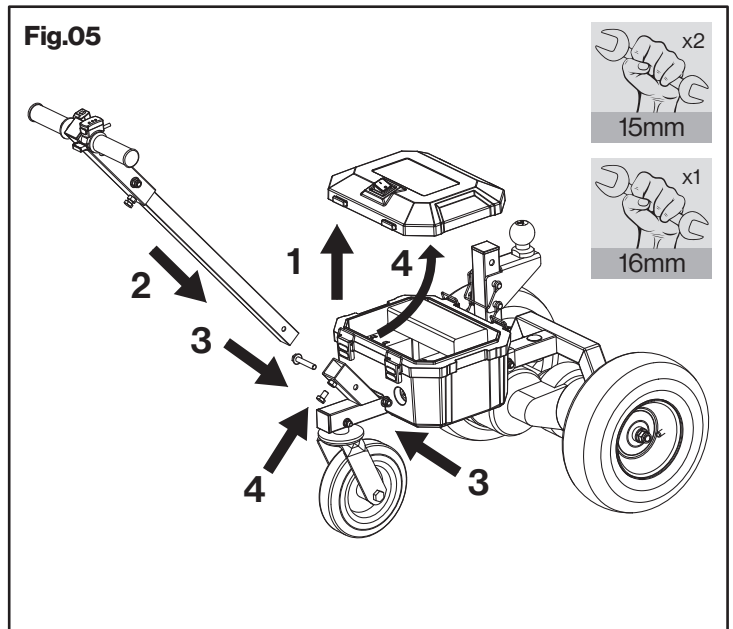
## Step 4- Hitch Ball

Align the trough of the adjusting lever assembly with the frame, fixed by M10 nut and M10x65 bolt. **(Fig.04)**



## Step 5- Connecting Rod

1. Open the battery case cover.
2. Loosen the M10x16 hexagon bolt on the bracket assembly, and then insert the wire out from the end of the connecting rod through the square hole at the front end of the bracket assembly and thread it through the round hole between the bracket assembly and the case body.
3. Align the connecting rod with the hole position of the bracket assembly, insert M10x55 bolt and tighten M10 nut.
4. Lock it with M10x16 bolt. (Reminder: Auxiliary round holes are set on bottom of the bracket assembly to facilitate the observation and crossing of the wires. The wire can be gently hooked or pulled). **(Fig.05)**

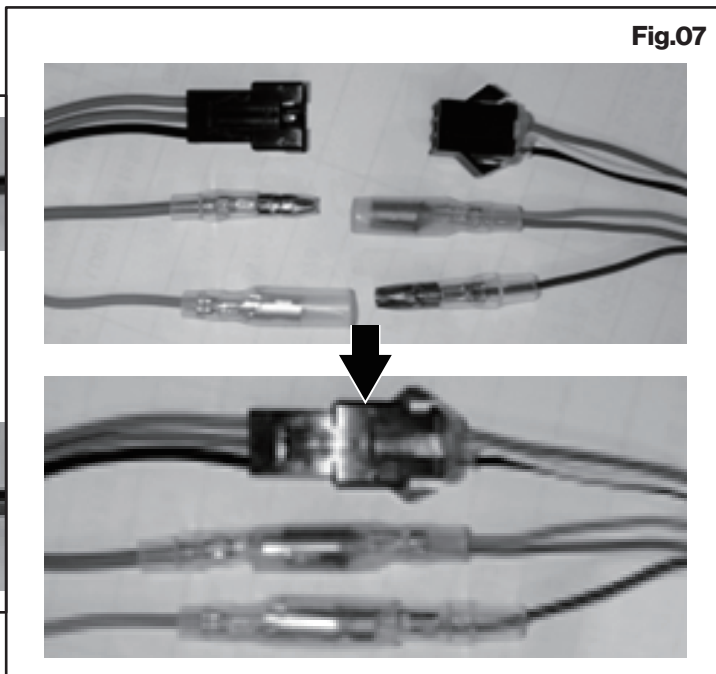
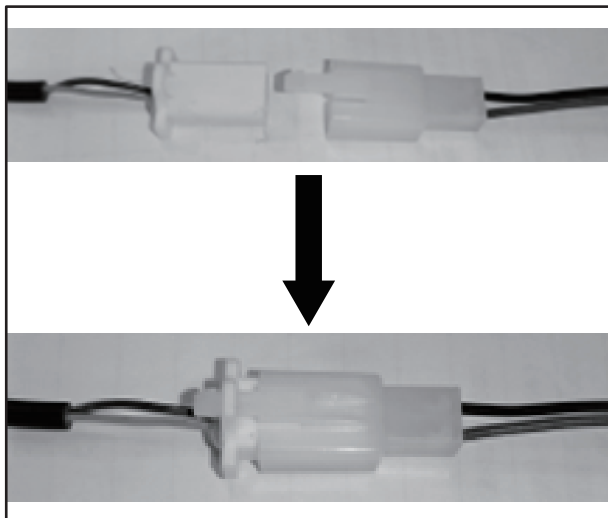


## Step 6- Connection terminals and battery cable

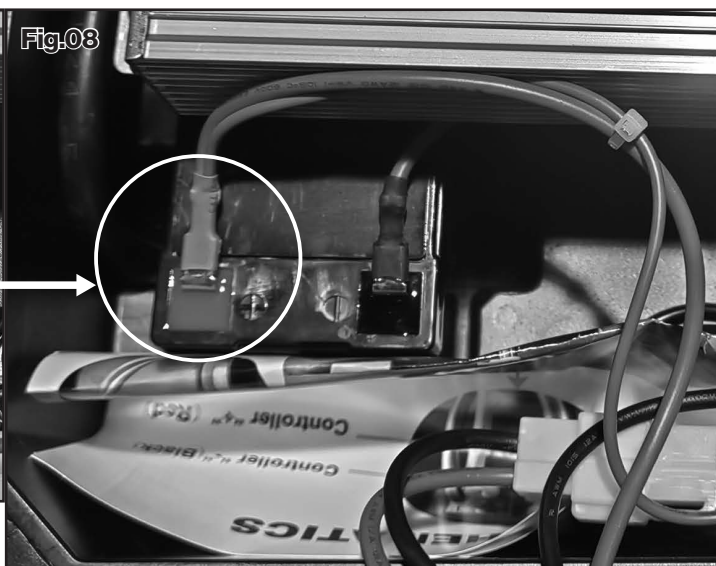
1. Before connecting the terminals and battery cable, carefully read the cable connection diagram placed next to the battery. **(Fig.06)**



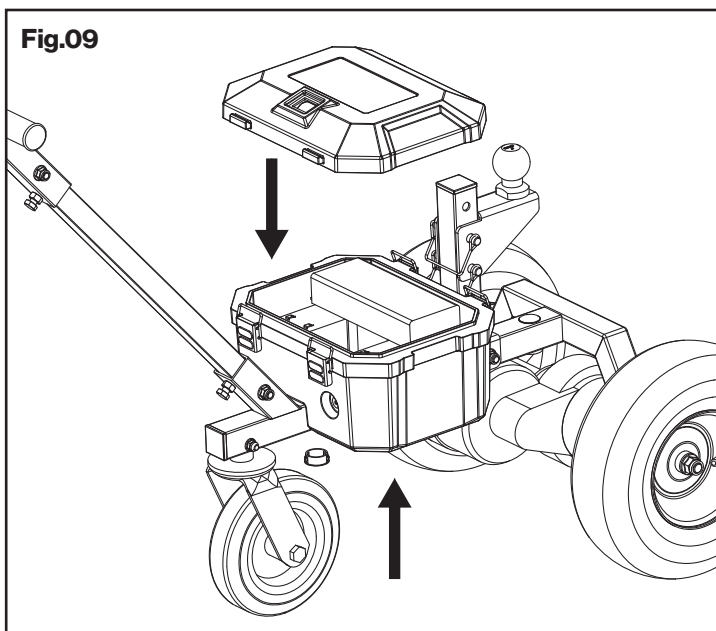
2. Insert the terminals for the speed regulating switch, steering switch and trailer controller tightly. **(Fig.07)**



3. Insert the female end of the red wire into the red male terminal of the battery. **(Fig.08)**



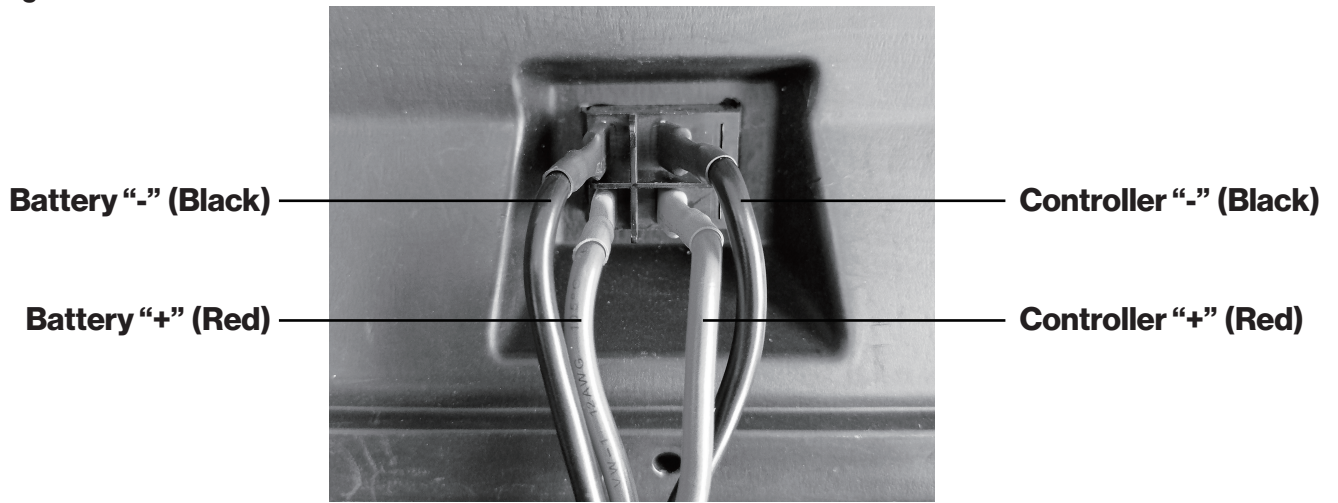
4. After checking that the wiring harness is connected accurately, replace the battery case cover and secure the buckle ;Then Cover the dome plug for sealing, installation finished. **(Fig.09)**



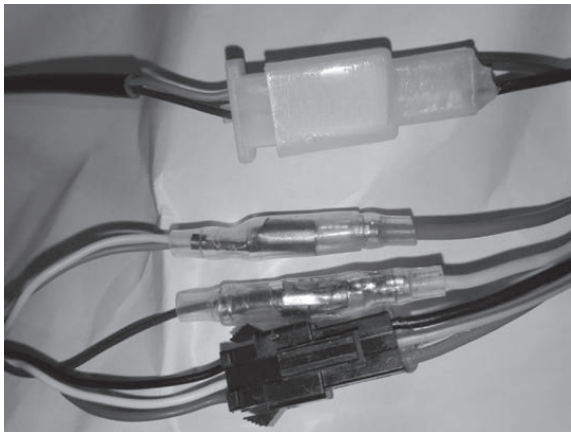
**⚠ CAUTION**

Incorrect power switch cable connection may cause a short-circuit, it may lead battery destroy, fir or physical danger.

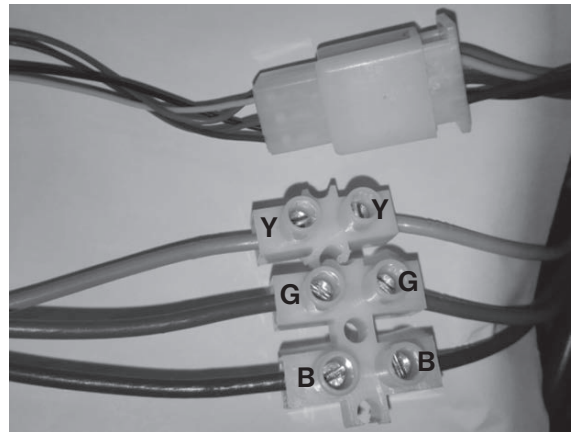
Fig.10



Contol Switch Controller



Motor Connection



# Operation

## Preparation Before Operation

1. Before operation, check that all bolts are fastened tightly, and the hitch ball is secured.
2. Be sure that the tires are free of defects such as cracks and bulges, and the tire pressure is kept at  $30 \pm 2$ psi ( $2.1 \pm 0.1$ kg/cm<sup>2</sup>).

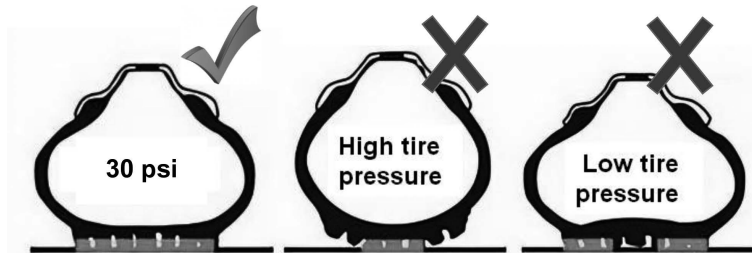


Fig.11

3. Be sure the battery is charged in full, and check whether all switches are operated effectively.
4. Perform no-load test run, to confirm that the Swivel wheel rotates flexibly and entire unit moves forward and backward freely.
5. Be sure the towed trailer weighs less than 2800 lb/1270 kg, and tongue weight is less than 450 lb/204 kg.

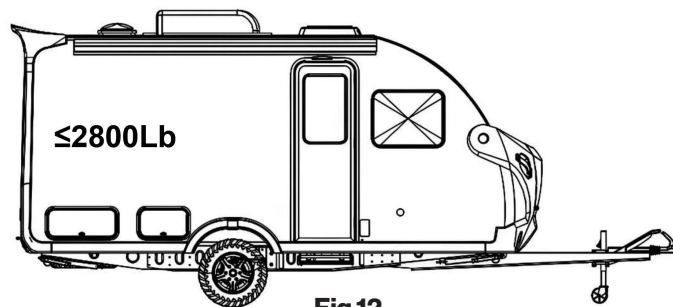


Fig.12

6. The towing road is required to be flat, like concrete, asphalt, etc. At soft surface such as grass and gravel, there will be easier to stuck the tires and make the dolly block.
7. The towing road has a slope of less than 4 degrees. This equipment is not equipped with a brake device, so it cannot be parked on a ramp.

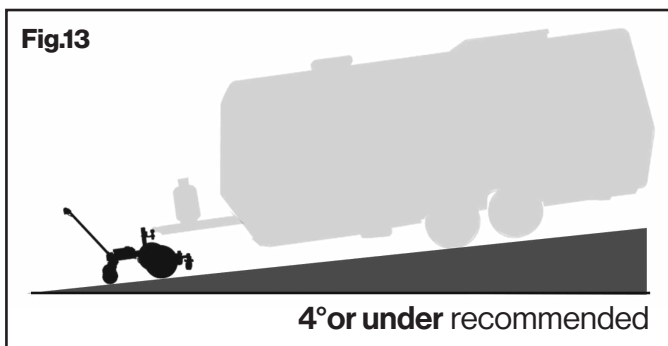


Fig.13

The dolly must always be on the lower end of any incline. DO NOT pull up or push down an incline.

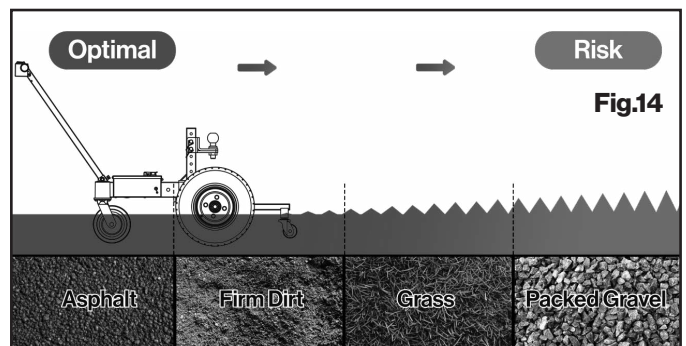


Fig.14

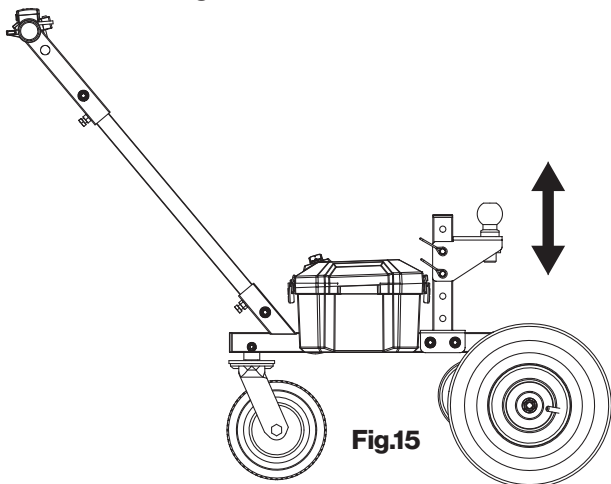
Dolly is better working at flat and firm surface, like concrete, asphalt, etc.. At soft surface such as grass and gravel, there will be easier to stuck the tires and make the dolly block.

## NOTICE

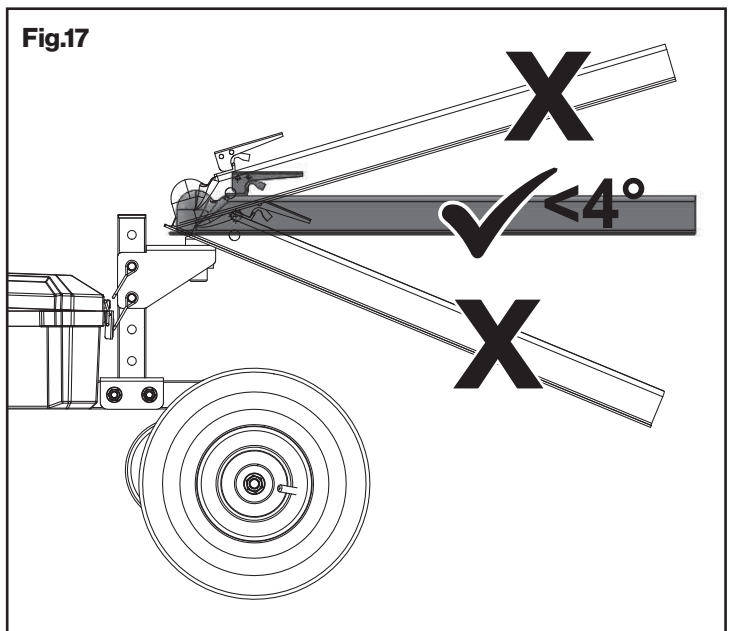
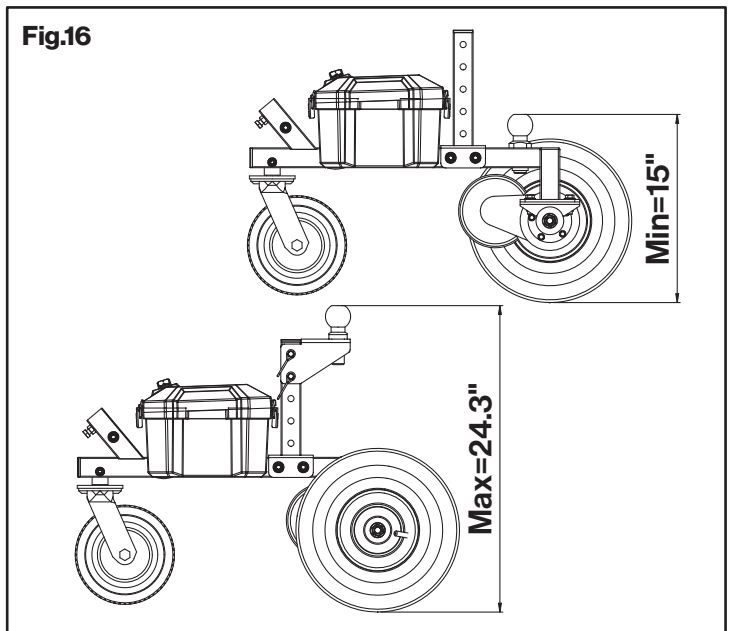
- Grip the handlebar with both hands, and apply pressure while using your own body weight to help stabilize the dolly.
- Avoid losing power or stopping the dolly on slopes to prevent the handlebar from tilting.

## Selection of ball head position

- The height of the dolly's hitch ball can be adjusted. **(Fig.15)** The range of the ball head height is 15"-24.3". **(Fig.16)**

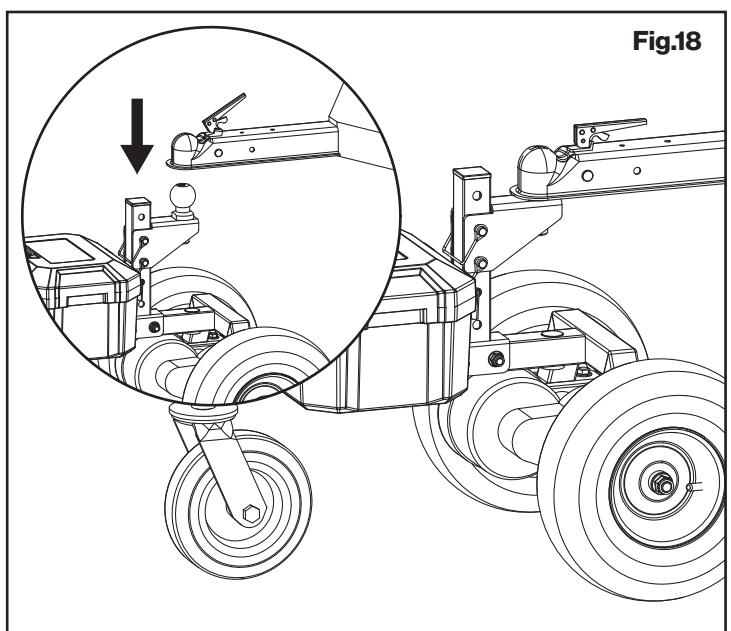


- When installing the trailer, always ensure that the connecting rod is parallel to the ground. Any inclination will affect the traction efficiency and even pose safety hazards. **(Fig.17)**

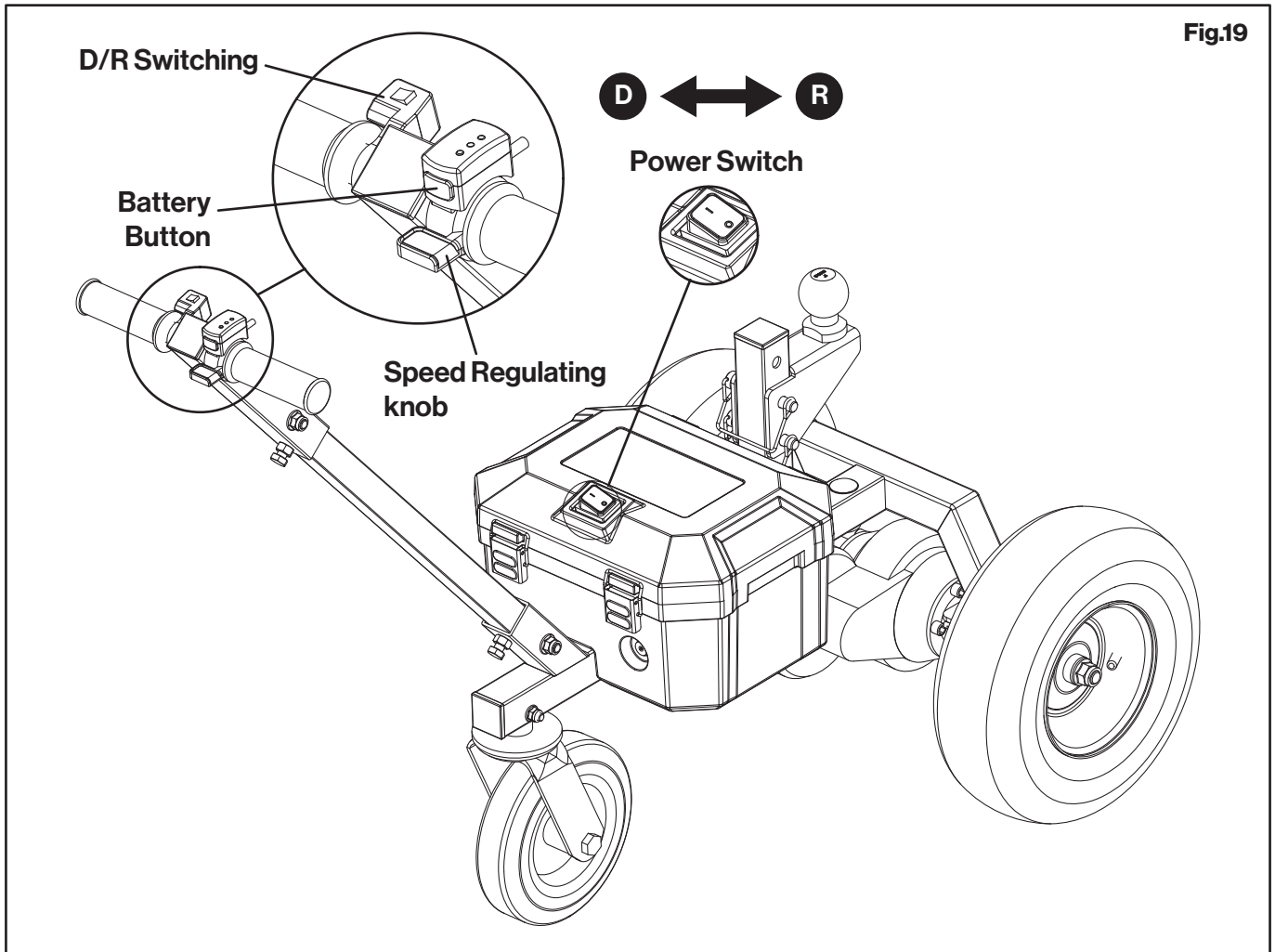


## Towing Procedure

- First, approach the dolly near the trailer's hitch ball cover, and adjust the height of the hitch ball according to the height of the cover, so that the height of the hitch ball is slightly lower than that of the cover. Move the dolly so that the hitch ball is concentric with the Z axis of the cover, and slowly lower the trailer through the elevator, so that the cover is fully engaged with the hitch ball. After confirming the reliable connection between the hitch ball and the cover, lock the safety hook. **(Fig.18)**



2. Switch on the power switch, and press the battery button on the speed regulating switch (the battery indicator lights up). Pull the steering switch to position "D" for dragging, and position "R" for pushing, move forward or backward as the arrow. Then press the speed control knob lightly, and the dolly starts to move. The moving speed can be controlled by the pressing force (0-2.5km/h Variable). **(Fig.19)**



3. Shut down the power switch after use. And park the dolly in the correct position.

**NOTICE**

**PLEASE RECHARGE THE BATTERY WITHN 3 MONTHS OTHERWISE THE LEAD ACID BATTERY MAY BE DESTRIED.**

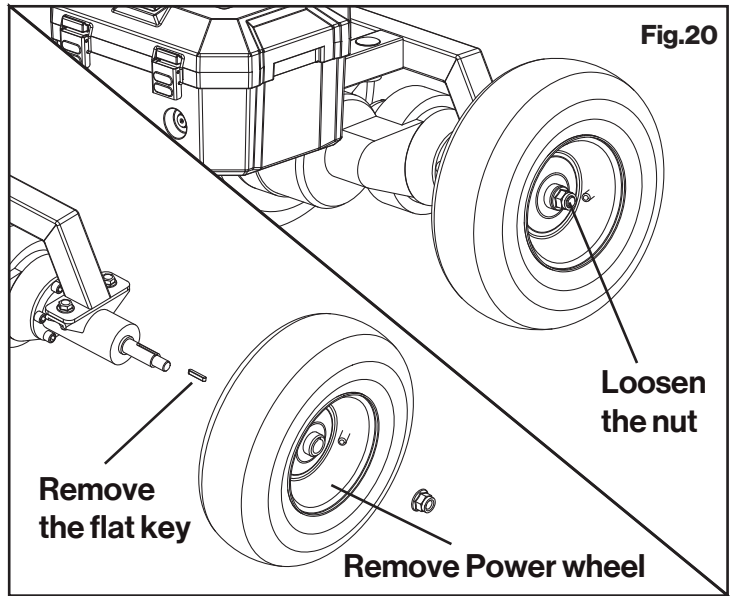
**Overload Protection**

The dolly is equipped with overload protection system, which will shut down the dolly when it detects an overload situation. This will protection is for both user and the product. To prevent the potential risk of damage or destruction of the machine, or injury to the operator. Please do not try to start when the dolly overloaded and shut down, please re-start after the loading weight has been reduced to within the max rated capacity of the product.

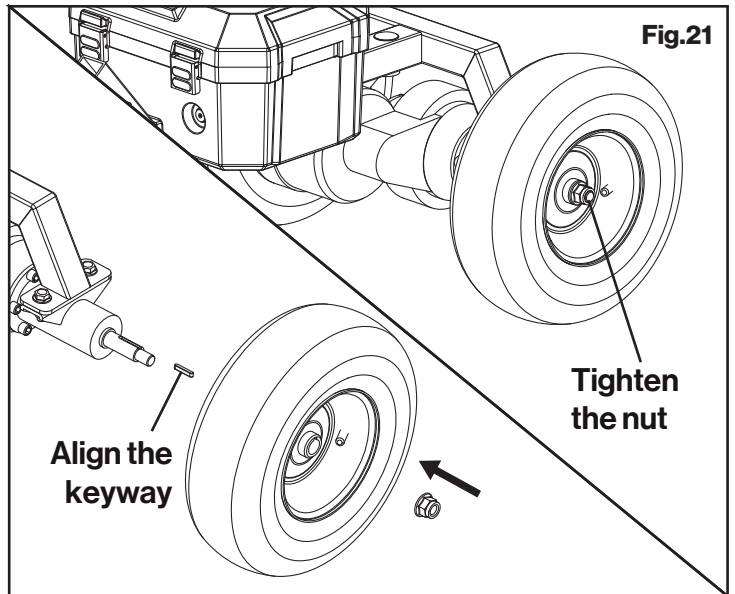
# Maintenance

## Power Wheel Replacement

1. Loosen M14 nut, knock the power wheel off alternately from left and right with a soft hammer, and remove the flat key. **(Fig.20)**

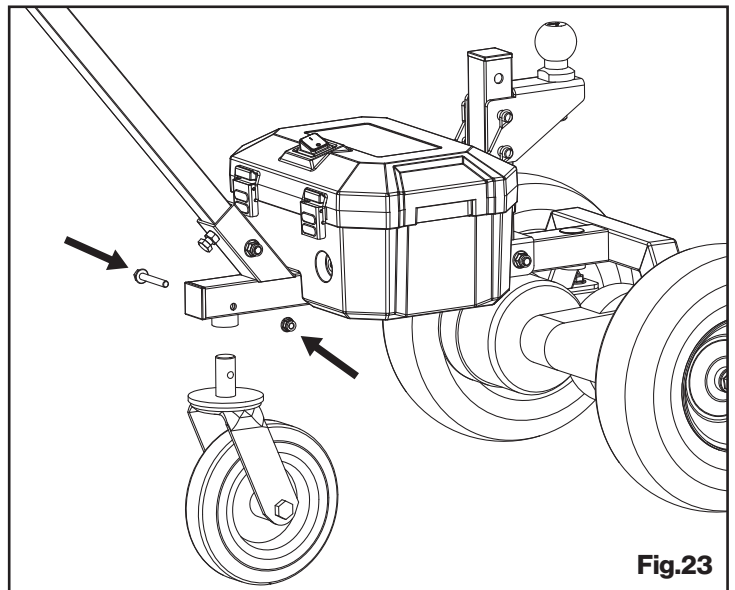
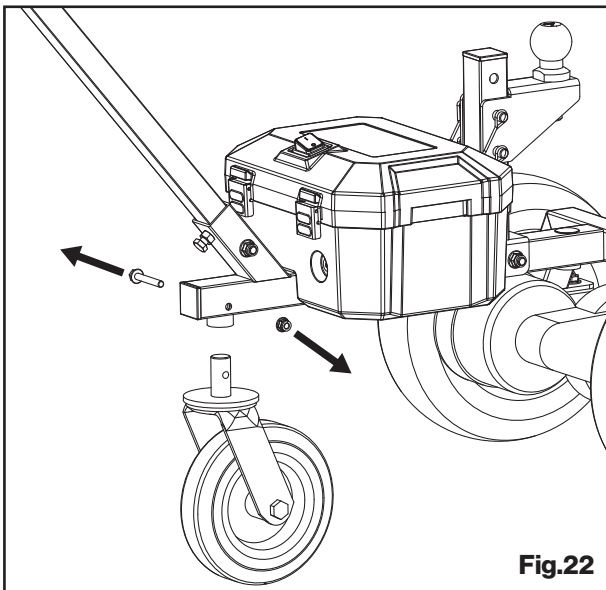


2. Align the keyway surface, knock in the flat key, sleeve the power wheel on the rear axle with the inflation port outwards, and tighten the M14 nut. **(Fig.21)**



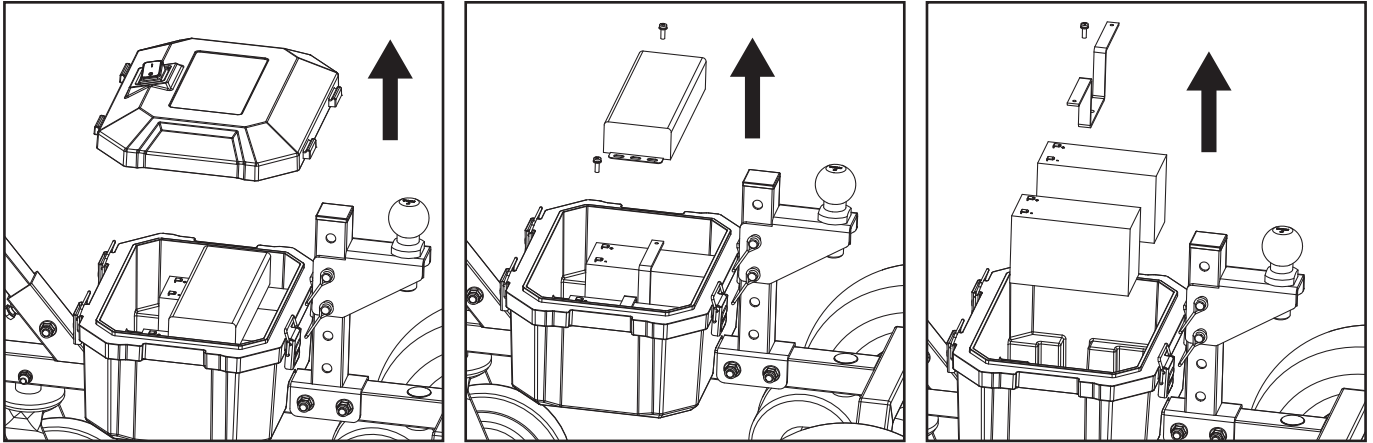
## Swivel Wheel Replacement

1. Loosen M8 nut and M8x55 bolt on the wheel cover. Then remove M8 bolt and nut, and take out the Swivel wheel downwards. **(Fig.22)**
2. Align the fixing shaft of the Swivel wheel with the shaft sleeve in the bracket, insert M8 bolt in alignment with the mounting hole and tighten the M8x55 nut. **(Fig.23)**



## Controller and Battery Replacement

1. Open the battery case cover. Remove all terminals of the controller and the battery , loosen the screws at both ends of the controller to remove the controller, and then remove the screws on the battery holder to take out the battery. **(Fig.24)**



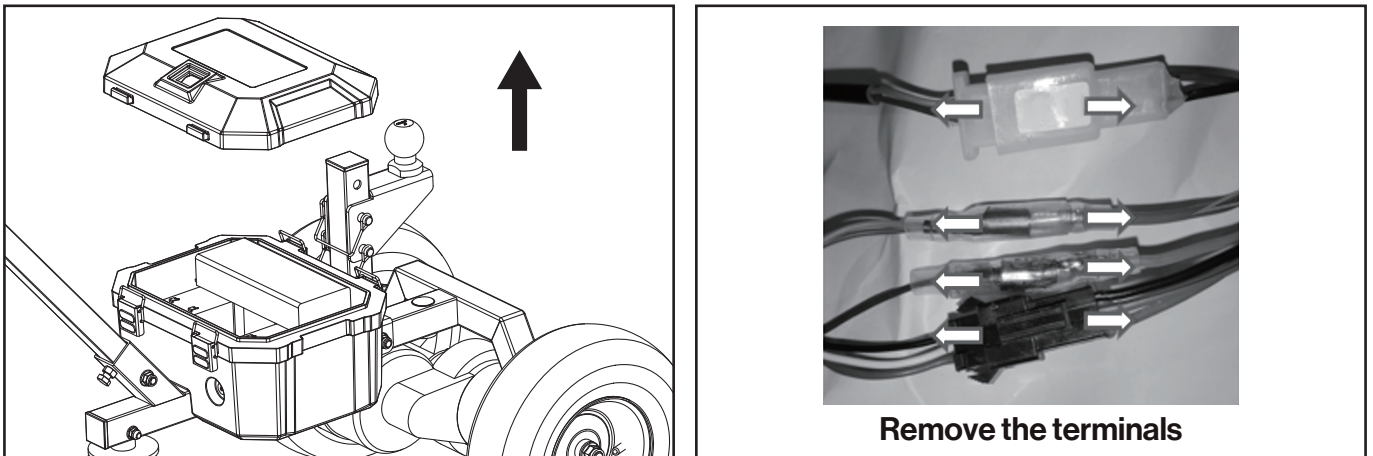
**Fig.24**

2. Install the battery and the controller in turn according to the above reverse steps, and connect the terminals according to the cable connection diagram.

**Note:** Due to the transportation conditions, please buy NPP 12V 7A of the same specification/model locally for replacement of the battery.

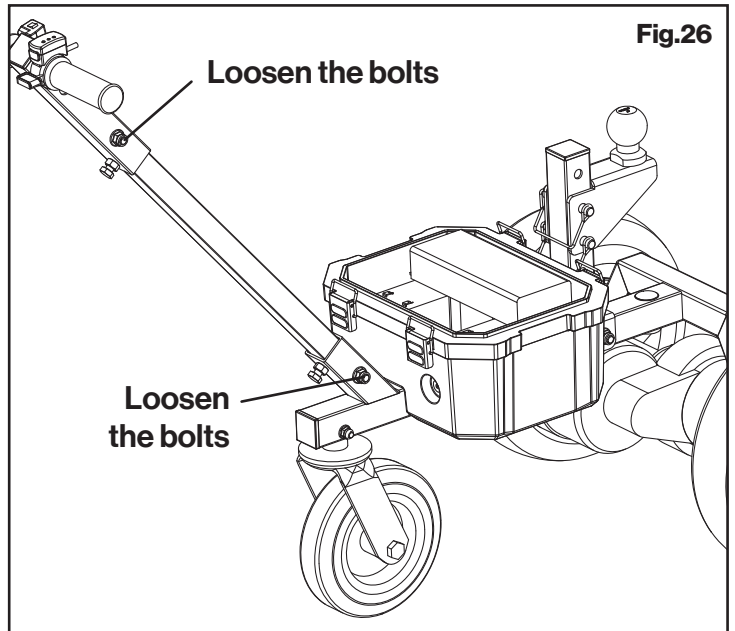
## Steering Switch and Speed Regulating Switch Replacement

1. Open the battery case cover, locate the connecting terminals of the steering switch, the speed regulating switch & the controller according to the cable connection diagram, and Then remove them. **(Fig.25)**

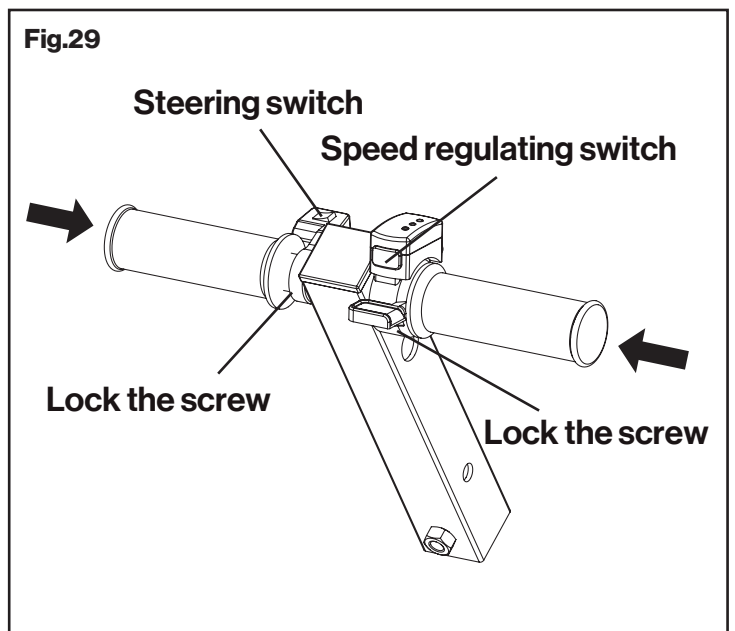
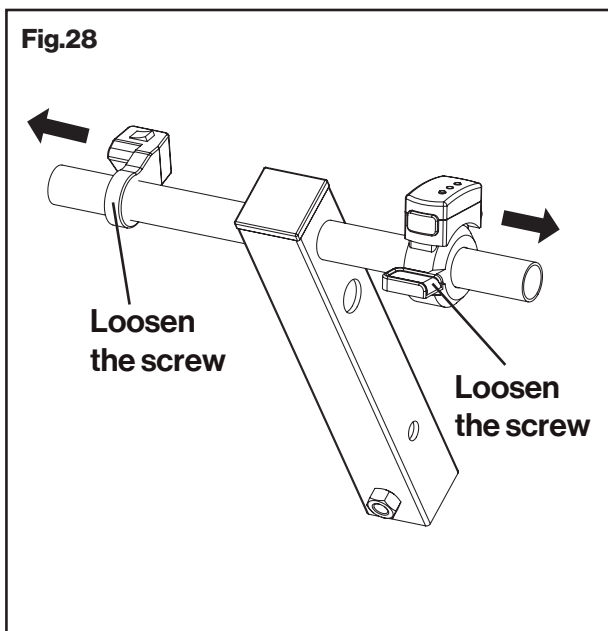
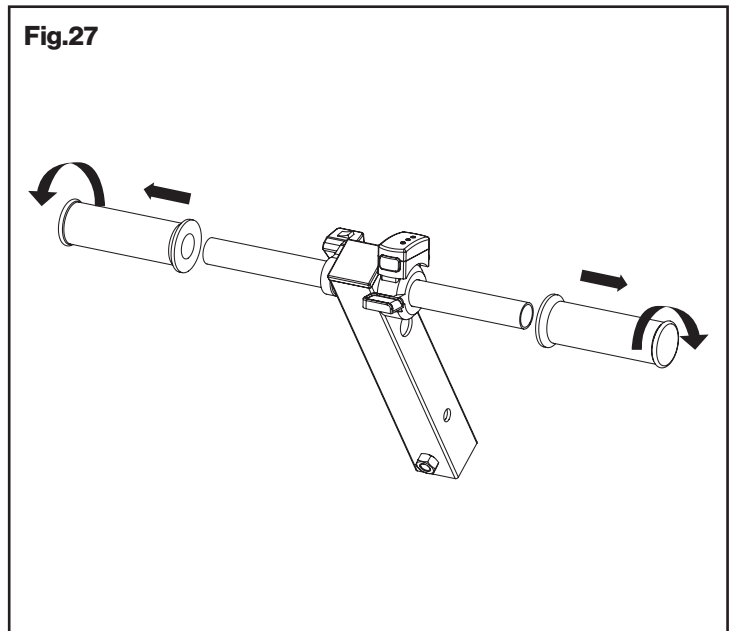


**Fig.25**

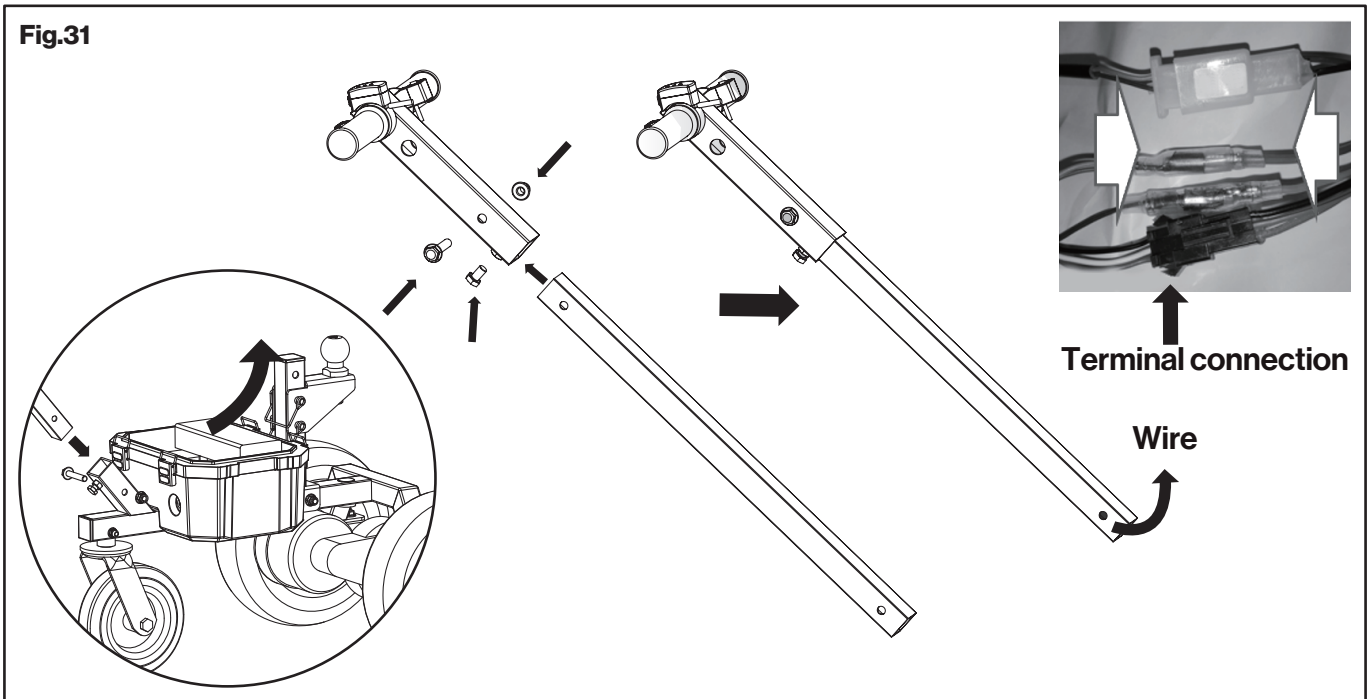
- Loosen the bolts between the handle bar assembly and the connecting rod, and between the connecting rod and the bracket, pull out the wires and remove the handle bar assembly. **(Fig.26)**



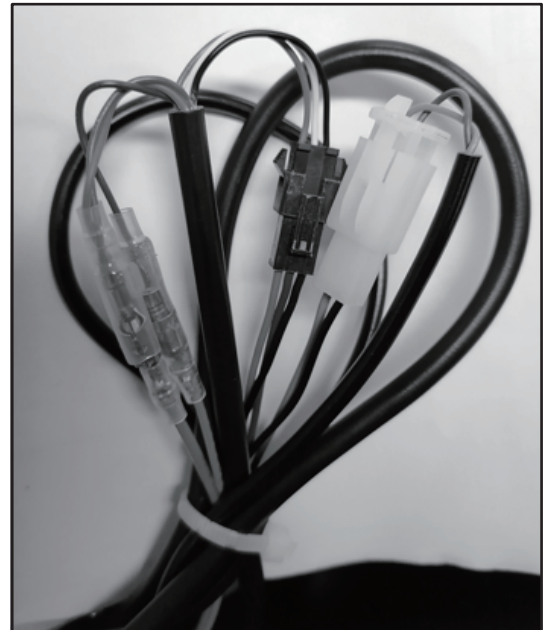
- Rotate the handle sleeve and forcibly pull it out. Since the handle sleeve is prone to hardening when the ambient temperature is low, it is recommended to cover it with hot and wet cotton cloth before pulling it out. **(Fig.27)**
- Loosen the lock screw at the lower side of the steering switch\speed regulating switch, and move the switch out. Be sure not to use too much force, and pay attention to protecting the wires and terminals. **(Fig.28)**
- Put the new steering switch and speed regulating switch on the handle bar and move them to the appropriate position, lock the lower screw and put on the handle sleeve, thread the wires respectively through the round holes of the square pipes on both sides, and pay attention to protecting the wires and terminals. **(Fig.29)**



6. Thread the wire into the connecting rod, and then through the front end of the bracket into the battery case. Assemble the handle bar assembly with the connecting rod, and the connecting rod with the bracket, and insert the wire terminal with the terminal of the controller tightly. **(Fig.30)**



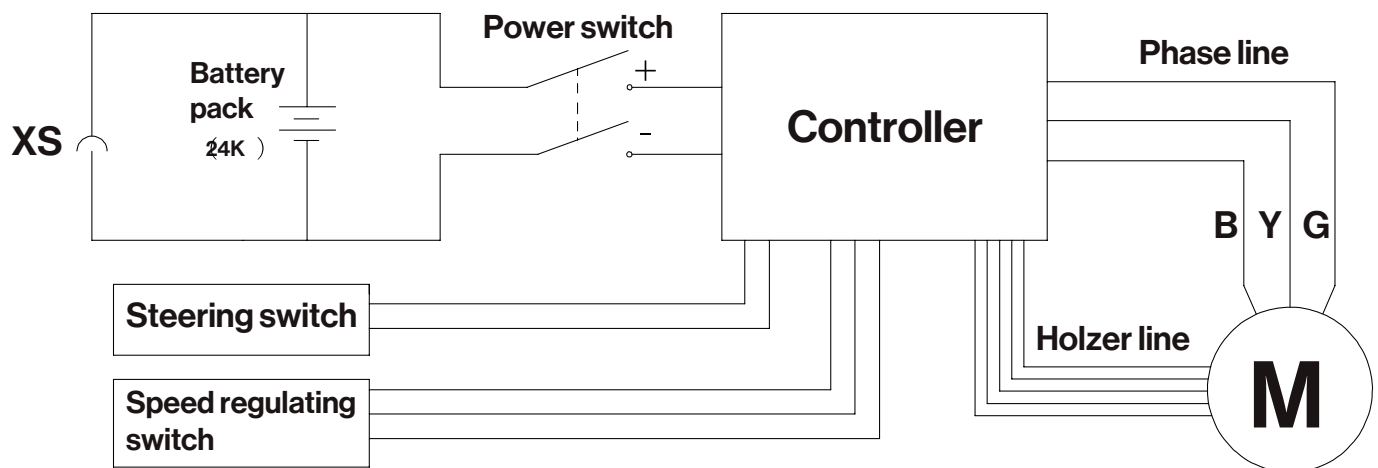
7. Then arrange the excess wires in the battery case, secure them with a strap or zip-tie, and put on the battery case cover. **(Fig.31)**



**Fig.31**

**Note:** Please disconnect the charging plug before the above maintenance operation. Maintenance shall be carried out under the professional guidance of the manufacturer, service agent or similar full-time personnel to avoid danger. Damaged machines, accessories and packaging materials must be treated by classification according to local environmental protection requirements.

## Electrical Schematic Diagram



## Storage

- For storage, the product shall be stored in a cool, dry and dust-free place, to avoid direct sunlight and rain.
- When the unit is not in use for an extended period of time, please open the battery box cover and unplug the positive output cable of the battery pack to ensure that the battery pack is physically disconnected to reduce selfdischarge and extend battery life.
- Charge the battery pack at least every 2-3 months during storage.
- During the transportation, loading and unloading of the product, it is prohibited to cast, drop, throw, trample and perform other barbaric operations on the product.

## Warranty

Twelve (12) months for workmanship of the product, except for wearing parts. Warranty period starts from the product purchase date. Warranty covers material quality and workmanship only. Warranty does not cover product for issues caused by improper usage or any operation not in accordance with the specifications of this manual. Any modification or tampering with the product in any way voids the warranty.

### Warranty Exclusions

- **Normal Wear and Tear:** Includes coating, plating, natural fading, and material deterioration (e.g., resin).
- **Improper Usage:** Issues from overloading, improper operations, or failure to follow manual instructions.
- **Environmental Damage:** Damage caused by external factors like soot, chemicals, acid rain, severe weather (e.g., floods, earthquakes), and environmental particles.

#### Please note the warranty does not cover:

- Wear parts listed in the Parts Explosion.
- Damage caused by misuse, including overloading the machine, improper maintenance, or unauthorized modifications.
- Incidents of improper storage, such as leaving the dolly exposed to extreme weather conditions without adequate protection.

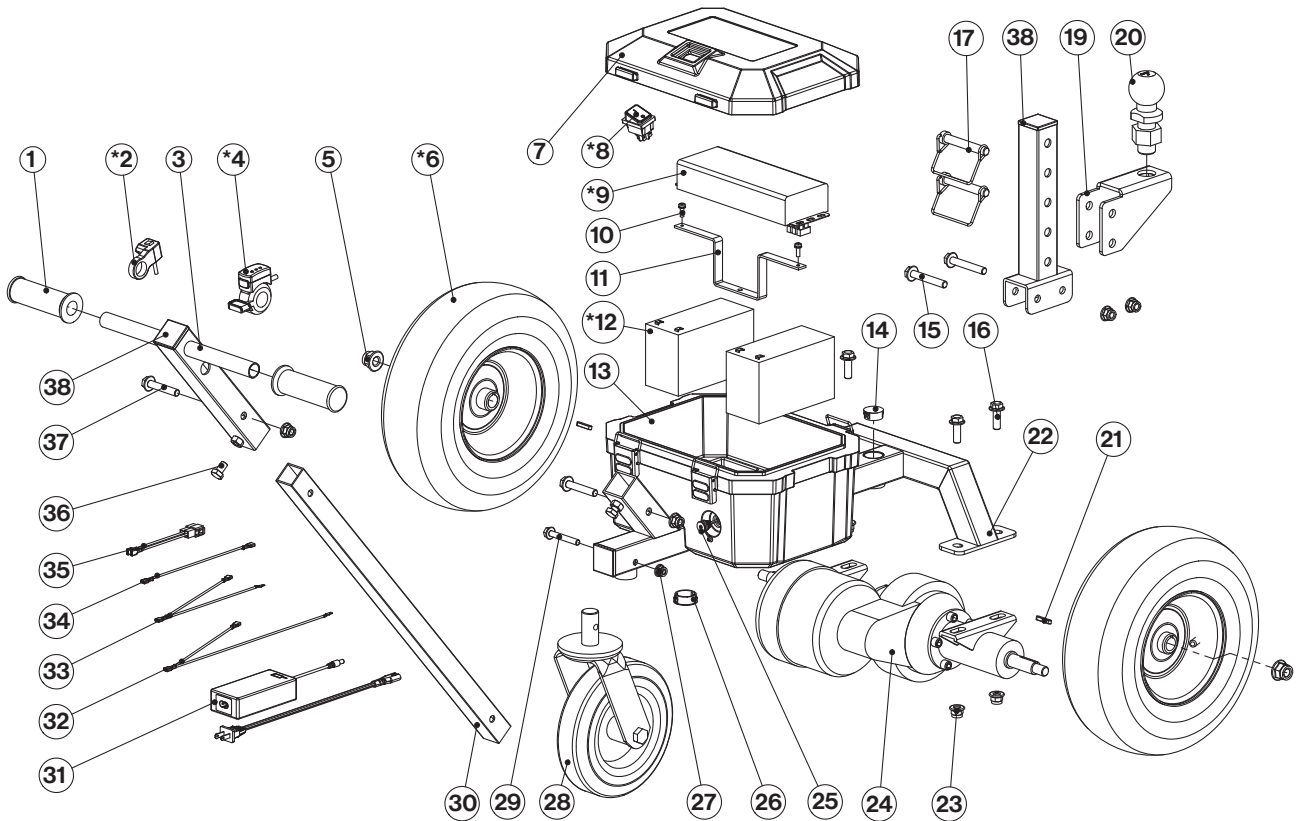
#### To make a warranty claim, ensure the following steps:

- Provide proof of purchase (e.g., receipt or order confirmation).
- Ensure the product has been used according to the operating instructions in the manual.
- Contact our Customer Support Team with details about the issue and supporting documentation.

## Troubleshooting

Issue	Possible Cause	Solution
<b>Power dolly do not works</b>	Power shut down	<ol style="list-style-type: none"> <li>1. Check the battery status make sure it in full .</li> <li>2. Check the power switch in power on status.</li> <li>3. Check the connect cable without loose.</li> </ol>
<b>Power dolly stop during working</b>	<ol style="list-style-type: none"> <li>1. Batteries in low</li> <li>2. Power dolly overloaded</li> </ol>	<ol style="list-style-type: none"> <li>1. Recharge the power dolly in full.</li> <li>2. Reduce the loading weight with the capacity and re-start.</li> </ol>
<b>Drive wheel slip in place</b>	<ol style="list-style-type: none"> <li>1. Ball head is underloaded, resulting in insufficient friction.</li> <li>2. Tire pressure is either too high or too low, affecting the tire's contact area.</li> <li>3. Ground is slippery, uneven, or bumpy.</li> </ol>	<ol style="list-style-type: none"> <li>1. Add weight near the ball joint to increase the friction between the tire and the ground.</li> <li>2. Maintain tire pressure at <math>30 \pm 2</math> psi to ensure a larger contact area between the tire and the ground.</li> <li>3. Keep the ground dry and level.</li> </ol>
<b>Battery cannot be charged</b>	<ol style="list-style-type: none"> <li>1. Charger plug is not properly connected.</li> <li>2. DC socket is not functioning.</li> <li>3. Battery is faulty.</li> </ol>	<ol style="list-style-type: none"> <li>1. Check and reconnect the charger plug.</li> <li>2. Contact the manufacturer for a replacement DC socket.</li> <li>3. Check the battery and reach out to the manufacturer for a replacement.</li> </ol>

# Parts Explosion



Part No.	Description	Q'ty	Part No.	Description	Q'ty
1	Handle sleeve	2	20	Hitch ball	1
*2	Steering switch	1	21	Ordinary flat key 5x5x28	2
3	Handle bar assembly	1	22	Bracket assembly	1
*4	Speed regulating switch	1	23	Hexagon flange lock nut M10	8
5	Hexagon flange nut M14x1.5	2	24	Rear axle 24V-800W	1
*6	13-inch power wheel	2	25	DC socket	1
7	Battery case cover	1	26	Dome plug $\Phi$ 30	1
*8	Power switch	1	27	Hexagon flange lock nut M8	1
*9	Trailer controller 24V 800W	1	28	Swivel wheel, 8-in	1
10	Combined screw M5x16	5	29	Hexagon flange bolt M8x55	1
11	Holder	1	30	Connecting rod	1
*12	Battery 12V 7Ah	2	31	Charger 24V 2A	1
13	Case body	1	32	Wire harness 3	1
14	Dome plug $\Phi$ 26	1	33	Wire harness 4	1
15	Hexagon flange bolt M10x65	2	34	Wire harness 1	1
16	Hexagon flange bolt M10x30	4	35	Wire harness 2	1
17	Square Pin	2	36	Hexagonal-head bolt M10x16	1
18	Adjusting lever assembly	1	37	Hexagon flange bolt M10x55	2
19	Hitch ball installation assembly	1	38	Square pipe plug 40*40	3

**Note: "\*" is the wear part of the product.**





Thank you for supporting our brand!

superhandyus.com



Great Circle USA  
Support Line: 1-866-493-0524  
help@greatcircleus.com  
www.superhandyus.com



Follow us on social media  
**@SuperHandy**