

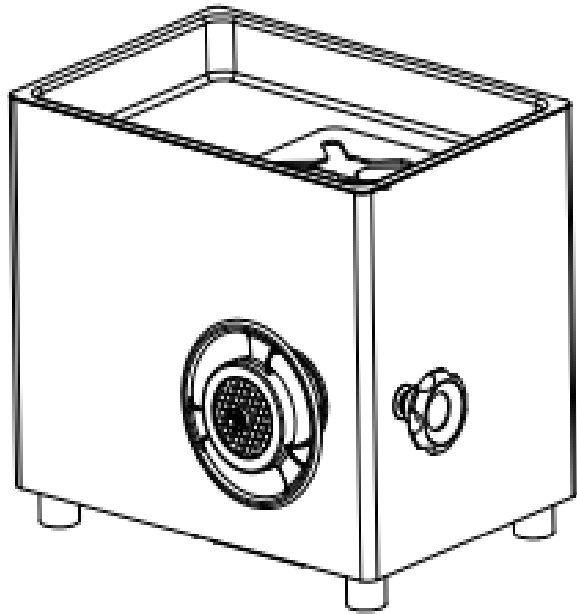

#22 COMMERCIAL MEAT MINCER

USER MANUAL

Model#: 1A-CG122



INTRODUCTION

- Thanks for using this style stainless steel meat grinder. The appliance can be operated easier and safer than other similar appliance.
- This instruction manual gives the customer all the necessary information about the appliance and the manufacturing standards applied, as well as all instructions for use and maintenance so that the appliance can be used correctly maintaining its efficiency in time.
- This instruction manual is for the end user and for service personnel
- In order to ensure the stability and safety of the production, the appliance has passed through dielectric voltage withstand test, earth resistance test, power leakage test and normal temperature test before leaving factory.

IMPORTANT SAFEGUARDS

When using electrical appliances, always follow basic safety precautions including the following:

1. **READ ALL NOPERATING INSTRUCTIONS AND PRODUCT SAFETY LABELS!**
2. **CHECK FOR DAMAGED PARTS:** Before using the Grinder, checks that all parts are operating properly and performing the intended functions. Check for alignment of moving parts, binding of moving parts, mounting and any other conditions that may affect the operation. If any parts, the **Power Cord** or the **Grinder** are damaged, call the Customer Service number shown in this manual.
3. Always unplug power cord from outlet when not in use, before putting on or taking off parts or accessories, and before cleaning. **After unplugging the unit, turn power switch ON, then OFF to ensure that all power has been discharged from the grinder.**
4. This appliance is NOT intended for use by children or by persons (including children) with reduced physical, sensory or mental capabilities, or lack of experience and knowledge. This appliance is not to be used by children!
5. **NVEER LEAVE GRINDER UNATTENDED WHILE IT IS RUNNING!**
6. **ALWAYS USE THE PROVIDED STOMPER, NEVER FEED FOOD BY HAND. KEEP FINGERS CLEAR OF THE AUGER AND CUTTING BLADES AT ALL TIMES .NEVER REACH INTO THE GRINDER,** doing so may cause serious injury
7. **Always keep the tray guard in place while operating(Note: tray guard is installed on#22,#32 models only)**
8. **AVOID** contact with moving parts. **NEVER USE YOUR FINGERS TO SCRAPE FOOD AWAY FROM THE CUTTING BLADE WHILE IT IS IN OPERATION.** While the **Grinder** is in operation. **SEVERE INJURY MAY RESULT.**
9. **Wait until all moving parts have stopped and turn off power before removing any part from the grinder or before switching the grinder in reverse**
10. **TIE BACK** loose hair, clothing, or any loose object and roll up long sleeves before operating the **Grinder.**
11. **REMOVE** ties, rings, watches, bracelets, or other jewelry before operating the **Grinder.**
12. **DO NOT** operates **Grinder,** or any other electrical equipment, with a damaged cord or plug or after the unit malfunctions. **DO NOT ATTEMPT TO REPLACE THE CORD.** Call Customer Service to arrange to return the grinder for examination, repair, or adjustment
13. **DO NOT** use outdoors, this product is intended for **INDOOR USE ONLY**
14. **DO NOT** let cord hang over the edge of a table or counter, come into contact with sharp edges, or touch hot surfaces.
15. **DO NOT** lest cord become kinked, trapped under unit or let it wind around the grinder
16. **DO NOT** pull the power cord to disconnect
17. **DO NOT USE WITH EXTENSION CORD.** Always plug directly into a grounded wall
18. **Telegator** uses a grounded, three prong plug (hot, neutral and ground), that should be



- connected directly to a grounded 220 Volt, 50 Hz three prong grounded wall outlet receptacle. Grounded plugs are used on metal---encased electric appliances in order to provide protection from an electric shock. **DO NOT** change or alter the plug in any way. **NEVER** break off a grounding prong from a 3---conductor plug. Doing so voids the warranty and can result in electric shock.
19. Place the grinder on a firm and stable surface. Ensure that the grinder is not placed near the edge of the worktop, where it can be easily pushed off or fall.
 20. **The Gear Housing and the Motor Cover may become HOT during operation.** This is normal. **DO NOT TOUCH** these parts while operating.
 21. **DO NOT** attempt to operate the **Grinder** if the **Grinder, Motor and Gear Box are cold. Grinder, Motor and Gear Box** temperature should be at least 45°F (7°C) before beginning.
 22. To reduce the risk of unintentional starting, check that the control is OFF before plugging the cord into wall outlet. To disconnect, turn the control to OFF, then remove plug from wall outlet.
 23. **DO NOT** operate your grinder under a wall cabinet. When storing, always unplug the unit from the electrical outlet. Not doing so could create a risk of fire, especially if the appliance touches the walls of the garage or the door touches the unit as it closes.
 24. **NEVER** plug the grinder in where water may flood the area.
 25. To protect against risk of electrical shock, **DO NOT** submerge the grinder in water or other liquids. Be sure the grinder is disconnected from the power source before cleaning. **NEVER** rinse the **Grinder Motor** under running water, only use a moist cloth to clean the **Grinder Motor Unit.**
 26. **DO NOT** operate grinder with wet hands or while standing on a wet floor.
 27. The use of attachments or parts not specifically recommended or sold by the manufacturer for this grinder will void the warranty and may cause fire, electric shock or injury
 28. **HAND WASH ALL PARTS! DO NOT USE DISHWASHER.** Never put the unit near a hot burner, in an oven, or in a dishwasher.
 29. **NEVER** use abrasive cleaning agents or abrasive cloths when cleaning the grinder.
 30. **DO NOT** use the grinder for other than intended use.
 31. **DO NOT RUN Grinder without meat in the Grinder Head.** Severe damage to the **Head and Auger** may occur.
 32. Never turn on and run the meat grinder for more than 10 seconds dry with no meat inside the machine. The friction between the auger and grinder head will result with high heat causing the meat to stick to the inside of the grinder assembly. **NEVER OPERATE DRY.** Damage from dry operation will void the warranty.
 33. Be sure the **Grinder** is on a stable work surface. Be sure all the **Grinder Feet** are stable.
 34. **DO NOT** attempt to grind bones, nuts or other hard items.
 35. **WEAR EYE PROTECTION.** Wear safety glasses. Everyday eye glasses are not safety glasses. Safety glasses conform to ANSI Z87.1 requirements. Note: approved safety glasses have Z87 printed or stamped on them.
 36. The Manufacturer disclaims any responsibility in the case of improper use of **Grinder.** Improper use of the **Grinder** voids the warranty.
 37. **DO NOT** use **Grinder** while under influence of drugs or alcohol.

SAVE THESE INSTRUCTIONS

Refer to them every time you operate or disassemble this product.

IMPORTANT PRODUCT FEATURES YOU SHOULD KNOW

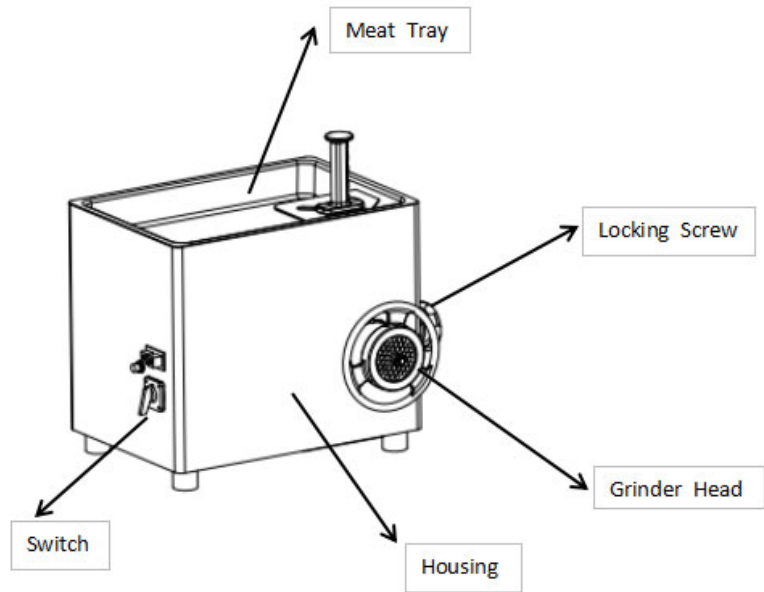

IMPORTANT NOTICE: DO NOT REMOVE WARNING LABELS FROM THE GRINDER!
 Doing so will void the product warranty and may result in serious personal injury.

GETTING TO KNOW YOUR CARNIVORE MEAT GRINDER

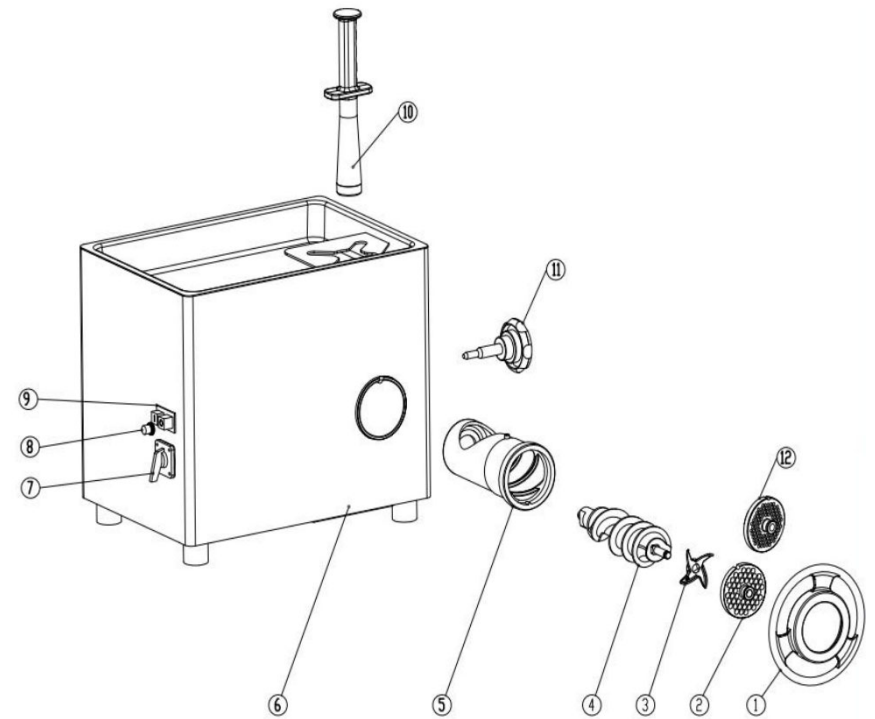

Part List

Part No.	Part Description	Part No.	Part Description
1	Front Ring Nut	7	Reverse Switch
2	10mm Grinder Plate	8	Fuse Protection
3	Grinder Knife	9	ON/OFF Switch
4	Grinder Auger	10	Meat Stomper
5	Grinder Head	11	Locking Knob
6	Housing	12	4.5mm Grinder Plate

ASSEMBLING YOUR CARNIVORE MEAT GRINDER

IMPORTANT: BEFORE ASSEMBLING, MAKE SURE THE GRINDER IS NOT PLUGGED IN.

1. Loosen the **Black Grinder Head Locking Knob** until the threads are not exposed inside the **Motor Housing** opening and insert the **Grinder Head** into the **Motor Housing** with the **Feed Chute** facing straight up. Turn clockwise until the **slot** on the top of the **Grinder Head** aligns with the **Pin** inside the **Motor Housing**. Be sure the **Head** is seated fully into the **Motor Housing** (Figure 1). Tighten the **Grinder Head Locking Knob** to lock the **Grinder Head** into place. (Figure2)
2. Insert the **Auger** by aligning the **Auger Spline** with the **Drive Shaft** of the **Grinder**. Slightly turn the auger clockwise until seats into gear housing. (Figure 3).
3. Place the **Cutting Knife** onto the square portion of the **Auger Pin**. (Figure 4). Note that the **Cutting Knife** is a **ONE---WAY---FIT** design that ensures that the flat side of the blade edges will face outward.
4. Place the **Grinder Plate** onto the **Auger Pin** and align the slotted notch in the **Grinder Plate** with the bottom notch in the **Grinder Head** opening. **NOTE:** The cutting plate will only fit one way and will protrude approx. 1/8" out of the grinder head) *NOTE: IT IS RECOMMENDED TO ALWAYS USE THE COARSE (10mm) PLATE FOR THE FIRST GRIND. (Figure 5).
5. **Attach Front Head Ring Nut and turn the Front Ring Nut clockwise until it is snug against the Grinder Plate.** (Figure 6).
6. **Place the neck of the Meat Tray into the Grinder Feed Chute Opening and press down until secure.** (Figure7)

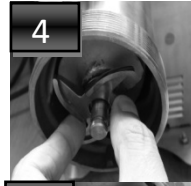
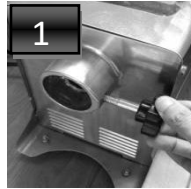

unit, Meat becomes a lubricant when passing through the grinder, if you run out of meat, turn the grinder off immediately

CLEANING, MAINTENANCE & STORAGE

CLEANING INSTRUCTIONS

IMPORTANT: BEFORE CLEANING MAKE SURE THE POWER IS TURNED OFF AND THE UNIT IS UNPLUGGED. Disassemble the Grinder Head and wash parts that come in contact with meat thoroughly in hot soapy water, taking particular care to remove all grease and oil from surfaces. Rinse and dry all parts thoroughly before re---assembling.

1. Wash all parts that have come in contact with meat in hot soapy water. BE SURE TO CLEAN IMMEDIATELY AFTER USE. **DO NOT IMMERSE THE MOTOR IN WATER OR OTHER LIQUIDS!**
2. Rinse the **Grinder** parts with clear hot water, and then dry them IMMEDIATELY.
3. Fully lubricate the **Head, Auger, Plates** and the **Knife** with a food-grade silicone spray before and after each use.
4. Clean the **Housing** with a damp towel and wipe dry. **DO NOT IMMERSE THE MOTOR IN WATER OR OTHER LIQUIDS!**

IMPORTANT: Any metal parts must be coated with a food-safe silicone spray to prevent rusting; if not properly protected; these parts will begin to rust very quickly.

DO NOT use rusted parts.

WARNING! NEVER RUN GRINDER DRY WITHOUT MEAT! It can cause damage to the

FOOD SAFETY

WHEN HANDLING FOOD, THE BASIC RULES TO FOLLOW ARE:

COOK, SEPARATE CLEAN AND CHILL

COOK

It's crucial to cook food to a safe internal temperature to destroy bacteria that is present. The safety of hamburgers and other foods made with ground meat has been receiving a lot of attention lately, and with good reason. When meat is ground, the bacteria present on the surface are mixed throughout the ground mixture. If this ground meat is not cooked to at least 160°F to 165°F (71°C to 74°C), bacteria will not be destroyed and there's a good chance you will get sick. Solid pieces of meat like steaks and chops don't have dangerous bacteria like E. coli on the inside, so they can be served more rare. Still, any beef cut should be cooked to an internal temperature of at least 145°F (63°C) (medium rare). The safe temperature for poultry is 180°F (82°C) and solid cuts of pork should be cooked to 160°F (71°C). Eggs should be thoroughly cooked too. If you are making a meringue or other recipe that uses uncooked eggs, buy specially pasteurized eggs or use prepared meringue powder.

SEPARATE

Occurs when raw meats or eggs come in contact with foods that will be eaten uncooked. This is a major source of food poisoning. Always double-wrap raw meats and place them on the lowest shelf in the refrigerator so there is no way juices can drip onto fresh produce. Then use the raw meats within 1-2 days of purchase, or freeze for longer storage. Defrost frozen meats in the refrigerator, not on the counter. When grilling or cooking raw meats or fish, make sure to place the cooked meat on a clean platter. Don't use the same platter you used to carry the food out to the grill. Wash the utensils used in grilling after the food is turned for the last time on the grill, as well as spatulas and spoons used for stir-frying or turning meat as it cooks. Make sure to wash your hands after handling raw meats or raw eggs. Washing hands with soap and water, or using a pre-moistened antibacterial towelette is absolutely necessary after you have touched raw meat or raw eggs. Not washing hands and surfaces while cooking is a major cause of cross-contamination.

CLEAN

Wash your hands and work surfaces frequently when you are cooking. Washing with soap and warm water for at least 15 seconds, then dry with a paper towel.

CHILL

Chilling food is very important. The danger zone where bacteria multiply is between 40°F and 140°F (4°C and 6°C). Your refrigerator should be set to 40°F (4°C) or below; your freezer should be 0°F (-17°C) or below. Simple rule: serve hot foods hot, cold foods cold. Use chafing dishes or hot plates to keep food hot while serving. Use ice water baths to keep cold foods cold. Never let any food sit at room temperature for more than 2 hours --- 1 hour if the ambient temperature is 90°F (32°C) or above. When packing for a picnic, make sure the foods are already chilled when they go into the insulated hamper. The hamper won't chill food --- it just keeps food cold when properly packed with ice. Hot cooked foods should be placed in shallow containers and immediately refrigerated so they cool rapidly. Make sure to cover foods after they are cool.

NOTE: Special considerations must be made when using venison or other wild game, since it can become heavily contaminated during field dressing. Venison is often held at temperatures that could potentially allow bacteria to grow, such as when it is being transported. Refer to the USDA Meat and Poultry Department for further questions or information on meat and food safety.