

Please read instructions carefully before use. Retain for future reference

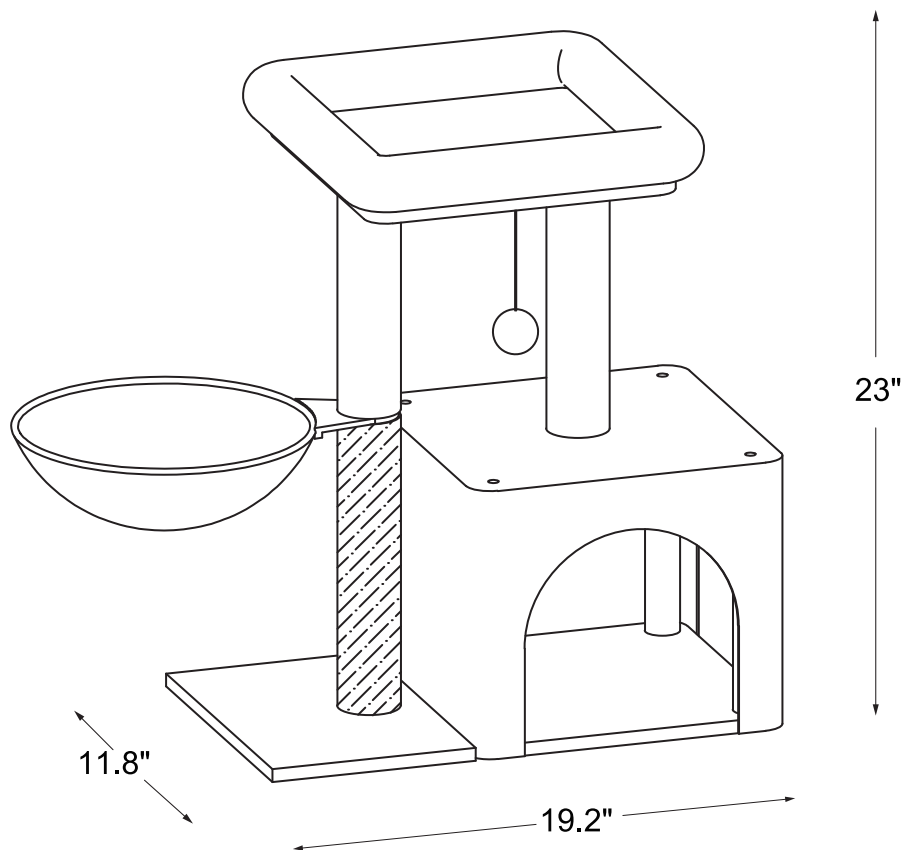

Assembled Dimensions

19.2 IN. W x 11.8 IN. D x 23 IN. H
(48.8 CM W X 30 CM D X 58.4 CM H)

Distributed by:
TRACTOR SUPPLY COMPANY
5401 VIRGINIA WAY,
BRENTWOOD TN 37027
For customer support,
call: 1-888-376-9601
www.TractorSupply.com
MADE IN CAMBODIA

Approximate
assembly time: **8 Minutes**





People
for assembly:



Required assembly space:
39.4in x 39.4in (1m x 1m)

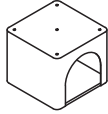
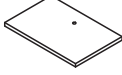
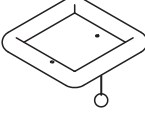

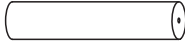
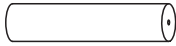
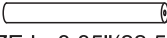
PART LIST

Part	Description	Drawing	Qty.
1	Bottom plush-lined hideout		1PC
2	Base board		1PC
3	Top lying plate		1PC
4	Post	 SIZE L=10.62"(27cm)	1PC
5	Post	 SIZE L=10.03"(25.5cm)	1PC
6	Post	 SIZE L=8.66"(22cm)	1PC
7	Post	 SIZE L=8.85"(22.5cm)	4PCS
8	Cuddle cradle		1PC

HARDWARE LIST

Accessory	Size	Quantity
 A	M8 x 35mm	12PCS
 B	M8 x 80mm	1PC
 C	5mm	1PC

TIP BEFORE YOU START

- * Ensure that all parts are present prior to assembly.
- * Check all packing material carefully before discarding, as some parts may be encased in the packing material.
- * For ease and speed of assembly, it is recommended that prior to each step all required parts are identified.
- * Ensure that you have sufficient space and people (as indicated on page 1) to assemble product safely.
- * During assembly take care not to over-tighten any fittings, as this may damage the product.

CARE AND MAINTENANCE

- * Always inspect the product during each use for any obstructions.
- * The manufacturer will not accept responsibility for unauthorized repairs or modifications to this product.
- * To prolong the life of your cat furniture we recommend storage in a dry area when not in use or during austere weather conditions.

WEIGHT LIMIT

Total Max Weight 48 LBS. (Total Max Weight 21KG)

ASSEMBLY INSTRUCTIONS

Step 1. Connect post 7 to part 1, using screw A

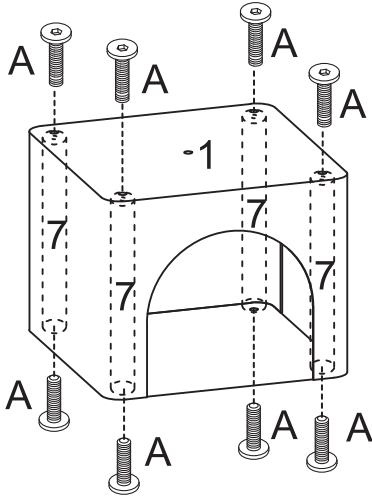

Step 2. Connect post 5 to part 1, using screw A

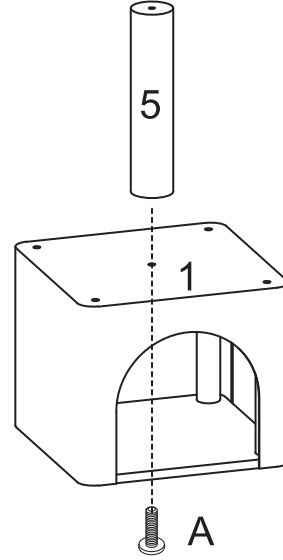

Step 3. Connect post 4 to part 2, using screw A
Connect post 4, part 8 and post 6, using screw B

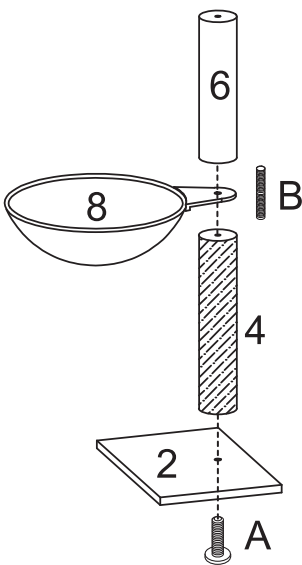

Step 4. Connect part 3 to post 5 and post 6, using screw A

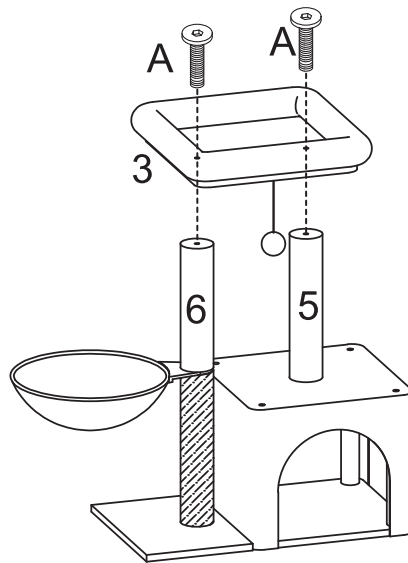

Assembly Finished

