

**RTS**  
*Home*  
**ACCENTS**

## Air Conditioner Cover with Planter - Extra Large (36"W x 36"D x 45"H) Assembly Instructions

**Read all instructions before assembly.**

**WARNING: RTS Home Accents is not responsible for performance of assembled product and will assume no liabilities.**

**Questions? Missing Parts? Call us at 1-888-641-3077 (USA),  
 1-800-663-2803 (Canada) or email us at [wecare@rtscompaniesinc.com](mailto:wecare@rtscompaniesinc.com)**

RTS Home Accents warrants its products to be free from defects in materials and workmanship under normal use and service for the period of one year. The warranty period begins on the date of invoice. The warranty does not cover defects which are merely cosmetic but is limited to defects which result in structural failure, including structural failure due to material corrosion or deterioration. The warranty applies to the original purchaser of the product and is not assignable or transferable. The warranty does not cover damage due to vandalism, abuse, lack of maintenance, or improper installation. RTS standard terms and conditions apply. To begin a warranty claim, call us at 1-888-641-3077 (USA), 1-800-663-2803 (Canada) or email us at [wecare@rtscompaniesinc.com](mailto:wecare@rtscompaniesinc.com).

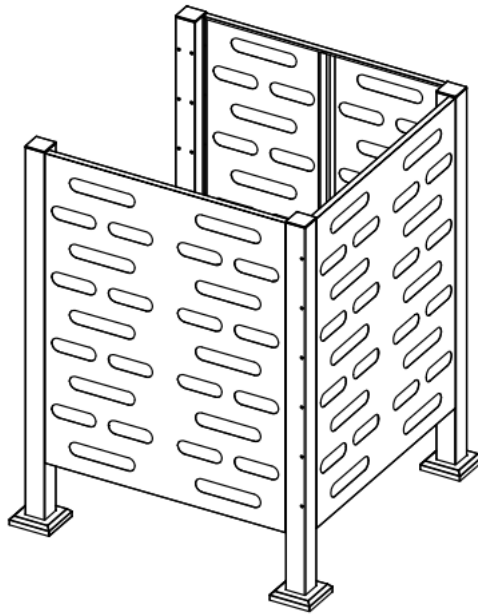

**Air Conditioner Cover with Planter - Extra Large (36"W x 36"D x 45"H)**







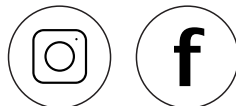

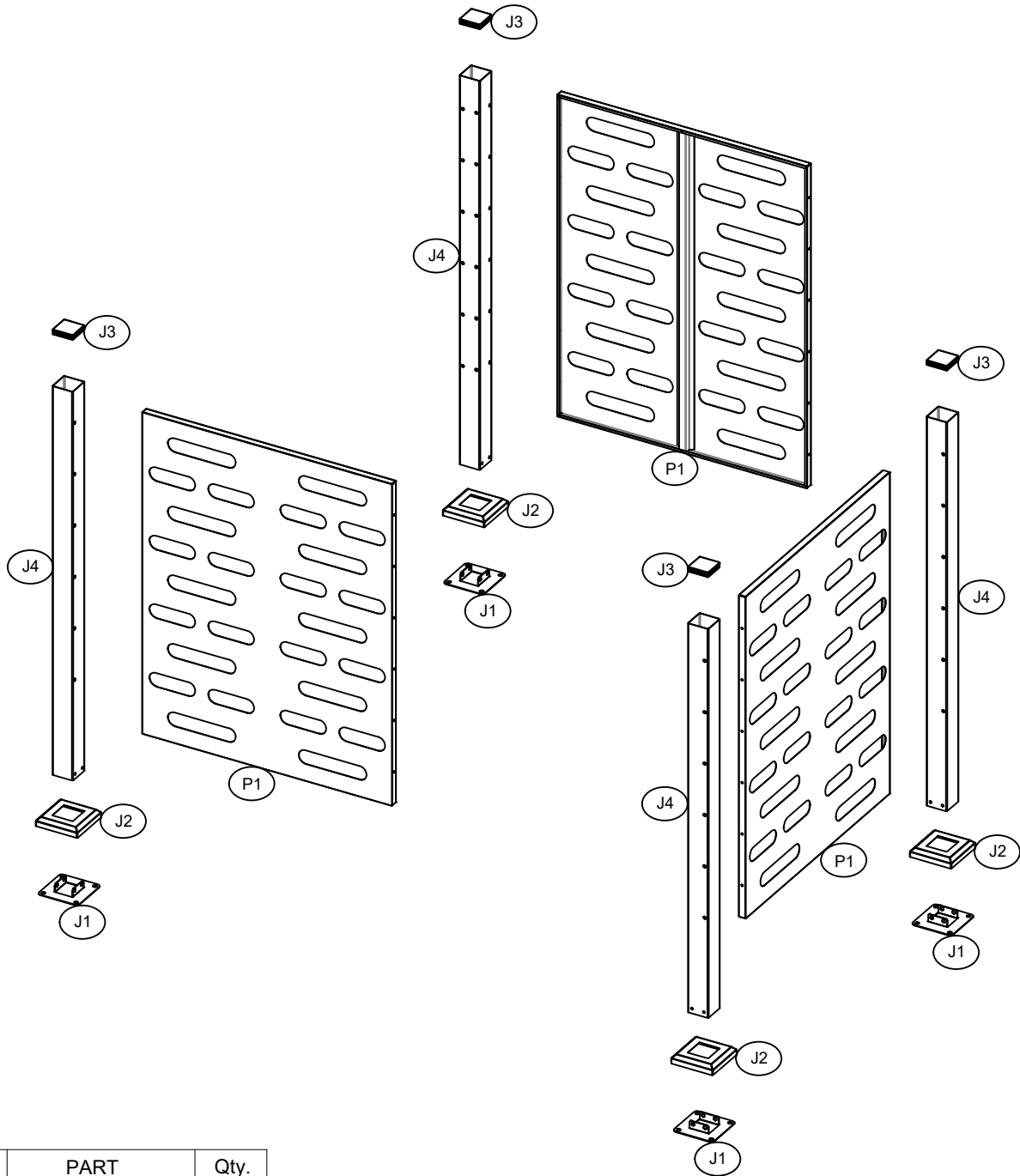
**We hope you are happy with your purchase.**

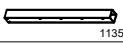

**Please visit the website you purchased from today to leave a review!**

**View more products in the RTS Home Accents family at  
[www.rtshomeaccents.com](http://www.rtshomeaccents.com)**





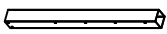

NO.	PART	Qty.
J1		4
J2		4
J3		4
J4	 1135mm	4
P1	 940mm	3
F1		52
A6		16
A7		16
S3		16

NO.	PART	Qty.
J2		4
J3		4
J4		4

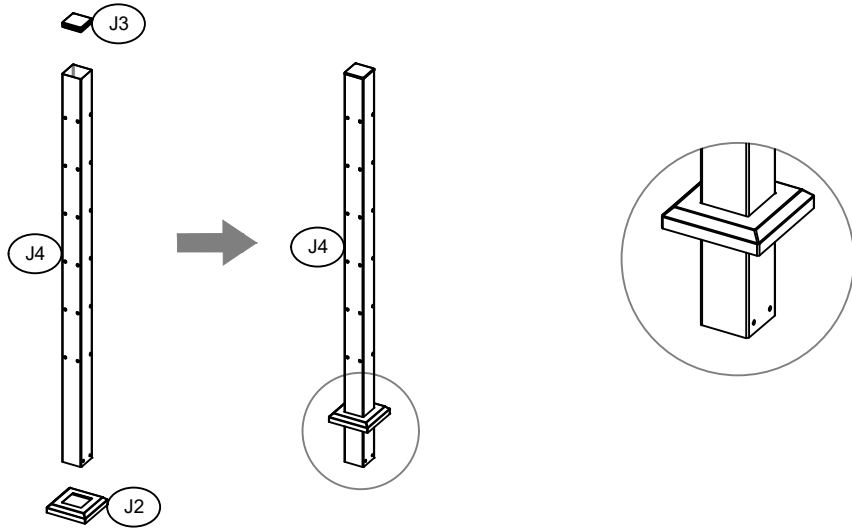
**X4**



NO.	PART	Qty.
J1		4

**X4**

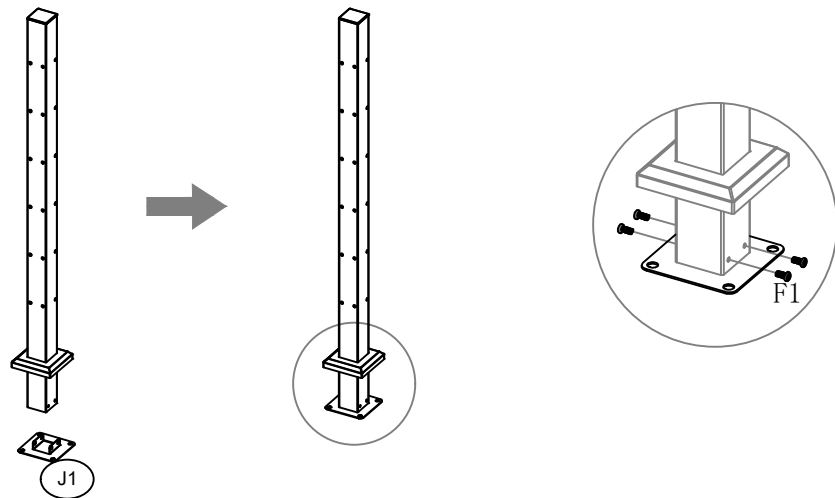

NO.	PART	Qty.
P1		2

**X2**

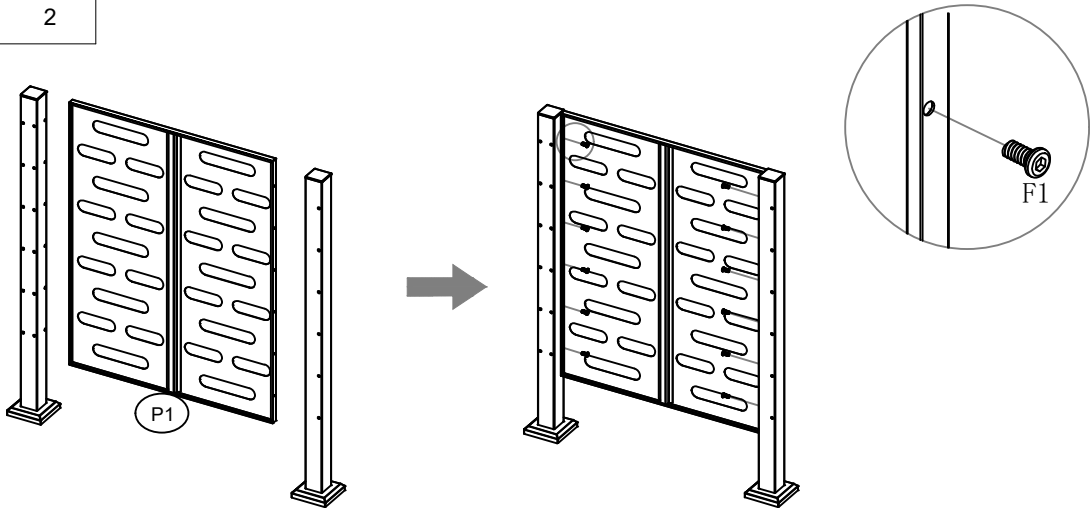

NO.	PART	Qty.
P1		1

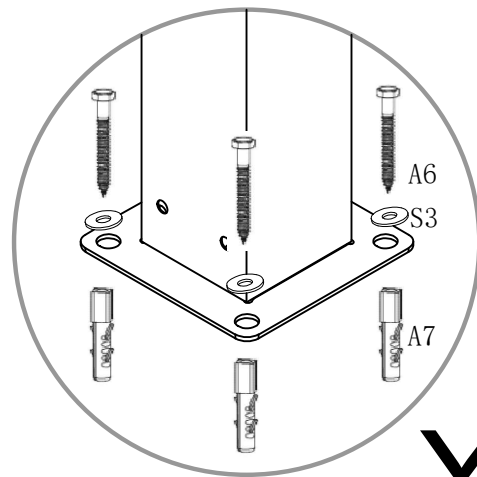
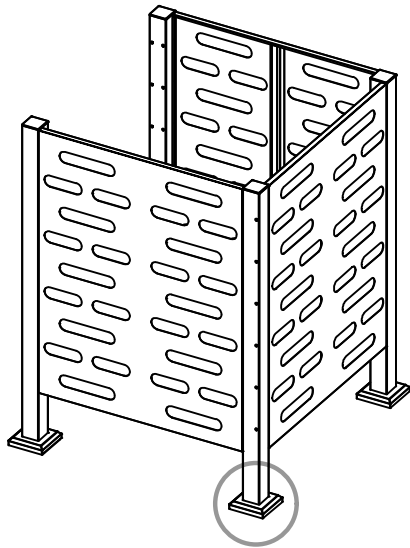
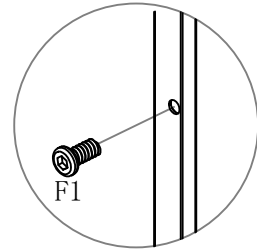
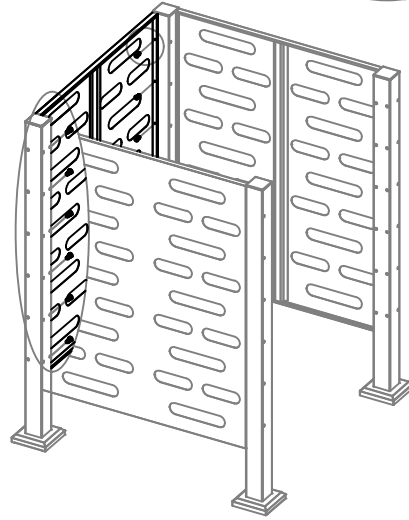
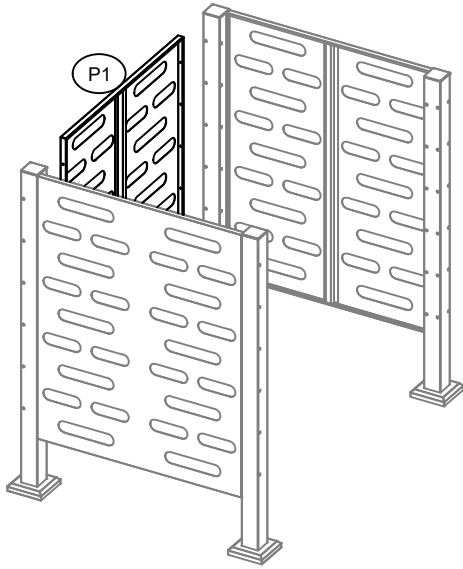

**X4**