



# **GRAVITY FEEDER**

**MODEL GF-80**

# PRODUCT INTRODUCTION

## Tools Required

- Phillips Screwdriver 
- Safety Glasses 

## ⚠ SAFETY INFORMATION ⚠

### FAILURE TO COMPLY WITH THESE WARNINGS COULD RESULT IN SERIOUS PERSONAL INJURIES.

- Properly secure the feeder to a tree or post before inserting food to prevent item from falling.
- Ensure all hardware is firmly tightened before and after mounting feeder.
- Do not pull or hang on the feeder while mounted.
- Do not sit or rest under the feeder while mounted.

## LIST OF PARTS INCLUDED:

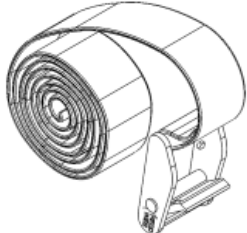
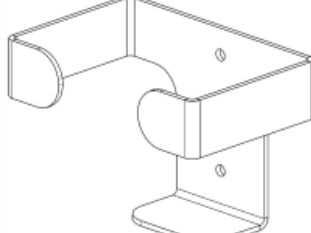
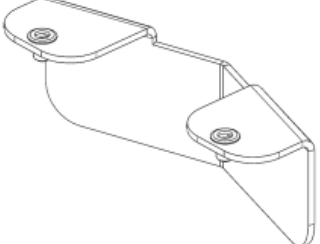
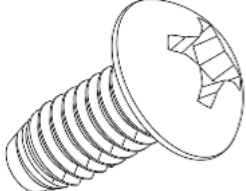
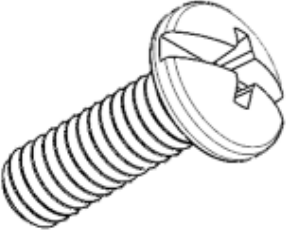
<p><b>A</b></p> <p><b>Adjustable Strap (x2)</b></p>		<p><b>D</b></p> <p><b>Mineral Brick Holder (x1)</b></p>	
<p><b>B</b></p> <p><b>T-Post Mounting Bracket (x2)</b></p>		<p><b>E</b></p> <p><b>Blunt Tip Sheet Metal Screw (x2)</b></p>	
<p><b>C</b></p> <p><b>Pan Head Screw (x4)</b></p>		<p><b>Carefully remove all contents from packaging and verify all parts were received.</b></p>	

## STRAP INSTALLATION

1. The Gravity Feeder comes with mounting brackets already installed to the backside of the feeder along with two adjustable straps (**part A**). The mounting brackets on the back have slots made for these straps to be inserted into.
2. Once it has been determined where the feeder will be mounted, insert the straps through the slots on the back mounting brackets.

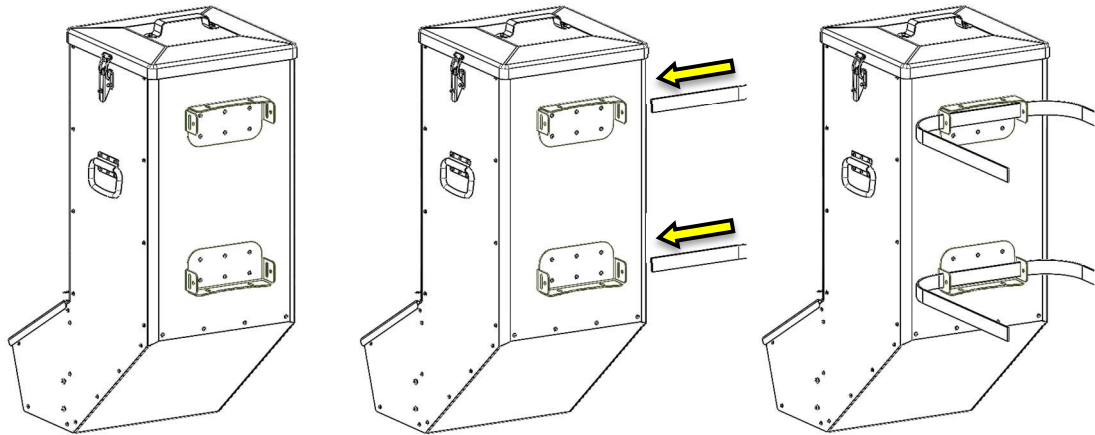

3. Wrap the straps around the tree or post and set it to the desired height. Insert the end of the strap through the buckle and pull it tight. This ensures the mounting brackets are making good contact.

**Note:** Recommended height is 36-42 inches off the ground.

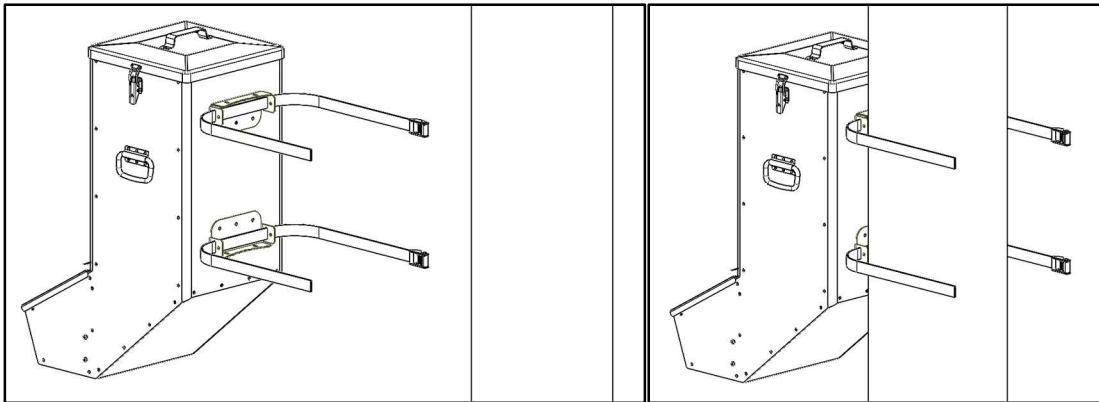

4. Ensure that both straps are pulled tight to stabilize the Gravity Feeder before inserting food.

# T-POST BRACKET INSTALLATION

1. The Gravity Feeder comes with an optional T-Post mounting kit. This includes two T-Post mounting brackets (**part B**) and four pan head screws (**part C**).

**Note:** Having a second person to help will make it easier to install.

2. The brackets are installed with the "Arrow/Pointed" side of the bracket facing away from the feeder. The flat side of the bracket faces up. Loosely install both T-Post brackets using one of the pan head screws. Leave the bracket in an open position.

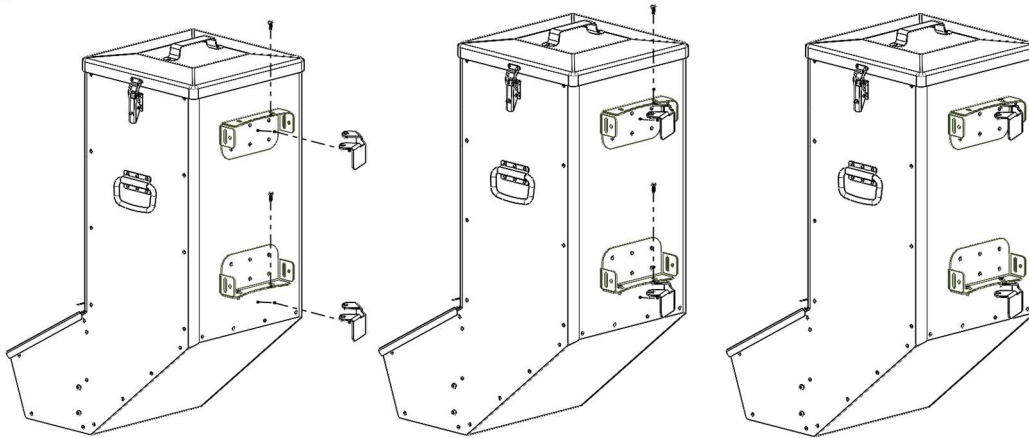

3. Set the Gravity Feeder to the desired height on the T-Post. Once the height has been determined, rest the bracket on the T-Post bump outs.

**Note:** Recommended height is 36-42 inches off the ground.

4. Swing the brackets around the T-Post and clamp down tightly. Now insert the second screw into both T-Post brackets.

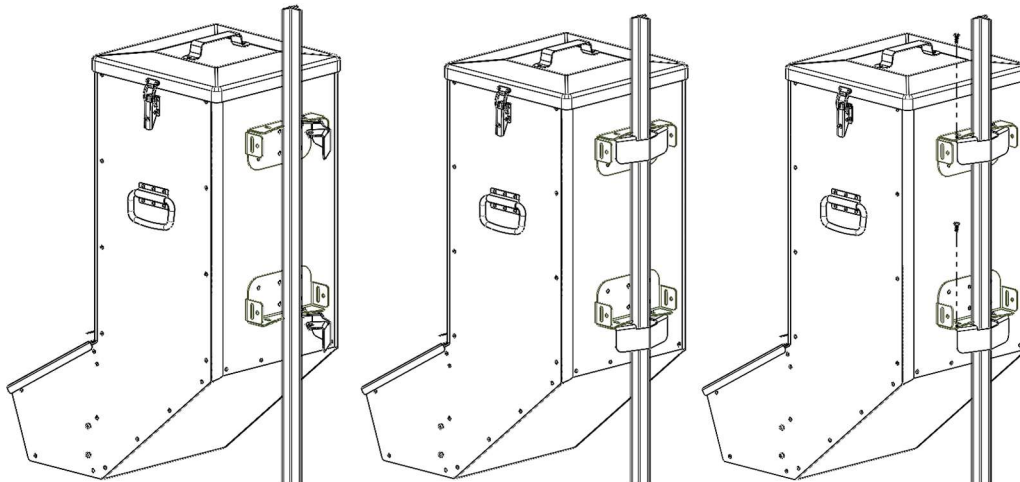

5. Double check both screws by tightening them. Push the T-Post bracket firmly against the post and repeat for both brackets, tightening as needed.

**Pro tip:** Sliding a 2" piece of PVC pipe over the T-Post close to the bottom of feeder will ensure rodents and raccoons can't climb up and eat feed.

# MINERAL BRICK HOLDER INSTALLATION

1. The Gravity Feeder comes with an optional Mineral Brick Holder (**part D**). It includes two extra sheet metal screws (**part E**) used to install the Mineral Brick Holder. The Gravity Feeder comes with sheet metal screws already installed in the locations that the mineral block can be attached so the extra sheet metal screw will not be needed.
2. There are two spots where the Mineral Brick Holder can be mounted. They are located on either side of the Gravity Feeder.

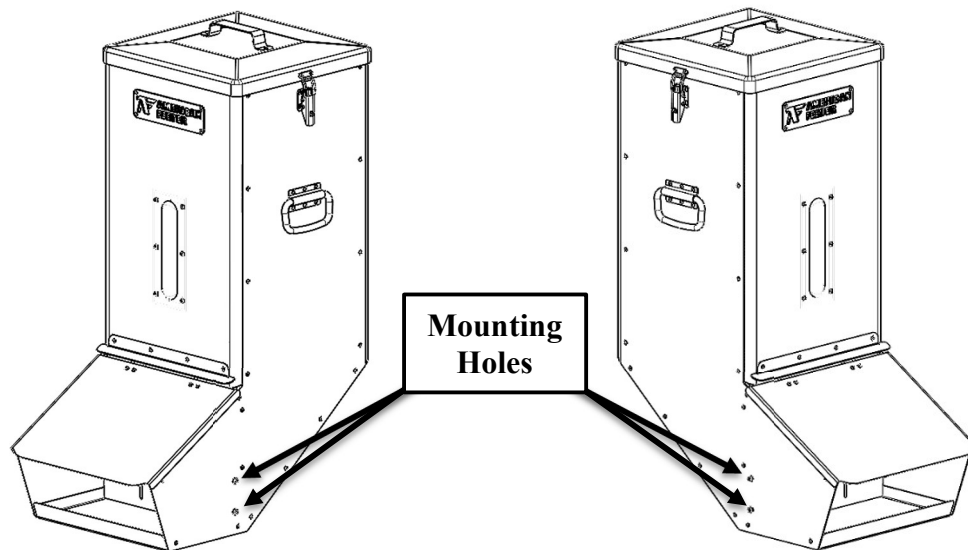

3. Once a side has been determined, remove the screws and line up the Mineral Brick Holder's holes with the two now available mounting holes.
4. Insert each screw into the holes and hand tighten the screws with a screwdriver, attaching the Mineral Brick Holder to the body of the feeder. The screw heads should sit flush on the bracket.

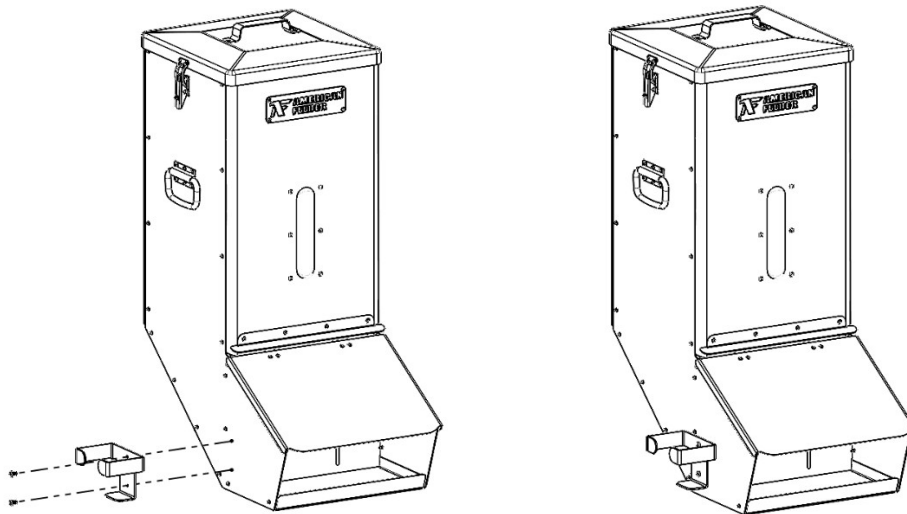

## **ADDITIONAL INFORMATION:**

### **LATCH FUNCTIONALITY**

1. The Gravity Feeder has two latches used to clamp down the lid. These latches include a safety catch that prevents the latch from opening unexpectedly.
2. When opening the latch, first press and hold down on the safety catch to prevent it from stopping the lever.
3. While the safety is pressed down, pull up on the lever to successfully open the latch.

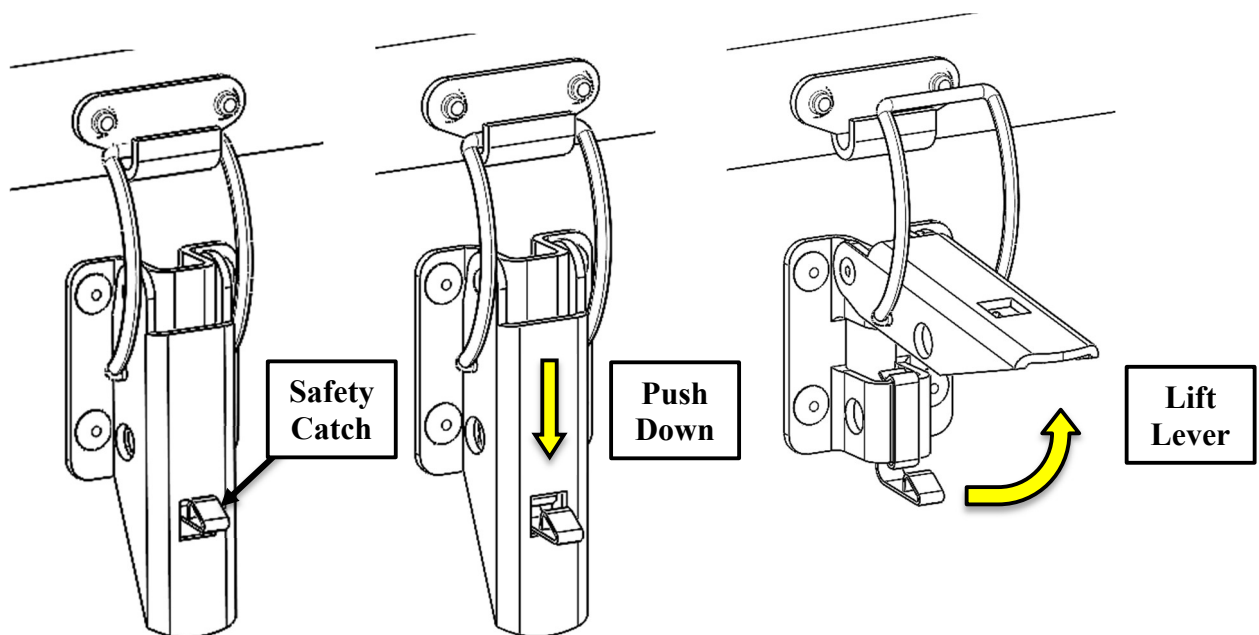

## ADJUSTABLE PANEL FUNCTIONALITY

1. The Gravity Feeder includes an adjustable panel used to control the amount of food available to eat at a time.
2. Before loading the food into the Gravity Feeder, make sure that the adjustable panel is lowered all the way down. This will prevent food from shooting out of the bottom when loading the food. Loosen the wing-bolts till the adjustable panel can move, then lower it to its lowest point. Tighten the wing-bolts once the panel is set.

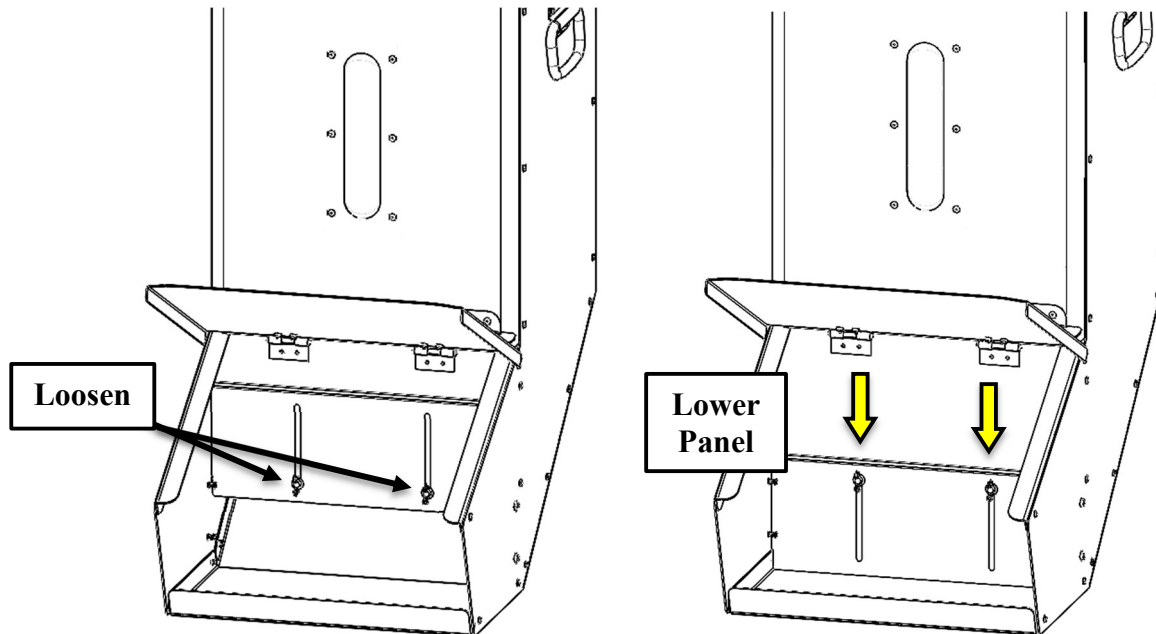

3. Once the food is loaded, loosen the wing-bolts and set the desired height of the adjustable panel. Tighten the wing-bolts when the desired level is set.

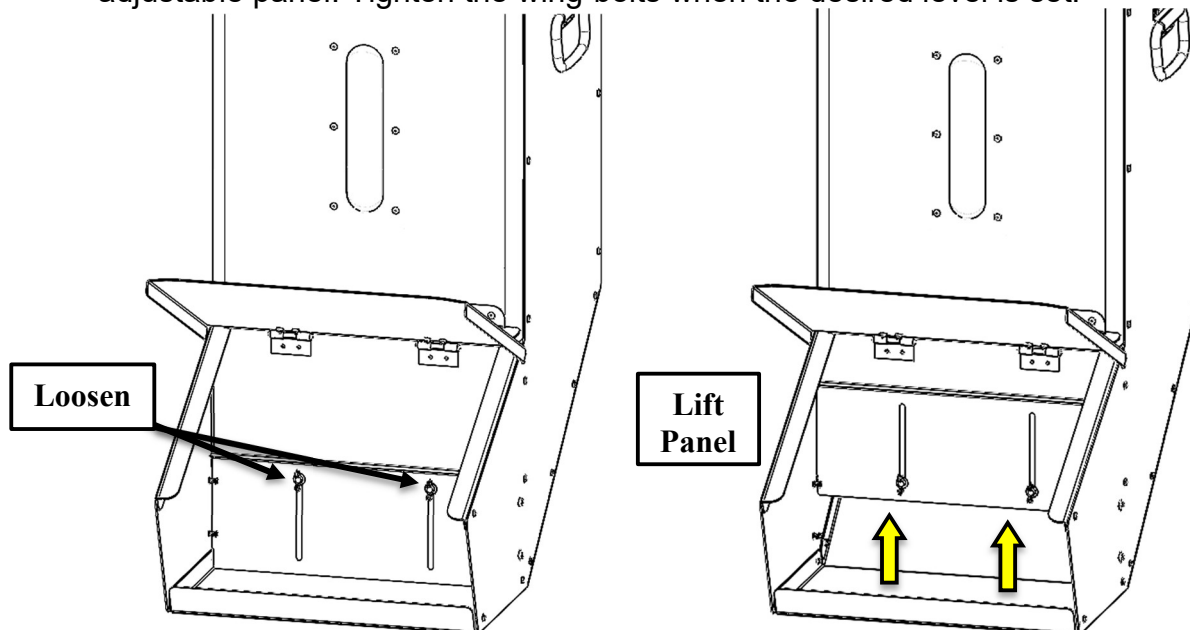

# Contact Info

## AMERICAN FEEDERS, INC.

1-901-474-7110

info@american-feeders.com

<https://american-feeder.com/>

### Thank you for your purchase!

Thank you for choosing American Feeder. We appreciate your trust in our brand and are delighted that you've decided to make our product a part of your life. This user manual has been carefully crafted to help you get the most out of your purchase, ensuring that you have a seamless and satisfying experience with your new feeder. Please follow the instructions carefully to discover the features, tips, and insights that will empower you to make the most of your Gravity Feeder.

#### One-Year Limited Warranty

**Warranty Coverage:** American Feeder warrants that the product is free from defects in material and workmanship under normal use for a period of one (1) year from the date of purchase by the original consumer ("the Warranty Period"). This limited warranty is applicable only to the original purchaser of the product and is non-transferable.

**Warranty Claims:** During the Warranty Period, if the product is found to be defective due to material or workmanship issues, the Company will, at its discretion, either repair or replace the product or component free of charge. The Company reserves the right to use new, refurbished, or reconditioned parts or products in the warranty service process. Warranty does not cover paint wearing off due to animals.

**Exclusions and Limitations:** This one-year limited warranty does not cover:

1. Damage resulting from accident, misuse, abuse, neglect, unauthorized modification, or any other actions inconsistent with the intended use of the product.
2. Normal wear and tear, cosmetic damage, or changes in product color or texture.
3. Damage resulting from exposure to extreme temperatures, humidity, or other environmental factors.
4. Damage due to third-party accessories or modifications not authorized by the Company.
5. Consumable parts, such as batteries, unless they are found to be defective upon arrival.
6. Products purchased from unauthorized dealers or sources.

**Obtaining Warranty Service:** To obtain warranty service, the original consumer must:

1. Contact our customer service team at [Customer Service Contact Information] to initiate a warranty claim.
2. Provide proof of purchase, including the purchase date and the original purchase receipt.
3. Follow the instructions provided by our customer service team for returning the product.

**Disclaimer:** The warranty described above is the sole and exclusive warranty provided by the Company and supersedes any other warranties, whether express or implied, including any warranties of merchantability or fitness for a particular purpose. The Company shall not be liable for any incidental or consequential damages arising from the use or inability to use this product.

**State Law Rights:** This warranty gives you specific legal rights, and you may also have other rights that vary from state to state. Some states do not allow limitations on implied warranties or the exclusion or limitation of incidental or consequential damages, so the above limitations may not apply to you.

**Baiting Laws:** Please check your local state laws prior to setting up your feeder for baiting.

**Contact Information:** For warranty claims or inquiries, please contact our customer service team at (901) 474-7110.